

# Appendix J: Full Health Economics Report

## 1.3 Contents

4	<b>Appendix J: Full Health Economics Report</b> .....	1
5	1.1 Contents .....	1
6	1.2 Introduction .....	2
7	1.3 Decision Problem .....	2
8	1.4 Systematic Review of Existing Literature .....	5
9	<b>2 Gallstones Health Economic Model</b> .....	<b>8</b>
10	2.1 Model Structure .....	8
11	2.2 Model States .....	9
12	2.3 Model Transitions .....	12
13	2.3.1 Laparoscopic cholecystectomy with intraoperative cholangiography	
14	versus laparoscopic cholecystectomy (Q4b.1) .....	13
15	2.3.2 Laparoscopic cholecystectomy versus conservative management	
16	(Q4b.2) .....	15
17	2.3.3 Day-case versus inpatient laparoscopic cholecystectomy (Q4b.3) .....	17
18	2.3.4 Laparoscopic cholecystectomy with bile duct exploration versus	
19	laparoscopic cholecystectomy with pre-, intra- or postoperative ERCP	
20	(Q4c.1) .....	18
21	2.3.5 ERCP and laparoscopic cholecystectomy versus ERCP alone (Q4c.2) .....	21
22	2.3.6 ERCP versus conservative management (Q4c.3) .....	23
23	2.3.7 Early versus delayed laparoscopic cholecystectomy (Q5a.1) .....	25
24	2.3.8 Early versus delayed laparoscopic cholecystectomy following ERCP	
25	(Q5a.2) .....	27
26	2.4 Model Parameters .....	29
27	2.4.1 Initial patient distributions .....	29
28	2.4.2 Probabilities of having or developing symptoms .....	29
29	2.4.3 Baseline event probabilities .....	29
30	2.4.4 Probabilities of operative consequences .....	30
31	2.4.5 Costs and Resource Use .....	32
32	2.4.6 Utility Values .....	34
33	2.5 Model Assumptions .....	37
34	2.6 Sensitivity Analyses .....	38
35	<b>3 Results and Conclusions</b> .....	<b>48</b>
36	3.1 Cost effectiveness results for Review Question 4b: managing symptomatic	
37	gallbladder stones .....	48
38	3.1.1 Laparoscopic cholecystectomy with intraoperative cholangiography	
39	versus laparoscopic cholecystectomy alone (Q4b.1) .....	48

1	3.1.2	Laparoscopic cholecystectomy versus conservative management (Q4b.2).....	51
2			
3	3.1.3	Day-case versus inpatient laparoscopic cholecystectomy (Q4b.3) .....	54
4	3.2	Cost effectiveness results for Review Question 4c: managing common bile duct stones .....	57
5			
6	3.2.1	Laparoscopic cholecystectomy with bile duct exploration versus laparoscopic cholecystectomy with pre-, intra- or postoperative ERCP (Q4c.1).....	57
7			
8			
9	3.2.2	ERCP and laparoscopic cholecystectomy versus ERCP alone (Q4c.2).....	59
10	3.2.3	ERCP versus conservative management (Q4c.3) .....	62
11	3.3	Cost effectiveness results for Review Question 5: timing of laparoscopic cholecystectomy .....	65
12			
13	3.3.1	Early versus delayed laparoscopic cholecystectomy (Q5a.1) .....	65
14	3.3.2	Early versus delayed laparoscopic cholecystectomy following ERCP (Q5a.2).....	68
15			
16	3.4	Discussion .....	71
17	3.4.1	Principal findings.....	71
18	3.4.2	Model strengths .....	71
19	3.4.3	Model limitations .....	71
20	3.4.4	Comparison with other health economic analyses .....	72
21	3.5	Conclusions .....	73
22			

## 1.2 Introduction

24 This appendix sets out the de novo health economic evaluation undertaken to assess the  
 25 cost effectiveness of interventions and their timing for the treatment of symptomatic  
 26 gallbladder stones and common bile duct stones. It was developed by the Internal Clinical  
 27 Guidelines Programme at NICE.

## 1.3 Decision Problem

29 The health economic analysis addressed three questions from the guideline scope, based on  
 30 the GDG's question prioritisation:

31 **Table 1: Guideline Questions Addressed by Health Economic Analysis**

Question Number	Question
4b	Which strategies should be used for managing symptomatic gallbladder stones?
4c	Which strategies should be used for managing common bile duct stones (CBDS)?
5	In adults with acute cholecystitis or symptomatic common bile duct stones, should cholecystectomy be performed during the acute episode (early) or should intervention be delayed until the acute episode has subsided (delayed)?

32 A number of interventions were indicated for these questions, primarily based around  
 33 different presentations of laparoscopic cholecystectomy and to endoscopic retrograde  
 34 cholangiopancreatography (ERCP). However, the GDG indicated that, as the interventions  
 35 address different populations, pairwise rather than multiple comparisons should be  
 36 undertaken in most cases. Only one multiple comparison was indicated, for question 4c.

- 1 Table 2 lists the PICO for each comparison and in each case, the comparator is taken to
- 2 reflect usual care.
  
- 3 The GDG chose not to model the biliary stents comparison due to a lack of clinical interest in
- 4 the health economic outcomes and a lack of clinical evidence. The percutaneous
- 5 cholecystostomy and day-case versus inpatient ERCP comparisons were also not modelled,
- 6 as no clinical studies were included for these comparisons.
- 7

**Table 2: Population, Intervention, Comparison and Outcome for Included Guideline Questions**

Sub Question	Population	Intervention	Comparator	Outcome
4b.1	Patients undergoing laparoscopic cholecystectomy with a suspicion of CBDS	Laparoscopic cholecystectomy with intraoperative cholangiography (IOC)	Laparoscopic cholecystectomy	In order to perform a cost–utility analysis, quality adjusted life years (QALYs) were used
4b.2	Patients with symptomatic gallbladder stones	Laparoscopic cholecystectomy	Conservative management	
4b.3	Patients with symptomatic gallbladder stones	Day-case laparoscopic cholecystectomy	Inpatient laparoscopic cholecystectomy	
4c.1	Patients who are suspected of symptomatic CBDS	Laparoscopic cholecystectomy with intraoperative bile duct exploration	Laparoscopic cholecystectomy with preoperative ERCP	
		Laparoscopic cholecystectomy with intraoperative ERCP		
		Laparoscopic cholecystectomy with postoperative ERCP		
4c.2	Patients who have had their symptomatic CBDS treated by ERCP	Routine laparoscopic cholecystectomy	Laparoscopic cholecystectomy as required	
4c.3	Patients who are suspected of symptomatic CBDS	ERCP	Conservative management	
5a.1	Patients with symptomatic gallbladder stones	Early laparoscopic cholecystectomy (within 1 week)	Delayed laparoscopic cholecystectomy (6-8 weeks delay)	
5a.2	Patients with symptomatic gallbladder stones who have had their CBDS treated by ERCP	Early laparoscopic cholecystectomy following ERCP (within 1 week)	Delayed laparoscopic cholecystectomy following ERCP (6-8 weeks delay)	

## 1.4 Systematic Review of Existing Literature

2 One literature search was undertaken to address all comparisons in questions 4 and 5. The  
3 search was based on the clinical search with a health economic filter applied and yielded  
4 1,396 unique citations (see appendix D for the search strategy). A number of cost–utility  
5 analyses (CUAs) were found, but only two were included that covered the populations and  
6 interventions of interest (Gurusamy et al. 2012), (Wilson et al. 2010).

7 Wilson et al. (2010) (see Table 3) used a decision tree to compare early and delayed  
8 laparoscopic cholecystectomy for acute cholecystitis (question 5a.1 in Table 2). Wilson et al.  
9 (2010) modelled the development of four symptoms (biliary colic, acute cholecystitis,  
10 obstructive jaundice and pancreatitis) at 9 weeks during an 18 week delay period, with a time  
11 horizon of one year. Laparoscopic cholecystectomy could result in conversion to open  
12 cholecystectomy and either could incur bile duct injury, bile leak, other or no complications.  
13 Costs were based on NHS reference costs and utilities were taken from a small non-UK,  
14 non-patient-based time trade-off study.

15 Whilst Wilson et al. (2010) was directly relevant to the UK NHS and to the guideline question,  
16 it had a number of limitations. The GDG felt that the delay of 18 weeks in the delayed  
17 surgery arm was too long and preferred to consider (from both a practical and evidential  
18 perspective) a 6–8 week delay. The model structure gave no consideration to the potential  
19 existence, recurrence or complications of common bile duct stones (CBDS) and to do so  
20 would require a longer time horizon than one year. Also, the model did not consider operative  
21 or background mortality. Finally the utility data did not meet the NICE reference case  
22 preference (National Institute for Health and Care Excellence 2013) for EQ-5D surveyed from  
23 patients with the disease in question and scored by the UK general public.

24 Gurusamy et al. (2012) (see Table 4) used a very similar decision tree to Wilson et al. (2010)  
25 to compare intraoperative and preoperative ERCP for patients with gallbladder stones and  
26 CBDS (question 4c.3 in Table 2). Gurusamy et al. (2012) modelled the successful or failed  
27 (and subsequent repeat ERCP) CBDS extraction, 6 complications of ERCP (perforation,  
28 pancreatitis, cholangitis, cholecystitis, bleeding and gastric ulcer), consequent  
29 cholecystectomy (laparoscopic or open) and mortality from symptoms and open operations.  
30 Costs were based on NHS references costs and utilities were taken from a small, non-UK,  
31 non-patient-based time trade-off study or based on assumptions.

32 Whilst Gurusamy et al. (2012) was directly relevant to the UK NHS, by excluding  
33 postoperative ERCP and intraoperative bile duct exploration, the model did not compare all  
34 the interventions included in this guideline question.

35 A third RCT-based CUA was found that was included in the clinical evidence review  
36 (Macafee et al. 2009). However, it was excluded from the health economic analysis due to  
37 serious concerns about its QALY calculations.

38 As no published CUAs were found that covered all included interventions, an original health  
39 economic model was constructed. The GDG felt a de novo model would better consider  
40 operative and background mortality, the long term quality of life impact of bile duct injuries,  
41 potential symptom and CBDS recurrence and the timing of multiple interventions than the  
42 existing CUAs.

43

**Table 3: Health Economic Evidence – Early versus Delayed Laparoscopic Cholecystectomy For Acute Cholecystitis**

Study, Population, Country and Quality	Data Sources	Other Comments	Incremental			Conclusion	Uncertainty
			Cost	Effect	ICER		
<b>Wilson et al. (2010)</b> Acute cholecystitis UK	<b>Effects:</b> authors' own systematic review, other sources, some assumptions. Rare events modelled using non-informative priors <b>Costs:</b> reference costs £UK, 2006. Adjustments made for longer early LC operations and for increased delayed LC length of stay <b>Utilities:</b> small time trade-off study, not from patients or UK, some assumptions	Decision tree (1 year horizon) 18 week delay period; symptoms develop after 9 weeks LC all done as inpatients Discounting not applied due to short time horizon	-£820	0.05 QALYs	Early LC dominates delayed LC	Early LC is less expensive and results in better QoL than delayed LC	ICER sensitive to extreme values of surgical complications that would not be seen in clinical practice Differences driven by symptoms in delay and extra delayed LC length of stay Quality of life estimates are most uncertain part of model In PSA, early LC has 71% chance of being cost effective at £20,000/QALY

- a Utilities not from patients and not scored by UK general public
- b No consideration of common bile duct stones
- c Time horizon may be limited
- d Some assumptions made in all data sources
- e Decision tree does not allow recurrence of symptoms or common bile duct stones
- f Delay period longer than found in most clinical papers
- g Development of symptoms occurs later than advised by Guideline Development Group
- h No consideration of operative or background mortality

Abbreviations  
 ICER: Incremental cost effectiveness ratio  
 LC: Laparoscopic cholecystectomy  
 PSA: Probabilistic Sensitivity Analysis  
 QALY: Quality adjusted life years  
 UK: United Kingdom

**Table 4: Health Economic Evidence – Intra-Operative Versus Pre-Operative ERCP for CBDS**

Study, Population, Country and Quality	Data Sources	Other Comments	Incremental			Conclusion	Uncertainty
			Cost	Effect	ICER		
<b>Gurusamy et al. (2012)</b> Patients with gallbladder and CBD stones suitable for LC UK  Directly Applicable <sup>a</sup>  Potentially Serious Limitations <sup>b,c,d,e,f</sup>	<b>Effects:</b> authors' own systematic review, other sources, some assumptions. Rare events modelled using non-informative priors  <b>Costs:</b> reference costs £UK, 2008. Some assumptions  <b>Utilities:</b> small non UK time trade-off and standard gamble studies, not from patients, some assumptions	Decision tree (3 year horizon) Preoperative ERCP and LC done in separate hospital admissions  Discounting applied to both costs and QALYs at 3.5%	-£623	0.008	Intraoperative ERCP dominates preoperative ERCP	Intraoperative ERCP is less expensive and resulted in better QALYs than preoperative ERCP	ICER sensitive to extreme values of operative success that would not be seen in clinical practice Complications and conversion rates Cost savings predicated on necessary resource scheduling In PSA, intraoperative ERCP has 93% chance of being cost effective at £20,000/QALY

- a Utilities not from patients and not scored by UK general public
- b Time horizon may be limited
- c Some assumptions made in all data sources
- d Decision tree does not allow recurrence of symptoms
- e Delay between ERCP and LC not specified
- f No consideration of ERCP or laparoscopic cholecystectomy mortality, or background mortality

Abbreviations  
 CBDS: Common bile duct stones  
 ERCP: Endoscopic retrograde cholangiopancreatography  
 ICER: Incremental cost effectiveness ratio  
 LC: Laparoscopic Cholecystectomy  
 PSA: Probabilistic Sensitivity Analysis  
 QALY: Quality adjusted life years  
 UK: United Kingdom

## 2 Gallstones Health Economic Model

2 The model was implemented in Microsoft Excel 2010. In line with the NICE reference case  
3 (National Institute for Health and Care Excellence 2013), an NHS and PSS perspective was  
4 adopted. Costs and benefits were discounted at 3.5% per annum each and all costs were  
5 based on 2011–12 financial year.

### 2.1 Model Structure

7 A single Markov model structure was used to assess all the comparisons listed in Table 2.  
8 The GDG believed it was important, particularly for those comparisons including conservative  
9 management options, to be able to model the recurrence of symptoms and of CBDS. A  
10 Markov model was also able to more accurately capture any differences in mortality. This  
11 was also a reason to adopt a lifetime horizon. The GDG also felt strongly that bile duct  
12 injuries incur lifelong quality of life detriments that needed to be captured within the model.

13 A 2-week cycle length was employed in the Markov model. The GDG felt this represented an  
14 appropriate trade-off between operative length and postoperative recovery that allowed the  
15 model to adequately represent the disease without a proliferation of short-term health states.  
16 Due to the short cycle length, half-cycle correction was not applied within the model.

17 The gallstones model is a natural history model. Transitions between states are not  
18 necessarily by events occurring, but by changes (such as the development of symptoms) in  
19 the health of a patient. The model “knows” the status of a patient, even if the healthcare  
20 professionals or the patient do not. So, for instance, the model knows whether a patient has  
21 CBDS, whether or not the healthcare professional or the patient know the patient has CBDS.

22 The model consists of states that are groupings of options in 3 dimensions (see Figure 1).  
23 The experience of simulated patients always represents the combination of 1 option from  
24 each dimension.

25 In Figure 1, the blue boxes represent the underlying gallstone disease of a patient – they can  
26 be in 1 and only 1 of these states: gallbladder stones, CBDS, both or neither. Note that this is  
27 not the same as diagnosis, as the patient and/or healthcare professional may not know they  
28 have these stones.

29 The yellow ellipses represent things that can happen to a patient within the model. These  
30 include being asymptomatic or symptomatic or receiving an interventional procedure. The  
31 two procedures considered by the model are ERCP (for CBDS) and laparoscopic  
32 cholecystectomy (for gallbladder stones) – both have associated mortality risks. The  
33 “LC+ERCP” option allows for both surgeries to be undertaken in the same 2-week cycle.

34 The GDG gave guidance on what symptoms should be modelled (see Table 5). Symptoms  
35 are specific to the condition; however, a patient whose underlying status is “gallstones and  
36 CBDS” can have any of the 6 symptoms. The model treats each symptom as a mutually  
37 exclusive option, so patients can only have only 1 symptom at any time. The pancreatitis  
38 symptom option has an associated mortality risk.

39 The green lozenges represent the potential long-term consequences of gallstone surgery.  
40 The GDG stated that both laparoscopic and open cholecystectomy can cause bile duct injury  
41 and bile duct injuries have long-term impacts on quality of life.

42 There are 2 additional states that exist outside this framework: gallbladder cancer and death.  
43 These are homogeneous states in which it is not necessary to consider the underlying  
44 gallstone disease state or gallstone symptoms. Surgical, symptom-related and background  
45 mortality are considered.”



1 The scope of this guideline explicitly excludes the diagnosis and treatment of gallbladder  
 2 cancer. However, the development of cancer is a possible consequence of decisions  
 3 regarding the treatment of gallstone disease, especially where conservative, gallbladder in  
 4 situ management approaches are concerned. Therefore, in view of its poor survival and  
 5 impact on quality of life, it was felt gallbladder cancer should be considered as a possible  
 6 outcome in the model for patients in conservative management arms who still have their  
 7 gallbladder.

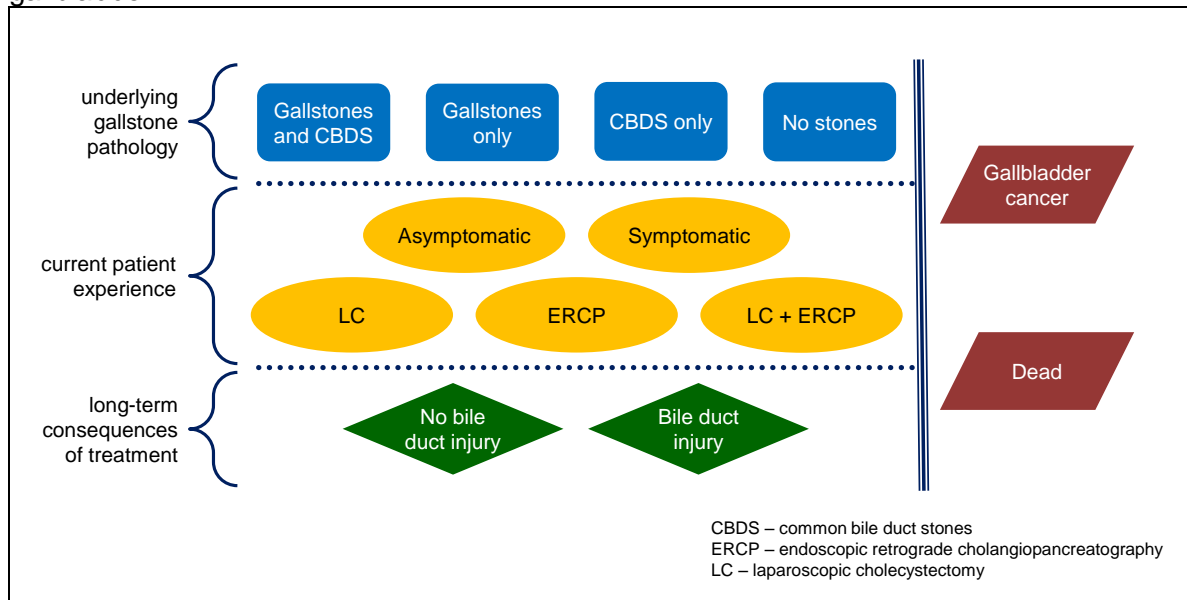

8 **Figure 1: Dimensions of Gallstones Markov Model**

10 **Table 5: Symptoms Included in the Gallstones Model**

Condition	Symptom	First intervention
Gallbladder Stones	Biliary colic	Laparoscopic cholecystectomy
	Acute cholecystitis	
Common Bile Duct Stones	Cholangitis	ERCP
	Jaundice	
	Pancreatitis	
	Sepsis	

## 2.2 Model States

12 Model states are created by combining one of each of the blue, yellow and green  
 13 dimensions. For instance, a patient could have gallstones only, be symptomatic with biliary  
 14 colic and have no bile duct injury. Not all combinations of dimensions are available and not  
 15 all states are relevant to each comparison. Table 6 indicates which options can be combined  
 16 to produce a model state – there are up to 32 states available in the model:

- 17 • Patients in the “gallstones+CBDS” dimension could be in any of the yellow dimensions,  
 18 but only in the “no bile duct injury” dimension
- 19 • Patients in the “gallstones only” option can only be in the “biliary colic” or “acute  
 20 cholecystitis” symptom dimensions or the “asymptomatic” dimension. They could be in  
 21 any of the three intervention dimensions (“ERCP”, “laparoscopic cholecystectomy” or  
 22 “LC+ERCP”)
- 23 • Patients can only be in the “CBDS only” dimension following either of the laparoscopic  
 24 cholecystectomy dimensions (that is, they no longer have their gallbladder)

- 1 • Patients in the “CBDS only” option can be in 1 of the 4 symptom dimensions listed in  
2 Table 5, the “asymptomatic” dimension or the “ERCP” dimension. These patients may or  
3 may not have previously incurred a bile duct injury during their laparoscopic  
4 cholecystectomy
- 5 • Successfully treated patients who are in the “no stones or GB” dimension can only be in  
6 the “asymptomatic” dimension, with or without bile duct injury
- 7 • The gallbladder cancer state can only be entered by those in conservative management  
8 arms (comparator arms of questions 4b.2 and 4c.2, Table 2) who have not yet had a  
9 laparoscopic cholecystectomy (that is, it is only considered as a possible outcome for  
10 people with an extended period with gallbladder in situ)

11

**Table 6: Gallstones Model States - Combinations of Elements That Exist Within the Model**

Long-term consequences	Underlying pathology	Asymptomatic	Symptomatic						LC	ERCP	LC +ERCP
			Biliary Colic	Acute Cholecystitis	Cholangitis	Jaundice	Pancreatitis	Sepsis			
No bile duct injury	GS+CBDS	X	X	X	X	X	X	X	X	X	
No bile duct injury	GS	X	X	X					X	X	
No bile duct injury	CBDS	X			X	X	X	X		X	
No bile duct injury	No stones	X									
Bile duct injury	GS+CBDS										
Bile duct injury	GS										
Bile duct injury	CBDS	X			X	X	X	X		X	
Bile duct injury	No stones	X									
Dead						X					
Gall bladder Cancer						X					

## 2.3 Model Transitions

- 2 The transitions available between states within the model vary between questions and are described below. Even where available transitions are listed as being the same, transition probabilities may differ due to question-specific input data (see section 2.4).
- 3
- 4
- 5 The complete range of possible states and transitions available within the model is illustrated in Figure 2. As each question relates to a particular population and set of treatment options, none of the questions includes every state and transition available in the full model. The subset of options included in each model is detailed and depicted below.
- 6
- 7
- 8
- 9

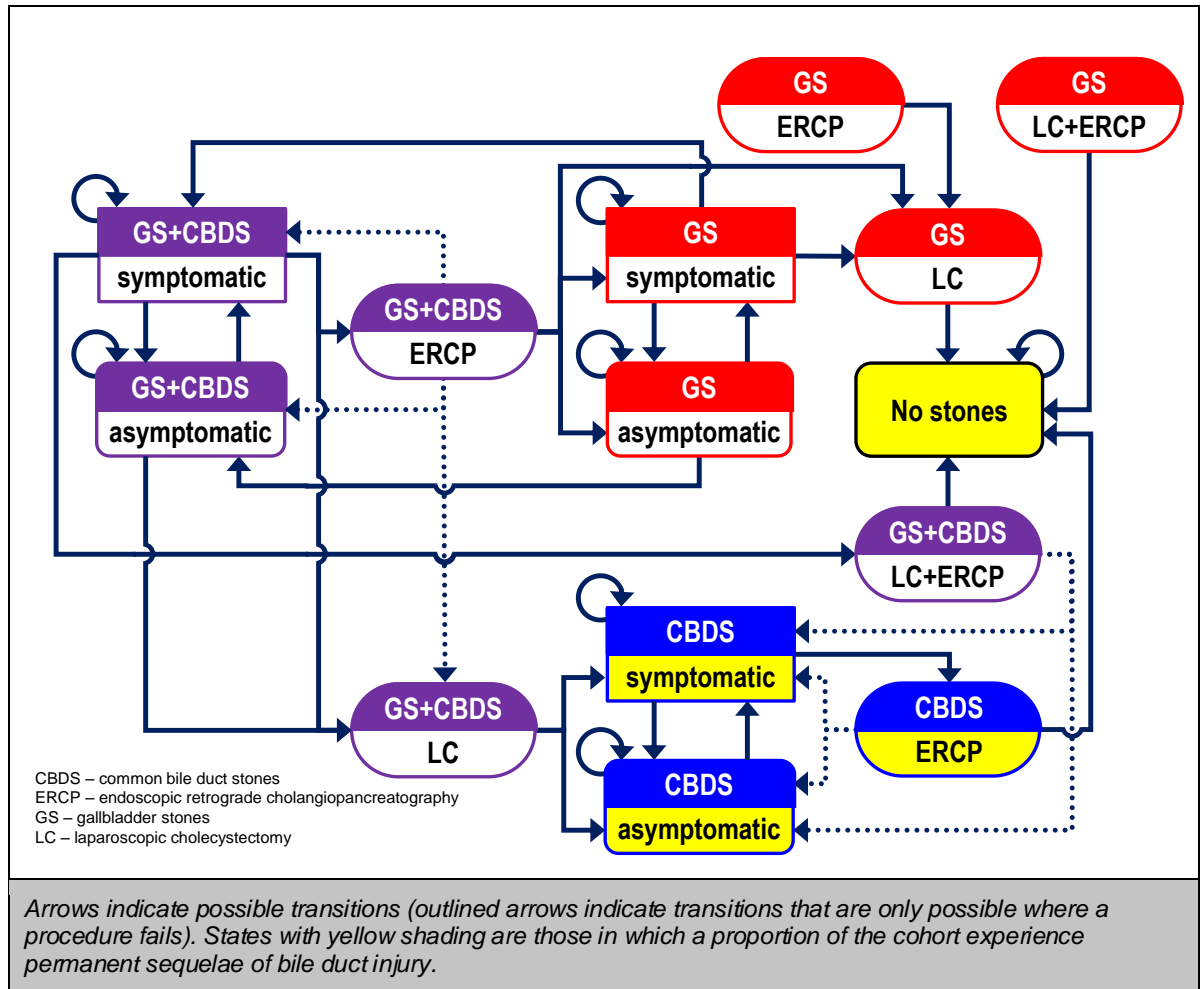

10 **Figure 2: Possible states and transitions for gallstones Markov model**

- 11 All intervention states have a risk of death, as does the symptomatic pancreatitis state, that are not listed in the transitions described below. All states include a risk of background mortality.
- 12
- 13
- 14 Known CBDS are dealt with by one or two ERCs. The model does not contain a state to represent these second ERCs, they are modelled as cost and utility impacts for the percentage of patients receiving them.
- 15
- 16

**2.311 Laparoscopic cholecystectomy with intraoperative cholangiography versus laparoscopic cholecystectomy (Q4b.1)**

3 Available transitions for both arms of this question (Figure 3) are the same. However, the  
4 initial states differ, as do the transition probabilities. Laparoscopic cholecystectomy with  
5 intraoperative cholangiography (IOC) is modelled via the laparoscopic cholecystectomy  
6 states, but with different transition probabilities and costs.

7 Laparoscopic cholecystectomy patients begin in the laparoscopic cholecystectomy states  
8 with either gallstones or gallstones and CBDS. Patients with gallstones and CBDS start in  
9 either the laparoscopic cholecystectomy+ERCP state (where the IOC does find CBDS) or the  
10 laparoscopic cholecystectomy state (where the IOC does not find CBDS)<sup>a</sup>.

11 Patients starting in the gallstones only state transition from laparoscopic cholecystectomy to  
12 the 'no stones' state, with or without a bile duct injury, where they remain until they die of  
13 natural causes. Patients with gallstones and CBDS who start in the laparoscopic  
14 cholecystectomy+ERCP state have similar transitions available.

15 Patients with gallstones and CBDS who start in the laparoscopic cholecystectomy only state  
16 (ie the IOC does not find CBDS, even though they exist) transition to the CBDS  
17 asymptomatic and symptomatic states, with or without bile duct injury. Patients with  
18 asymptomatic CBDS can remain asymptomatic or transition to symptoms. Once patients are  
19 in symptomatic CBDS states, they transition to ERCP. Following an ERCP, patients can  
20 transition to 'no stones and asymptomatic' or may have remaining unknown CBDS  
21 (asymptomatic or symptomatic). Those with remaining CBDS will receive an ERCP when the  
22 CBDS cause symptoms.

---

a It is important to remember that the model 'knows' whether a patient has CBDS, even if they are not known or found at the initial investigation.

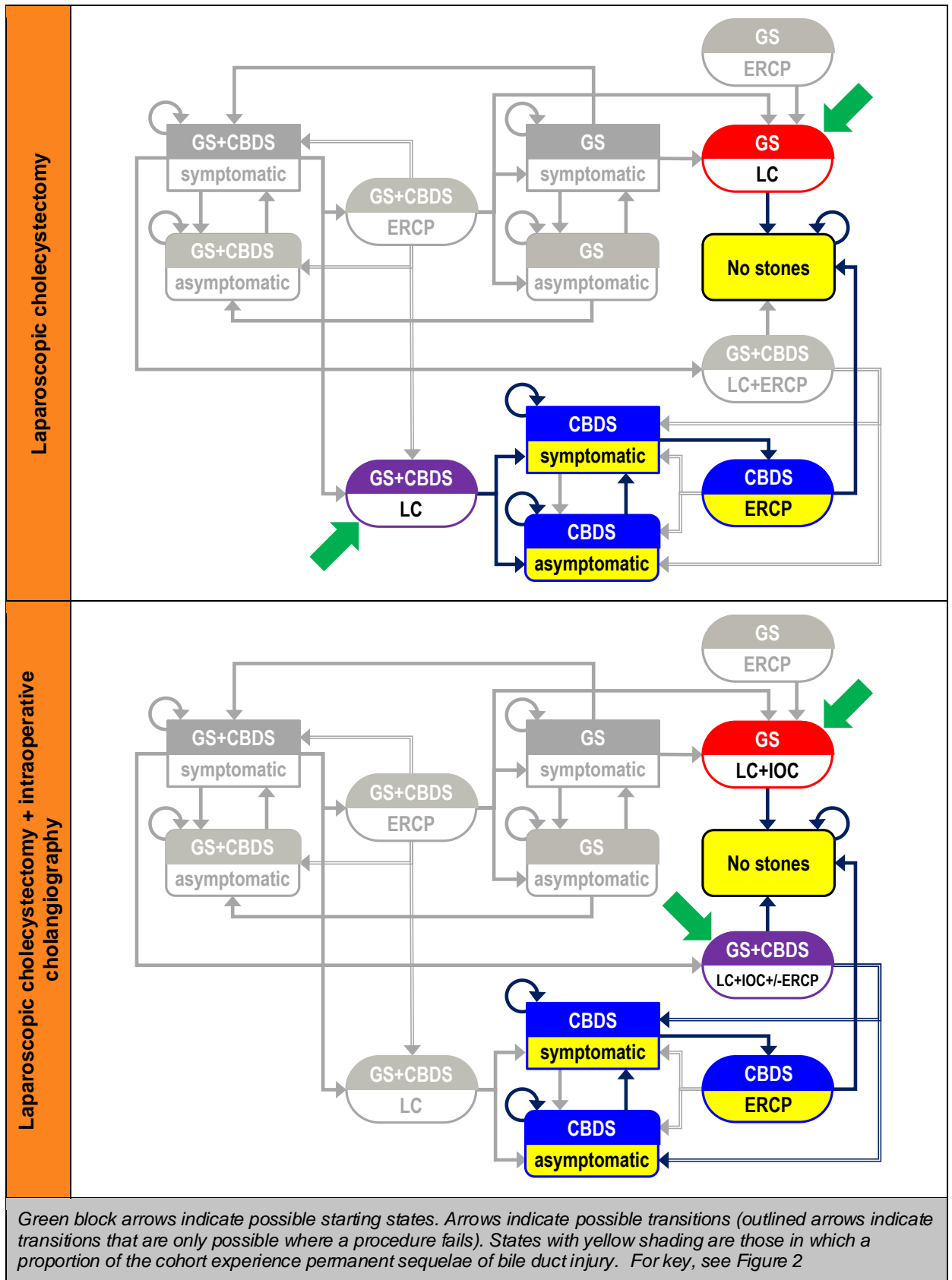

1 **Figure 3: Model structure for question Q4b.1 – laparoscopic cholecystectomy with**  
 2 **intraoperative cholangiography versus laparoscopic cholecystectomy**

### **2.3.12 Laparoscopic cholecystectomy versus conservative management (Q4b.2)**

- 2 Transitions for the laparoscopic cholecystectomy arm are the same as for the laparoscopic  
3 cholecystectomy arm in Q4b.1 (see section 2.3.1).
- 4 Patients in the conservative management arm start in any of the symptomatic states. They  
5 can remain symptomatic, transition to asymptomatic or transition to receiving an intervention  
6 (see Table 5). Patients with gallstones only may develop new asymptomatic or symptomatic  
7 CBDS (transition from gallstones only to gallstone and CBDS states).
- 8 Patients in the gallstones only state transition from laparoscopic cholecystectomy to the ‘no  
9 stones’ state, with or without a bile duct injury, where they remain until they die of natural  
10 causes.
- 11 Patients in the gallstones and CBDS state who transition from laparoscopic cholecystectomy  
12 go to the asymptomatic or symptomatic CBDS states (with or without a bile duct injury).  
13 Patients in the gallstones and CBDS state who transition from ERCP go to either  
14 asymptomatic or symptomatic gallstones or asymptomatic or symptomatic gallstones and  
15 CBDS (if unknown stones remain). From any of these states, patients may again remain  
16 symptomatic, become asymptomatic or receive an intervention.
- 17 Once patients reach the CBDS asymptomatic and symptomatic states (with or without bile  
18 duct injury) they remain asymptomatic or transition to symptoms. Once patients are in  
19 symptomatic CBDS states, they transition to ERCP. Following an ERCP, patients can  
20 transition to ‘no stones and asymptomatic’ or may have remaining unknown CBDS  
21 (asymptomatic or symptomatic). Those with remaining CBDS will receive an ERCP when the  
22 CBDS cause symptoms.

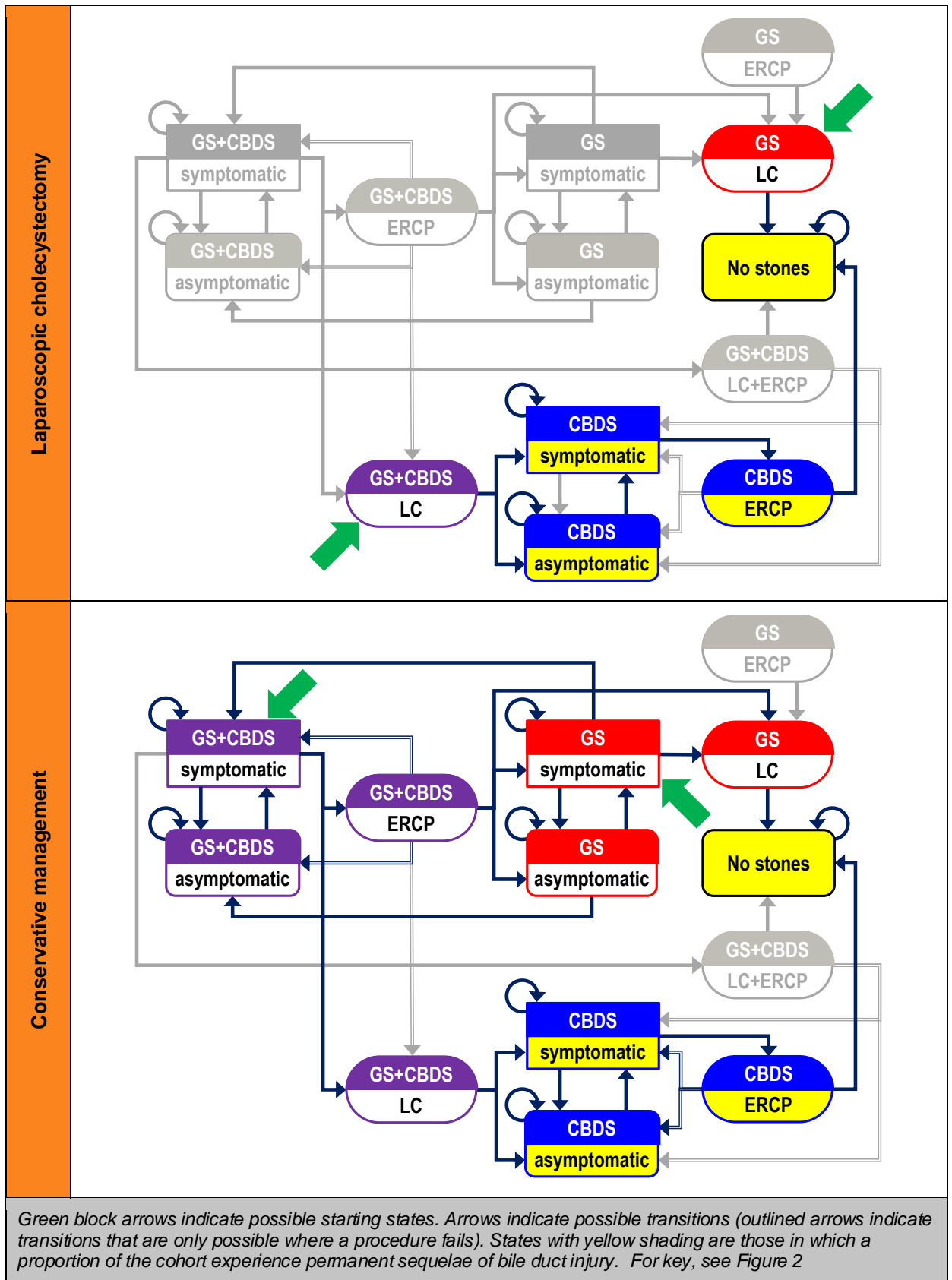

1 **Figure 4: Model structure for question Q4b.2 – laparoscopic cholecystectomy versus**  
 2 **conservative management**



**2.3.13 Day-case versus inpatient laparoscopic cholecystectomy (Q4b.3)**

- 2 Transitions for both the day-case and inpatient laparoscopic cholecystectomy arms (Figure
- 3 5) are the same as for the laparoscopic cholecystectomy arm in Q4b.1 (see section 2.3.1).
- 4 Transition probabilities, costs and utilities differ between arms.
- 5

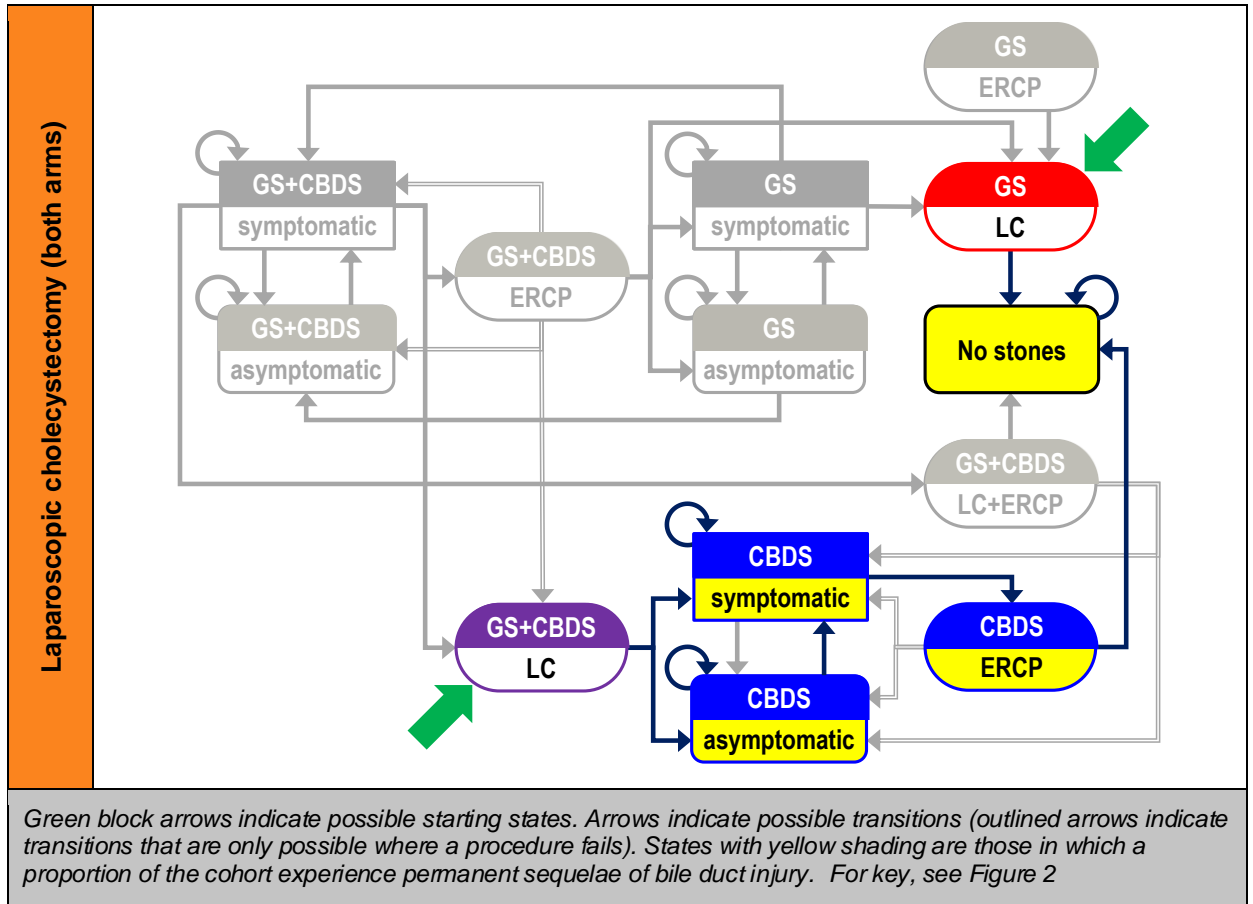

6 **Figure 5: Model structure for question Q4b.3 – day-case versus inpatient laparoscopic**  
 7 **cholecystectomy**  
 8

**2.314 Laparoscopic cholecystectomy with bile duct exploration versus laparoscopic cholecystectomy with pre-, intra- or postoperative ERCP (Q4c.1)**

2

3 This question explores 4 different approaches to the management of people who are  
4 suspected of symptomatic CBDS.

5 Patients in the laparoscopic cholecystectomy with bile duct exploration arm begin the  
6 laparoscopic cholecystectomy states with either gallstones only or gallstones and CBDS.  
7 They follow the transitions outlined for the laparoscopic cholecystectomy arm of question  
8 Q4b.1 (see section 2.3.1), but as bile duct exploration is undertaken, those starting with  
9 gallstones and CBDS are able to transition to the asymptomatic no stones state (with or  
10 without bile duct injury). In a proportion of patients, CBDS remain undiscovered; these  
11 people enter the CBDS only section of the model and receive ERCP if and when they  
12 become symptomatic; assuming the ERCP is successful, they move to 'no stones' where  
13 they remain until they die of background mortality.

14 Patients in the preoperative ERCP arm start in the ERCP states with either gallstones only or  
15 gallstones and CBDS. They receive a laparoscopic cholecystectomy in the second cycle.  
16 Patients with no new or remaining unknown CBDS transition to the asymptomatic 'no stones'  
17 state (with or without bile duct injury). Patients with new or remaining unknown CBDS will  
18 receive an ERCP when the CBDS cause symptoms. Following an ERCP, patients can  
19 transition to 'no stones and asymptomatic' or may have remaining unknown CBDS  
20 (asymptomatic or symptomatic)

21 In the laparoscopic cholecystectomy with intraoperative ERCP arm, patients follow  
22 analogous transitions to those in the laparoscopic cholecystectomy with bile duct exploration  
23 arm. This is also true in the laparoscopic cholecystectomy with postoperative ERCP arm, as  
24 both procedures are assumed to take place during the same 2-week model cycle; however,  
25 costs, quality of life and exit probabilities are different from the intraoperative variant.

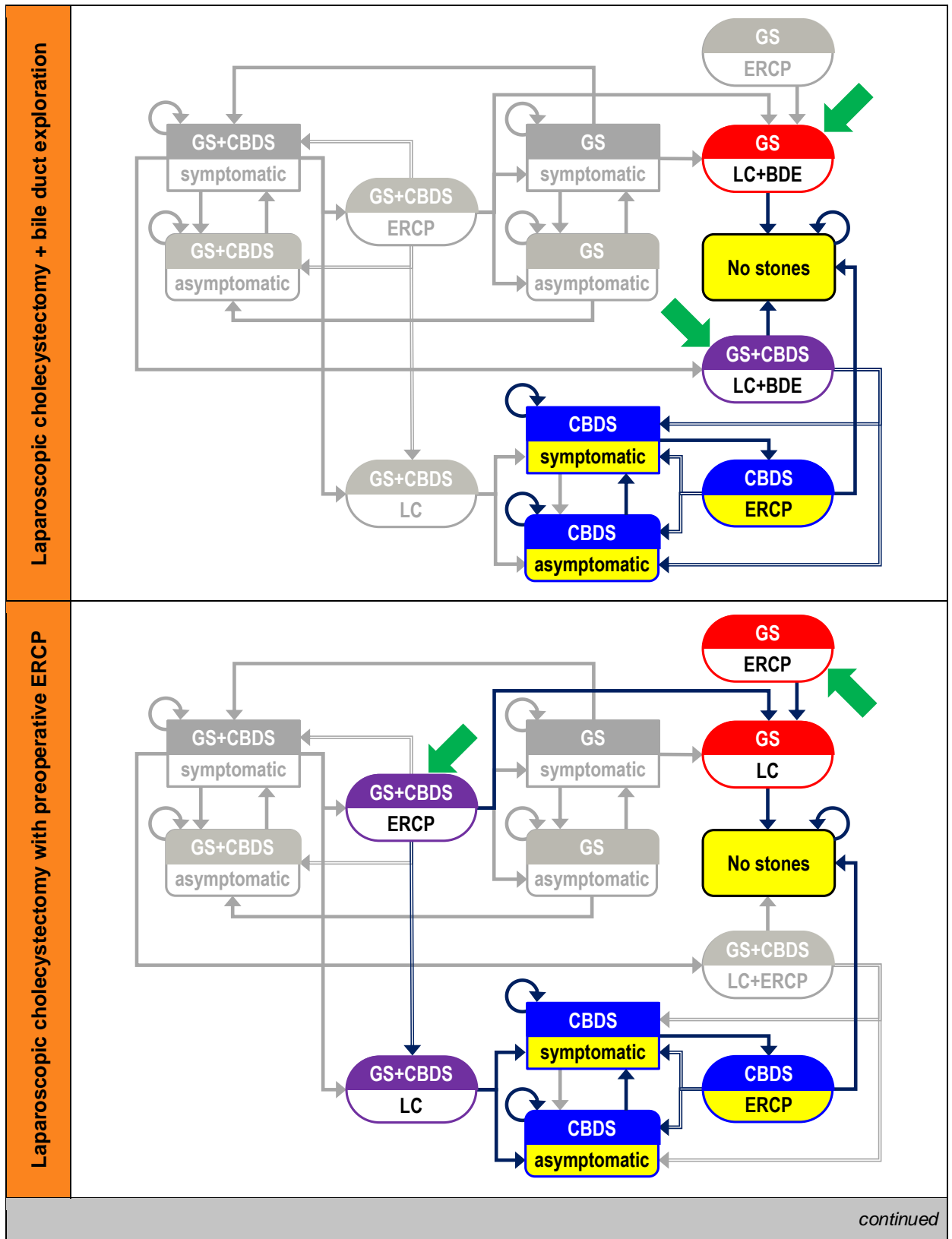

continued

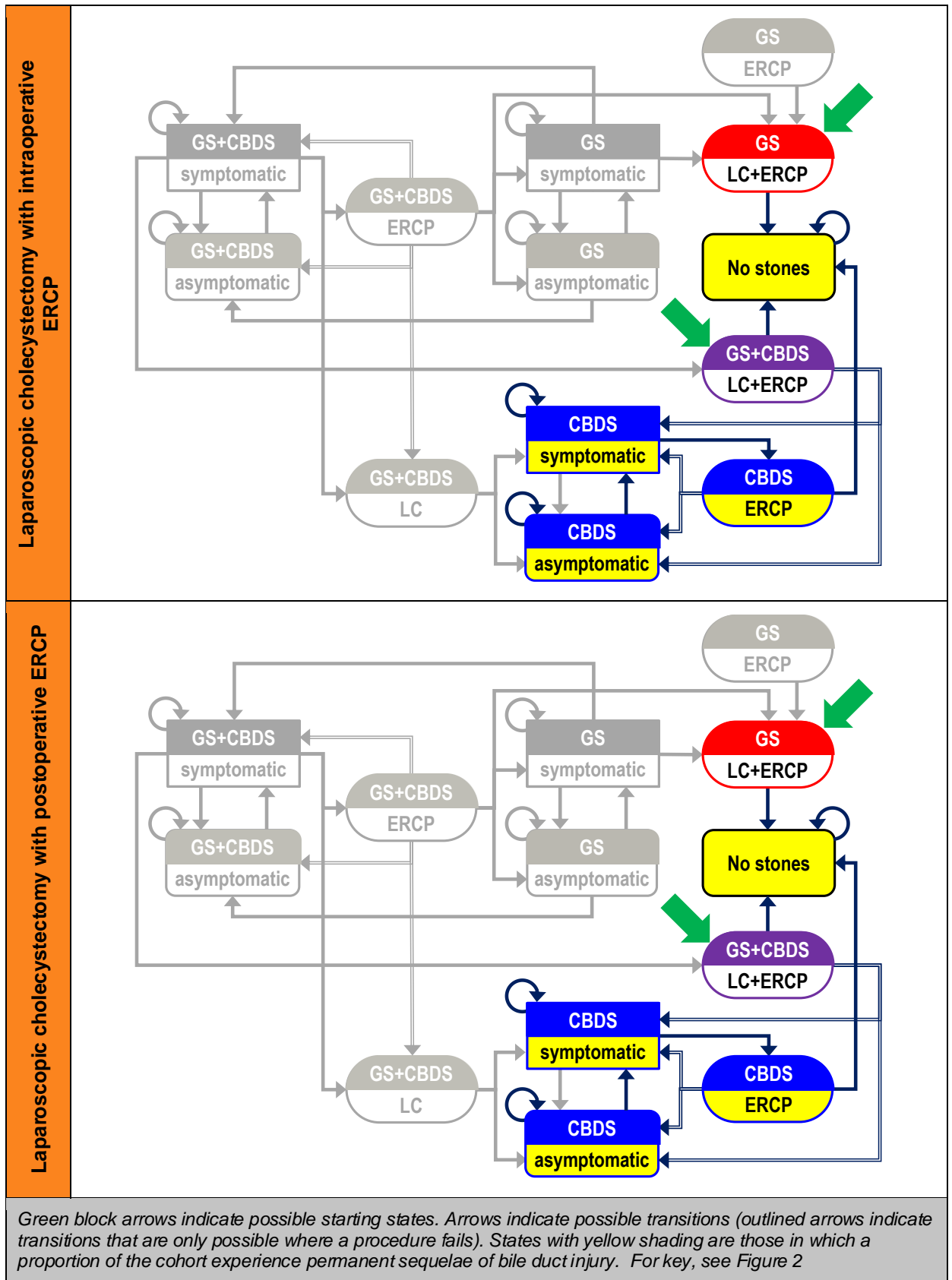

Green block arrows indicate possible starting states. Arrows indicate possible transitions (outlined arrows indicate transitions that are only possible where a procedure fails). States with yellow shading are those in which a proportion of the cohort experience permanent sequelae of bile duct injury. For key, see Figure 2

1 **Figure 6: Model structure for question Q4c.1 – laparoscopic cholecystectomy with bile**  
 2 **duct exploration versus laparoscopic cholecystectomy with pre-, intra- or**  
 3 **post-operative ERCP**

### **2.315 ERCP and laparoscopic cholecystectomy versus ERCP alone (Q4c.2)**

- 2 The two clinical included studies (Boerma et al. 2002; Lau et al. 2006) enrolled patients who  
3 had undergone an ERCP and had their bile ducts cleared. Therefore, these patients can  
4 have no remaining unknown CBDS and all start in the gallbladder stone states.
- 5 In the ERCP and laparoscopic cholecystectomy arm, all patients start in the laparoscopic  
6 cholecystectomy state and can only transition to no stones with or without a bile duct injury,  
7 where they remain until they die of natural causes.
- 8 Patients in the ERCP alone arm start in the asymptomatic, biliary colic or acute cholecystitis  
9 states. During the model, asymptomatic patients can become symptomatic, and symptomatic  
10 patients transition to the laparoscopic cholecystectomy state.
- 11 Prior to laparoscopic cholecystectomy, patients can develop asymptomatic or symptomatic  
12 new CBDS. Once these become symptomatic, patients transition to the intervention  
13 appropriate to their symptom (see Table 5). If this intervention is a laparoscopic  
14 cholecystectomy, patients transition to asymptomatic or symptomatic CBDS states where  
15 they remain asymptomatic or transition to symptoms. If the intervention is an ERCP, patients  
16 transition to asymptomatic or symptomatic gallstone states and follow the starting transitions  
17 outlined above, or transition to asymptomatic or symptomatic gallstones and CBDS states (if  
18 unknown CBDS remain) and follow the transitions above for new CBDS.
- 19 Once patients are in symptomatic CBDS states, they transition to ERCP and then to 'no  
20 stones and asymptomatic' or may have remaining unknown CBDS (asymptomatic or  
21 symptomatic). Those with remaining CBDS will receive an ERCP when the CBDS cause  
22 symptoms.



### 2.3.16 ERCP versus conservative management (Q4c.3)

- 2 In the ERCP arm, patients start in the ERCP states with either gallstones alone or gallstones  
3 and CBDS and transition to asymptomatic or symptomatic states. Those with gallstones  
4 alone transition to gallstones states, unless new CBDS develop in which case they transition  
5 to gallstones and CBDS states. Those who begin with gallstones and CBDS transition to  
6 gallstones alone unless they have remaining unknown stones.
- 7 If patients are in symptomatic biliary colic states they can become asymptomatic, remain  
8 symptomatic or receive a laparoscopic cholecystectomy. Those in symptomatic acute  
9 cholecystitis states all transition to laparoscopic cholecystectomy states; those in  
10 symptomatic cholangitis, jaundice, pancreatitis or sepsis states transition to ERCP states.
- 11 Patients with gallstones only who transition to laparoscopic cholecystectomy can only  
12 transition to no stones with or without a bile duct injury, where they remain until they die of  
13 natural causes. Patients with gallstones and CBDS transition to asymptomatic or  
14 symptomatic CBDS states. Patients who transition to ERCP can have remaining unknown  
15 stones and follow the starting transitions outlined above.
- 16 Once patients are in symptomatic CBDS states, they transition to ERCP and then to 'no  
17 stones and asymptomatic' or may have remaining unknown CBDS (asymptomatic or  
18 symptomatic). Those with remaining CBDS will receive an ERCP when the CBDS cause  
19 symptoms.
- 20 Following the GDG's advice, all patients who have not yet transitioned through a  
21 laparoscopic cholecystectomy state are forced to do so in cycle 4 (representing 6–8 weeks  
22 after their initial ERCP).
- 23 In the conservative management arm, patients start in any of the symptomatic states. They  
24 follow the transitions outlined above for the conservative management arm in question 4b.2  
25 (see section 2.3.2).

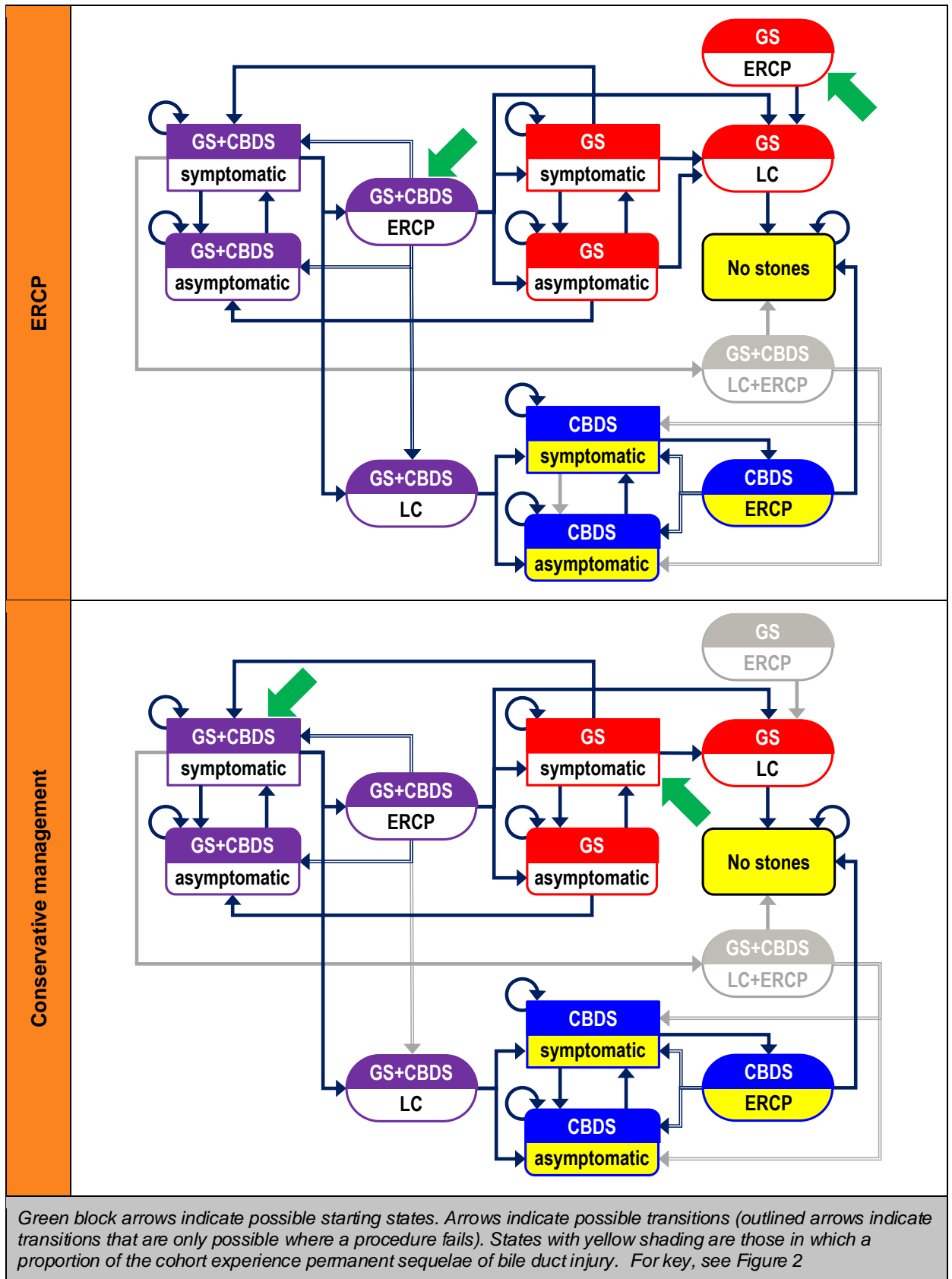

1 **Figure 8: Model structure for question Q4c.3 – ERCP versus conservative**  
 2 **management**



### **2.3.17 Early versus delayed laparoscopic cholecystectomy (Q5a.1)**

2 In the early laparoscopic cholecystectomy arm, patients begin in the laparoscopic  
3 cholecystectomy states with either gallstones or gallstones and CBDS. Patients follow the  
4 transitions outlined above in the laparoscopic cholecystectomy arm of question Q4b.1 (see  
5 section 2.3.1).

6 Patients in the delayed laparoscopic cholecystectomy arm begin in any of the symptomatic  
7 states. If they have biliary colic, they can become asymptomatic, remain symptomatic or  
8 receive a laparoscopic cholecystectomy. Symptomatic acute cholecystitis patients receive a  
9 laparoscopic cholecystectomy; patients with other symptoms receive an ERCP (see Table 5)  
10 and a laparoscopic cholecystectomy in the same cycle. Patients can transition to 'no stones  
11 and asymptomatic' or may have remaining unknown CBDS (asymptomatic or symptomatic).  
12 Those with remaining CBDS will receive an ERCP when the CBDS cause symptoms. All  
13 patients who have not yet done so receive a laparoscopic cholecystectomy in cycle 4  
14 (following a 6-8 delay), irrespective of asymptomatic or symptomatic states.

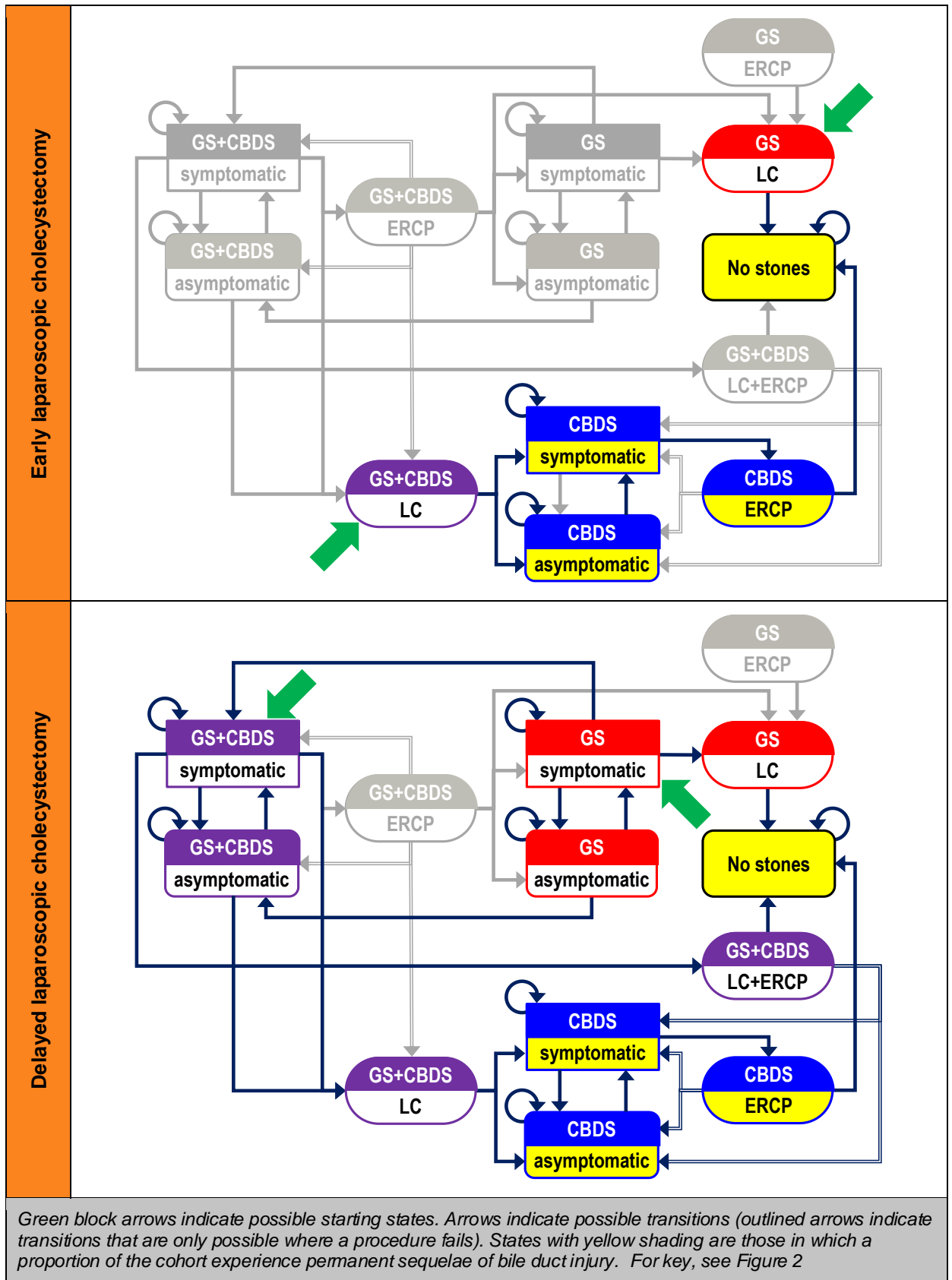

1 **Figure 9: Model structure for question Q5a.1 – early versus delayed laparoscopic**  
 2 **cholecystectomy**

**2.3.18 Early versus delayed laparoscopic cholecystectomy following ERCP (Q5a.2)**

2 In this question of laparoscopic cholecystectomy timing post ERCP, patients are assumed to  
3 have a cleared common bile duct with no remaining unknown CBDS, but the potential for  
4 new CBDS to have developed since the ERCP was undertaken (presumed to be in the  
5 previous “cycle” to the start of the model). In the early arm, patients begin in the laparoscopic  
6 cholecystectomy states, with either gallstones only or gallstones and CBDS. Patients follow  
7 the transitions outlined above in the laparoscopic cholecystectomy arm of question Q4b.1  
8 (see section 2.3.1).

9 Patients in the delayed laparoscopic cholecystectomy arm begin in the asymptomatic or  
10 symptomatic states with either gallstones only or gallstones and CBDS (new CBDS that have  
11 developed since the ERCP occurred and newly developed symptoms). They follow the  
12 transitions outlined in delayed laparoscopic cholecystectomy arm of questions Q5a.1 (see  
13 section 2.3.7).

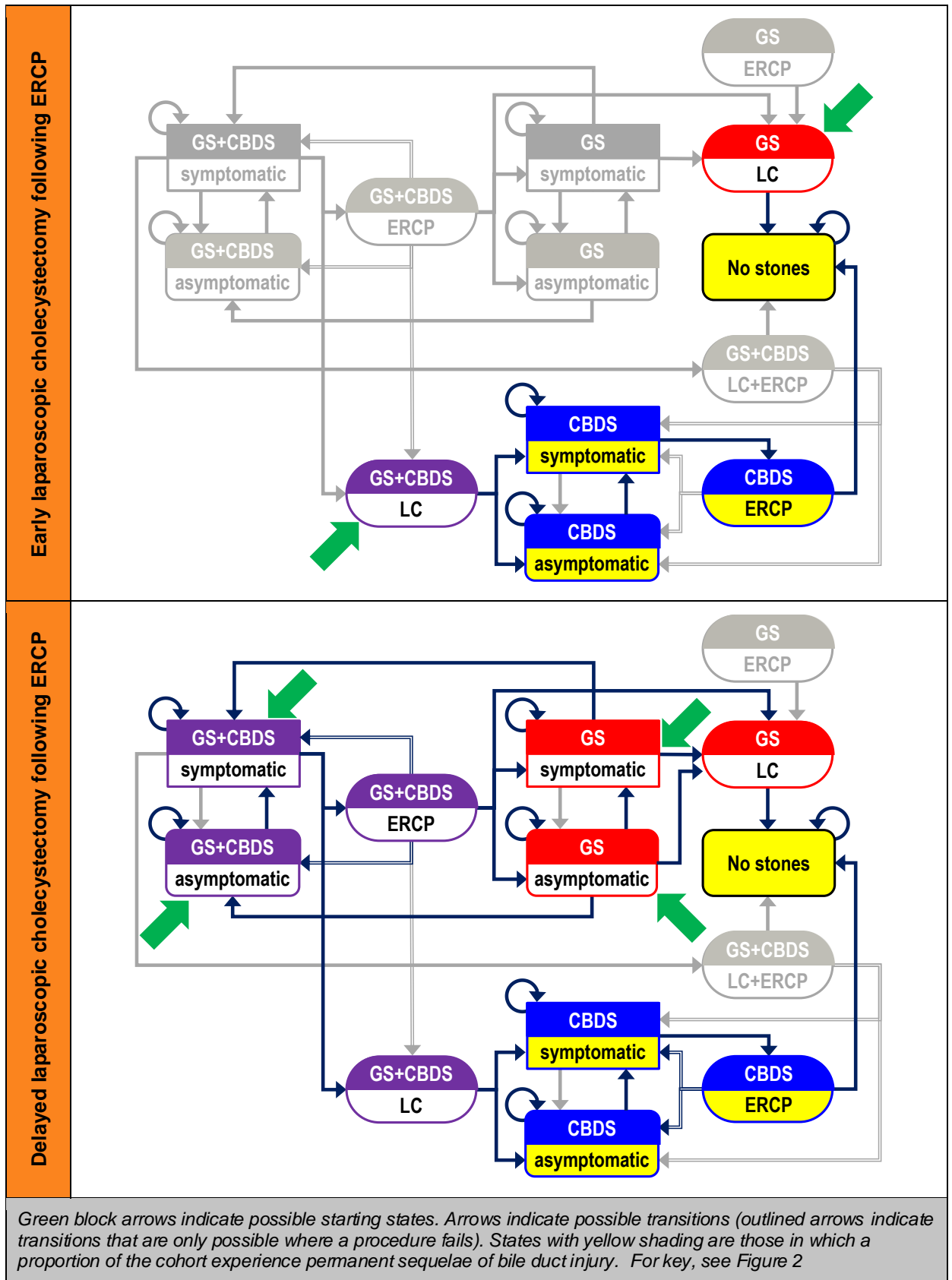

1 **Figure 10: Model structure for question 5a.2 – early versus delayed laparoscopic**  
 2 **cholecystectomy following ERCP**

## 2.4 Model Parameters

2 All model parameters are listed in Table 19, with their sources and, where applicable, the  
3 distributions and parameters used to reflect uncertainty around their true value in  
4 probabilistic sensitivity analyses. Where possible, model parameters were sourced from the  
5 studies included in the systematic reviews of clinical evidence undertaken for this guideline.  
6 Other parameters were identified through informal searches that aimed to satisfy the  
7 principle of 'saturation' (that is, to 'identify the breadth of information needs relevant to a  
8 model and sufficient information such that further efforts to identify more information would  
9 add nothing to the analysis' (Kaltenhaler et al, 2011).

### 2.401 Initial patient distributions

11 As they enter the model, patients are split between having gallstones only or gallstones and  
12 CBDS, on the basis of their underlying gallstones pathology rather than whether their CBDS  
13 are known to the patient or clinician (see section 2.1). Therefore, whether or not patients  
14 have CBDS is based on the percentage of patients who were found to have CBDS and those  
15 who had remaining unknown CBDS (at ERCP or bile duct exploration).

16 On GDG advice, patient cohorts are assumed to be 75% female and have a mean age of 50  
17 years. These assumptions only impact the background mortality risk and utility values and  
18 are tested in sensitivity analyses.

### 2.402 Probabilities of having or developing symptoms

20 Symptoms are specific to having gallstones only, gallstones and CBDS or CBDS only (see  
21 Table 5).

22 In arms where patients begin with symptoms, symptoms are mutually exclusive and  
23 exhaustive. None of the included clinical studies of patients with gallstones reported  
24 symptoms at baseline. Data on the numbers of patients developing symptoms were used to  
25 weight symptoms between biliary colic (62%) and acute cholecystitis at (38%) baseline and  
26 agreed by the GDG.

27 None of the included clinical studies of patients with gallstones and CBDS reported patients  
28 with symptomatic sepsis. The GDG felt this was unlikely and 25% of patients were assumed  
29 to have sepsis at baseline. For both baseline gallstone and CBDS, symptoms were  
30 constrained to equal 100%

31 The incidence of patients developing symptoms during treatment delay, conservative  
32 management or following treatment were calculated as rates, based on reported or  
33 calculated lengths of patient follow-up. Data from one included clinical study could not be  
34 used as no follow-up data were reported (Fan et al. 1993).

35 Pancreatitis carries a risk of mortality that is parameterised from a comparative study of  
36 pancreatitis mortality in England and Australia (Chiang et al. 2004).

37 Gallbladder cancer incidence in patients with gallstones is parameterised from a study  
38 included in guideline question 3 on the management asymptomatic gallstones (Attili et al.  
39 1995). Gallbladder cancer mortality rates for England were provided by the North West  
40 Cancer Registry (North West Cancer Intelligence Service 2014).

### 2.413 Baseline event probabilities

42 All treatment effects are drawn from included RCTs, which means they come in the form of  
43 comparative effectiveness estimates (for example, people receiving treatment *a* are twice as  
44 likely to experience a given outcome than people receiving treatment *b*). In order to estimate  
45 transition probabilities, it is necessary to combine these relative effectiveness data with an

1 estimate of absolute 'baseline' event probability (twice as likely as *what?*) In combination,  
2 these data provide estimates of absolute event probabilities for all the simulated treatments.

3 Evidence to inform absolute baseline event probabilities may be drawn from a variety of  
4 sources (Dias et al. 2012); we chose to pool the relevant arms of RCTs from the systematic  
5 review of relative effectiveness data. All questions addressed in this model include 1 of 2  
6 standard treatment choices – for questions about gallbladder stones, this is a standard  
7 laparoscopic cholecystectomy; for questions about common bile duct stones, it is a standard  
8 ERCP.

9 To increase parameter accuracy, data from standard laparoscopic cholecystectomy arms  
10 were pooled and applied in all relevant questions (see **Error! Reference source not  
11 ound.**). Symptoms and consequences were specific to gallstones only or gallstones and  
12 CBDS comparisons.

13 **Table 7: Arms combined to produce baseline generic laparoscopic cholecystectomy**  
14 **transition probabilities**

Question Number	Question	Standard Laparoscopic Cholecystectomy Arm
Q4b.1	Laparoscopic cholecystectomy with IOC versus laparoscopic cholecystectomy	Laparoscopic cholecystectomy
Q4b.2	Laparoscopic cholecystectomy versus Conservative Management	Laparoscopic cholecystectomy
Q4b.3	Inpatient versus Day-case laparoscopic cholecystectomy	Inpatient laparoscopic cholecystectomy
Q5a.1	Early versus delayed laparoscopic cholecystectomy	Delayed laparoscopic cholecystectomy
Q5a.2	Early versus delayed laparoscopic cholecystectomy following ERCP	Delayed laparoscopic cholecystectomy

#### 2.454 Probabilities of operative consequences

16 The range of operative consequences considered was based on those reported in the  
17 included clinical studies and agreed with the GDG. Some operative consequences impacted  
18 model transitions whereas some were modelled as cost and/or utility impacts only. Table 8  
19 summarises the operative consequences modelled and their scope.

20 Operative consequence data were meta-analysed where appropriate against the comparator  
21 arm (see Table 2) to give natural log odds and natural log odds ratios (as reported in Table  
22 19).

23 Where data were available in the included studies, inter-arm differences in operative  
24 consequences were modelled. Where comparative data were not available, operative  
25 consequences for a standard laparoscopic cholecystectomy or ERCP were assumed.

1 **Table 8: Operative consequences included in the gallstones model**

Condition and Operation	Consequence	Scope
Gallstones – laparoscopic cholecystectomy	Bile duct injury	Transition, utility
	Bile leak requiring ERCP	Cost, utility, mortality
	Extra ERCP required to clear CBD	Cost, utility, mortality
	Laparoscopic cholecystectomy required (delayed or conservative management arms only)	Transition, cost, utility and mortality
	Laparoscopic to open cholecystectomy conversion	Cost
	Unknown CBDS	Transition, cost, utility
	Laparoscopic cholecystectomy operative mortality	Transition
Gallstones and CBDS – ERCP	Bile leak requiring extra ERCP	Transition, cost, utility and mortality
	ERCP required (delayed or conservative management arms only)	Transition, cost, utility and mortality
	Extra ERCP required to clear CBD	Cost, utility, mortality
	Laparoscopic cholecystectomy required (delayed or conservative management arms only)	Transition, cost, utility and mortality
	Laparoscopic to open cholecystectomy conversion	Cost
	New CBDS	Transition
	Unknown CBDS	Transition, cost, utility
	ERCP operative mortality	Transition

2

3 Some reported operative consequences were not included in the model. For the laparoscopic  
4 cholecystectomy with intraoperative ERCP comparison (Q4c.1), switches to bile duct  
5 exploration were not modelled, as the model assumes intraoperative ERCP and bile duct  
6 exploration have the same cost and utility decrement. Known missed CBDS were not  
7 modelled, as it was felt this would double count with extra ERCPs required.

8 Operative mortality is parameterised from data external to the included clinical studies. There  
9 was no laparoscopic cholecystectomy mortality in the included studies and none of the  
10 included studies identified only operative mortality for ERCPs. The GDG felt it was important  
11 to include a measure of operative mortality. Data from a mid 1990s Royal College of  
12 Surgeons audit gave a laparoscopic cholecystectomy mortality rate similar to that suggested  
13 by the GDG (Dunn et al. 1994). Similarly, an overall ERCP operative mortality rate similar to  
14 that suggested by the GDG was taken from a 2004 British Society of Gastroenterology audit  
15 (Willams et al. 2006). Background mortality is taken from Office for National Statistics Life  
16 Tables (Office for National Statistics 2013).

17 Question 4c.1 compares laparoscopic cholecystectomy with bile duct exploration to  
18 laparoscopic cholecystectomy with pre, intra or postoperative ERCP. An indirect comparison  
19 was undertaken in the clinical evidence review (see guideline section 4.6) – the model uses  
20 direct evidence unless only indirect evidence is available.

## 2.4.15 Costs and Resource Use

- 2 Operative costs are based on NHS reference costs 2011-12 (Department of Health 2012).  
 3 Appropriate healthcare resource groupings (HRGs) were identified using OPCS4<sup>b</sup> operation  
 4 codes J18.3 for laparoscopic cholecystectomy and J43.9 for ERCP.

5 **Table 9: HRGs Used to Cost Laparoscopic Cholecystectomy Operations**

Operation	HRG Code	HRG Description
Standard laparoscopic cholecystectomy	GA10D	Laparoscopic Cholecystectomy, 19 years and over, with length of stay 1 day or more, without CC
	GA10E	Laparoscopic Cholecystectomy, 19 years and over, with length of stay 0 days, without CC
Complicated laparoscopic cholecystectomy (laparoscopic to open conversion)	GA10F	Open or Laparoscopic Cholecystectomy, 19 years and over with CC
Laparoscopic cholecystectomy with bile duct exploration or intraoperative ERCP	GA07A	Intermediate Open Hepatobiliary or Pancreatic Procedures, with CC
	GA07B	Intermediate Open Hepatobiliary or Pancreatic Procedures, without CC

6 (a) CC: complications and/or comorbidities

- 7 Using reference costs, it is possible to differentiate between standard, complicated and  
 8 laparoscopic cholecystectomy operations that contains intraoperative bile duct activity, but  
 9 not between operations containing bile duct exploration and intraoperative ERCP.

10 The GDG identified length of stay as a critical outcome. Accordingly, reference costs are  
 11 broken down into fixed and bed day costs for laparoscopic cholecystectomy and ERCP. This  
 12 assumes that the extra cost of a non-elective operation is entirely due to the additional length  
 13 of stay, rather than operative costs. The average finished consultant episode (FCE) cost and  
 14 length of stay of all elective and non-elective laparoscopic cholecystectomies was calculated  
 15 and a cost per bed day can be ascertained (see Table 10). Similarly, the fixed and bed day  
 16 costs of an ERCP were derived (see Table 11). Using these fixed and bed day costs and the  
 17 average length of stay, baseline costs for each operation are calculated and shown in Table  
 18 12. For the laparoscopic cholecystectomy with ERCP state, the two interventions are  
 19 assumed to occur in the same hospital admission. Here, a baseline length of stay of 5 days  
 20 was assumed by the GDG.

21 **Table 10: Derivation of Fixed and Bed Day Costs for Laparoscopic Cholecystectomy**

Laparoscopic Cholecystectomy Costs	Elective	Non-Elective
Average FCE cost	£2,269	£3,614
Average length of stay (days)	1.47	4.98
Fixed Cost (assume equal)	£1,708	
Bed day cost (assume equal)	£383	

22 **Table 11: Derivation of Fixed and Bed Day Costs for ERCP**

ERCP Costs	Elective	Non-Elective
Average FCE cost	£1,042	£2,471
Average length of stay (days)	1.42	6.11
Fixed Cost (assume equal)	£610	
Bed day cost (assume equal)	£305	

<sup>b</sup> Office of Population Censuses and Surveys Classification of Surgical Operations and Procedures (4th revision)



1 **Table 12: Baseline Operation Length of Stay and Cost**

Operation	Length of Stay	Baseline Cost
Standard laparoscopic cholecystectomy	1.14	£2,416
Complicated laparoscopic cholecystectomy (conversion)	1.88	£2,429
Laparoscopic cholecystectomy with bile duct exploration or intraoperative ERCP	3.59	£3,081
ERCP (elective)	1.42	£1,042
ERCP (non-elective)	6.11	£2,471
Laparoscopic cholecystectomy and ERCP in same admission	5.00 (assumed)	£4,231

2 It is necessary to make some assumptions with regard to whether the interventions in the  
3 model are performed as elective (planned) or non-elective surgery. Hospital episode  
4 statistics (NHS Information Centre for Health and Social Care 2014) indicate that 91% of  
5 laparoscopic cholecystectomies and 75% of ERCPs are performed electively. Therefore, the  
6 model is based on the following assumptions:

- 7 1. All interventions on entry to the model are performed electively
- 8 2. All laparoscopic cholecystectomies are performed electively
- 9 3. ERCPs occurring within the model are non-elective, unless:
  - 10 a. As a result of 'extra ERCP required' to clear common bile duct (all questions)
  - 11 b. Following intraoperative cholangiography (Q4b.1)
  - 12 c. Within laparoscopic cholecystectomy with postoperative ERCP arm (Q4c.1)

13 Incremental length of stay changes were applied to the baseline lengths of stay for  
14 laparoscopic cholecystectomy and ERCP, based on the clinical evidence analysis (see  
15 appendix H). Incremental and total lengths of stay and operative costs are shown in Table 13  
16 (based on one intervention in a given admission).

17 Laparoscopic cholecystectomy with intraoperative cholangiography (Q4b.1) is also assumed  
18 to require 15 minutes of a radiographer's time in addition to the basic laparoscopic  
19 cholecystectomy costs.

20 Asymptomatic and symptomatic states are assumed to incur no costs, as the cost of any  
21 intervention to deal with the symptoms is incurred in the following cycle.

22 The additional cost of a conversion from laparoscopic to open cholecystectomy was  
23 assumed to be the same for all questions.

24 The appropriate costs were applied for patients who required an extra ERCP to clear their  
25 bile duct or to deal with a bile leak.

26 Conservative management costs are based on a GDG assumption of a 7 day hospital stay –  
27 using the bed day costs in Table 10 and Table 11, this gives a cost of £2,679 for  
28 laparoscopic cholecystectomy and £2,132 for ERCP conservative management arms.

29 The costs of treating gallbladder cancer are taken as those for 'best supportive care' from a  
30 recent NICE technology appraisal of sorafenib for people with advanced hepatocellular  
31 carcinoma (National Institute for Health and Care Excellence 2010).

32 **Table 13: Length of Stay and Total Intervention Cost Per Question**

Question	Comparison	Incremental Length of Stay (days)	Total Length of Stay (days)	Total Cost
4b.1	Laparoscopic cholecystectomy versus Laparoscopic cholecystectomy with IOC	0.00	1.14	£2,154 (a)

Question	Comparison	Incremental Length of Stay (days)	Total Length of Stay (days)	Total Cost
4b.2	Laparoscopic cholecystectomy versus conservative management	0.00	1.14	£2,146 (b)
4b.3	Inpatient versus day-case Laparoscopic cholecystectomy	1.05	2.19	£2,547
4c.1	Laparoscopic cholecystectomy with preoperative ERCP	1.92	5.91	£4,145
	Laparoscopic cholecystectomy with intraoperative ERCP	0.15	3.74	£3,139
	Laparoscopic cholecystectomy with postoperative ERCP	2.50	6.09	£4,038
4c.2	ERCP with Laparoscopic cholecystectomy versus ERCP alone	3.34	4.48	£2,146
4c.3	ERCP versus conservative management	0.00	1.42	£1,042 (b) (c)
5a.1	Delayed versus early Laparoscopic cholecystectomy	3.07	4.21	£3,321
5a.2	Delayed versus early Laparoscopic cholecystectomy post ERCP	0.00	1.14	£2,146

- 1 (a) LC+IOC contains radiographer costs  
2 (b) Conservative management arm costs of 7 days hospital stay not shown  
3 (c) Elective ERCP cost shown  
4

## 2.456 Utility Values

6 Whilst undertaking the systematic review of existing health economic literature (see section  
7 1.4), it became apparent there is little utility data for gallstones that matches the NICE  
8 reference case (National Institute for Health and Care Excellence 2013). Existing CUAs  
9 utilise four main sources of utility data (Arseneau KO et al. 2001; Bass et al. 1993; Cook et  
10 al. 1994; Gregor and Ponich 1996), none of which meet the NICE reference case as none  
11 are sourced from patients with gallstones using the EQ-5D tool (see Table 14) and all were  
12 assessed to contain very serious limitations.

13 **Table 14: Utility Estimates Used by Existing CUAs**

Paper	Source	Tool
Arseneau et al. (2001)	20 healthy individuals from USA	Acute pancreatitis only using standard gamble
Bass et al. (1993)	3 experts (surgeon, radiologist, gastroenterologist)	Rating scale of 15 scenarios
Cook et al. (1994)	96 member of Australian general public	TTO of 7 scenarios
Gregor and Ponich (1996)	15 health professionals familiar with condition (Canada)	Time Trade Off of 4 scenarios

14 A literature search was undertaken to identify existing gallstones quality of life studies  
15 relevant to this guideline that returned 979 unique citations (see Table 15 for title and  
16 abstract sift results and appendix D for the search strategy). The papers used a wide variety  
17 of tools to assess the quality of life impact of gallstone disease and those using EQ5D and  
18 SF36 were prioritised.

1 **Table 15: Gallstones Quality of Life Literature Search - Articles Retained After Title and**  
 2 **Abstract Sift**

Quality of Life Measure	Number of citations
EQ5D	1
SF36	23
GIQLI	13
Other ratings scales	12
Non-numeric scales or data not available to calculate utility scores	50

3 The one EQ5D article identified (Ainslie et al. 2003) did not contain sufficient data to be  
 4 included. The Gastro-Intestinal Quality of Life Index (GIQLI, (Eypasch et al. 1995)) is a topic-  
 5 specific quality of life tool, but it does not provide a utility score between zero and one and  
 6 has not been mapped onto tools that do<sup>c</sup>. Algorithms exist that allow SF36 scores to be  
 7 mapped onto utility scores between zero and one (Ara and Brazier 2008), but only 8 of the  
 8 23 articles identified contained sufficient data from a relevant population to allow SF36 data  
 9 to be converted to a utility score (see Table 16). The 8 papers covered a variety of follow up  
 10 periods, but none exceeded 12 months (Bitzer et al. 2008; Burney and Jones 2002; de  
 11 Reuver et al. 2008; Keus et al. 2008; Moore et al. 2004; Penniston and Nakada 2007;  
 12 Quintana et al. 2003; Quintana et al. 2005).

13 Three review papers (Carraro et al. 2011; Korolija et al. 2004; Landman et al. 2012) indicated  
 14 that SF36 is a valid and recommended quality of life tool and that all main gallstone quality of  
 15 life papers have been included. Table 16 illustrates that gallstone disease quality of life  
 16 papers often compare forms of laparoscopic cholecystectomy (eg number and size of  
 17 incisions) but do not provide data specific to the states within the model. The GDG agreed  
 18 with the following assumptions that were drawn from studying the quality of life literature:

- 19 • The quality of life impact of the different forms of laparoscopic cholecystectomy included  
 20 in the model would be the same
- 21 • Gallstone symptoms have a marked impact on quality of life
- 22 • Quality of life following laparoscopic cholecystectomy returns to normal within one 4-6  
 23 weeks (the GDG agreed to model for two weeks within the model)
- 24 • Bile duct injuries have long term quality of life impact. The longest available studies  
 25 covered six years; the GDG agreed the impact would be lifelong

26 Additionally, the GDG felt there was no long term quality of life detriment attributable to living  
 27 without a gallbladder.

28 **Table 16: Summary Characteristics of Included SF36 Based Quality of Life Studies**

Paper	Sample Size	Country	Intervention	Comparator
Bitzer et al. (2008)	130	Germany	Laparoscopic cholecystectomy Prospective study	-
Burney et al. (2002)	140	USA	Inpatient laparoscopic cholecystectomy	Outpatient laparoscopic cholecystectomy (not used)
De Reuver et al. (2008)	558	Holland	Bile duct injury	No bile duct injury
Keus et al. (2008)	257	Holland	Laparoscopic cholecystectomy	Small incision cholecystectomy (not used)

c (Lee L et al. 2014) published a first attempt at mapping GIQLI to SF36. The mapping algorithm was based on small numbers of respondents and was published too late towards the end of the guideline development process to be implemented

Paper	Sample Size	Country	Intervention	Comparator
Moore et al. (2004)	196	USA	Bile duct injury	No bile duct injury
Penniston and Nakada (2007)	189	USA	Urinary stone formers	USA population norms
Quintana et al. (2003)	688	Spain	Laparoscopic cholecystectomy	Open cholecystectomy (not used)
Quintana et al. (2005)	509	Spain	Laparoscopic cholecystectomy prospective study	-

- 1 There are a number of key model states for which quality of life data has not been identified:
- 2 ○ ERCP
  - 3 ○ Asymptomatic gallstones
  - 4 ○ Specific symptomatic states

5 Rather than use utility data that does not meet the NICE reference case, the GDG were  
6 invited to suggest other diseases that have similar populations (age, gender, life  
7 expectancy), symptoms (severity, duration, recurrence) and interventions (impact, recovery)  
8 to gallstones. The GDG suggested kidney (renal) stones and appendicitis but noted that  
9 appendicitis patients tend to be younger and treated more acutely than gallstones patients.

10 A literature search was undertaken to identify existing kidney stones, urinary stones and  
11 appendicitis quality of life studies that were applicable to this guideline that returned 938  
12 unique citations (see appendix D for the search strategy). One study was found to contain  
13 urinary stone quality of life data relevant to the states within this model. (Penniston and  
14 Nakada 2007) used SF36 to compare the quality of life of patients with living with urinary  
15 stones to US population norms. Their results were converted to a utility score to give a utility  
16 decrement of 0.980. The GDG agreed this would approximate the asymptomatic gallstones  
17 state.

18 Utility values for asymptomatic patients living with no stones were taken from UK population  
19 norms (Kind et al. 1999). Other utilities were applied as decrements to this value.

20 Data from the included studies were combined at various time points, using the study sample  
21 size (see Table 17). Decrements were calculated relative to the data points for 6+weeks, so  
22 the overall decrement to the UK population norms for the symptomatic states is 0.874  
23 (0.742/0.849).

24 **Table 17: Utility Decrements For Gallstone Patients**

State	Time Period	Decrement	Number of studies
Symptomatic (all symptoms)	Preoperative	0.742	5
In hospital	1 day	0.729	1
Laparoscopic cholecystectomy	2 weeks	0.763	2
Recovered / baseline	6 weeks and over	0.849	3

25 Arm specific laparoscopic cholecystectomy decrements were calculated based on the same  
26 length of stay data as used to calculate costs. The 1 day utility decrement was applied for the  
27 length of stay, with the 2 week decrement applied for the remainder of the two week cycle. In  
28 the absence of any data, the GDG assumed ERCP would incur a utility decrement half way  
29 between laparoscopic cholecystectomy and recovered. Receiving an ERCP and  
30 laparoscopic cholecystectomy in the same hospital admission was assumed to incur an  
31 additional decrement of 0.95.

- 1 The appropriate utility decrement was applied for patients who required an extra ERCP to  
2 clear their bile duct or to deal with a bile leak.
- 3 Patients who incur a bile duct injury have a utility decrement of 0.905 for the remainder of  
4 their lives, based on the weighted average of two studies comparing patients with and  
5 without bile duct injuries (de Reuver et al. 2008; Moore et al. 2004)
- 6 Based on the same NICE technology appraisal as for costs (National Institute for Health and  
7 Care Excellence 2010), the utility decrement associated with gallbladder cancer was  
8 assumed to be 0.7.  
9

## 2.5 Model Assumptions

- 11 The health economic model of interventions to manage gallstones relies on a number of  
12 assumptions. These assumptions tend to arise for two reasons – either to reduce the model  
13 complexity or because no data point could be found in the evidence base. The assumptions  
14 were discussed with and agreed by the GDG and are listed in Table 18– the most important  
15 assumptions will be considered in the discussion (section 3.4). Where possible, a range of  
16 values for assumed inputs were tested in the sensitivity analyses.
- 17  
18

1 **Table 18: Assumptions Made in the Gallstones Health Economic Model**

Area	Assumption
Structure and inputs	Symptoms are mutually exclusive and specific to the underlying pathology (see Table 5)
	Known CBDS are cleared by a maximum of 2 ERCPs conducted within the same 2 week cycle
	Gallbladder stones are not removed without a laparoscopic cholecystectomy
	Gallbladder cancer risk only applies to those in conservative management arms (as those in delayed laparoscopic cholecystectomy will have their gallbladder removed in the future)
	Laparoscopic cholecystectomies do not routinely investigate the common bile duct for stones
Costs	Symptomatic and asymptomatic states incur no costs
	The fixed costs of elective and non-elective surgery are the same
	The fixed costs of laparoscopic cholecystectomy with intraoperative cholangiography and laparoscopic cholecystectomy with bile duct exploration are the same
	Interventions are assumed to be elective or non-elective (see section 2.4.5)
	Intraoperative cholangiography assumed to require 15 minutes of radiographer time
	Laparoscopic to open cholecystectomy conversion costs the same irrespective of laparoscopic cholecystectomy intervention
	Lengths of stay for a laparoscopic cholecystectomy and ERCP in the same hospital admission and for an initial hospital stay for conservative management are assumed
Utilities	All symptoms incur the same utility decrement
	Utility decrements are the same for gallstones and CBDS
	Post laparoscopic cholecystectomy symptoms (caused by remaining CBDS) have the same utility impact as pre laparoscopic cholecystectomy symptoms

2

## 2.6 Sensitivity Analyses

4 Sensitivity analyses were conducted to explore the various areas of uncertainty and their  
5 impact on the model. One-way sensitivity analyses (using point estimates of uncertainty only)  
6 were conducted to establish which model parameters have the greatest impact on the cost–  
7 utility results. Probabilistic sensitivity analyses were conducted using appropriate statistical  
8 distributions to vary all parameters simultaneously over 1,000 simulations. Sensitivity  
9 analyses parameters and distributions are listed in Table 19.  
10  
11

**Table 19: Gallstone Model Parameters**

Parameter	Value (95% confidence interval)	Reference	Distribution and Parameters
Discount rate:			
Costs	3.5%	NICE (2013)	
Effects	3.5%	NICE (2013)	
Sex (proportion male)	0.25	GDG assumption	
Mean age of cohort at start	50	GDG assumption	
CBDS found or Remaining Unseen Stones (initials)			
Ln(odds) with LC	-3.151 (-3.584, -2.719)	Meta Analysis (21 RCTs)	Normal: $\mu=-3.151$ ; $\sigma=0.221$
Ln(Odds) with Pre-ERCP	1.184 (0.726, 1.642)	Meta Analysis (40 RCT arms)	Normal: $\mu=1.184$ ; $\sigma=0.234$
<b>Symptoms at baseline - CBDS</b>			
Ln(Odds) Symptoms at baseline			
Acute Cholecystitis	-4.500 (-6.471, -2.529)	Noble et al	Normal: $\mu=-4.500$ ; $\sigma=1.006$
Biliary Colic	1.242 (-0.115, 2.599)	Meta analysis (7 RCTs)	Normal: $\mu=1.242$ ; $\sigma=0.692$
Cholangitis	-1.691 (-3.239, -0.143)	Meta analysis (3 RCTs)	Normal: $\mu=-1.691$ ; $\sigma=0.790$
Jaundice	-0.569 (-1.307, 0.168)	Meta analysis (8 RCTs)	Normal: $\mu=-0.569$ ; $\sigma=0.376$
Pancreatitis	-1.677 (-2.352, -1.002)	Meta analysis (6 RCTs)	Normal: $\mu=-1.677$ ; $\sigma=0.344$
Probability of CBDS Symptoms at baseline			
Sepsis	0.250 (0.055, 0.530)	GDG Assumption (a)	Beta: $\alpha=2.750$ ; $\beta=8.250$
<b>Symptoms at baseline – GS</b>			
Ln(Odds) Symptoms			
Acute Cholecystitis	-2.778 (-3.231, -2.326)	Meta analysis (2 RCTs)	Normal: $\mu=-2.778$ ; $\sigma=0.231$
Biliary Colic	-2.266 (-3.330, -1.203)	Meta analysis (3 RCTs)	Normal: $\mu=-2.266$ ; $\sigma=0.543$

Parameter	Value (95% confidence interval)	Reference	Distribution and Parameters
<b>Symptoms during delay/Conservative Management - CBDS</b>			
Ln(rate per day) Symptoms during delay			
Acute Cholecystitis	-4.990 (-6.535, -3.444)	Meta analysis (6 RCTs)	Normal: $\mu=-4.990$ ; $\sigma=0.789$
Biliary Colic	-6.647 (-9.597, -3.697)	Meta analysis (3 RCTs)	Normal: $\mu=-6.647$ ; $\sigma=1.505$
Cholangitis	-6.804 (-8.878, -4.730)	Meta analysis (8 RCTs)	Normal: $\mu=-6.804$ ; $\sigma=1.058$
Jaundice	-6.054 (-8.002, -4.107)	Meta analysis (4 RCTs)	Normal: $\mu=-6.054$ ; $\sigma=0.994$
Pancreatitis	-8.786 (-10.668, -6.904)	Meta analysis (7 RCTs)	Normal: $\mu=-8.786$ ; $\sigma=0.960$
Sepsis	-3.474 (-3.961, -2.987)	Meta analysis (4 RCTs)	Normal: $\mu=-3.474$ ; $\sigma=0.248$
<b>Symptoms during delay/Conservative Management - gallstones</b>			
Ln(rate per day) Symptoms during delay			
Acute Cholecystitis	-8.133 (-10.334, -5.932)	Meta analysis (4 RCTs)	Normal: $\mu=-8.133$ ; $\sigma=1.123$
Biliary Colic	-9.250 (-10.634, -7.866)	Meta analysis (2 RCTs)	Normal: $\mu=-9.250$ ; $\sigma=0.706$
Pancreatitis Mortality			
All pancreatitis	0.00008 (0.00003, 0.00020)	Chiang et al	Lognormal: $\mu=-9.40911$ ; $\sigma=0.44721$
Gallbladder Cancer			
Incidence rate (1 death, 873 person years)	0.0011 (0.0002, 0.0081)	Attili et al (Q3)	Lognormal: $\mu=-6.7719$ ; $\sigma=1.0000$
Mortality Rate (5 year survival 2002-2006)	0.878 (0.862, 0.894)	NW Cancer Registry	Beta: $\alpha=1410.376$ ; $\beta=195.975$
<b>Laparoscopic Cholecystectomy Consequences</b>			
Bile duct injury sustained (BDI)			
Ln(Odds) with LC	-4.503 (-5.344, -3.661)	Meta Analysis (8 RCTs)	Normal: $\mu=-4.503$ ; $\sigma=0.429$
Ln(OR) LC+IOC -v- LC	0.069 (-1.691, 1.830)	Meta Analysis (3 RCTs)	Normal: $\mu=0.069$ ; $\sigma=0.898$
Ln(OR) LC(DC) -v- LC(IP)	1.099 (-2.124, 4.322)	Johansson	Normal: $\mu=1.099$ ; $\sigma=1.644$
Ln(OR) LC(early) -v- LC	-0.043 (-1.813, 1.728)	Meta Analysis (4 RCTs)	Normal: $\mu=-0.043$ ; $\sigma=0.903$



Parameter	Value (95% confidence interval)	Reference	Distribution and Parameters
Bile leak (requires ERCP)			
Ln(Odds) with LC	-3.635 (-4.362, -2.908)	Meta Analysis (7 RCTs)	Normal: $\mu=-3.635$ ; $\sigma=0.371$
Ln(OR) Conservative Management -v- LC	0.258 (-1.264, 1.780)	Verthus et al	Normal: $\mu=0.258$ ; $\sigma=0.777$
Ln(OR) LC(early) -v- LC	0.910 (-0.374, 2.194)	Meta Analysis (6 RCTs)	Normal: $\mu=0.910$ ; $\sigma=0.655$
Extra ERCP Required			
Ln(OR) early LC -v- LC (post-ERCP)	-1.161 (-4.387, 2.064)	Reinders et al	Normal: $\mu=-1.161$ ; $\sigma=1.646$
LC Required (Conservative Management /Delay only)			
Ln(Rate per day) with Conservative Management	-6.910 (-8.813, -5.008)	Meta Analysis (5 RCTs)	Normal: $\mu=-6.910$ ; $\sigma=0.971$
LC to OC conversion			
Ln(Odds) with LC	-2.423 (-3.121, -1.725)	Meta Analysis (14 RCTs)	Normal: $\mu=-2.423$ ; $\sigma=0.356$
Ln(OR) LC+IOC -v- LC	0.895 (-2.728, 4.518)	Meta Analysis (2 RCTs)	Normal: $\mu=0.895$ ; $\sigma=1.848$
Ln(OR) Conservative Management -v- LC	-0.030 (-1.443, 1.383)	Verthus et al	Normal: $\mu=-0.030$ ; $\sigma=0.721$
Ln(OR) DC -v- IP	-0.010 (-1.672, 1.652)	Meta Analysis (3 RCTs)	Normal: $\mu=-0.010$ ; $\sigma=0.848$
Ln(OR) early LC -v- LC	-0.224 (-0.638, 0.190)	Meta Analysis (7 RCTs)	Normal: $\mu=-0.224$ ; $\sigma=0.211$
Ln(OR) early LC -v- LC (post-ERCP)	-0.735 (-2.479, 1.009)	Reinders et al	Normal: $\mu=-0.735$ ; $\sigma=0.890$
Remaining Unseen CBDS			
Ln(Odds) with LC+IOC	-1.553 (-2.602, -0.505)	Meta Analysis (3 RCTs)	Normal: $\mu=-1.553$ ; $\sigma=0.535$
Ln(Odds) early LC -v- LC (post-ERCP)	-1.609 (-4.708, 1.490)	Lo et al	Normal: $\mu=-1.609$ ; $\sigma=1.581$
LC Operative mortality			
Ln(Odds) with LC+IOC	-1.553 (-2.602, -0.505)	Meta Analysis (3 RCTs)	Normal: $\mu=-1.553$ ; $\sigma=0.535$
Ln(Odds) early LC -v- LC (post-ERCP)	-1.609 (-4.708, 1.490)	Lo et al	Normal: $\mu=-1.609$ ; $\sigma=1.581$
LC	0.0008 (0.0002, 0.0019)	Dunn et al	Beta: $\alpha=3.0000$ ; $\beta=3801.0000$

Parameter	Value (95% confidence interval)	Reference	Distribution and Parameters
<b>ERCP Consequences</b>			
Bile leak (requires ERCP)			
Ln(Odds) with Pre-ERCP	-3.900 (-4.678, -3.122)	Meta Analysis (7 RCTs)	Normal: $\mu=-3.900$ ; $\sigma=0.397$
Ln(OR) BDE -v- Pre-ERCP	0.924 (-0.256, 2.104)	Meta Analysis (5 RCTs)	Normal: $\mu=0.924$ ; $\sigma=0.602$
Ln(OR) intra-ERCP -v- pre-ERCP	-1.089 (-4.301, 2.124)	El Geide (a) et al	Normal: $\mu=-1.089$ ; $\sigma=1.639$
Ln(OR) intra-ERCP -v- BDE	-0.963 (-3.729, 1.803)	Meta Analysis (2 RCTs)	Normal: $\mu=-0.963$ ; $\sigma=1.411$
Ln(OR) post-ERCP -v- BDE	0.647 (-3.172, 4.467)	Meta Analysis (2 RCTs)	Normal: $\mu=0.647$ ; $\sigma=1.949$
Indirect Ln(OR) post-ERCP -v- Pre-ERCP	1.572 (-2.425, 5.569)	Meta Analysis (2 RCTs)	Normal: $\mu=1.572$ ; $\sigma=2.039$
Ln(OR) with Conservative Management	-0.019 (-2.817, 2.779)	Vracko et al	Normal: $\mu=-0.019$ ; $\sigma=1.428$
ERCP needed (Conservative Management Only)			
Ln(Rate per Day) with Conservative Management	-4.379 (-5.104, -3.654)	Meta Analysis (7 RCTs)	Normal: $\mu=-4.379$ ; $\sigma=0.370$
Extra ERCP Required			
Ln(Odds) with pre-ERCP	-2.595 (-3.508, -1.681)	Meta Analysis (9 RCTs)	Normal: $\mu=-2.595$ ; $\sigma=0.466$
Ln(OR) BDE -v- pre-ERCP	-0.010 (-1.945, 1.925)	Meta Analysis (6 RCTs)	Normal: $\mu=-0.010$ ; $\sigma=0.987$
Ln(OR) intra-ERCP -v- pre-ERCP	-1.956 (-4.933, 1.020)	El Geide (a) et al	Normal: $\mu=-1.956$ ; $\sigma=1.519$
Ln(OR) intra-ERCP -v- BDE	-0.484 (-2.874, 1.906)	El Geide (b) et al	Normal: $\mu=-0.484$ ; $\sigma=1.219$
Ln(OR) post-ERCP -v- BDE	0.724 (-2.098, 3.547)	El Geide (b) et al	Normal: $\mu=0.724$ ; $\sigma=1.440$
Indirect Ln(OR) post-ERCP -v- pre-ERCP	0.714 (-2.708, 4.136)	El Geide (b) et al	Normal: $\mu=0.714$ ; $\sigma=1.746$
Ln(OR) ERCP+LC -v- ERCP	-3.105 (-5.132, -1.079)	Meta Analysis (2 RCTs)	Normal: $\mu=-3.105$ ; $\sigma=1.034$
LC Required			
Ln(Rate per day) with ERCP	-4.334 (-5.365, -3.303)	Meta Analysis (6 RCTs)	Normal: $\mu=-4.334$ ; $\sigma=0.526$
Ln(IRR) Conservative Management -v- ERCP	-0.525 (-1.092, 0.043)	Meta Analysis (4 RCTs)	Normal: $\mu=-0.525$ ; $\sigma=0.290$
LC to OC Conversion			
Ln(Odds) with ERCP	-2.773 (-3.469, -2.077)	Meta Analysis (8 RCTs)	Normal: $\mu=-2.773$ ; $\sigma=0.355$
Ln(OR) BDE -v- pre-ERCP	0.591 (-0.099, 1.282)	Meta Analysis (5 RCTs)	Normal: $\mu=0.591$ ; $\sigma=0.352$

Parameter	Value (95% confidence interval)	Reference	Distribution and Parameters
Ln(OR) intra-ERCP -v- pre-ERCP	-0.203 (-1.547, 1.141)	El Geide (a) et al	Normal: $\mu=-0.203$ ; $\sigma=0.686$
Ln(OR) intra-ERCP -v- BDE	-0.318 (-1.048, 0.412)	Meta Analysis (2 RCTs)	Normal: $\mu=-0.318$ ; $\sigma=0.372$
Ln(OR) post-ERCP -v- BDE	-1.092 (-3.151, 0.968)	Meta Analysis (2 RCTs)	Normal: $\mu=-1.092$ ; $\sigma=1.051$
Indirect Ln(OR) post-ERCP -v- pre-ERCP	-0.501 (-2.960, 1.959)	Meta Analysis (2 RCTs)	Normal: $\mu=-0.501$ ; $\sigma=1.255$
Ln(OR) ERCP+LC -v- ERCP	0.510 (-0.730, 1.749)	Meta Analysis (2 RCTs)	Normal: $\mu=0.510$ ; $\sigma=0.632$
<b>New CBDS</b>			
Ln(Rate per day) with ERCP	-9.658 (-12.677, -6.638)	Meta Analysis (3 RCTs)	Normal: $\mu=-9.658$ ; $\sigma=1.541$
Ln(IRR) ERCP+LC -v- ERCP	-3.207 (-6.029, -0.384)	Lau et al	Normal: $\mu=-3.207$ ; $\sigma=1.440$
Ln(IRR) LC post ERCP delayed -v- early	-0.042 (-2.813, 2.730)	Reinders et al	Normal: $\mu=-0.042$ ; $\sigma=1.414$
<b>Remaining Unseen CBDS</b>			
Ln(Odds) with ERCP	-2.967 (-3.976, -1.958)	Meta Analysis (6 trial arms)	Normal: $\mu=-2.967$ ; $\sigma=0.515$
Ln(OR) with BDE	-0.424 (-2.547, 1.700)	Meta Analysis (3 RCTs)	Normal: $\mu=-0.424$ ; $\sigma=1.083$
Ln(OR) intra-ERCP -v- BDE	-2.168 (-5.103, 0.766)	Meta Analysis (2 RCTs)	Normal: $\mu=-2.168$ ; $\sigma=1.497$
Indirect Ln(OR) intra-ERCP -v- Pre-ERCP	-2.592 (-6.214, 1.030)	Meta Analysis (2 RCTs)	Normal: $\mu=-2.592$ ; $\sigma=1.848$
Ln(OR) with ERCP+LC	-3.431 (-6.262, -0.599)	Lau et al	Normal: $\mu=-3.431$ ; $\sigma=1.445$
Ln(OR) with Conservative Management	-0.808 (-3.095, 1.479)	Meta Analysis (2 RCTs)	Normal: $\mu=-0.808$ ; $\sigma=1.167$
<b>ERCP Operative Mortality</b>			
Ln(Odds) with ERCP (literature)	-5.356 (-5.795, -4.916)	Williams et al	Normal: $\mu=-5.356$ ; $\sigma=0.224$
<b>Costs (c)</b>			
<b>Laparoscopic Cholecystectomy</b>			
Fixed Cost	£1,708 (£1,105, £2,440)	NHS Reference Costs	Gamma: $\alpha=£25$ ; $\beta=£68$
Bed day Cost	£383 (£248, £547)	NHS Reference Costs	Gamma: $\alpha=£25$ ; $\beta=£15$
<b>Average Length of Stay</b>			
<b>Standard laparoscopic cholecystectomy</b>			
Elective	1.14 (0.76, 1.65)	NHS Reference Costs	Lognormal: $\mu=0.11$ ; $\sigma=0.20$

Parameter	Value (95% confidence interval)	Reference	Distribution and Parameters
Non-Elective	3.15 (2.10, 4.55)	NHS Reference Costs	Lognormal: $\mu=1.13$ ; $\sigma=0.20$
Complicated LC (LC to OC conversion)			
Elective	1.88 (1.25, 2.72)	NHS Reference Costs	Lognormal: $\mu=0.61$ ; $\sigma=0.20$
Non-Elective	6.03 (4.01, 8.71)	NHS Reference Costs	Lognormal: $\mu=1.78$ ; $\sigma=0.20$
LC+BDE			
Elective	3.59 (2.39, 5.19)	NHS Reference Costs	Lognormal: $\mu=1.26$ ; $\sigma=0.20$
Non-Elective	7.16 (4.76, 10.35)	NHS Reference Costs	Lognormal: $\mu=1.95$ ; $\sigma=0.20$
ERCP			
Fixed Cost	£610 (£394, £871)	NHS Reference Costs	Gamma: $\alpha=£25$ ; $\beta=£24$
Bed day Cost	£305 (£197, £435)	NHS Reference Costs	Gamma: $\alpha=£25$ ; $\beta=£12$
Average Length of Stay			
Elective	1.42 (0.81, 2.48)	NHS Reference Costs	Lognormal: $\mu=0.35$ ; $\sigma=0.28$
Non-Elective	6.11 (0.56, 67.09)	NHS Reference Costs	Lognormal: $\mu=1.81$ ; $\sigma=1.22$
Length of stay - intervention data			
Additional Length of Stay for LC+IOC	0.00 (-1.96, 1.96)	Soper et al	Normal: $\mu=0.00$ ; $\sigma=1.00$
Extra radiographer time (hours)	0.25 (0.13, 0.45)	GDG assumption	Triangular: min=0.08; mode=0.25; max=0.50
Hourly radiographer cost	£33	PSSRU (2012)	
Additional Length of Stay for Conservative Management	0.00	GDG assumption	
DC Length of Stay (RCT reported)	1.08 (1.06,1.24)	Johansson et al	Beta: $\alpha=4.00$ ; $\beta=48.00$
IP Length of Stay (RCT reported)	2.13 (2.08,2.36)	Johansson et al	Beta: $\alpha=6.00$ ; $\beta=42.00$
Additional Length of Stay for IP	1.05	Calculation	
Additional Length of Stay for pre-ERCP	0.75 (-0.88, 2.38)	Network Meta Analysis (6 RCTs)	Normal: $\mu=0.75$ ; $\sigma=0.83$
Additional Length of Stay for intra-ERCP	-0.68 (-3.21, 1.85)	Network Meta Analysis (6 RCTs)	Normal: $\mu=-0.68$ ; $\sigma=1.29$

Parameter	Value (95% confidence interval)	Reference	Distribution and Parameters
Additional Length of Stay for post-ERCP	2.53 (-1.40, 6.46)	Network Meta Analysis (6 RCTs)	Normal: $\mu=2.53$ ; $\sigma=2.01$
Additional Length of Stay for ERCP+LC	3.34 (1.66, 5.02)	Meta Analysis (2 RCTs)	Normal: $\mu=3.34$ ; $\sigma=0.86$
Additional Length of Stay for Conservative Management	0.00		
Additional Length of Stay for Delayed LC	3.07 (2.46, 3.68)	Meta Analysis (6 RCTs)	Normal: $\mu=3.07$ ; $\sigma=0.31$
Additional Length of Stay for delayed LC post ERCP	0.00 (-1.96, 1.96)	Reinders et al	Normal: $\mu=0.00$ ; $\sigma=1.00$
LC+ERCP in same admission (assume elective)			
Length of stay	5.0 (3.7, 21.6)	GDG assumption	Triangular: min=2.5; mode=5.0; max=25.0
Conservative Management			
LC Conservative Management length of stay	7.0 (5.0, 24.4)	GDG assumption	Triangular: min=3.5; mode=7.0; max=28.0
ERCP Conservative Management length of stay	7.0 (5.0, 24.4)	GDG assumption	Triangular: min=3.5; mode=7.0; max=28.0
Gallbladder Cancer			
Cost of 'best supportive care' per year (2008)	£9,963 (£6,448, £14,231)	NICE TA189	Gamma: $\alpha=£025$ ; $\beta=£399$
PSSRU inflator	1.06	PSSRU	
<b>Utilities</b>			
Utility values (raw)			
Preoperative (symptomatic)	0.742 (0.594,0.890)	Meta analysis (5 RCTs)	Lognormal: $\mu=-1.355$ ; $\sigma=0.148$ (b)
1 day (in hospital)	0.729 (0.583,0.875)	Keus et al	Lognormal: $\mu=-1.307$ ; $\sigma=0.146$ (b)
2 weeks (LC)	0.763 (0.611,0.916)	Meta analysis (2 RCTs)	Lognormal: $\mu=-1.440$ ; $\sigma=0.153$ (b)
6 weeks+ (recovered)	0.849 (0.680,1.000)	Meta analysis (3 RCTs)	Lognormal: $\mu=-1.893$ ; $\sigma=0.170$ (b)
ERCP decrement (between LC and Recovered)	0.899 (0.799,0.899)	GDG Assumption	Triangular: min=0.799; mode=0.899; max=0.899

Parameter	Value (95% confidence interval)	Reference	Distribution and Parameters
Utility decrements (multiplicative, based on length of hospital stay)			
Asymptomatic (living with stones)	0.980 (0.784,1.000)	Penniston et al	Lognormal: $\mu=-3.888$ ; $\sigma=0.196$
LC+ERCP - assumed decrement to LC	0.950 (0.869, 0.986)	GDG assumption	Triangular: min=0.850; mode=0.950; max=1.000
BDI (long term)	0.905 (0.724,1.000)	Meta analysis (2 RCTs)	Lognormal: $\mu=-2.356$ ; $\sigma=0.181$
Gallbladder Cancer	0.700 (0.560,0.840)	NICE TA189	Lognormal: $\mu=-1.204$ ; $\sigma=0.140$
Utility Population norms			
Men			
age < 25	0.94 (0.92, 0.96)	Kind et al	Beta: $\alpha=470.31$ ; $\beta=30.02$ (b)
24 < age < 35	0.93 (0.91, 0.95)	Kind et al	Beta: $\alpha=779.51$ ; $\beta=58.67$ (b)
34 < age < 45	0.91 (0.89, 0.93)	Kind et al	Beta: $\alpha=659.28$ ; $\beta=65.20$ (b)
44 < age < 55	0.84 (0.80, 0.87)	Kind et al	Beta: $\alpha=341.41$ ; $\beta=65.03$ (b)
54 < age < 65	0.78 (0.74, 0.82)	Kind et al	Beta: $\alpha=333.84$ ; $\beta=94.16$ (b)
64 < age < 75	0.78 (0.74, 0.82)	Kind et al	Beta: $\alpha=388.47$ ; $\beta=109.57$ (b)
74 < age	0.75 (0.70, 0.80)	Kind et al	Beta: $\alpha=192.97$ ; $\beta=64.32$ (b)
Women			
age < 25	0.94 (0.92, 0.96)	Kind et al	Beta: $\alpha=647.03$ ; $\beta=41.30$ (b)
24 < age < 35	0.93 (0.92, 0.94)	Kind et al	Beta: $\alpha=1137.28$ ; $\beta=85.60$ (b)
34 < age < 45	0.91 (0.89, 0.93)	Kind et al	Beta: $\alpha=1009.37$ ; $\beta=99.83$ (b)
44 < age < 55	0.85 (0.82, 0.88)	Kind et al	Beta: $\alpha=546.15$ ; $\beta=96.38$ (b)
54 < age < 65	0.81 (0.78, 0.84)	Kind et al	Beta: $\alpha=530.28$ ; $\beta=124.39$ (b)
64 < age < 75	0.78 (0.75, 0.81)	Kind et al	Beta: $\alpha=556.03$ ; $\beta=156.83$ (b)
74 < age	0.71 (0.67, 0.75)	Kind et al	Beta: $\alpha=412.39$ ; $\beta=168.44$ (b)

(a) No evidence available in included studies

(b) Monotonicity preserved between values in these categories in probabilistic analyses by using same random number seed for each

*(c) For costs, reported confidence intervals reflect the 95% confidence interval of the distribution and parameters given (that is, the range over which 95% of values are drawn in Monte-Carlo sampling). Due to distributional assumptions, the confidence interval as shown may not precisely match the confidence interval reported in the underlying data and used for the one-way sensitivity analysis.*

## 3 Results and conclusions

### 3.1 Cost effectiveness results for Review Question 4b: managing symptomatic gallbladder stones

#### 3.1.1 Laparoscopic cholecystectomy with intraoperative cholangiography versus laparoscopic cholecystectomy alone (Q4b.1)

Laparoscopic cholecystectomy with intraoperative cholangiography is more costly and produces fewer QALYs than laparoscopic cholecystectomy alone and is therefore said to be dominated (see Table 20).

The increased costs are driven by higher laparoscopic-to-open cholecystectomy conversion rates in the IOC arm than in the laparoscopic cholecystectomy alone arm, whilst the QALY differences are small over a patient lifetime.

**Table 20: Cost effectiveness results for laparoscopic cholecystectomy with intraoperative cholangiography versus laparoscopic cholecystectomy alone (Q4b.1)**

Strategy	Discounted		Incremental		ICER
	Costs	QALYs	Costs	QALYs	
Laparoscopic cholecystectomy	£2475.10	16.008			
Laparoscopic cholecystectomy with IOC	£2612.50	15.997	£137.41	-0.010	Dominated

(a) Results represent means of 1000 probabilistic model runs

One-way sensitivity analysis (see Figure 11) indicates the result is sensitive to:

- rate of bile duct injury in the intraoperative cholangiography arm
- rate of laparoscopic-to-open cholecystectomy conversion in the intraoperative cholangiography arm
- additional length of stay with intraoperative cholangiography (set to zero in the base case)
- length of stay required to perform laparoscopic cholecystectomy and ERCP in the same hospital admission (if intraoperative cholangiography finds CBDS, set to 5 days in base case)

The first 2 parameters were subject to wide confidence intervals in the clinical evidence, and were not statistically significantly different to the rates for laparoscopic cholecystectomy (see Table 19).

In probabilistic sensitivity analyses (PSA) over 1000 simulations, laparoscopic cholecystectomy alone has a 67.4% chance of being cost effective at a threshold of £20,000 per QALY (see Figure 12). This remains fairly constant over a range of cost-per-QALY thresholds (see Figure 13).



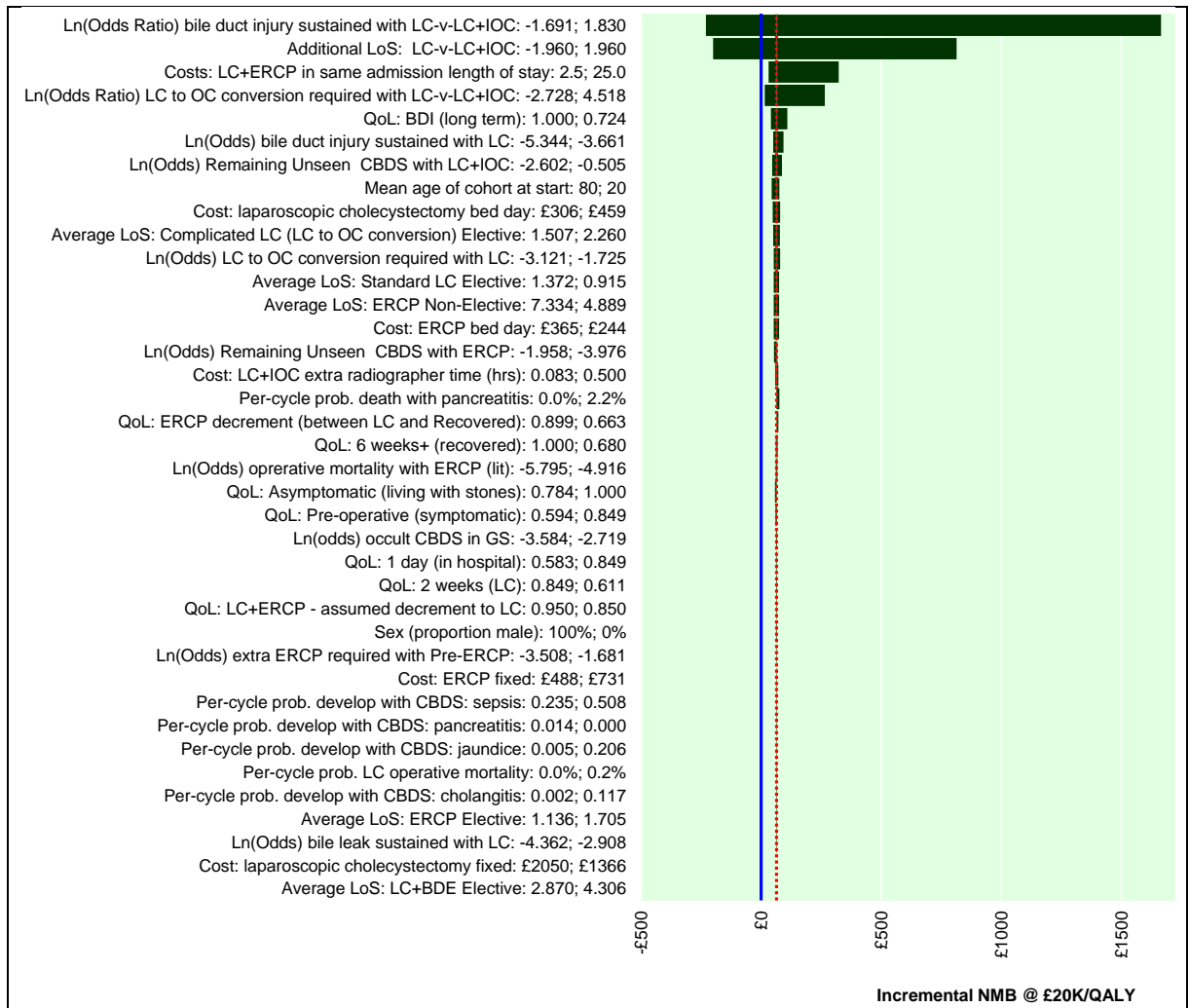

1 **Figure 11: Tornado plot of one-way sensitivity analysis for laparoscopic**  
 2 **cholecystectomy with intraoperative cholangiography versus laparoscopic**  
 3 **cholecystectomy alone**  
 4

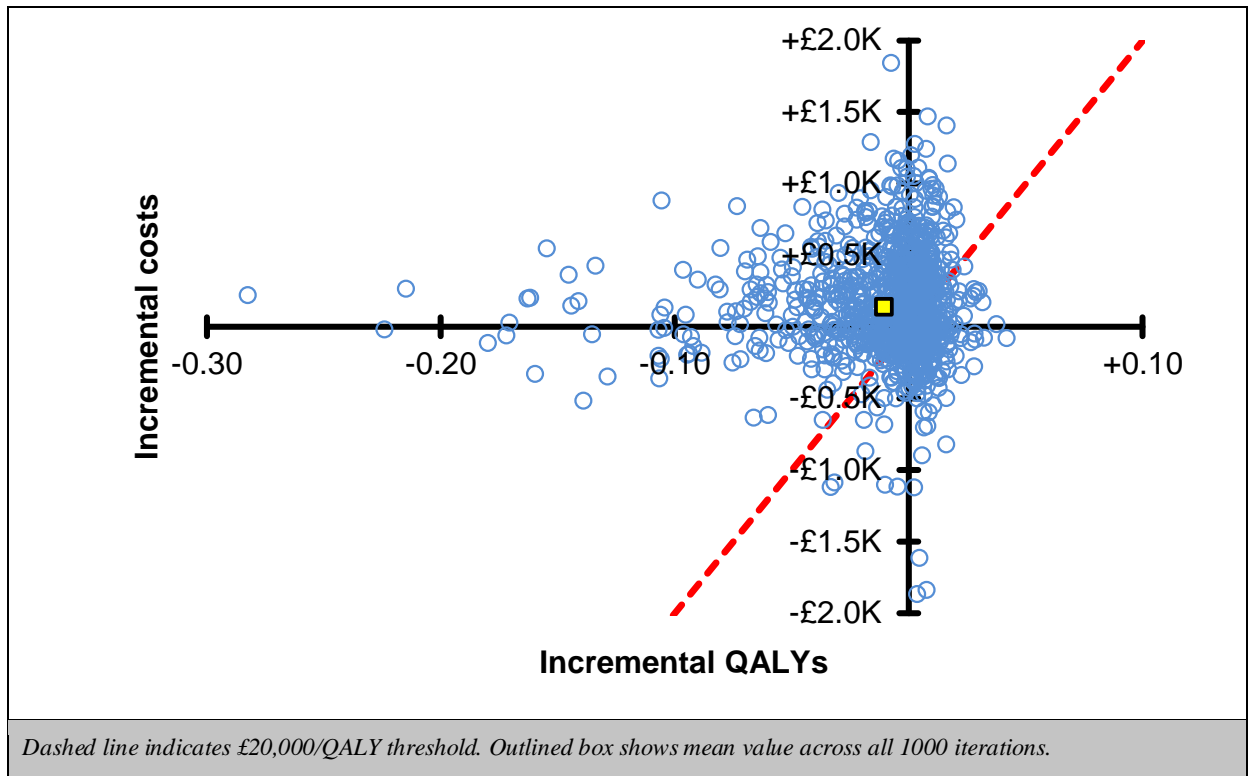

1 **Figure 12: Scatter plot of incremental costs and QALYs for laparoscopic**  
 2 **cholecystectomy with intraoperative cholangiography versus laparoscopic**  
 3 **cholecystectomy alone**  
 4

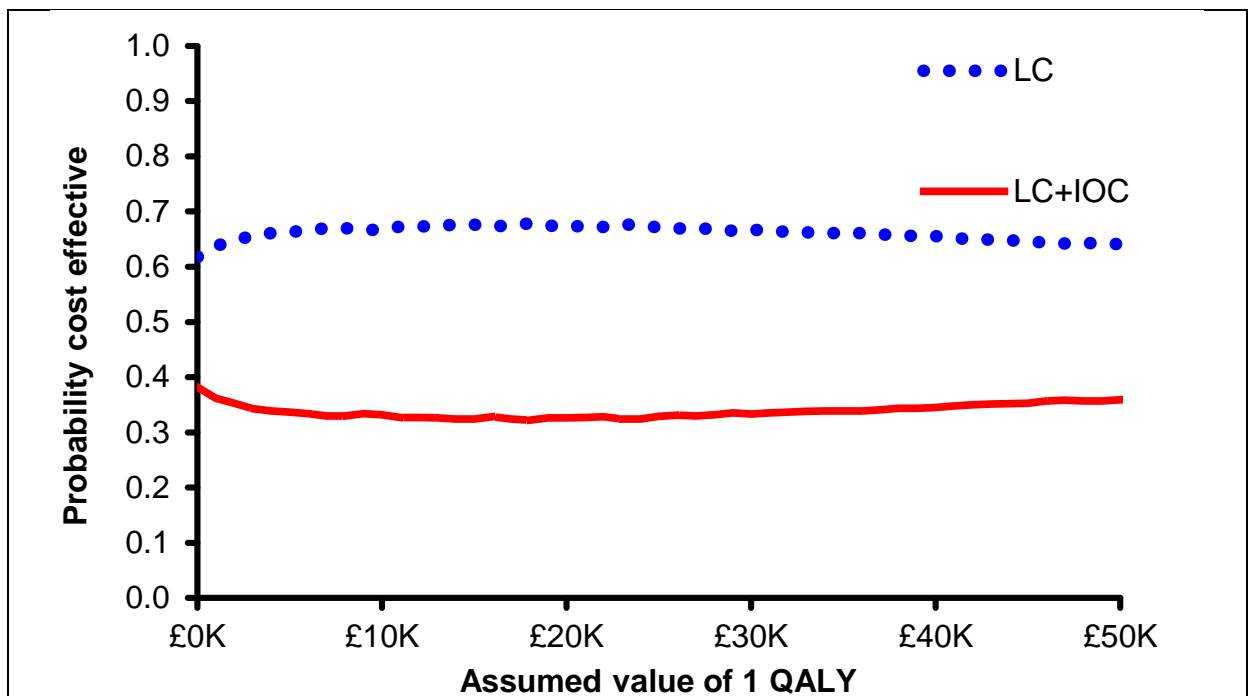

5 **Figure 13: Cost effectiveness acceptability curve for laparoscopic cholecystectomy**  
 6 **with intraoperative cholangiography versus laparoscopic cholecystectomy**  
 7 **alone**  
 8  
 9

### 3.1.12 Laparoscopic cholecystectomy versus conservative management (Q4b.2)

2 Conservative management is more costly and produces fewer QALYs than laparoscopic  
3 cholecystectomy and is therefore said to be dominated (see Table 21).

4 In the conservative management arm, patients spend most of their lives without having their  
5 gallbladder removed – 93% of which is spent in the asymptomatic gallstones or gallstones  
6 and CBDS states. If symptomatic CBDS occur, patients receive on average 0.75 additional  
7 ERCPs. It appears that not removing the gallbladder increases the need for and exposure to  
8 further ERCPs and also gallbladder cancer. Modelled differences are likely to be  
9 exaggerated because the model considers a binary choice between laparoscopic  
10 cholecystectomy and conservative management that is unlikely to occur in clinical practice.

11 **Table 21: Cost effectiveness results for laparoscopic cholecystectomy versus**  
12 **conservative management (Q4b.2)**

Strategy	Discounted		Incremental		ICER
	Costs	QALYs	Costs	QALYs	
Laparoscopic cholecystectomy	£2516.33	16.009			
Conservative Management	£11,028.41	15.323	£8512.07	-0.686	Dominated

13 (a) Results represent means of 1000 probabilistic model runs

14 One-way sensitivity analysis (see Figure 14) indicates that the result is sensitive to:

- 15 • Quality of life decrement for living with asymptomatic gallstones or gallstones and CBDS
- 16 • Gallbladder cancer incidence
- 17 • Mean age at start of model

18 It can be seen that the model is sensitive to parameters linked to leaving the gallbladder in  
19 situ for a number of years. However, it should be noted that there are no cases where  
20 laparoscopic cholecystectomy is not cost effective compared with conservative management.  
21 Laparoscopic cholecystectomy gains more QALYs than conservative management in all  
22 simulations and is less costly in 99.5% of simulations (see Figure 15). In probabilistic  
23 sensitivity analyses (PSA), over 1000 simulations laparoscopic cholecystectomy has a 100%  
24 chance of being cost effective at a threshold of £20,000 per QALY and all other thresholds  
25 tested (see Figure 16).

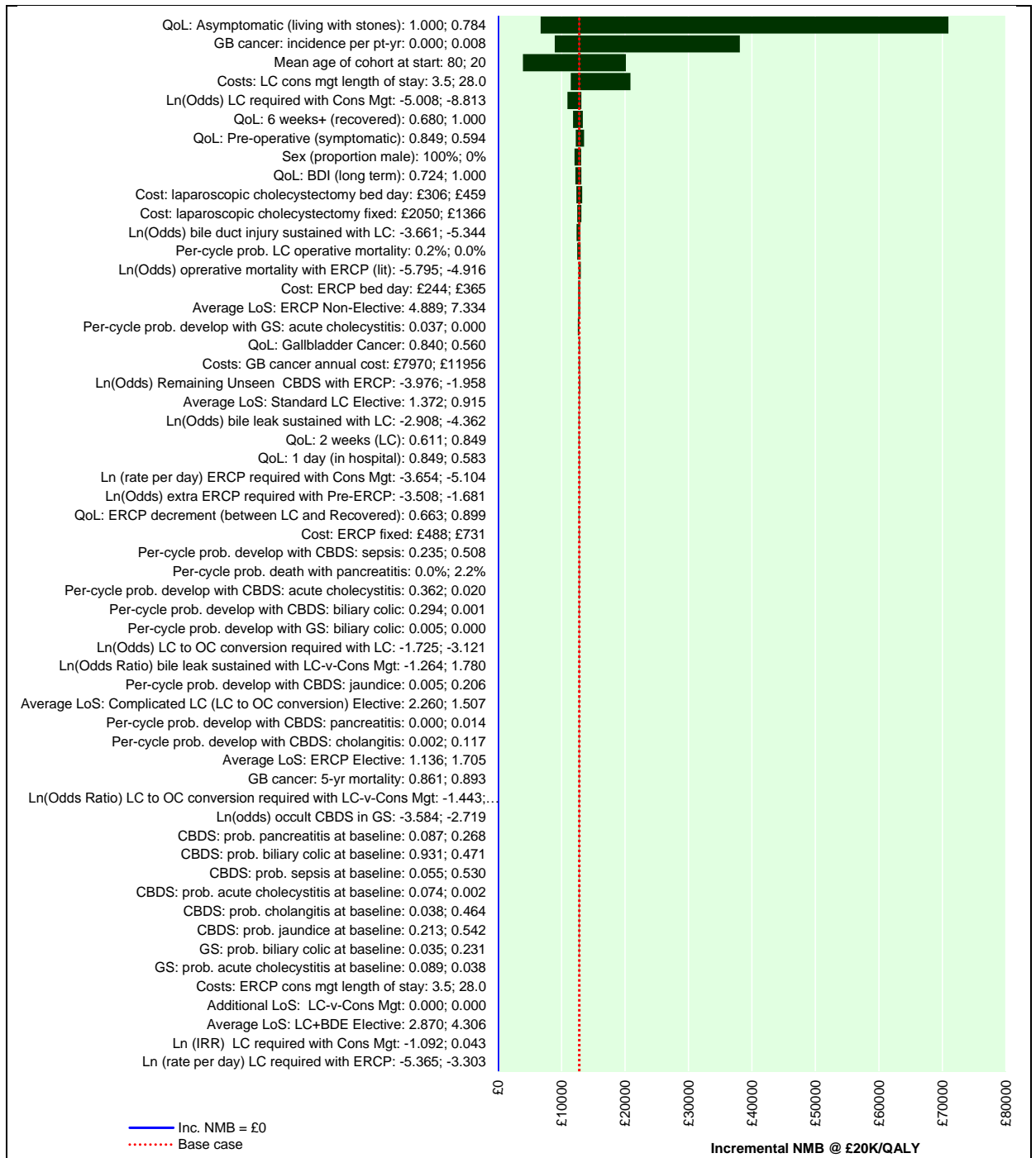

1 **Figure 14: Tornado plot of one-way sensitivity analysis for laparoscopic**  
 2 **cholecystectomy versus conservative management**  
 3

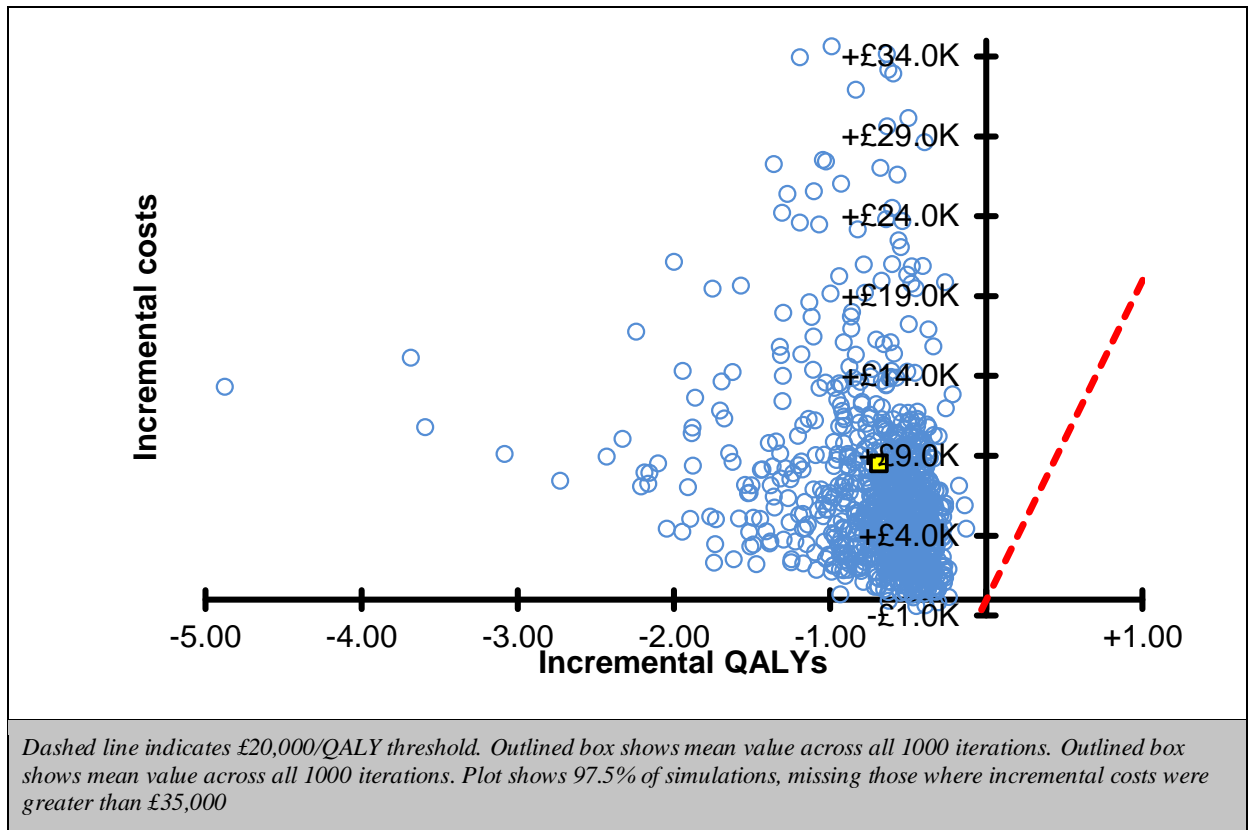

1 **Figure 15: Scatter plot of incremental costs and QALYs for laparoscopic**  
 2 **cholecystectomy versus conservative management**  
 3

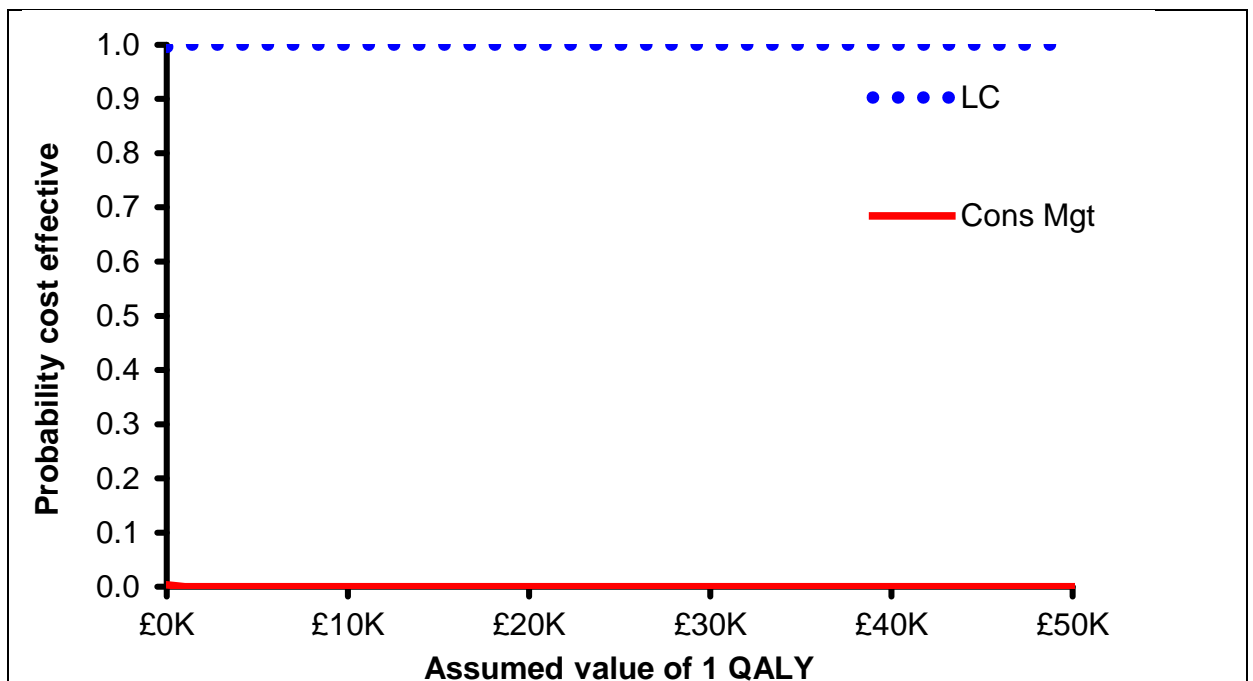

4 **Figure 16: Cost effectiveness acceptability curve for laparoscopic cholecystectomy**  
 5 **versus conservative management**  
 6  
 7

### 3.113 Day-case versus inpatient laparoscopic cholecystectomy (Q4b.3)

2 Inpatient laparoscopic cholecystectomy is more costly and produces more QALYs than day-  
3 case LC, at an acceptable cost per QALY of £3568/QALY (see Table 22).

4 The increased costs are driven by the additional length of stay in the inpatient arm. The  
5 QALY gains are driven by the worse bile duct injury rate in the day-case arm. However, this  
6 rate should be interpreted with caution as it is based on 1 RCT with 1 bile duct injury in the  
7 day-case arm and 0 events in the inpatient arm (Johansson et al. 2006) and zero event data  
8 cannot be meaningfully analysed. Hence, a 0.5 continuity correction has been added during  
9 the meta-analysis calculation. It may be more appropriate to view the QALYs as equal and  
10 inpatient laparoscopic cholecystectomy as more expensive than day-case laparoscopic  
11 cholecystectomy with comparable outcomes.

12 **Table 22: Cost effectiveness results for day-case laparoscopic cholecystectomy**  
13 **versus inpatient laparoscopic cholecystectomy (Q4b.3)**

Strategy	Discounted		Incremental		ICER
	Costs	QALYs	Costs	QALYs	
Day-case laparoscopic cholecystectomy	£2534.65	15.887			
Inpatient laparoscopic cholecystectomy	£2932.24	15.998	£397.59	0.111	£3568 / QALY

14 (a) Results represent means of 1000 probabilistic model runs

15 One-way sensitivity analysis (see Figure 17) indicates the result is sensitive to:

- 16 • Odds and odds ratio of bile duct injury in both arms and
- 17 • Mean age at the start of model

18 Under the current analysis, inpatient laparoscopic cholecystectomy is more costly than day-  
19 case laparoscopic cholecystectomy in all simulations and produces more QALYs in 73% of  
20 simulation (see Figure 18). In probabilistic sensitivity analyses over 1000 simulations,  
21 inpatient laparoscopic cholecystectomy has a 56.4% chance of being cost effective at a  
22 threshold of £20,000 per QALY compared with day-case laparoscopic cholecystectomy (see  
23 Figure 19).

24 These sensitivity analyses support a conclusion that the choice between day-case and  
25 inpatient laparoscopic cholecystectomy can be driven by their respective costs.

26

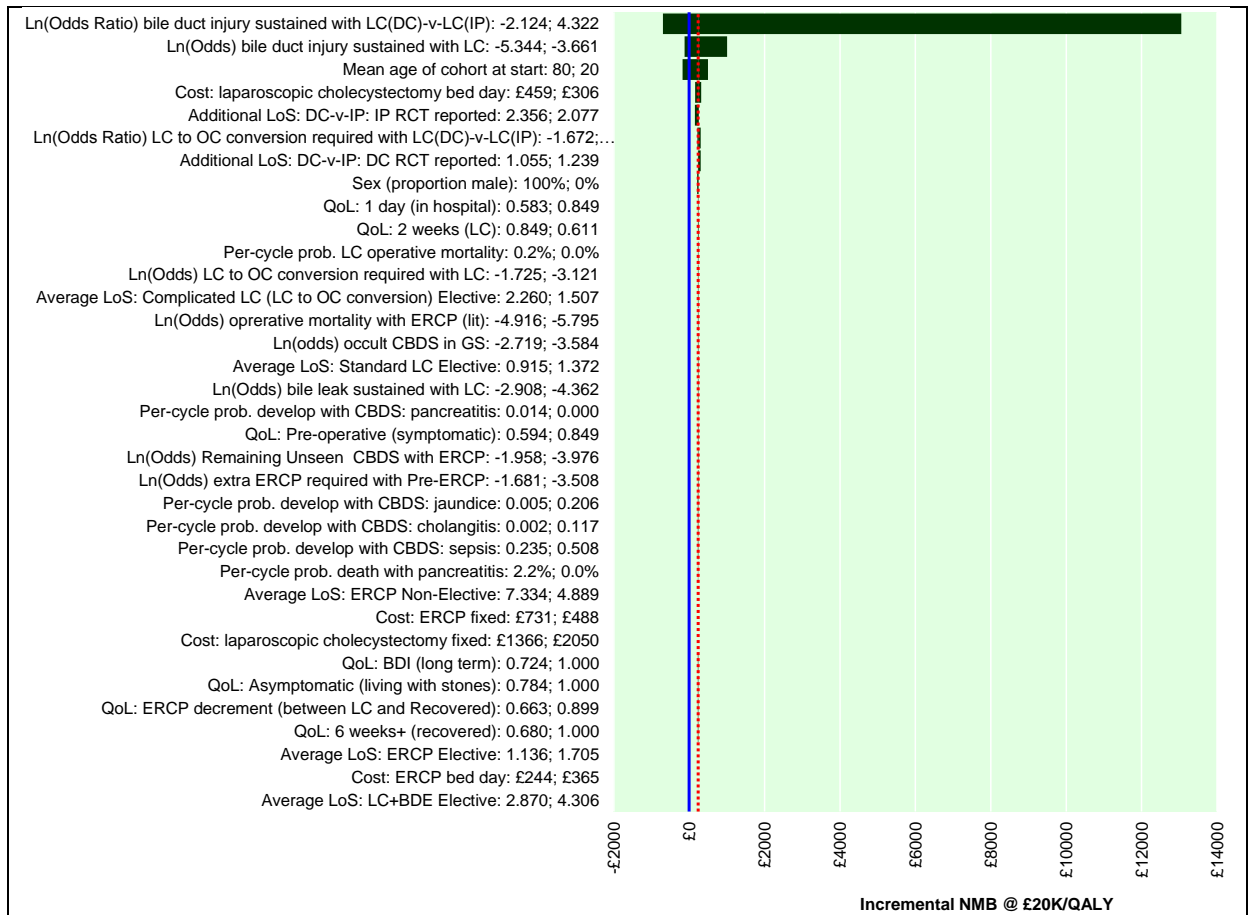

1 **Figure 17: Tornado plot of one-way sensitivity analysis for day-case versus inpatient**  
 2 **laparoscopic cholecystectomy**  
 3

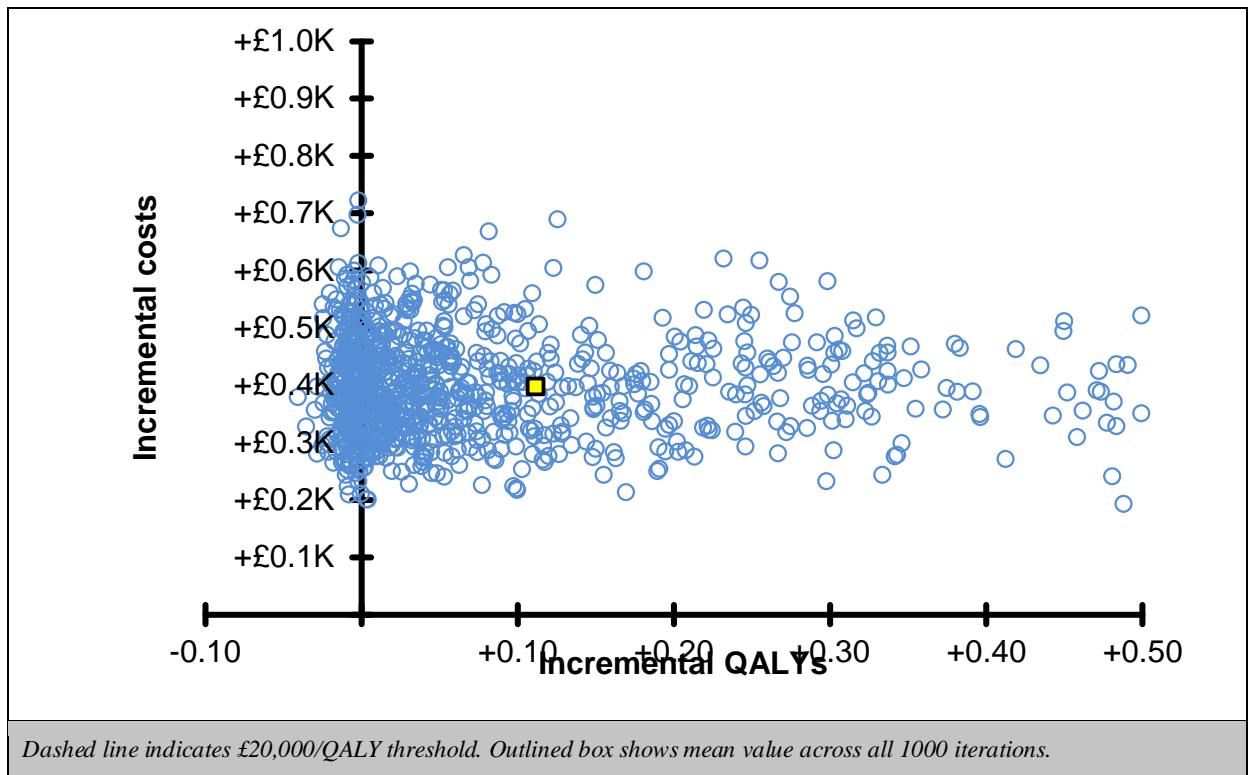

4

1 **Figure 18: Scatter plot of incremental costs and QALYs for day-case versus inpatient**  
2 **laparoscopic cholecystectomy**  
3

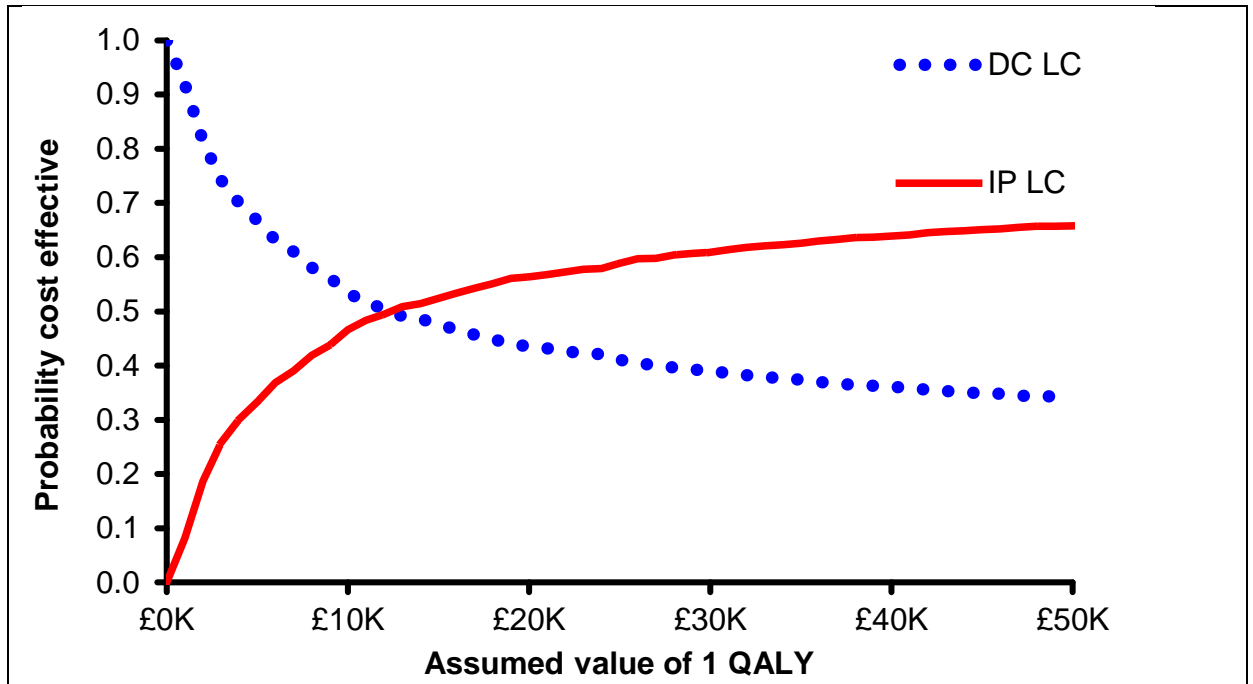

4 **Figure 19: Cost effectiveness acceptability curve for day-case versus inpatient**  
5 **laparoscopic cholecystectomy**  
6  
7



## 3.2 Cost effectiveness results for Review Question 4c: managing common bile duct stones

### 3.231 Laparoscopic cholecystectomy with bile duct exploration versus laparoscopic cholecystectomy with pre-, intra- or postoperative ERCP (Q4c.1)

In an incremental analysis of the 4 options for managing CBDS with laparoscopic cholecystectomy, laparoscopic cholecystectomy with intraoperative ERCP was less costly and produced more QALYs than either laparoscopic cholecystectomy with bile duct exploration, laparoscopic cholecystectomy with preoperative ERCP or laparoscopic cholecystectomy with postoperative ERCP. Therefore, laparoscopic cholecystectomy with intraoperative ERCP is the dominant option (see Table 23).

Pre- and postoperative ERCP options have increased costs due to requiring 2 hospital admissions. The increased costs of bile duct exploration over intraoperative ERCP are driven by higher estimated rates of bile leaks and extra ERCPs required to clear the CBDS (both outcomes are worse for bile duct exploration). However, the QALY differences are small and the evidence on intraoperative ERCP is limited to 1 or 2 RCTs.

Also, this analysis does not take account of any implementation costs that may be required to facilitate intraoperative ERCP or bile duct exploration; such as the costs of needing and co-ordinating the lists of two consultants (surgeon and radiographer).

In PSA over 1000 replications, laparoscopic cholecystectomy with intraoperative ERCP is cost effective in 86.2% of replications, compared with other options (see Table 24 and Figure 20).

**Table 23: Cost effectiveness results for laparoscopic cholecystectomy with bile duct exploration versus laparoscopic cholecystectomy with pre-, intra- or postoperative ERCP (Q4c.1)**

Strategy	Discounted		Incremental		ICER
	Costs	QALYs	Costs	QALYs	
LC with intraoperative ERCP	£3013.21	15.941			
LC with bile duct exploration	£3672.46	15.930	£659.24	-0.011	Dominated
LC with preoperative ERCP	£4124.08	15.919	£1110.87	-0.022	Dominated
LC with postoperative ERCP	£8712.44	15.896	£5699.23	-0.045	Dominated

(a) Results represent means of 1000 probabilistic model runs

**Table 24: Probabilistic sensitivity analysis results**

Strategy	Replications Cost Effective at £20,000 / QALY Threshold
Laparoscopic cholecystectomy with intraoperative ERCP	84.6%
Laparoscopic cholecystectomy with bile duct exploration	13.5%
Laparoscopic cholecystectomy with preoperative ERCP	1.9%
Laparoscopic cholecystectomy with postoperative ERCP	0.0%

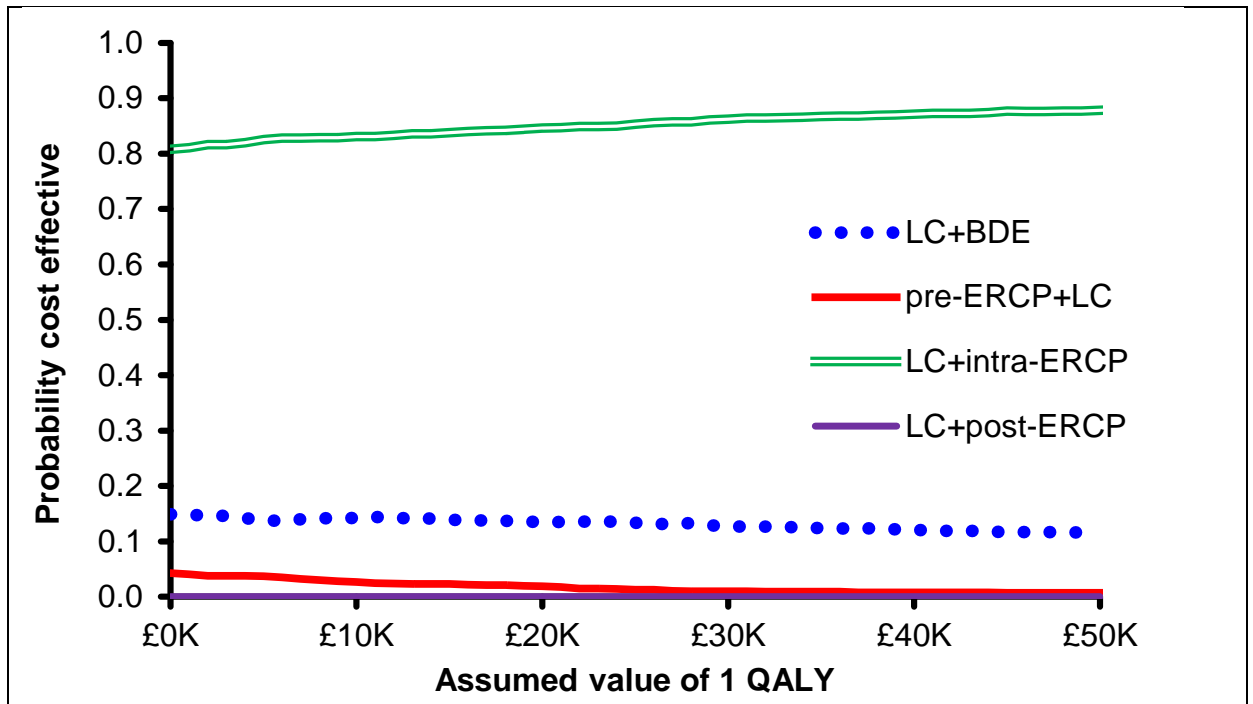

1 **Figure 20: Cost effectiveness acceptability curve for laparoscopic cholecystectomy**  
 2 **with bile duct exploration versus laparoscopic cholecystectomy with pre-,**  
 3 **intra- or postoperative ERCP**  
 4  
 5

### 3.2.12 ERCP and laparoscopic cholecystectomy versus ERCP alone (Q4c.2)

2 ERCP and laparoscopic cholecystectomy is more costly and produces more QALYs than  
3 ERCP alone, at an acceptable cost per QALY of £4680/QALY (see Table 25).

4 The increased costs are driven by all patients having a laparoscopic cholecystectomy in the  
5 ERCP and laparoscopic cholecystectomy arm. Whilst 96% of patients in the ERCP alone  
6 eventually receive a laparoscopic cholecystectomy (due to acute symptoms), these occur  
7 over a number of years and their costs are discounted. The increased QALYs are due to  
8 patients in the ERCP alone arm remaining in asymptomatic and symptomatic states.

9 **Table 25: Cost effectiveness results for ERCP and laparoscopic cholecystectomy**  
10 **versus ERCP alone (Q4c.2)**

Strategy	Discounted		Incremental		ICER
	Costs	QALYs	Costs	QALYs	
ERCP alone	£1873.52	15.919			
ERCP and laparoscopic cholecystectomy	£2310.48	16.012	£436.96	0.093	£4680 / QALY

11 (a) Results represent means of 1000 probabilistic model runs

12 One-way sensitivity analysis (see Figure 21) indicates the result is sensitive to:

- 13 • Quality of life decrement for living with asymptomatic gallstones or gallstones and CBDS
- 14 • Mean age at start of model
- 15 • Probabilities of developing acute cholecystitis and biliary colic symptoms

16 Like in conservative management arms (see 3.1.2 and 3.2.3), the model is sensitive to  
17 parameters associated with leaving the gallbladder in situ.

18 In PSA, ERCP with laparoscopic cholecystectomy is more costly than ERCP alone in 95% of  
19 simulations and produces more QALYs in 99.8% of simulation (see Figure 22). Over 1,000  
20 simulations, ERCP with laparoscopic cholecystectomy has a 98.5% chance of being cost  
21 effective at a threshold of £20,000 per QALY compared with ERCP alone (see Figure 23).  
22

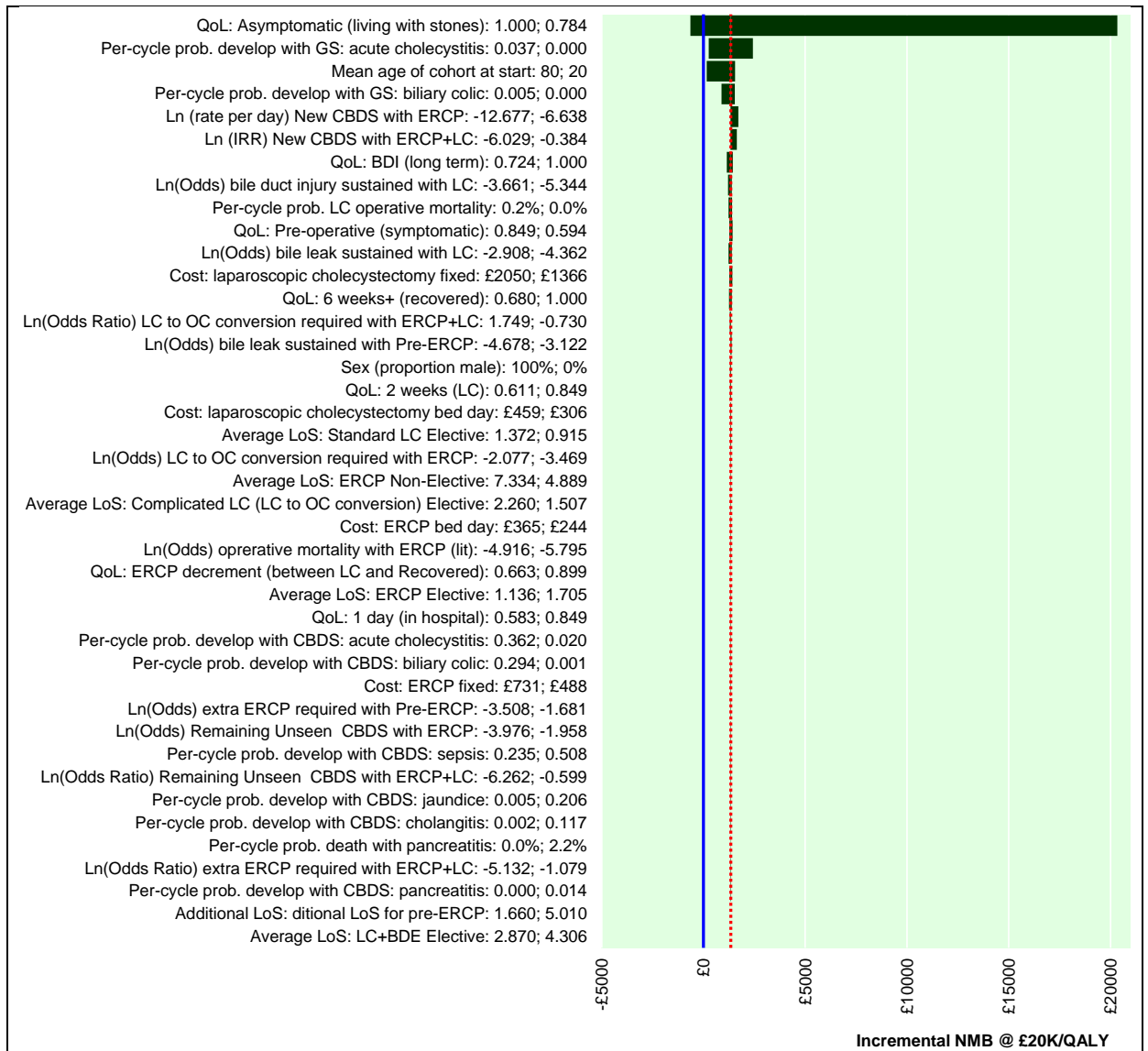

1 **Figure 21: Tornado plot of one-way sensitivity analysis for ERCP and laparoscopic**  
 2 **cholecystectomy versus ERCP alone**  
 3

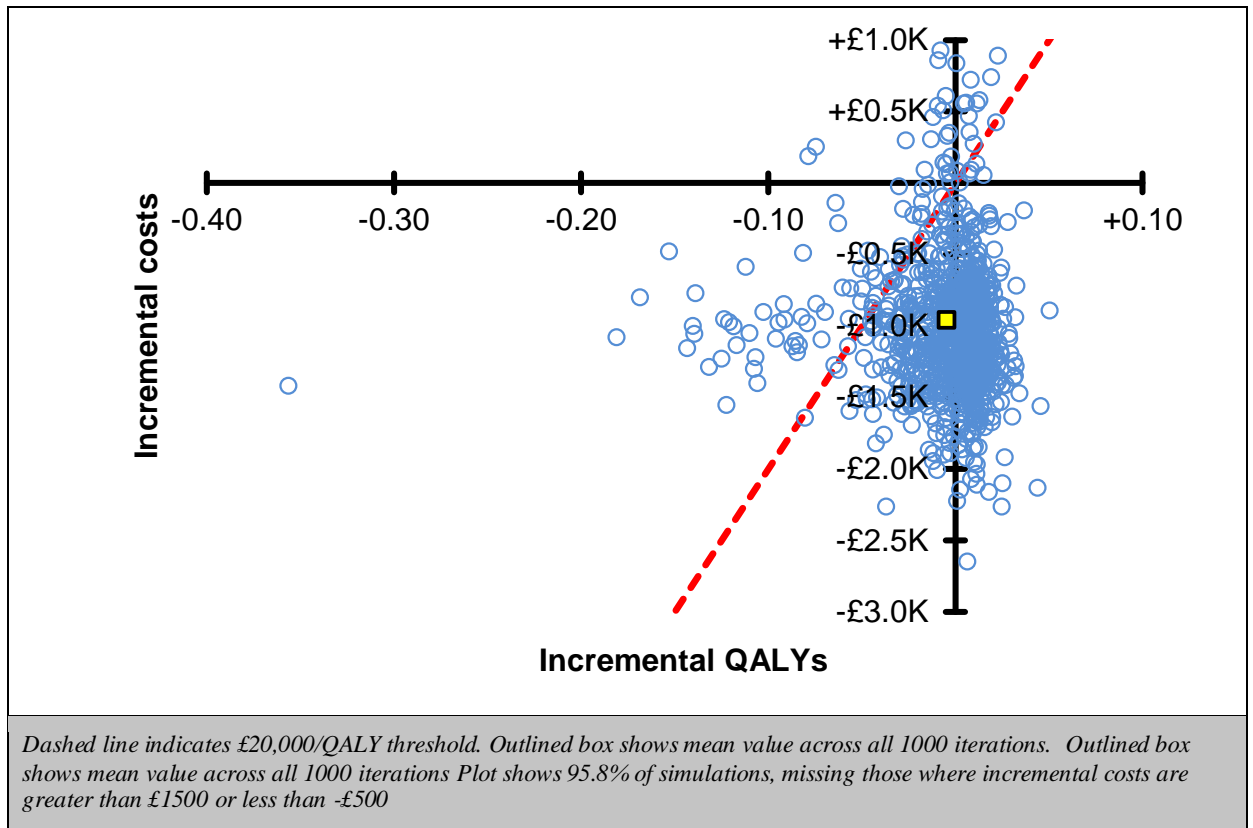

1 **Figure 22: Scatter plot of incremental costs and QALYs for ERCP with laparoscopic**  
 2 **cholecystectomy versus ERCP alone**  
 3

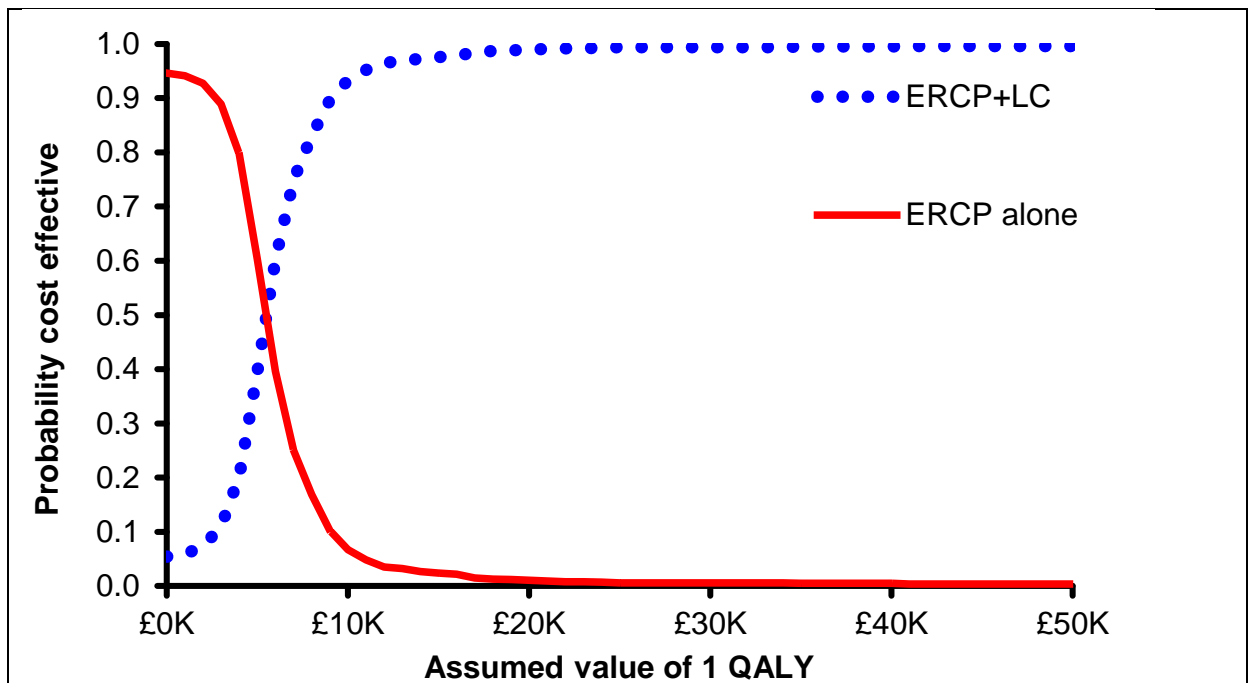

4 **Figure 23: Cost effectiveness acceptability curve for ERCP with laparoscopic**  
 5 **cholecystectomy versus ERCP alone**

6  
7

### 3.2.13 ERCP versus conservative management (Q4c.3)

2 Conservative management is more costly and produces fewer QALYs than ERCP and is  
3 therefore said to be dominated (see Table 26).

4 In the conservative management arm, patients spend most of the lives in the gallstones or  
5 gallstones and CBDS states and receive on average 1.1 additional ERCs. The increased  
6 costs are also driven by the ERCs in the conservative management arm being non-elective,  
7 rather than elective in the ERCP arm. The decreased QALYs in the conservative arm are  
8 due to patients remaining in asymptomatic or symptomatic states. Modelled differences are  
9 likely to be exaggerated because the model considers a binary choice between laparoscopic  
10 cholecystectomy and conservative management that is unlikely to occur in clinical practice.

11 **Table 26: Cost effectiveness results for ERCP versus conservative management**  
12 **(Q4c.3)**

Strategy	Discounted		Incremental		ICER
	Costs	QALYs	Costs	QALYs	
ERCP	£3366.72	15.923			
Conservative management	£11,437.11	15.476	£8070.39	-0.446	Dominated

13 (a) Results represent means of 1000 probabilistic model runs

14 One-way sensitivity analysis (see Figure 24) indicates that the result is sensitive to:

- 15 • Quality of life decrement for living with asymptomatic gallstones or gallstones and CBDS
- 16 • Gallbladder cancer incidence
- 17 • Rate of new CBDS occurring
- 18 • Mean age at start of model

19 It can be seen that the model is sensitive to parameters linked to leaving the gallbladder in  
20 situ for a number of years. However, it should be noted that there are no cases where  
21 laparoscopic cholecystectomy is not cost effective compared with conservative management.

22 In PSA, ERCP alone gains more QALYs than conservative management in all simulations  
23 and is less costly in 99.6% of simulations (see Figure 25). Over 1000 simulations, ERCP  
24 alone has a 100% chance of being cost effective at a threshold of £20,000 per QALY  
25 compared to conservative management (see Figure 26).

26

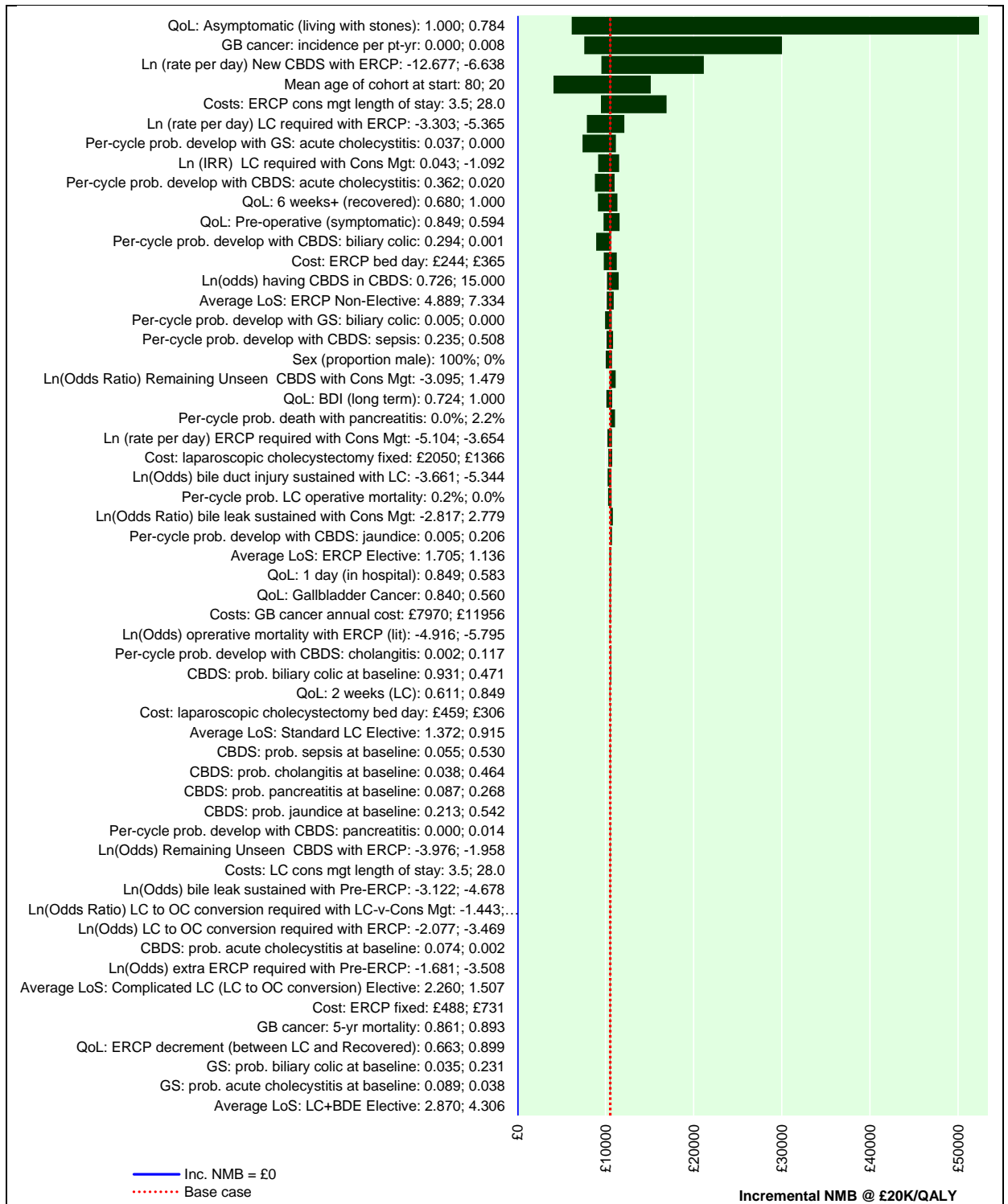

1 **Figure 24: Tornado plot of one-way sensitivity analysis for ERCP versus conservative**  
 2 **management**  
 3

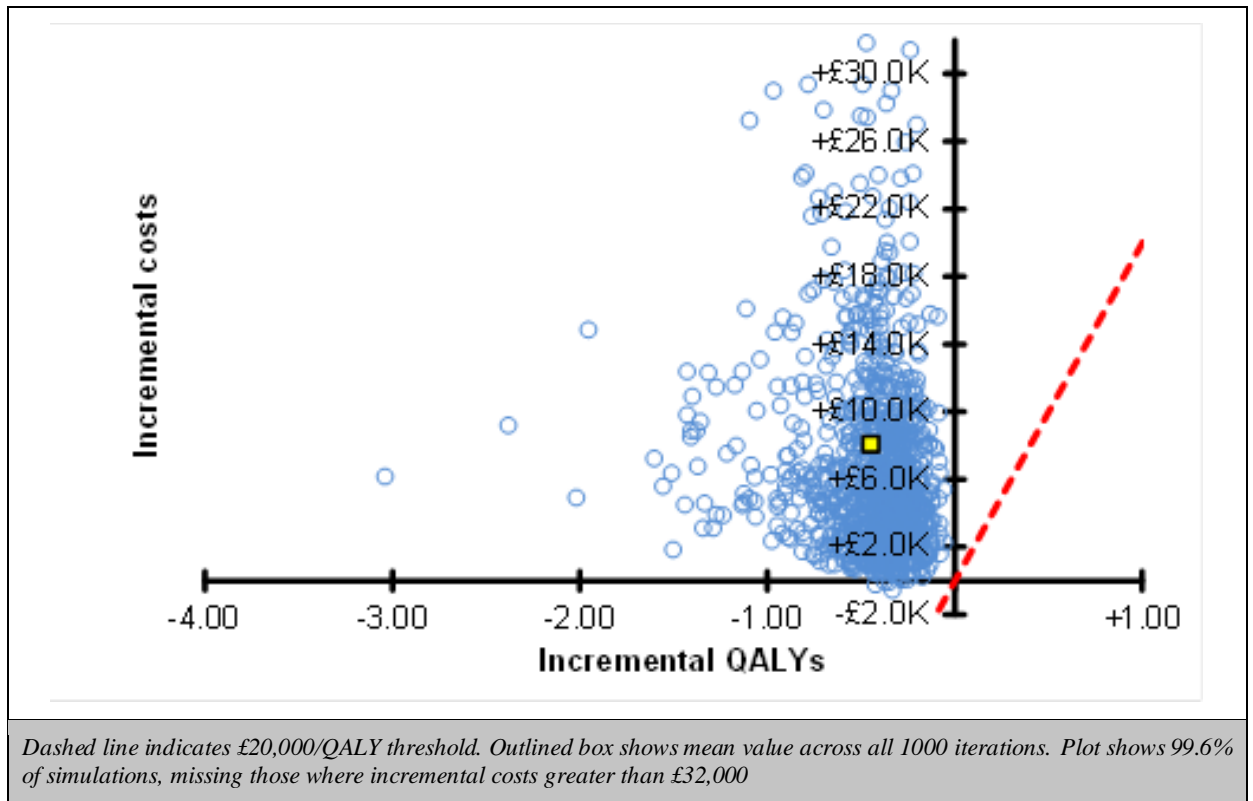

1 **Figure 25: Scatter plot of incremental costs and QALYs for ERCP versus conservative**  
 2 **management**  
 3

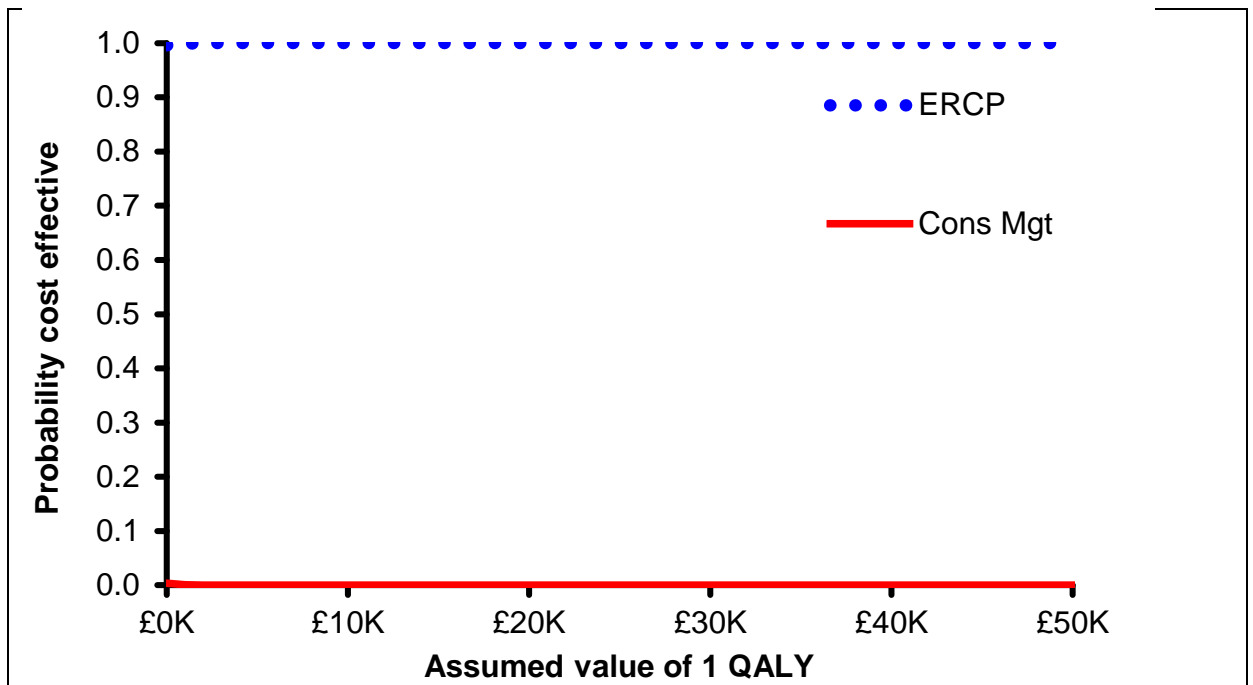

4 **Figure 26: Cost effectiveness acceptability curve for ERCP versus conservative**  
 5 **management**  
 6



### 3.3 Cost effectiveness results for Review Question 5: timing of laparoscopic cholecystectomy

2

#### 3.3.1 Early versus delayed laparoscopic cholecystectomy (Q5a.1)

4 Delayed laparoscopic cholecystectomy is more costly and produces more QALYs than early  
5 laparoscopic cholecystectomy, but an ICER of over £200,000/QALY is above that which is  
6 usually accepted as being cost effective (see Table 27).

7 The increased costs are driven by the additional length of stay associated with delayed  
8 laparoscopic cholecystectomy; the QALY differences are small.

9 **Table 27: Cost effectiveness results for early laparoscopic cholecystectomy versus**  
10 **delayed laparoscopic cholecystectomy (Q5a.1)**

Strategy	Discounted		Incremental		ICER
	Costs	QALYs	Costs	QALYs	
Early laparoscopic cholecystectomy	£2728.27	15.983			
Delayed laparoscopic cholecystectomy	£3686.21	15.988	£957.94	0.005	£201,896 / QALY

11 (a) Results represent means of 1000 probabilistic model runs

12 One-way sensitivity analysis (see Figure 27) indicates that the result is sensitive to:

- 13 • Rates of bile duct injury and bile leak in the delayed laparoscopic cholecystectomy arm
- 14 • Costs and length of stay associated with delayed laparoscopic cholecystectomy
- 15 • Quality of life decrements associated with delayed laparoscopic cholecystectomy

16 Only the bile duct injury rate would make delayed laparoscopic cholecystectomy cost  
17 effective compared with early laparoscopic cholecystectomy. This is a statistically non-  
18 significant parameter with zero events in 6 of the 8 arms compared and therefore should be  
19 interpreted with caution.

20 In PSA, delayed laparoscopic cholecystectomy is more costly than early laparoscopic  
21 cholecystectomy in 94.3% of simulations and produces more QALYs in 42.8% of simulations  
22 (see Figure 28). Over 1000 simulations, early laparoscopic cholecystectomy has an 88.2%  
23 chance of being cost effective at a threshold of £20,000 per QALY compared with delayed  
24 laparoscopic cholecystectomy (see Figure 29).

25

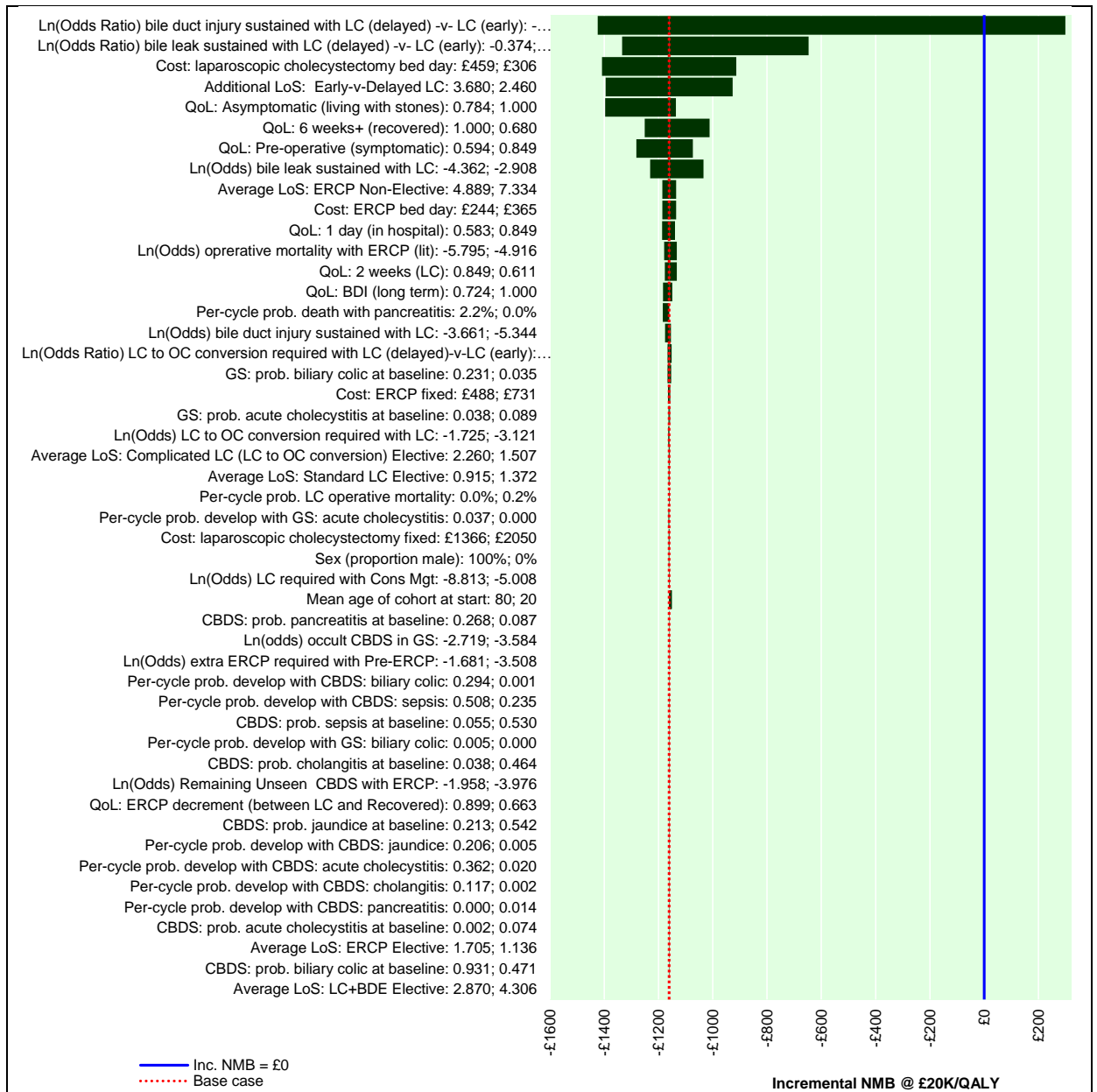

1 **Figure 27: Tornado plot of one-way sensitivity analysis for early versus delayed**  
 2 **laparoscopic cholecystectomy**  
 3

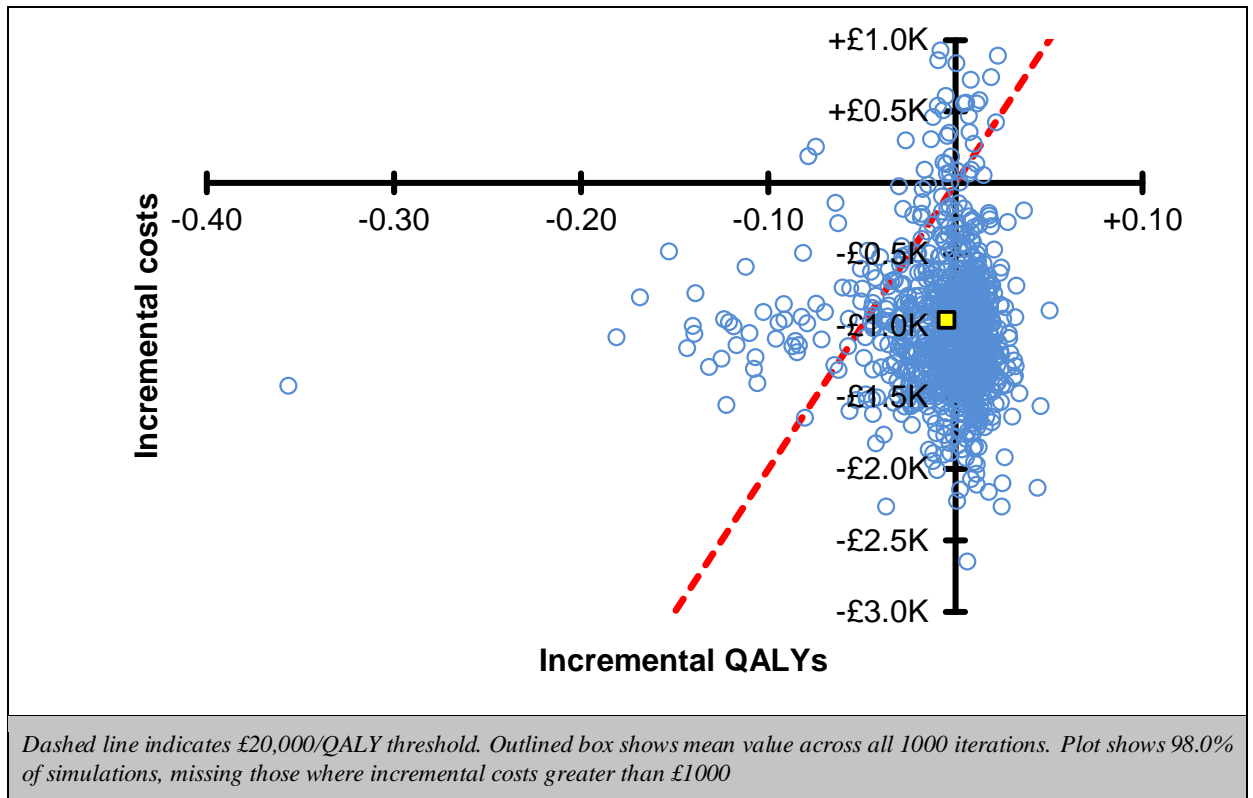

1 **Figure 28: Scatter plot of incremental costs and QALYs for early versus delayed**  
 2 **laparoscopic cholecystectomy**  
 3

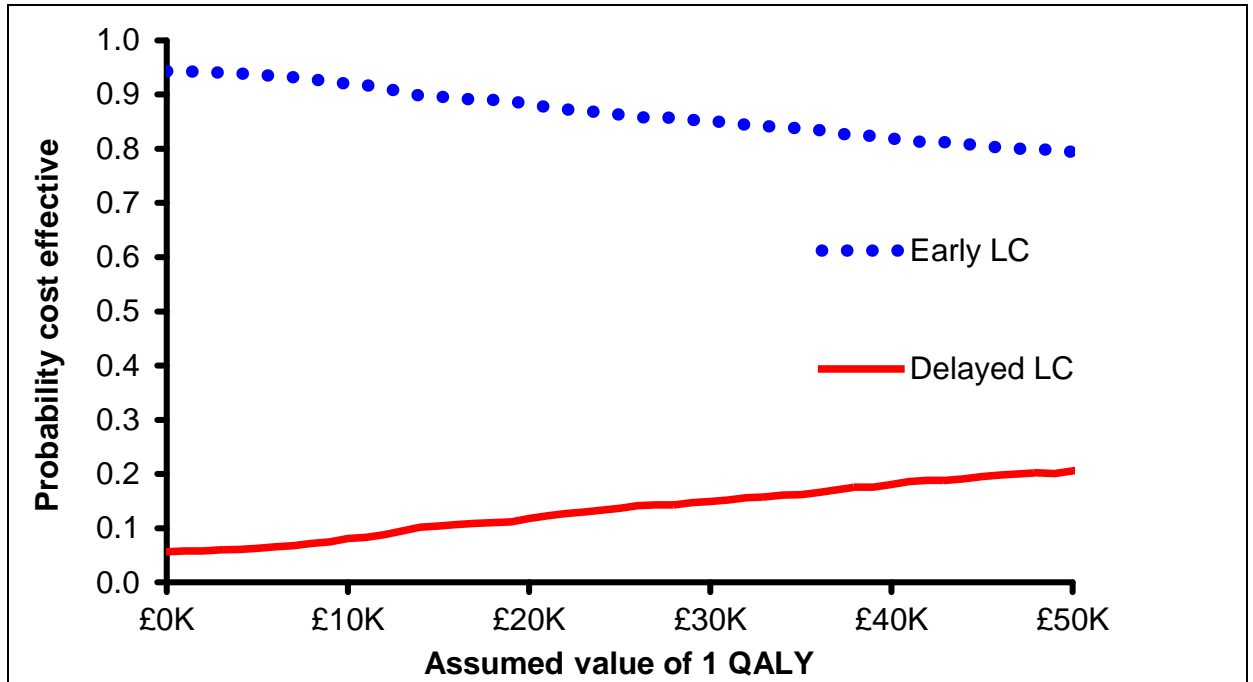

4 **Figure 29: Cost effectiveness acceptability curve for early versus delayed**  
 5 **laparoscopic cholecystectomy**  
 6

### 3.3.2 Early versus delayed laparoscopic cholecystectomy following ERCP (Q5a.2)

2 Delayed laparoscopic cholecystectomy following ERCP is more costly and produces fewer  
3 QALYs than early laparoscopic cholecystectomy following ERCP and is therefore said to be  
4 dominated (see Table 28).

5 Again, the increased costs are driven by the additional length of stay associated with delayed  
6 laparoscopic cholecystectomy; the QALY differences are small.

7 **Table 28: Cost effectiveness results for early laparoscopic cholecystectomy following**  
8 **ERCP versus delayed laparoscopic cholecystectomy following ERCP (Q5a.2)**

Strategy	Discounted		Incremental		ICER
	Costs	QALYs	Costs	QALYs	
Early LC following ERCP	£2322.14	16.007			
Delayed LC following ERCP	£2402.21	16.002	£80.06	-0.005	Dominated

9 (b) Results represent means of 1000 probabilistic model runs

10 One-way sensitivity analysis (see Figure 30) indicates that the result is sensitive to:

- 11 • Quality of life decrement for living with asymptomatic gallstones or gallstones and CBDS
- 12 • Rate and rate ratio of new CBDS occurring

13 In PSA, delayed laparoscopic cholecystectomy following ERCP is more costly than early  
14 laparoscopic cholecystectomy following ERCP in 99.6% of simulations and produces less  
15 QALYs in all simulations (see Figure 31). Over 1000 simulations, early laparoscopic  
16 cholecystectomy following ERCP has a 100% chance of being cost effective at a threshold of  
17 £20,000 per QALY compared with delayed laparoscopic cholecystectomy following ERCP  
18 (see Figure 32).

19

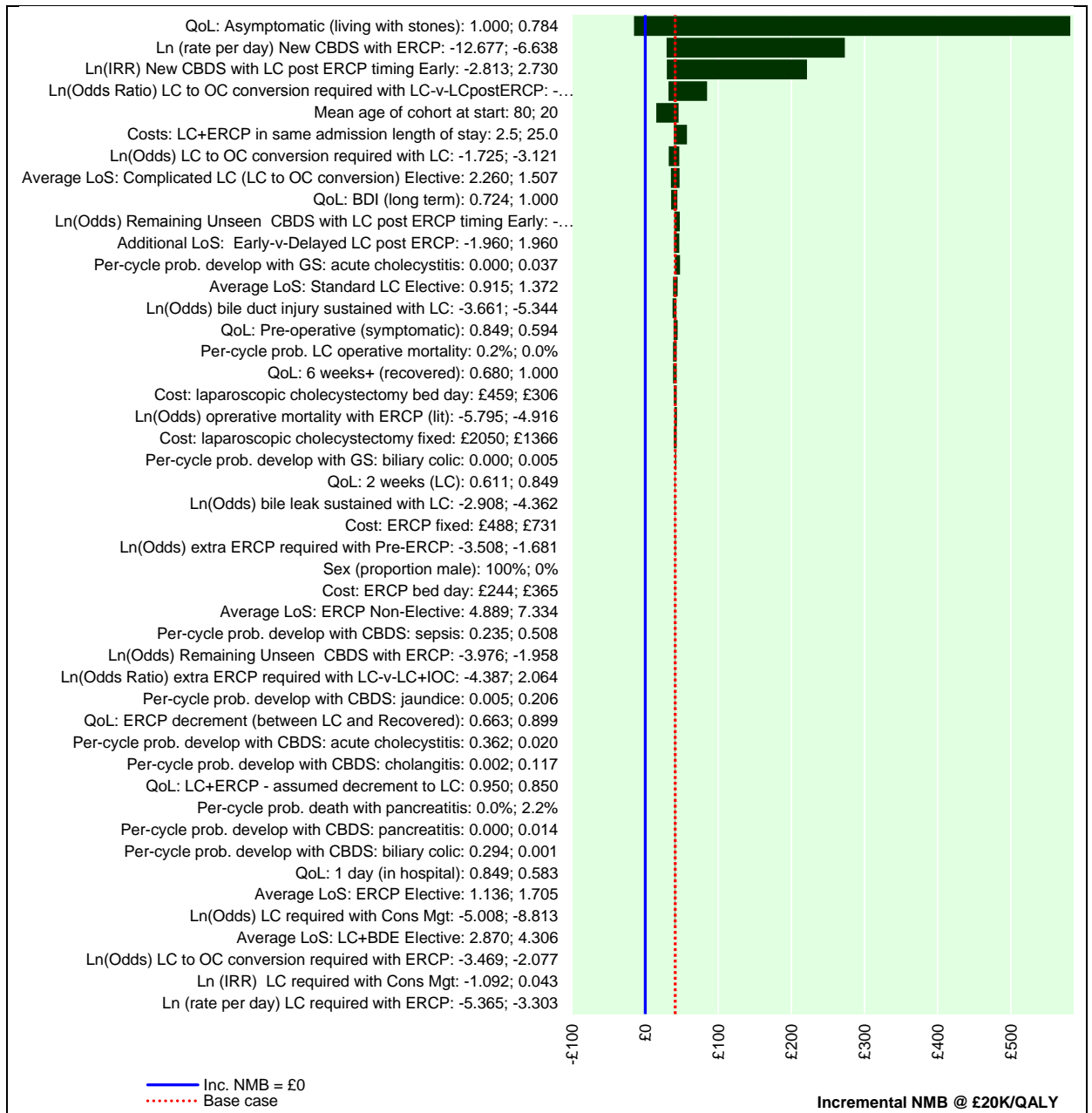

1 **Figure 30: Tornado plot of one-way sensitivity analysis for early versus delayed**  
 2 **laparoscopic cholecystectomy following ERCP**  
 3

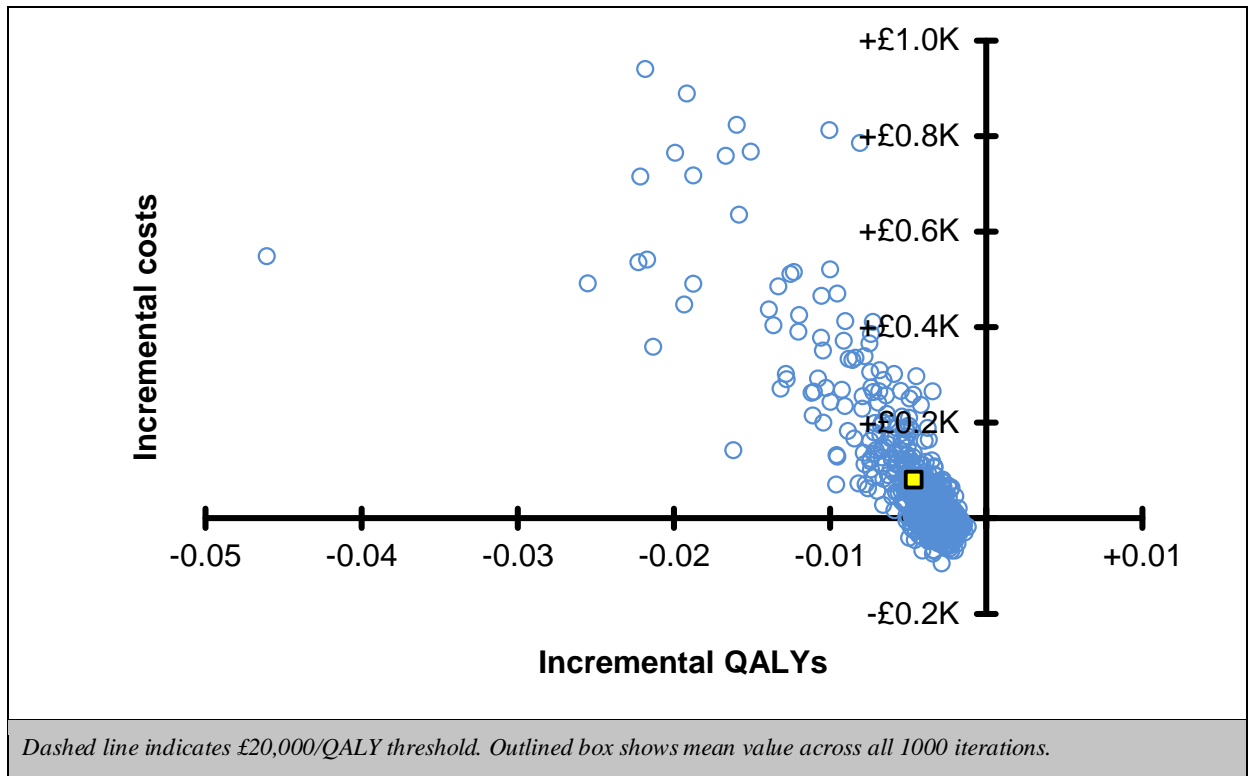

1 **Figure 31: Scatter plot of incremental costs and QALYs for early versus delayed**  
 2 **laparoscopic cholecystectomy following ERCP**  
 3  
 4

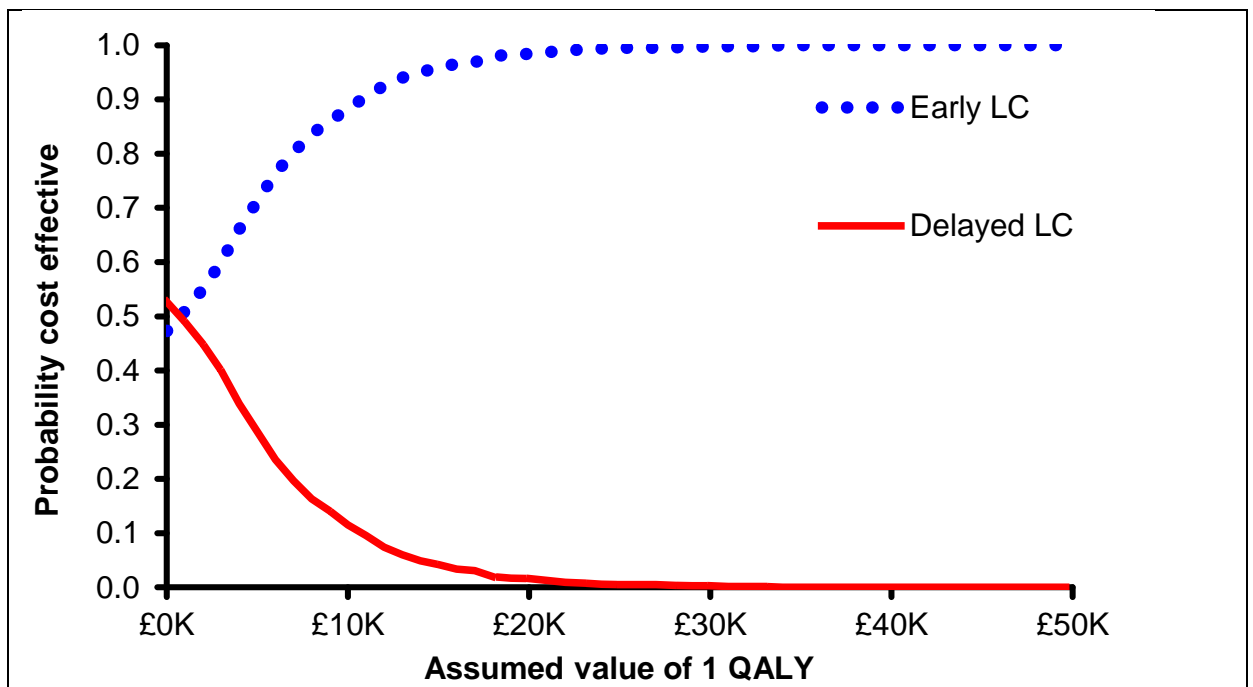

5 **Figure 32: Cost effectiveness acceptability curve for early versus delayed**  
 6 **laparoscopic cholecystectomy following ERCP**  
 7  
 8

## 3.4 Discussion

### 3.4.1 Principal findings

3 An original health economic model has been developed to analyse options in the  
4 management of gallstone disease. Across a number of comparisons, the health economic  
5 analysis supports early intervention for symptomatic gallstones or CBDS. Any upfront cost of  
6 operations outweighs the long-term costs and QALY losses from not intervening.

7 Sensitivity analyses indicate that, in comparators where the gallbladder is not removed, the  
8 model is sensitive to related parameters, such as utility losses from living asymptotically  
9 or symptomatically with gallstones, gallbladder cancer incidence, starting age or rates of  
10 developing symptoms.

### 3.4.2 Model strengths

12 This is the first health economic model to address a number of key issues in analysing the  
13 cost effectiveness of interventions to manage gallstone disease.

14 No existing cost–utility analyses have used a Markov structure to model gallstones. This  
15 allowed symptom and CBDS recurrence to be modelled and symptoms to occur over time  
16 (rather than at a fixed interval). Also, more detailed short-term operative consequences than  
17 have previously been considered could be included. A lifetime horizon incorporated long-  
18 term utility impacts of bile duct injuries.

19 The primary source of data for the model was the systematic review of randomised evidence  
20 undertaken for this guideline. The model structure allowed less reliance to be placed on  
21 parameters drawn from external observational evidence than is commonly seen in analogous  
22 cost–utility models.

23 This analysis represents the first UK cost–utility analysis comparing multiple interventions for  
24 the management of CBDS. A small number of analyses (Brown et al. 2011; Urbach et al.  
25 2001) have previously undertaken multiple comparisons, but did not use utility as an  
26 outcome.

27 The flexible nature of the model states allowed many comparisons to be analysed using the  
28 same model structure. Future guidelines or updates to this guideline may be able to utilise  
29 this existing model, to incorporate new evidence on the questions answered here and/or to  
30 explore other questions and scenarios.

### 3.4.3 Model limitations

32 Whilst the model has much strength, it also has a number of limitations that need to be  
33 considered.

34 The heavy reliance on data from included RCTs imposes some limitations on the analysis.  
35 Results are often sensitive to parameters with zero or small numbers of events in the  
36 included studies (such as bile duct injuries). Two comparisons rely on single clinical studies  
37 (laparoscopic cholecystectomy versus conservative management, laparoscopic  
38 cholecystectomy timing post ERCP) and a number rely on just 2 studies, which may limit the  
39 generalisability of findings for those questions. In addition, we may have excluded some  
40 important operative consequences that were not reported in the included papers. However,  
41 the GDG agreed the list of operative consequences to be modelled and this list was selected  
42 after reviewing the existing clinical and economic evidence. Using a wider pool of evidence,  
43 including nonrandomised studies, may have prevented some of the issues that arose with  
44 zero and small event counts for rare consequences; however, this would also increase risk of  
45 bias.

- 1 Structurally, the model assumes that symptoms are mutually exclusive in a way that is  
2 unlikely to be clinically realistic. Modelling multiple symptoms would complicate the model in  
3 a manner that may make it unsuitable for a Markov structure and lead to the need for a  
4 discrete event simulation structure that could encompass memory of patients' previous  
5 symptoms.
- 6 The model would be improved by using micro-costing for the different interventions. Also,  
7 symptoms are likely to incur NHS costs such as prescriptions, GP visits or A&E attendances.  
8 The lack of a cost associated with mending bile duct injuries possibly biases the analysis in  
9 favour of those interventions with higher rates of bile duct injury.
- 10 In order to estimate a bed-day cost for laparoscopic cholecystectomy and ERCP, it was  
11 necessary to assume that elective and non-elective surgery have the same fixed costs. This  
12 is particularly an issue for intraoperative ERCP and bile duct exploration, where costs only  
13 differ by a small length of stay found in the clinical evidence.
- 14 The model has not explicitly considered the costs or opportunity costs of implementing  
15 potential changes to clinical practice. This is particularly an issue for the comparison of  
16 laparoscopic cholecystectomy with bile duct exploration to laparoscopic cholecystectomy  
17 with pre-, intra- or postoperative ERCP. In this analysis laparoscopic cholecystectomy with  
18 intraoperative ERCP appears an attractive option. However, the GDG advised that few units  
19 are currently configured in a way that would make it simple to adopt this approach as a  
20 matter of routine (in particular, the elective lists of surgeons and radiologists tend not to be  
21 synchronised in a way that would make it simple to coordinate surgery and ERCP).  
22 Therefore, it may be that additional costs would be incurred in providing this treatment  
23 option, in which case, our analysis would overestimate the cost effectiveness of the  
24 approach.
- 25 A lack of UK utility data derived using EQ-5D that is specific to gallstones appears to be a  
26 major weakness of this model, although we note that the model is rarely sensitive to such  
27 parameters. However, better utility data would improve the face-validity and reliability of the  
28 analyses. There are a number of states where utility values have been assumed, including  
29 ERCP, asymptomatic gallstones and symptomatic gallstones. Also, the assumption that all  
30 symptoms incur the same utility losses is a significant simplification of a complex range of  
31 experiences.
- 32 The model relies on a number of assumptions around the timing of interventions, particularly  
33 that known CBDS are cleared by a maximum of 2 ERCPs that are conducted within the  
34 same 2-week cycle. The model could be improved by adding a state to represent extra  
35 ERCPs required to clear the bile duct, the timing of which could then be modelled more  
36 flexibly.

### 3.474 Comparison with other health economic analyses

- 38 Two existing cost–utility analyses that compared included interventions were identified  
39 (Gurusamy et al. 2012; Wilson et al. 2010).
- 40 Wilson et al. (2010) compared early and delayed laparoscopic cholecystectomy for acute  
41 cholecystitis and found early laparoscopic cholecystectomy dominates delayed laparoscopic  
42 cholecystectomy. Our analysis found that early laparoscopic cholecystectomy is cost  
43 effective compared with delayed laparoscopic cholecystectomy. Whilst the decision is similar,  
44 the conclusions are different. This is likely to be because Wilson et al. (2010) used a decision  
45 tree structure with fixed timing of symptoms and only modelled 1 year rather than a patient  
46 lifetime. When we limit the time horizon of our model to 1 year, we replicate Wilson et al.'s  
47 result.
- 48 Gurusamy et al. (2012) compared preoperative and intraoperative ERCP and, like this  
49 analysis found that intraoperative ERCP dominates pre-operative ERCP. This analysis



- 1 conducted a more thorough comparison of 4 treatment options and again, differences in
- 2 costs and QALYs gained are likely to be due to model structure and time horizon.

### **3.5 Conclusions**

- 4 An original health economic model has analysed a number of treatment comparisons in the
- 5 management of gallstone disease. The analyses support early intervention for symptomatic
- 6 gallstones and CBDS. Despite a number of limitations (primarily reflecting weaknesses in the
- 7 underlying data), this Markov model has many strengths and represents an important step
- 8 change in health economic analyses of gallstones.
- 9

Reference List

- Ainslie WG, Catton JA, Davides D et al. (2003) Micropuncture cholecystectomy vs conventional laparoscopic cholecystectomy: a randomized controlled trial. *Surgical Endoscopy* 17: 766-72
- Ara R, Brazier J (2008) Deriving an algorithm to convert the eight mean SF-36 dimension scores into a mean EQ-5D preference-based score from published studies (where patient level data are not available). *Value in Health* 11: 1131-43
- Arseneau KO, Cohn SM, Cominello F et al. (2001) Cost–utility of initial medical management for Crohn's disease perianal fistulae. *Gastroenterology* 120: 1640-56
- Attili AF, De SA, Capri R et al. (1995) The natural history of gallstones: the GREPCO experience. The GREPCO Group. *Hepatology* 21: 655-60
- Bass EB, Pitt HA, Lillemoe KD (1993) Cost-effectiveness of laparoscopic cholecystectomy versus open cholecystectomy. *American Journal of Surgery* 165: 466-71
- Bitzer EM, Lorenz C, Nickel S et al. (2008) Assessing patient-reported outcomes of cholecystectomy in short-stay surgery. *Surgical Endoscopy* 22: 2712-9
- Boerma D, Rauws EA, Keulemans YC et al. (2002) Wait-and-see policy or laparoscopic cholecystectomy after endoscopic sphincterotomy for bile-duct stones: a randomised trial. *Lancet* 360: 761-5
- Burney RE, Jones KR (2002) Ambulatory and admitted laparoscopic cholecystectomy patients have comparable outcomes but different functional health status. *Surgical Endoscopy* 16: 921-6
- Carraro A, Mazloun DE, Bihl F (2011) Health-related quality of life outcomes after cholecystectomy. [Review]. *World Journal of Gastroenterology* 17: 4945-51
- Chiang DT, Anozie A, Fleming WR et al. (2004) Comparative study on acute pancreatitis management. *ANZ Journal of Surgery* 74: 218-21
- Cook J, Richardson J, Street A (1994) A cost utility analysis of treatment options for gallstone disease: methodological issues and results. *Health Economics* 3: 157-68
- de Reuver PR, Sprangers MA, Rauws EA et al. (2008) Impact of bile duct injury after laparoscopic cholecystectomy on quality of life: a longitudinal study after multidisciplinary treatment. *Endoscopy* 40: 637-43
- Department of Health (2012) National Schedule of Reference Costs 2011-2012.

Dunn D, Nair R, Fowler S et al. (1994) Laparoscopic cholecystectomy in England and Wales: results of an audit by the Royal College of Surgeons of England. *Annals of the Royal College of Surgeons of England* 76: 269-75

Eypasch E, Williams JI, Wood-Dauphinee S et al. (1995) Gastrointestinal Quality of Life Index: development, validation and application of a new instrument. *British Journal of Surgery* 82: 216-22

Fan ST, Lai EC, Mok FP et al. (1993) Early treatment of acute biliary pancreatitis by endoscopic papillotomy. *New England Journal of Medicine* 328: 228-32

Gregor JC, Ponich TP (1996) Should ERCP be routine after an episode of 'idiopathic' pancreatitis? A cost-utility analysis. *Gastrointest.Endosc* 44: 118-23

Gurusamy K, Wilson E, Burroughs AK et al. (2012) Intraoperative vs preoperative endoscopic sphincterotomy in patients with gallbladder and common bile duct stones: cost-utility and value-of-information analysis. *Applied Health Economics & Health Policy* 10: 15-29

Kaltenthaler E, Tappenden P, Paisley S et al. (11 A.D.) Identifying and Reviewing Evidence to Inform the Conceptualisation and Population of Cost-Effectiveness Models.

Keus F, de VJ, Gooszen HG et al. (2008) Laparoscopic versus small-incision cholecystectomy: health status in a blind randomised trial. *Surgical Endoscopy* 22: 1649-59

Kind P, Hardman G, Macran S (1999) UK Population Norms for EQ-5D. 172

Korolija D, Sauerland S, Wood-Dauphinee S et al. (2004) Evaluation of quality of life after laparoscopic surgery: evidence-based guidelines of the European Association for Endoscopic Surgery. [Review] [147 refs]. *Surgical Endoscopy* 18: 879-97

Landman MP, Feurer ID, Moore DE et al. (2012) The long-term effect of bile duct injuries on health-related quality of life: a meta-analysis. *HPB (Oxford)* 15: 252-9

Lau JY, Leow CK, Fung TM et al. (2006) Cholecystectomy or gallbladder in situ after endoscopic sphincterotomy and bile duct stone removal in Chinese patients. *Gastroenterology* 130: 96-103

Lee L, Kaneva P, Latimer E et al. (2014) Mapping the Gastrointestinal Quality of Life Index to Short-Form 6D utility scores. *Journal of Surgical Research* 186: 135-41

Macafee DA, Humes DJ, Bouliotis G et al. (2009) Prospective randomized trial using cost-utility analysis of early versus delayed laparoscopic cholecystectomy for acute gallbladder disease. *British Journal of Surgery* 96: 1031-40

Moore DE, Feurer ID, Holzman MD et al. (2004) Long-term detrimental effect of bile duct injury on health-related quality of life. *Archives of Surgery* 139: 476-81

National Institute for Health and Care Excellence (2010) Hepatocellular carcinoma (advanced and metastatic) - sorafenib (first line) (TA189).

National Institute for Health and Care Excellence (2013) Guide to Methods of Technology Appraisal.

NHS Information Centre for Health and Social Care (2014) Hospital Episodes Statistics.

North West Cancer Intelligence Service (2014) Pancreatic Cancer Mortality.

Office for National Statistics (2013) Interim Life Tables, England and Wales 2010-2012.

Penniston KL, Nakada SY (2007) Health Related Quality of Life Differs Between Male and Female Stone Formers. *The Journal of Urology* 178: 2435-40

Quintana JM, Cabriada J, Arostegui I et al. (2003) Quality-of-life outcomes with laparoscopic vs open cholecystectomy. *Surgical Endoscopy* 17: 1129-34

Quintana JM, Cabriada J, Arostegui I et al. (2005) Health-related quality of life and appropriateness of cholecystectomy. *Annals of Surgery* 241: 110-8

Willams EJ, Taylor S, Fairclough P et al. (2006) Are we meeting the standards set for endoscopy? Results of a large-scale prospective survey of endoscopic retrograde cholangio-pancreatograph practice. *Gut* 56: 821-9

Wilson E, Gurusamy K, Gluud C et al. (2010) Cost-utility and value-of-information analysis of early versus delayed laparoscopic cholecystectomy for acute cholecystitis. *British Journal of Surgery* 97: 210-9