



Technology Assessment Report commissioned by the NIHR HTA Programme on behalf of the National Institute for Health and Clinical Excellence

Title: Rituximab for the first-line treatment of stage III-IV follicular lymphoma (Review of TA 110): systematic review and economic evaluation

Produced by ScHARR, University of Sheffield

Authors Diana Papaioannou, Research Fellow, ScHARR
Rachid Rafia, Research Associate, ScHARR
John Rathbone, Research Associate, ScHARR
Matt Stevenson, Reader in Health Technology Assessment and Technical Director of ScHARR Technology Assessment Group
Helen Buckley Woods, Information Specialist

Correspondence to Diana Papaioannou
Research Fellow
ScHARR
University of Sheffield
Regent Court
30 Regent Street
Sheffield
S1 4DA
Tel: +44 (0) 114 2220766
Email: d.papaioannou@sheffield.ac.uk

Date completed 18th April 2011

Source of funding: This report was commissioned by the NIHR HTA Programme as project number 09/141/01.

Declared competing interests of the authors

None

Declared competing interests of the clinical advisors/peer reviewers

Dr Andrew McMillan, Consultant in Haematology (Clinical advisor)

Personal pecuniary interest:

- 1) Financial support from Roche to attend conferences American Society of Haematology (ASH), European Haematology Association (EHA) and International Conference on Malignant Lymphoma (ICML) over the last years (5+),
- 2) Honoraria from Roche Advisory Boards (5+),
- 3) Honoraria from Roche for lectures e.g. Satellite Symposium (3+),
- 4) Honoraria from Napp pharmaceuticals for advisory board for Bendamustine hydrochloride.

Dr Matthew Lyttelton, Consultant Haematologist, Kettering General Hospital NHS Foundation Trust (commented on a draft version of this report)

Personal non-pecuniary interest

- 1) Supported by educational grants from Roche for travel and accommodation at international meetings.

Acknowledgements

The following team of clinical advisors gave substantial advice throughout the project and provided peer review of the report:

Professor Patrick Chu, Consultant in Haematology, Royal Liverpool University Hospital

Dr Andrew McMillan, Consultant in Haematology, Nottingham University Hospitals NHS Trust

The authors wish to thank Gill Rooney for her help in preparing and formatting the report, John Stevens for providing statistical advice, Professor Adrian Bagust, Dr Matthew Lyttelton and Dr Josh Wright and Dr Eva Kaltenthaler for peer reviewing the report.

Rider on responsibility for report

The views expressed in this report are those of the authors and not necessarily those of the NIHR HTA Programme. Any errors are the responsibility of the authors.

This report should be referenced as follows: Papaioannou, D, Rafia, R, Rathbone, J, Stevenson, M and Buckley Woods, H. Rituximab for the first-line treatment of stage III-IV follicular lymphoma (Review of TA 110). *Health Technol Assess*

Contributions of authors

Diana Papaioannou was the Assessment Group lead and undertook the clinical effectiveness review. Rachid Rafia undertook the cost-effectiveness review and developed the cost-effectiveness model. Matt Stevenson advised on the cost-effectiveness review and development of the cost-effectiveness model. John Rathbone helped undertake the clinical effectiveness review. Helen Buckley Woods performed the literature searches.

About ScHARR

The School of Health and Related Research (ScHARR) is one of the nine departments that comprise the Faculty of Medicine, Dentistry and Health at the University of Sheffield. ScHARR specialises in health services and public health research, and the application of health economics and decision science to the development of health services and the improvement of the public health.

The ScHARR Technology Assessment Group (ScHARR-TAG) synthesises research on the clinical and cost-effectiveness of healthcare interventions for the NIHR Health Technology Assessment Programme on behalf of a range of policy makers, including the National Institute of Health and Clinical Excellence. ScHARR-TAG is part of a wider collaboration of five units from other regions. The other units are: Southampton Health Technology Assessment Centre (SHTAC), University of Southampton; Aberdeen Health Technology Assessment Group (Aberdeen HTA Group), University of Aberdeen; Liverpool Reviews & Implementation Group (LRiG), University of Liverpool; Peninsular Technology Assessment Group (PenTAG), University of Exeter; and NHS Centre for Reviews and Dissemination, University of York.

Word count: 56,837

TABLE OF CONTENTS

1.	DEFINITION OF TERMS AND LIST OF ABBREVIATIONS	1
	DEFINITION OF TERMS	1
	LIST OF ABBREVIATIONS	4
2	EXECUTIVE SUMMARY	7
2.1	Background	7
2.2	Objectives	7
2.3	Methods	8
2.4	Results	9
2.5	Discussion	10
2.6	Conclusions	10
3	BACKGROUND	11
3.1.	Description of health problem	11
3.2.	Current service provision	18
3.3.	Description of technology under assessment	26
4.	DEFINITION OF THE DECISION PROBLEM	31
4.1	Decision problem	31
4.2	Overall aims and objectives of assessment	32
5.	ASSESSMENT OF CLINICAL EFFECTIVENESS	33
5.1	Methods for reviewing effectiveness	33
5.2	Results	39
6.	ASSESSMENT OF COST-EFFECTIVENESS	83
6.1	Systematic review of existing cost-effectiveness evidence	83
6.2	Assessment of the manufacturer's submission	97
6.3	Relevance of cost-effectiveness evidence for NICE decision making	110
6.4	Independent economic assessment	111
7.	ASSESSMENT OF FACTORS RELEVANT TO THE NHS AND OTHER PARTIES	204
8.	DISCUSSION	205
8.1	Statement of principal findings	205

8.2	Strengths and limitations of the assessment	206
8.3	Uncertainties	207
8.4	Other relevant factors	208
9.	CONCLUSIONS	209
9.1	Implications for service provision	209
9.2	Suggested research priorities	209
10.	APPENDICES	210
	Appendix 1: Incidence calculations and data sources for Non Hodgkin's lymphoma and Follicular Lymphoma	210
	Appendix 2: Ann Arbor Staging System	212
	Appendix 3: ECOG performance status	213
	Appendix 4: Deaths in England and Wales (including cancer and NHL deaths)	214
	Appendix 5: Literature Search Strategies	215
	Appendix 6: Response criteria for NHL	219
	Appendix 7: List of unobtainable references	221
	Appendix 8: List of reports of four included studies	224
	Appendix 9: List of excluded studies	229
	Appendix 10: List of excluded studies	262
	Appendix 11: Data extraction tables	264
	Appendix 12: Outcomes definitions for time to event data	303
	Appendix 13: Chi square test analysis for response rate data	305
	Appendix 14: Exploratory meta-analyses	309
	Appendix 15: Full results of sensitivity analyses	315
	Appendix 16: Additional results for the scenario analysis incorporating first-line maintenance	333
	REFERENCES	336

LIST OF TABLES AND FIGURES

Tables

Table 1	Incidence of FL in England and Wales	11
Table 2	NHL prevalence in England and Wales at 31st December 2006	12
Table 3	International Prognostic Index	17
Table 4	Relevant NICE guidance for the treatment of advanced FL	23
Table 5	Survey results (patients N=120) for the first-line treatment of untreated stage III-IV FL in the UK	25
Table 6	Primary reports for each trial	39
Table 7	Ongoing trials in FL that meet the inclusion/exclusion criteria	42
Table 8	Summary of included studies	44
Table 9	Baseline demographic data for the four included studies	46
Table 10	Treatment regimens	49
Table 11	Clinical efficacy outcomes reported in four studies	51
Table 12	Response to treatment in the four included studies	56
Table 13	Overall survival in the four included studies	58
Table 14	Summary of other time to event data (includes PFS)	61
Table 15	Results of univariate analyses on TTP in M39021 trial for FLIPI subgroups	63
Table 16	PFS and OS by FLIPI subgroup in the OSHO-39 trial (reproduced from manufacturer's submission)	64
Table 17	Median TTP by IPI subgroup in the M39021 trial	65
Table 18	Median TTF by IPI subgroup in the GLSG trial	65
Table 19	Median TTF by age subgroup (<60 years versus ≥60 years) in GLSG -2000 trial	65
Table 20	Univariate analyses in the M39021 trial	66
Table 21	Number of treatment cycles administered	69
Table 22	Adverse events (grade 1 and 2) reported in the GLSG-2000 and OSHO-39 trials (Grade 1/2 adverse events not reported in M39021 trial and FL2000 trial)	72
Table 23	Adverse events (grade 3 and 4 combined) for all four trials	74
Table 24	Adverse events (grade 3 and 4 separately) reported in the GLSG-2000 and OSHO-39 trials (Grade 3/4 adverse events not reported separately in the M39021 trial and FL2000 trial)	75
Table 25	Number of deaths and reasons for death in the four trials	77
Table 26	Adverse events in the global rituximab safety database as of April 30, 2007 (all sources and indications): reproduced from the manufacturer's submission	79
Table 27	Tabulated summary of UK cost-effectiveness studies	86
Table 28	Critical appraisal checklist of the included economic evaluations	87

Table 29	Tabulated summary of the cost-effectiveness of the addition of rituximab to chemotherapy compared with chemotherapy alone (Adapted from Table 4 in Ray <i>et al.</i>)	91
Table 30	Critical appraisal checklist of the economic model included in the MS	97
Table 31	Tabulated summary of the economic model included in the MS	100
Table 32	Summary of the cost-effectiveness of the addition of rituximab to chemotherapy compared with chemotherapy alone included in the MS	103
Table 33	Tabulated summary of the “most likely” treatment options in patients treated in first-line induction with CVP or CHOP with or without rituximab as indicated by clinical experts	114
Table 34	Treatment pathway incorporating maintenance	115
Table 35	Height, Weight and estimated BSA in FL patients from the PRIMA study by gender	124
Table 36	Response rate in first-line induction	125
Table 37	Goodness of fit criteria for the risk of progression among responders to CVP first-line induction with or without distribution	126
Table 38	Goodness of fit criteria for the risk of progression among non-responders to CVP first-line induction with or without distribution	130
Table 39	Response rates among patients receiving second-line induction treatment	139
Table 40	Summary of data from the EORTC 20981 trial	140
Table 41	The rates of adverse events and management costs used in the economic model	149
Table 42	Dose and number of cycle used in the economic model	151
Table 43	Drug administration costs	152
Table 44	Drug acquisition and administration costs by chemotherapy cycle per patient in first-line induction	153
Table 45	Treatment protocol for ESHAP	153
Table 46	Monitoring and management at the end of treatment induction/maintenance	155
Table 47	Unit costs applied to estimate monitoring cost	156
Table 48	Post protocol treatment and mean cost associated with third/subsequent line of therapy according to the choice of second-line induction treatment/maintenance	157
Table 49	Health state utilities presented in the main analysis with patients assigned to five possible health states	163
Table 50	Aggregation of health state utilities	163
Table 51	Number of patients in each disease state that have received from 0 to 6 previous treatments	164
Table 52	Summary of parameters used in the economic model	168
Table 53	Base case deterministic cost-effectiveness of the addition of rituximab to CVP estimated by the AG	171
Table 54	Base case deterministic cost-effectiveness of the addition of rituximab to CHOP estimated by the AG	171
Table 55	Base case deterministic cost-effectiveness of the addition of rituximab to MCP estimated by the AG	172
Table 56	Base case analysis: Probabilistic cost-effectiveness of the addition of rituximab	175

	to CVP estimated by the AG	
Table 57	Base case analysis: Probabilistic cost-effectiveness of the addition of rituximab to CHOP estimated by the AG	176
Table 58	Base case analysis: probabilistic cost-effectiveness of the addition of rituximab to MCP estimated by the AG	176
Table 59	SA: Varying the time horizon	177
Table 60	SA: Choice of parametric distribution	178
Table 61	SA: Varying the rate of progression attributable to death	179
Table 62	SA: Assuming a reduced effectiveness in second-line, in patients previously treated with rituximab	180
Table 63	SA: Varying the maximum time a patient can stay in PFS1	181
Table 64	SA: Assuming a higher survival in patients treated with rituximab in second-line	182
Table 65	SA: Varying health state utilities	183
Table 66	SA: Varying the modelled treatment pathway	184
Table 67	SA: Varying management costs	185
Table 68	SA: Varying the maximum age at which patients can receive aggressive therapies	186
Table 69	SA: Varying the BSA	186
Table 70	Scenario analysis: deterministic cost-effectiveness of the addition of rituximab to CVP estimated by the AG	187
Table 71	Scenario analysis: deterministic cost-effectiveness of the addition of rituximab to CHOP estimated by the AG	187
Table 72	Scenario analysis: deterministic cost-effectiveness of the addition of rituximab to MCP estimated by the AG	188
Table 73	Scenario analysis: probabilistic cost-effectiveness of the addition of rituximab to CVP estimated by the AG	188
Table 74	Scenario analysis: probabilistic cost-effectiveness of the addition of rituximab to CHOP estimated by the AG	189
Table 75	Scenario analysis: probabilistic cost-effectiveness of the addition of rituximab to MCP estimated by the AG	190
Table 76	SA: Varying the time horizon	191
Table 77	SA: Choice of parametric distribution	191
Table 78	SA: Assumption about the effect of first-line maintenance rituximab	192
Table 79	SA: Assuming a reduced effectiveness in second-line, in patients previously treated with rituximab	193
Table 80	SA: Varying the maximum time a patient can stay in PFS1	194
Table 81	SA: Varying the modelled treatment pathway	195
Table 82	Comparison of the ICER produced by the MS and AG model	198

Figures

Figure 1	Treatment pathway for stage III/IV FL (adapted from manufacturer's submission)	19
Figure 2	PRISMA (adapted) Flow Diagram	38
Figure 3	Network of evidence	41
Figure 4	Quality assessment of the included trials	53
Figure 5	Flow diagram of economic evaluation selection/exclusion	84
Figure 6	Model structure included in the MS (reproduction of Figure 3, p.104 in the MS)	99
Figure 7	KM plot and Exponential distributions presented in the MS and used in the economic model for patients that respond to R-CHOP second-line induction treatment and receive maintenance rituximab	105
Figure 8	KM plot and Exponential distribution used to calculate PPS reported in the MS and actually used in the economic model for patients receiving observation after response to second-line induction treatment	107
Figure 9	KM plot and Exponential distribution used to calculate PPS reported in the MS and actually used in the economic model for patients receiving maintenance rituximab after response to second-line induction treatment	108
Figure 10	Treatment pathways modelled in the economic model for CVP	116
Figure 11	Treatment pathways modelled in the economic model for R-CVP	117
Figure 12	Treatment pathways modelled in the economic model for CHOP/MCP	118
Figure 13	Treatment pathways modelled in the economic model for R-CHOP/R-MCP	119
Figure 14	Schematic of the model structure	122
Figure 15	Age-distribution of patients diagnosed with FL in England and Wales	123
Figure 16	Plot of the observed KM and predicted distributions for patients treated with CVP	126
Figure 17	Plot of the observed KM and predicted distributions for patients treated with rituximab in addition to CVP	127
Figure 18	Plot of hazard for responders treated with CVP with or without rituximab	128
Figure 19	Log-normal regression model for responders to CVP containing regimen with or without rituximab	129
Figure 20	Plot of the observed KM and predicted distributions for non-responders treated with CVP	130
Figure 21	Plot of the observed KM and predicted distributions for non responders treated with rituximab in addition to CVP	131
Figure 22	Plot of hazard for non-responders treated with CVP with or without rituximab	132
Figure 23	Log-normal regression model for non-responders to CVP containing regimen with or without rituximab	133
Figure 24	Comparison of the KM for responders to R-CHOP and R-CVP in the PRIMA trial	134
Figure 25	Plot of the risk of progression among patients responding to first-line induction treatment with R-CVP from the PRIMA and M39021 trials	135
Figure 26	Comparison of the PFS from Rummel <i>et al.</i> and predicted using the AG	137

	method	
Figure 27	PFS for all patients treated with CVP, CHOP and MCP with or without rituximab	138
Figure 28	Plot of the KM and Log-normal for patients responding to CHOP second-line induction (from the end of treatment induction) with or without maintenance rituximab.	141
Figure 29	Plot of the KM and Log-normal for patients responding to R-CHOP second-line induction (from the end of treatment induction) with or without maintenance rituximab	141
Figure 30	Plot of the OS KM and Log-normal for responders to second-line induction (from end of treatment induction) with or without maintenance rituximab	142
Figure 31	Plot of the OS and PFS KM and Log-normal for non-responders to second-line induction treatment (from start of induction treatment)	142
Figure 32	Treatment pathway for patients treated with HDT with or without rituximab	144
Figure 33	EFS for patients treated with ASCT and salvage chemotherapy with or without rituximab	145
Figure 34	OS for patients treated with ASCT and salvage chemotherapy with or without rituximab	145
Figure 35	Flow diagram of Quality of life review selection/exclusion	161
Figure 36	Base case analysis: undiscounted life years	172
Figure 37	Base case analysis: discounted QALYs	173
Figure 38	Base case analysis: management and treatment costs for patients treated with CVP in first-line induction with or without rituximab	173
Figure 39	Base case analysis: management and treatment costs for patients treated with CHOP in first-line induction with or without rituximab	174
Figure 40	Base case analysis: management and treatment costs for patients treated with MCP in first-line induction with or without rituximab	174
Figure 41	Base case analysis: CEAC for R-CVP versus CVP alone	175
Figure 42	Base case analysis: CEAC for R-CHOP versus CHOP alone	176
Figure 43	Base case analysis: CEAC for R-MCP versus MCP alone	177
Figure 44	Comparison of the extrapolation using the Log-normal and Gompertz distribution for responders to R-CVP	179
Figure 45	Scenario analysis: CEAC for R-CVP versus CVP alone	189
Figure 46	Scenario analysis: CEAC for R-CHOP versus CHOP alone	190
Figure 47	Scenario analysis: CEAC for R-MCP versus MCP alone	190
Figure 48	Comparison of the undiscounted life years by treatment estimated by the MS and AG	196
Figure 49	Comparison of the discounted QALY by treatment estimated by the MS and AG	197
Figure 50	Comparison of discounted costs by treatment estimated by the MS and AG	197

1. DEFINITION OF TERMS AND LIST OF ABBREVIATIONS

Technical terms and abbreviations are used throughout this report. The meaning is usually clear from the context, but a glossary is provided for the non-specialist reader.

DEFINITION OF TERMS

Antibody	An immunoglobulin molecule that has a specific amino acid sequence by virtue of which it interacts only with the antigen that induced its synthesis in cells of the lymphoid series (especially plasma cells) or with antigen closely related to it. Antibodies are classified according to their mode of action as agglutinins, bacteriolysins, haemolysins, opsonins, precipitins, etc.
Antigen	A substance that is capable, under appropriate conditions, of inducing a specific immune response and of reacting with the products of that response, that is, with specific antibodies or specifically sensitised T-lymphocytes, or both. Antigens may be soluble substances, such as toxins and foreign proteins, or particulates, such as bacteria and tissue cells; however, only the portion of the protein or polysaccharide molecule known as the antigenic determinant (epitopes) combines with antibody or a specific receptor on a lymphocyte.
B-cell	A type of lymphocyte normally involved in the production of antibodies to combat infection. It is a precursor to a plasma cell. During infections, individual B-cell clones multiply and are transformed into plasma cells, which produce large amounts of antibodies against a particular antigen on a foreign microbe. This transformation occurs through interaction with the appropriate CD4 T-helper cells.
CD20	Unglycosylated phosphoproteins expressed only on B-cells. They are regulators of transmembrane calcium conductance and thought to play a role in B-cell activation and proliferation.
Disease-free survival ^a	The time from complete response to relapse or death (not specified) (as defined in the M39021 trial).
Event-free survival ^a	The time period from randomisation to disease progression/relapse, death by any cause or new antilymphoma treatment (FL200 trial). The time period from randomisation to disease progression after 2 cycles or partial response at 6 cycles or disease progression/relapse, (OSHO-39 trial).
FL2000 trial	An open-label randomised controlled trial comparing R-CHVPi versus CHVPi for the first-line treatment of stage III-IV follicular lymphoma
Follicular lymphoma	A type of Non-Hodgkin's lymphoma, named as such because of the location (lymphoid follicles) and behaviour (growth in a follicular fashion) of the cancerous cells.

GLSG-2000 trial	An open-label randomised controlled trial comparing R-CHOP versus CHOP for the first-line treatment of stage III-IV follicular lymphoma.
Granulocytopenia	A decrease in the numbers of granulocytes, which are a type of white blood cell which help fight infection.
Indolent disease	Disease which develops slowly.
Leukocytopenia	A marked decrease in the numbers of white blood cells, which can increase the risk of infection.
Lymph	The almost colourless fluid that bathes body tissues and is found in the lymphatic vessels that drain the tissues of the fluid that filters across the blood vessel walls from blood. Lymph carries lymphocytes that have entered the lymph nodes from the blood.
Lymphocyte	White cells of the blood that are derived from stem cells of the lymphoid series. Two main classes are recognised, T and B lymphocytes, the latter responsible (when activated) for production of antibody, the former subdivided into subsets (helper, suppressor, cytotoxic T-cells) and responsible both for cell mediated immunity and for stimulating B-cells.
Lymphoma	Malignant tumour of lymphoid cells. Lymphomas are of either Hodgkin's or non-Hodgkin's type.
M39021 trial	An open-label randomised controlled trial comparing R-CVP versus CVP for the first-line treatment of stage III-IV follicular lymphoma.
Monoclonal antibodies	An antibody made by a single clone of cells.
Neutropenia	A marked decrease in the numbers of neutrophils, a type of granulocyte, which can increase the risk of infection.
Non-Hodgkin's lymphoma	A group of lymphomas which differ in important ways from Hodgkin's disease and are classified according to the microscopic appearance of the cancer cells. There are many different subtypes of non-Hodgkin's lymphoma; some of these are fast growing and life threatening, others are slow growing and may not require immediate treatment.
OSHO-39 trial	An open-label randomised controlled trial comparing R-MCP versus MCP for the first-line treatment of stage III-IV follicular lymphoma.
Overall survival	The time from randomisation to the date of death by any cause.
Progression-free survival	The time from randomisation to disease progression or death.
Response duration ^a	The time from response achieved (complete or partial) to disease progression/relapse or death.
	A class of lymphocytes, so called because they are derived from the thymus and

T-cell	have been through thymic processing. Involved primarily in controlling cell-mediated immune reactions and in the control of B-cell development. The T-cells coordinate the immune system by secreting lymphokine hormones
Time to next antilymphoma treatment ^a	The time from randomisation to date of next/new treatment (OSHO-39 and M39021 trial) or death (M39021 trial)
Time to progression ^a	The time from randomisation to disease progression, relapse after response, death by any cause (M39021 trial)
Time to treatment failure ^a	The time period from randomisation to death, relapse after response, new antilymphoma treatment or stable disease after cycle 4 (M39021 trial). The time period from start of treatment to resistance to initial therapy, disease progression or death (GLSG-2000 trial).

^aNo standard definitions exist. Definitions taken from four trials included in this appraisal.

LIST OF ABBREVIATIONS

AE	Adverse event
AG	Assessment Group
AIC	Akaike Information Criteria
ASCT	Autologous stem cell transplant
BEAM	BCNU [®] /carmustine, cytarabine, etoposide, melphalan
BIC	Bayesian Information Criteria
BNF	British National Formulary
BSA	Body surface area
CEAC	Cost-effectiveness acceptability curve
CHOP	Cyclophosphamide, doxorubicin/adriamycin, vincristine and prednisolone
CHVPi	Cyclophosphamide, doxorubicin, etoposide, prednisolone and interferon- α
CI	Confidence interval
CNOP	Cyclophosphamide, mitoxantrone, vincristine and prednisolone
CR	Complete response/responder
CRD	Centre for Reviews and Dissemination
CRu	Unconfirmed complete response/responder
CVP	Cyclophosphamide, vincristine and prednisolone
DFS	Disease-free survival
DLBCL	Diffuse large B-cell lymphoma
ECOG	Eastern Cooperative Oncology Group
EFS	Event-free survival
EFSR	Event free survival after first relapse
EQ-5D	EuroQol-5D
ERG	Evidence Review Group
ESMO	European Society for Medical Oncology
EVPI	Expected value of perfect
FACT	Functional Assessment of Cancer Therapy
FACT-LYM	Functional Assessment of Cancer Therapy (lymphoma)
FC	Fludarabine, Cyclophosphamide
FL	Follicular lymphoma
FL2000	Follicular lymphoma-2000 trial (R-CHVPi vs. CHVPi)
FLIPI	Follicular Lymphoma International Prognostic Index
FCM	Fludarabine, chlorambucil and mitoxantrone
FM	Fludarabine and mitoxantrone

GLSG-2000	German Low Grade Lymphoma Study- 2000 (R-CHOP vs. CHOP)
GCSF	Granulocyte colony-stimulating factor
HDT	High dose chemotherapy
HRQoL	Health-related quality of life
ICER	Incremental cost-effectiveness ratio
IPI	International Prognostic Index
ITT	Intention to treat
IWF	International Working Formulation
KM	Kaplan Meier
LDH	Lactate dehydrogenase
LY	Life years
LYG	Life years gained
M39021	R-CVP vs. CVP trial
MCL	Mantle cell lymphoma
MCP	Mitoxantrone, chlorambucil and prednisolone
NHL	Non-Hodgkin's lymphoma
NHS	National Health Service
NICE	National Institute for Health and Clinical Excellence
ORR	Overall response rate
OS	Overall survival
OSHO	East German society of haematology and oncology
OSHO-39	R-MCP vs. MCP trial
PFS	Progression free survival
PR	Partial response/responder
PRISMA	Preferred reporting items for systematic reviews and meta-analyses
PSA	Probabilistic Sensitivity Analysis
QALY	Quality-adjusted life year
RCT	Randomised controlled trial
REAL	Revised European American Lymphoma
R-DHAP	Rituximab, dexamethasone, cytarabine, cisplatin
R-ESHAP	Rituximab, etoposide, methylprednisolone, cytarabine, cisplatin
R-ICE	Rituximab, ifosfamide, carboplatin, etoposide
RMSE	Root mean square error
SAR	Survival after first relapse
ScHARR	School of Health and Related Research
TTF	Time to treatment failure

TTNT	Time to next antilymphoma treatment
TTP	Time to treatment progression
VAS	Visual Analogue Scale
WHO	World Health Organisation
WTP	Willingness to pay

2. EXECUTIVE SUMMARY

2.1 Background

Non-Hodgkin's lymphoma (NHL) is a cancer of the lymphatic tissue, causing enlargement of lymph nodes and generalised symptoms. Follicular lymphoma (FL), a clinical subtype of NHL, develops slowly and often without symptoms for many years. FL takes a relapsing and remitting course and median survival is 8-10 years, although more recent evidence suggest it could be as high as 15-20 years. In 2008, the incidence of FL in England and Wales was 3.4 per 100,000 persons. Over 70% of FLs are diagnosed in persons aged over 60 years, and 85-90% present with advanced disease, which is defined as lymph nodes on both sides of the diaphragm being involved (stage III) or disease is disseminated with one or more extra-lymphatic organ involved (stage IV).

Advanced FL is not curable, thus the aim of disease management is to both increase patient life expectancy and to increase patient health-related quality of life. For the majority of patients (90%), first-line therapy in stage III-IV FL is rituximab (R) and chemotherapy, with around two thirds receiving the cyclophosphamide, vincristine and prednisolone (CVP) regimen as the chemotherapy component of treatment. The next most frequent chemotherapy regimen is cyclophosphamide, doxorubicin, vincristine and prednisolone (CHOP) which accounts for 16% of other chemotherapy regimens. Patients who are less fit and/or elderly may receive chlorambucil as single agent chemotherapy. NICE reviewed the use of rituximab in Technology Appraisal (TA) number 110 in 2006, subsequently recommending the use of R-CVP as first-line treatment for symptomatic stage III-IV FL. Since TA110, the license for rituximab has been extended so that rituximab can be administered in combination with any chemotherapy for first-line treatment of symptomatic stage III-IV FL. Rituximab monotherapy as a maintenance treatment may follow for patients who have responded to first-line treatment with R-chemotherapy, which aims to delay relapse by stabilising response to initial therapy, eradicating any residual disease and maintaining remission after successful remission induction therapy.

2.2 Objectives

The aim of this assessment is to systematically evaluate and appraise the clinical and cost-effectiveness of rituximab (in its licensed indication) in combination with chemotherapy compared with non-rituximab containing chemotherapy, for the first-line treatment of symptomatic stage III-IV FL.

2.3 Methods

Eleven electronic databases were searched from inception in September to October 2010: MEDLINE including Medline in process; CINAHL; EMBASE; The Cochrane Library including the Cochrane Database of Systematic Reviews, Cochrane Controlled Trials Register, DARE, NHS EED and HTA databases; Science Citation Index; BIOSIS. Ongoing research was searched using clinical trials databases and registers. Relevant conference proceedings were searched and the reference lists of relevant articles and sponsor submissions were handsearched.

Comparative studies were selected for review if they addressed the clinical or cost-effectiveness of adding rituximab to chemotherapy. In addition, comparative studies which involved either an intervention or comparator defined in the decision problem (i.e. R-chemotherapy or chemotherapy alone) were selected for potential use in a network meta-analysis. The studies had to include symptomatic III-IV FL patients and to be of randomised controlled trial (RCT) design. Outcomes had to include one or more of the following: response rates, response duration, overall survival (OS), progression-free survival (PFS) or duration of disease remission. The quality of the studies was assessed using criteria based on those proposed by the NHS Centre for Reviews and Dissemination. Data was abstracted into standardised data extraction forms. Findings were tabulated and discussed in a narrative synthesis.

A systematic review of economic evaluations addressing the cost-effectiveness of the addition of rituximab to chemotherapy compared with chemotherapy alone was conducted. There was also one manufacturer submission (Roche) for this assessment which included an economic model. In addition, a systematic review of the quality of life in FL was performed.

A probabilistic model was developed by the Assessment Group (AG) to assess the cost-effectiveness of the addition of rituximab to CVP, CHOP and MCP (mitoxantrone, chlorambucil and prednisolone) from a NHS perspective. The model has four health states: PFS after first-line (PFS1), PFS after second-line (PFS2), progressive disease and death. Patients start in PFS1 and receive first-line induction with chemotherapy with or without rituximab. Patients who relapse move onto PFS2 and are assumed to receive second-line treatment with or without maintenance rituximab. After progression, patients enter a progressive state and remain in that state until death. The model uses a 25 years time horizon and costs and benefits are discounted at 3.5%. A scenario analysis is presented incorporating first-line maintenance in responder to first-line induction with R-chemotherapy.

2.4 Results

Summary of benefits and risks

Four RCTs comparing R- chemotherapy versus chemotherapy alone in untreated, symptomatic stage III-IV FL patients were identified.

R-chemotherapy compared with chemotherapy alone increased the likelihood of a response to treatment in all four trials, with no additional toxicity of clinical relevance. Overall response rates (ORR) were significantly improved in all four trials, with a difference between the R-chemotherapy and chemotherapy arms of between 5% and 24%. Complete response (CR) rates were also improved, with a difference between the R-chemotherapy and chemotherapy arms of between 2% and 25%. Exploratory meta-analyses were conducted to explore the results of synthesising the ORR, CR and PR from the four trials. The level of statistical heterogeneity was very high and the AG therefore believes the response rates from the individual trials to be a more robust estimator of the efficacy of the specific R-chemotherapy regimens. These are subsequently used in the decision model.

Over a follow-up period of 4 to 5 years, R-chemotherapy significantly increased the OS rate compared with chemotherapy alone in three trials. The trials presented evidence that R-chemotherapy prolonged other clinical outcomes such as response duration, time to treatment failure, time to progression, time to next anti-lymphoma treatment, event-free survival and disease-free survival, compared with chemotherapy alone.

Summary of cost-effectiveness

The Incremental Cost-Effectiveness Ratios (ICERs) for the addition of rituximab to CVP, CHOP and MCP is £7,720, £10,834 and £9,316 per QALY gained respectively when it was assumed that first-line rituximab maintenance was not used.

When it was assumed that patients responding to first-line induction with R-chemotherapy receive first-line maintenance rituximab for up to 2 years, the ICERs increases to £14,959, £21,687 and £20,493 per QALY gained respectively. Sensitivity analyses indicated that the ICER was mostly sensitive to the assumptions about the time horizon, the choice of parametric distribution to model the effectiveness in first-line induction, the maximum time a patient can remain progression-free, assumptions regarding resistance to rituximab and the modelled treatment pathway. Results are not directly comparable across chemotherapies since they are selected in clinical practice with regard to factors including age, performance status and disease aggressiveness.

2.5 Discussion

The results from four randomised trials (of good quality) comparing R-chemotherapy with chemotherapy alone showed an improvement in a number of clinical effectiveness outcomes. These benefits are achieved with minimal clinically relevant additional adverse events or toxicity. It is noted that data for outcomes such as OS are compromised in three of the studies due to the use of additional treatments. Longer OS data follow-up would strengthen the findings as the median OS has not yet reached in any of the trials.

This assessment provides an indication of the cost-effectiveness of the addition of rituximab to CVP, CHOP and MCP in a UK setting. The model developed by the AG extends the analysis undertaken in previous economic models in terms of a greater level of detail in the modelled treatment pathway. A wide range of assumptions have also been examined in sensitivity analyses. However, there are some limitations relating to the sources of data used in the AG model for the effectiveness in first- and second-line and the assumed utility values. There is little evidence available regarding the effectiveness of R-CHOP and R-MCP in first-line induction. There is also uncertainty about the effect of salvage treatment in patients previously treated with an anthracycline regimen. Finally, there is uncertainty whether rituximab is as effective in second-line when patients have been previously treated with rituximab. The context for care and the mode of delivery is identical with the comparator therapies, thus there are no implications that do not also apply to chemotherapies alone.

Generalisability

It is noted that patients included in the trials were generally younger than those seen in clinical practice in the UK. This assessment is based on data involving the following chemotherapeutic agents: CVP, CHOP, MCP and CHVPi. It is not certain that the results can be generalised to other R-chemotherapy regimens.

2.6 Conclusions

The addition of rituximab to CVP, CHOP and MCP is likely to be clinically effective in the first-line treatment of stage III-IV FL. The cost per QALY gained is estimated to be below £25,000 for all three comparisons under our basecase assumption and is considerably lower if first-line rituximab maintenance is not assumed. The main uncertainties in terms of influencing the ICER relate to the effectiveness of rituximab re-treatment (i.e. resistance) and the effect of salvage treatment in patients previously treated with anthracycline-regimens. Assumptions were made and the best evidence identified was used when appropriate and available. Therefore, results have to be interpreted in line with the assumptions made and the quality of the evidence available.

3. BACKGROUND

3.1. Description of health problem

3.1.1 Epidemiology

Non-Hodgkin's lymphomas (NHLs) account for approximately 4% of all cancers diagnosed in the UK,¹ and are also the fifth most common cancer in the UK for both sexes combined (fifth in males and seventh in females).² In 2008, there were 10,319 new cases of NHL registered in England and Wales,³ and 3,978 registered deaths in 2008.⁴

Follicular lymphoma (FL) is a type of low grade or indolent NHL, where the cancer develops slowly, often without symptoms, for many years. FL is the second most common type of NHL within Western Europe and the USA⁵ and is reported to account for between 20-30% of all NHLs.^{6,7,8,9} The UK incidence of FL is approximately 3.4 per 100,000 (Table 1), and around 70% of all cases are diagnosed in people aged over 60 years.¹⁰ FL occurs equally in males and females. Most patients with FL present with advanced disease; approximately 50% of patients will present with bone marrow involvement (i.e. stage IV disease; details on staging FL are in a later section).

Over 70% of people with FL are still alive five years after the diagnosis,¹¹ with the ten-year predicted survival rate for patients in England and Wales in 2007 reported as 50.8%.² In the last decade, longer median survival has been reported, with one centre reporting median overall survival of up to 18 years,¹² and the percentage of survival at 20 years as high as 44%.¹³ Some have attributed this to novel therapeutic strategies^{14,15} including chemoimmunotherapy (i.e. chemotherapy and rituximab) and radioimmunotherapy. Relevant data on incidence and prevalence are provided in Table 1 and 2 respectively.

Table 1: Incidence of FL in England and Wales^a

	England	Wales	England and Wales
All NHLs: number of cases (2008)	9,676	643	10,319
All NHLs: crude rate per 100,000 (2008)	18.8	21.5	18.9
Follicular lymphoma: number of cases (2008)	1,757	112	1,869
Follicular lymphoma: crude incidence per 100,000 (2008)	3.4	3.7	3.4

^a All figures calculated using data from 2008 from the Office for National Statistics³ and

Welsh Cancer Intelligence & Surveillance Unit. See Appendix 1 for details of calculations.

Table 2: NHL prevalence in England and Wales at 31st December 2006^{16 a}

	1 year prevalence			5 year prevalence			10 year prevalence		
	England	Wales	England & Wales	England	Wales	England & Wales	England	Wales	England & Wales
NHL prevalence (2006)	6,330	498 ^b	6,761	24,207	1,516	25,723	38,227	2,224	40,451
Estimated FL prevalence (based on FLs as 20-30% of NHLs) ^{6,7,8,9}	1, 266-1,899	105 ^b	1,371 ^c -2,028	4,841-7,262	303-455	5,145-7,717	7,645-11,468	445-667	8,090-12,135

^a Prevalence data relates to the proportion of the UK population alive on 31st December 2006 having previously been diagnosed with cancer; ^b Data provided by the Welsh Cancer Intelligence & Surveillance Unit 2008;

^c Calculated using 1 year prevalence figure for Wales provided by the Welsh Cancer Intelligence & Surveillance Unit 2008.

The incidence of NHL has been increasing in the UK; rates have increased by more than a third since the late 1980s resulting in the incidence in people aged over 75 years being three times higher in 2007 than in 1975.¹⁷ Other countries (Western Europe, USA, Japan, Brazil, India and Singapore) have also noted increasing incidences of NHL. In westernised countries, the annual incidence of FL has increased from 2-3/100,000 during the 1950s to 5-7/100,000 recently (date not specified).¹⁸

It is unclear why the incidences of lymphomas are increasing, although better diagnosis, improved cancer reporting, changes in classification, unknown environmental factors, an increasing elderly population, and increases in AIDS-related lymphomas will contribute to the increase in incidence. However, these factors are estimated to account for about half of the increase in observed incidence.¹⁹

Aetiology

The causes of NHL in general, including FL, are unclear. There are a number of well-established risk factors, such as infectious agents (e.g. HIV),²⁰ immunosuppression (e.g. postorgan transplantation),²¹ genetic susceptibility (e.g. ataxia telangiectasia)²² and environmental factors (e.g. exposure to agrochemicals). Rare immunodeficiency conditions such as hypogammaglobulinemia, Wiskott-Aldrich syndrome and ataxia-telangiectasia have been associated with as much as a 25% increased risk of developing lymphoma;²⁴ however the primary causes of NHLs remain elusive.

Pathology

Background

NHLs are a diverse group of cancers characterised by abnormal growth of tissue in the lymphatic system. The lymphatic system comprises the tissues, organs and vessels that produce, store and deliver cells that fight infection, or 'lymphocytes'. There are two main classes of lymphocytes: T lymphocytes and B lymphocytes with each having a key role in protecting the body from pathogenic microorganisms. 'T-cells' are responsible both for cell-mediated immunity and for stimulating 'B-cells' which when activated produce antibody that kills or neutralises antigens. NHL may be classified as a B-cell or T-cell NHL, depending on whether it is B or T lymphocytes that are proliferating at an abnormal rate. Approximately 85% of all NHLs are of B-cell origin and the remaining 15% of T-cell origin.²⁵

FL is classified as a B-Cell NHL. It is an indolent (slow-growing) cancer that affects B-cell lymphocytes (centocytes and centroblasts). Patients with FL typically present with painless, swollen lymph nodes in the neck, armpit, or groin. Systemic or 'B' symptoms are rare; these include fever, fatigue, night sweats, and unexplained weight loss.^{5,26} Less frequently, there may be no peripheral lymphadenopathy, or patients develop abdominal or back pain due to intra-abdominal (often paraortic) lymph node enlargement.⁵ Usually disease is disseminated and involves lymph node regions on both sides of the diaphragm (stage III) or possibly extra-lymphatic organs or tissues (stage IV).^{6,27}

Despite being treatable, FL is characterised by a relapsing and remitting clinical course over several years, with each successive response becoming more difficult to achieve and of shorter duration.²⁶ The course and prognosis of FL improved only marginally from 1960 to the early 1990s, with a reported median survival of 8-10 years.²⁸ However, in the last decade, longer median survival has been reported and attributed to novel therapeutic strategies including chemoimmunotherapy (i.e. chemotherapy and rituximab) and radioimmunotherapy.^{14,15}

Patients with advanced stage III-IV lymphomas will eventually become resistant to chemotherapy and transform to high-grade or aggressive lymphomas such as diffuse large B-Cell lymphoma (DLBCL).^{28,29} Resistant disease or transformation into DLBCL is the usual cause of death for FL patients.²⁶ The risk of transformation to aggressive lymphoma is thought to be constant over time;²⁸ the annual risk of transformation has been estimated as 3% per year and the median survival after transformation has been reported as 1.7 years, although this figure comes from the pre-rituximab era.³⁰ It is not clear whether specific therapies can increase or decrease this risk.³¹

Diagnosis and Grading

The diagnosis of FL is confirmed by lymph node biopsy, which optimally requires review by an expert haematologist.³²

Staging

Once FL is identified, it is staged to find out how far the disease has spread. Staging tests determine which areas of the body are affected by FL, the number of lymph nodes affected, and whether other organs are affected such as the bone marrow or liver. The Ann Arbor system (see Appendix 2) is a clinical tool which was originally developed for Hodgkin's disease, but is also used for FL to determine the stage of the lymphoma. It classifies four stages of disease that reflect both the number of sites of involvement and the presence of disease above or below the diaphragm.³³ Each stage of disease is divided into two subsets of patients according to the presence (A) or absence (B) of systematic symptoms. Fever without other cause, night sweats and weight loss of more than 10% of body weight are considered systemic symptoms. The tests carried out for staging include blood tests, CT scan, bone marrow biopsy. Positron Emission Tomography (PET) scan may also be used, though is not routine in the UK. At most, 10–15% of FLs are detected at the early stage;³⁴ thus the majority present with advanced stage disease (Ann Arbor stage III-IV).

Grade

FL is a low grade or indolent B cell disease and is diagnosed according to the WHO Classification. Grade is determined by histology (i.e. by inspecting cells under the microscope) which looks at the number and size of abnormal cells taken from lymph node biopsies. The disease may be subdivided into Grades 1/2 (combined in the latest version of the WHO classification), grade 3a or 3b. These subdivisions of Grade 3 are based upon the presence of increasing numbers of more aggressive cells termed centroblasts. Grade 3b is treated in the same manner as the common high grade NHL, DLBCL. Grades 1/2 and 3a are managed as indolent forms. Each disease stage (Ann Arbor I-IV) can be assigned a grade (1-3a/b).

Systems of classification

FL is classified according to its morphology, immune-phenotype, genetics, and clinical features of neoplasms. Since the 1970s, various classification systems have been used to differentiate NHLs which have developed alongside an increasing understanding of the different cellular components of the lymphatic system that the cancer process affects.³⁵ It is useful to be familiar with previous classification systems in order to interpret the older literature for lymphomas with now outdated names. The third edition of the International Classification of Diseases-Oncology provides a guide for translation of previous classification systems into the present.³⁶

The earliest classification systems were based on the cellular morphology of neoplastic cells and their relationship to the lymphoid tissue architecture. The Rappaport Classification, which was used until the 70s, was devised before lymphoid cells were split into T and B cells.³⁷ In the early 1970s, the Kiel classification system was proposed, which classified lymphomas according to their cellular morphology and their relationship to cells of the normal peripheral lymphoid system.³⁸ The Working Formulation devised by the National Cancer Institute in 1982 attempted to translate the recognised classification systems for non-Hodgkin lymphoma (it did not include Hodgkin's lymphomas). The Working Formulation was a purely histological classification and divided lymphomas into four grades (Low, Intermediate, High, and Miscellaneous) related to prognosis, and included subdivisions based on the size and shape of affected cells. However, this classification system did not differentiate between T and B cells and is now obsolete.

With the development and application of immunophenotyping and cytogenetic and molecular genetic testing, the Revised European-American Lymphoma Classification (REAL) classification system was devised in the mid 1990s and incorporated immunophenotype and genetic criteria. The World Health Organisation (WHO) classification system, based upon the REAL classification, is the latest classification system and the most widely used and accepted. The WHO classification was updated in 2008 and groups lymphomas by cell type and defines phenotypic, molecular and cytogenetic characteristics. There are three large groups of neoplasms: 1) B cell, 2) T cell and 3) natural killer cell neoplasms. FL are grouped under the B cell type (ICD-O-3 codes: 9690/3, 9691/3, 9695/3 and 9698/3).

Prognosis

FL is only curable for a few patients, mainly those with localised or early stage disease (Ann Arbor I and II).³⁹ Most advanced stage patients respond to initial drug therapy and their symptoms go into remission. However, despite novel therapies and recent improvements in therapy, advanced FL is not considered curable. Advanced FL patients undergo multiple relapses with the duration of remissions shortening at each subsequent treatment at recurrence.^{29,40}

Prognostic factors

Prognostic factors in FL can be categorised as patient-related factors and disease-related factors. By analysing prognostic factors, indices have been developed to predict clinical outcomes such as progression-free survival (PFS) and overall survival (OS). Two such indices are the International Prognostic Index (IPI) and the Follicular Lymphoma International Prognostic Index (FLIPI).

Patient-related variables

The most important patient-related prognostic factors are performance status and age.⁴¹ Performance status, is defined by the Eastern Cooperative Oncology Group (ECOG)⁴² and ranges from 0 (fully

active) to 4 (completely disabled); thus poorer performance status is associated with a poorer FL prognosis (see Appendix 3 for ECOG performance status in detail). However, only 10-15% of FL patients present with a poor performance status at the time of diagnosis.⁴¹

Age greater than 60 years is a significant factor for prognosis.^{43,44} The existence of comorbidities and alterations in immunity with age might limit the drugs that can be used.⁴⁵ In addition, alterations in pharmacokinetics and reduction in hepatic and renal function occurs with increasing age. This affects the absorption, distribution, activation, metabolism and clearance of drugs.⁴⁵ This impacts upon the clinician's ability to treat elderly patients effectively. Gender has also been shown to be an important prognostic factor; the male sex is associated with a poorer clinical outcome.²⁷

Disease-related factors

Histological features such as lower degree of follicularity (i.e. greater diffuse areas),^{46,47,48,49} absence of interfollicular fibrosis⁴⁶ and high content of macrophages in biopsy samples⁵⁰ are associated with poor prognosis; helper T cell infiltrates have been associated with a survival benefit.^{51,52} Genetic features such as oncogenes or tumour suppressor genes, chromosomal gains or losses and gene expression profiles have been found to affect prognosis.⁴¹

Factors relating to disease extent are important in predicting prognosis. Patients with limited stage disease (i.e. Ann Arbor stage I or II) are likely to have prolonged survival.⁴¹ However, the majority of patients present with advanced disease (stage III or IV), thus the effect of other clinical parameters has been investigated. A larger number of extranodal sites involved,^{44,53,54,43} presence of B symptoms,^{43,53} the presence and greater extent of bone marrow involvement⁵⁵ and the presence of hepatosplenomegaly²⁹ have all been found to affect adversely prognosis. In addition, tumour burden has been identified as an important prognostic factor; however it is inconsistently defined according to size of lymph node masses, number of extranodal sites involved, degree of splenomegaly or hepatomegaly and the presence of circulating lymphoma cells.⁴¹

Biological markers such as elevated lactate dehydrogenase (LDH) have been found to predict lower response rates and survival.^{27,43,53} A normal haemoglobin level has been found to be a favourable factor for prognosis, whereas an haemoglobin level of <12mg/dl is a poor prognostic factor.²⁹

International Prognostic Index (IPI)

The IPI was originally designed as a prognostic tool for aggressive NHL (DLBCL), and is based on the presenting features and the extent of disease. The IPI has been reported to discriminate between FL patients with significantly different survival periods,⁵⁶ and is now used as a predictive tool for survival in FL see (Table 3).

Table 3: International Prognostic Index

One point is assigned for each of the following risk factors:	The sum of the points allotted correlates with the following risk groups:
<ul style="list-style-type: none"> • Age greater than 60 years • Ann Arbor stage III or IV disease • Elevated serum lactate dehydrogenase (LDH) • ECOG/Zubrod performance status of 2, 3, or 4 • More than 1 extranodal site 	<ul style="list-style-type: none"> • Low risk (0-1 points) - 5-year survival of 73% • Low-intermediate risk (2 points) - 5-year survival of 51% • High-intermediate risk (3 points) - 5-year survival of 43% • High risk (4-5 points) - 5-year survival of 26%

Follicular Lymphoma International Prognostic Index (FLIPI and FLIPI2)

In 2004, the FLIPI was developed specifically for patients with FL. Evaluations of demographic, clinical and biological characteristics from more than 4000 patients with FL were used in univariate and multivariate analyses to develop the FLIPI. It provides clinicians and patients with a prognostic index based on five criteria (age >60, Ann Arbor stage III or IV, number of nodal sites of involvement more than 4, elevated serum LDH, and haemoglobin level < 12gm/dl). The FLIPI assesses overall survival, i.e. carrying a low (0-1 risk factors), intermediate (2 risk factors), or high risk (3-5 risk factors).⁵⁷ The FLIPI has been further refined to accommodate more recent developments in the collection of biological data and newer treatment modalities such as immunotherapy, resulting in FLIPI2.⁵⁸ For example, β 2microglobulin is an independent prognostic marker included in later versions of the FLIPI.

Significance in terms of ill-health (burden of disease)

The nature of NHL in general and the relapsing/remitting course of FL in particular, suggest that both individually and at a population level it is responsible for a considerable amount of morbidity and mortality (see section 3.1.1). In 2009, NHL accounted for 0.8% of all deaths and 2.9% of all cancer deaths in England and Wales (see Appendix 4 for data sources and numbers used), and is the ninth most common cause of cancer mortality in the UK.²

3.2. Current service provision

Objectives of treatment and important health outcomes

Advanced FL is not curable. However, because of the age distribution and presence of co-morbidities, whilst patients may not be cured of FL, they may die from other causes unrelated to the disease. The aim of disease management is to both increase patient life expectancy and to increase patient health-related quality of life (HRQoL). First-line treatment aims to produce a maximum initial response by reducing tumour burden,⁵⁹ to prolong the periods of PFS and OS, to increase the duration between episodes of disease recurrence and to minimise the symptoms associated with relapse and treatment side effects.⁶⁰

Therefore, the following outcomes are likely to be of potential importance:

- absence of disease at given points in time following diagnosis
- absence of symptoms
- absence of side effects
- duration of survival
 - overall survival
 - progression-free survival
- HRQoL
- patient and carer satisfaction

Management of disease

Grading, staging and symptoms determine treatment pathways. Figure 1 gives an overview of the treatment pathway for Stage III/IV FL (adapted from the manufacturer's submission (MS) for this appraisal).⁶¹ This pathway has been simplified and does not take into account the risk of transformation to DLBCL or the differences in treatment of disease which relapses early compared with later relapse. These are discussed later in this section.

Figure 1: Treatment pathway for stage III/IV FL (adapted from MS)⁶¹

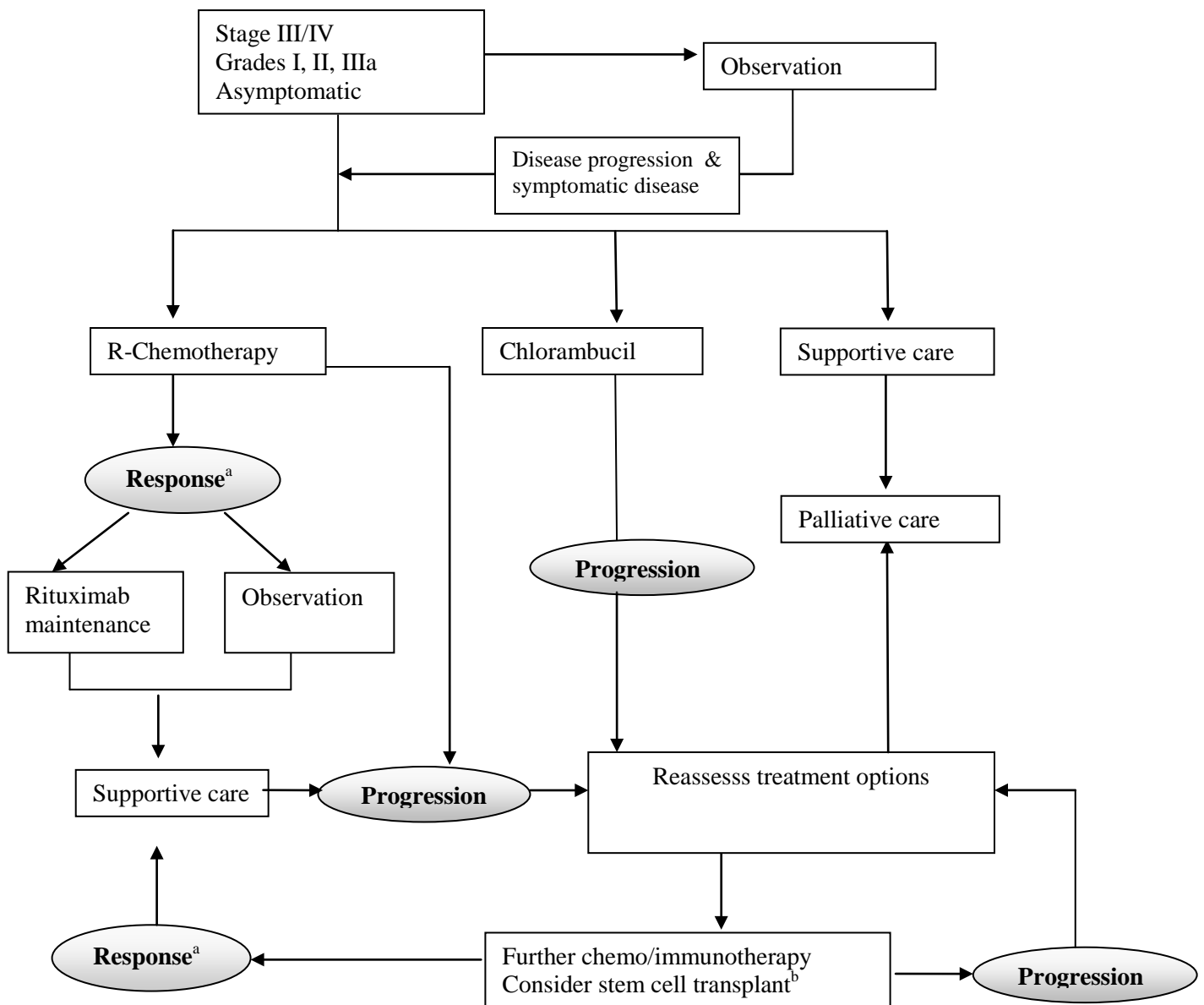

^a Response can be complete or partial response; ^b Note that patients who received chlorambucil in first-line treatment would not be eligible to receive stem cell transplant

Asymptomatic patients

Most patients are asymptomatic on presentation (painless swelling of one or more lymph nodes) and a ‘watch and wait’ approach is usually adopted. Observational studies^{62,63} and three RCTs^{64,65,66} have shown that prognosis is not affected by immediate treatment versus observation until symptomatic disease progression (bulky lymphadenopathy, bone marrow compromise, splenomegaly etc.). Thus, treatment only commences when the disease becomes symptomatic.

First-line therapy: limited disease (Ann Arbor stages I–II)

Patients diagnosed in the early stages of the disease (stages I-II) usually respond well to radiotherapy and this is the treatment of choice, usually taking the form of extended or involved field form irradiation. This can result in long term disease free survival and possible cure for between 45–80% patients.³⁴

First-line therapy: advanced disease (Ann Arbor stages III–IV)

Chemoimmunotherapy (i.e. rituximab and chemotherapy) is the preferred treatment for first-line therapy in symptomatic advanced FL. The European Society for Medical Oncology (ESMO) clinical practice guidelines recommend that where complete remission and long progression-free survival are the aims of treatment, rituximab in combination with chemotherapy (such as CHOP, CVP, FC, FM or bendamustine) should be used.¹⁸ The current NICE guidance states that rituximab in combination with CVP is indicated for the first-line treatment of symptomatic FL, in line with the licensed indication at the time the guidance was issued. However, in 2008, the license for rituximab was broadened so that it can be administered with other chemotherapies; there is however no consensus on the preferred chemotherapy option.⁶⁷ Antibody monotherapy or single agent alkylating agents (e.g. chlorambucil) can be considered an alternative in previously untreated FL patients with particularly low risk disease, or those unsuitable for more intensive treatments.¹⁸

Maintenance therapy (first-line)

As disease recurrence is inevitable, ways of maintaining or improving the quality of the initial response to treatment are used, such as maintenance therapy. Maintenance treatment is a long-term approach that aims to delay relapse by stabilising the best response to initial therapy, eradicating any residual disease and maintaining remission after successful remission induction therapy.⁶⁸

The ESMO clinical practice guidelines acknowledge recent evidence that rituximab maintenance for two years can prolong progression-free survival.⁶⁹ The licence for rituximab maintenance in first-line treatment was issued only recently (25th October 2010) and is being considered in an ongoing NICE technology appraisal as of April 2011. Prior to this, the UK standard practice has been to closely observe patients during their first remission and re-treat only when there is evidence of disease progression.

Aside from rituximab, other agents have been proposed for use as maintenance therapy such as interferon- α (a biological therapy). However, a meta-analysis suggests a limited benefit of interferon- α maintenance therapy that has to be balanced against toxicity.⁵ Clinical advice suggests interferon is not used as patients cannot tolerate the side effects.

Consolidation therapy is another type of treatment that has been proposed following successful induction of first-line remission. Consolidation therapy is delivered immediately after a response to induction therapy, however it differs from maintenance therapy as it is a short course of treatment which aims to rapidly improve the response to induction therapy.⁵⁹ Radioimmunotherapy agents such as Zevalin[®] (Spectrum Pharmaceuticals) have been used in consolidation therapy; however their benefit following a rituximab and chemotherapy combination has not been established.¹⁸

Treatment of relapsed disease

Following every relapse, a biopsy should be undertaken to determine if transformation has occurred.^{5,18} When transformation does occur, there is usually rapidly increasing lymph node enlargement, elevated LDH levels and development of systematic symptoms. Histological transformation can occur in 20-70% of patients; the variability in reported incidence to a large extent reflecting local practice in terms of whether biopsies are performed at each recurrence.⁵ Treatments for FL are not effective once transformation has occurred and patients are treated as for high grade FL or DLBCL. Median survival following transformation has been reported as 18 months, although this figure comes from the pre-rituximab era.⁵

When the disease has relapsed, treatment options are reassessed, with the selection of salvage treatment depending on the efficacy of prior regimens.¹⁸ However, there may be some variations between clinical practice in the UK and the ESMO guidelines.

When there is early relapse following first-line rituximab-chemotherapy treatment (<6 months), the disease is considered as rituximab-refractory in the ESMO guidelines which state that rituximab is not indicated. However, clinical advice to the Assessment Group (AG) indicated that some clinicians may also consider which chemotherapeutic regimen was given in first-line treatment when choosing the second-line treatment. For example, if R-CVP had been used in first-line induction therapy and early relapse occurred, R-CHOP may be selected for the second-line treatment with the rationale being that it was the CVP-component rather than the rituximab that was responsible for the early relapse. If, however R-CHOP had been used in first-line induction therapy, and relapse is early, this is indicative of a poor prognosis (based on clinical advice sought by the AG), making high dose chemotherapy (with or without rituximab) and stem cell transplant an appropriate second-line treatment.

The ESMO guidelines also state that in relapses <12 months, a non-cross-resistant scheme should be preferred with regard to the chemotherapy selected (i.e. two differing chemotherapeutic regimens such as fludarabine after CHOP for example). Rituximab monotherapy is also recommended as a treatment option by NICE for people with relapsed or refractory disease when all alternative treatment options have been exhausted.⁷⁰

The use of rituximab in re-treatment of patients who have received rituximab at first-line treatment has been discussed previously in NICE technology appraisal (TA137), where evidence for clinical effectiveness of rituximab in second-line treatment of FL was from the EORTC 20981 trial^{71,72} whose population were rituximab-naive patients. However, whilst the Committee considered that “it was necessary to be cautious about the assumption that rituximab is as efficacious in patients who had already received it as in patients who are rituximab-naive”; clinical specialists present at the Committee stated that “the evidence indicated that follicular non-Hodgkin's Lymphoma could be re-treated with rituximab with little or no loss of efficacy.” It was noted by the Committee that although this is as an area of uncertainty, this was biologically plausible given rituximab's mechanism of action.⁷⁰ This is discussed in more detail in section 6.4.1 (p.146)

Second-line rituximab maintenance

Following response to second-line induction therapy (with or without rituximab), rituximab monotherapy may also given as second-line maintenance as recommended by NICE.⁷⁰

Stem cell transplant

During the course of treatment, relapses become more frequent with shorter progression-free survival periods,⁶⁷ and chemotherapy or chemoimmunotherapy are not able to induce a further stable remission period. Stem cell transplant (SCT) is a treatment option for relapsed FL patients. However, the use of and position of stem cell transplant (SCT) in the treatment pathway of FL has altered since the introduction of rituximab; and the ESMO guidelines state that its use needs to be re-evaluated in the rituximab era.¹⁸ Clinical advice provided to the AG suggests its use has declined in the treatment of FL since the introduction of rituximab in first-line induction and maintenance, and second-line induction and maintenance. In second-line treatment, SCT appears to be reserved for patients with very aggressive disease and short remission periods following first-line induction therapy or patients who have undergone transformation to DLCL. For patients who do not have aggressive disease and for whom a reasonable remission period has been achieved following first-line treatment, SCT is considered more frequently at the third-line treatment stage. At whichever point SCT is offered in the treatment pathway, it is usually only offered to younger patients (<65 years), although clinical advice suggests that it may be offered to some fit patients up to 70 years of age.

Relevant national guidelines

A summary of the relevant EMEA licensing and NICE guidelines relating to the use of rituximab in the treatment of FL is presented in Table 4.

Table 4: Relevant NICE guidance for the treatment of advanced FL

Stage of disease	Treatment	Licensed by EMEA	Recommendation by NICE	Conditions of NICE recommendation
First-line induction	R-CVP	✓	✓	Previously untreated patients Symptomatic patients
First-line induction	R-Chemotherapy ^a	✓	X Considered in this assessment report	Not applicable
First-line maintenance	R-monotherapy	✓	X Ongoing technology appraisal	Being appraised: Only for responders to first-line induction therapy with rituximab in combination with chemotherapy.
Second-line induction	R-Chemotherapy ^a R-monotherapy	✓	✓	R-monotherapy only when all alternative treatment options have been exhausted (that is, if there is resistance to or intolerance of chemotherapy).
Second-line maintenance	R-monotherapy	✓	✓	Only for responders to second-line induction therapy of rituximab or R-chemotherapy

^a Chemotherapy can be any regimen; R= rituximab

The ESMO has produced guidelines for the diagnosis, treatment and follow-up of newly diagnosed and relapsed FL¹⁸ as discussed in the section 3.2: management of disease. The British Committee for Standards in Haematology (BCSH) has produced guidelines on the diagnosis and reporting of NHLs^{73,74} from BCSH website). Guidance specific to FL is due for publication in August 2011. Archived guidance from the BCSH exists on the diagnosis and therapy for nodal non-Hodgkin's lymphoma.²⁶

Variation in services and/or uncertainty about best practice

Whilst rituximab and chemotherapy is the preferred treatment for first-line therapy in symptomatic advanced FL, there is no consensus on the preferred chemotherapy.⁶⁷ No direct trials have been undertaken that compare one R-chemotherapy regimen with another R-chemotherapy regimen; although there are four ongoing phase III RCTs comparing one or more R-chemotherapy regimens against another R-chemotherapy^{75,76,77,78} (see section 5.2 for further details of ongoing trials). Siddhartha *et al.*⁷⁹ conducted a meta-analysis to compare R-CHOP versus R-CVP with respect to response rates (two separate analyses were provided for first-line treatment only and first-line and relapsed treatment) and differences were noted in the quality of the responses achieved. A greater proportion of complete responders were observed following R-CVP than R-CHOP. However, overall response rate was better following the R-CHOP regimen (due to more partial responses). It is difficult to know if there is a different effect in quality of response to R-CVP or R-CHOP; however clinical advice to the AG noted that R-CHOP is more likely given to patients with bulky or more aggressive disease who are more likely to achieve a partial than complete response.

However, treatment/efficacy outcomes are not the only factors to consider when choosing chemotherapy. Clinical advice suggests that elderly patients or patients with co-morbidities, particularly cardiac problems are less likely to receive CHOP, as it is an anthracycline-based chemotherapy. In addition, where SCT is a potential future treatment, the chemotherapeutic agent selected must not interfere with the potential to harvest stem cells. Thus, in SCT candidates, fludarabine, a purine analogue therapy, is to be avoided as these can compromise the quality of the stem cell harvests.

The manufacturer sought clinical guidance from two clinicians whose responses also reflected the need for an individualised choice of chemotherapeutic agent in patients.⁶¹ In addition, they also highlighted other important factors in treatment selection including patient choice (e.g. acceptability of alopecia which is higher after CHOP, and side effects tolerance) and the need to obtain a rapid response if a compression syndrome is present (e.g. deep vein thrombosis, leg oedema).

Current usage in the NHS

Figures reported in the MS⁶¹ from an unpublished survey of UK haemato-oncologists (n=50) suggest approximately 92% of all eligible previously untreated stage III-IV FL patients in the UK currently receive rituximab in combination with chemotherapy as standard treatment (These data were made available by the manufacturer to the AG).⁶¹ The remaining 8% receive single agent chlorambucil, FM, Bexxar (a radiolabelled monoclonal antibody) or alternative chemotherapy. Of the patients receiving a rituximab containing regimen, approximately 67% are treated with rituximab plus CVP and a further 16% are treated with R-CHOP. The remainder receive rituximab combined with other chemotherapies which includes R-chlorambucil, R-FC, R-FCM and R-F.⁶¹ The AG requested access to the survey data from Roche and the results are presented in Table 5.

Table 5: Survey results (patients N=120) for the first-line treatment of untreated stage III-IVFL in the UK⁶¹

Treatment	Number	Percentage
R-CVP	80	67
CVP	1	1
R-CHOP	19	16
Chlorambucil	6	5
R-C	4	3
R-FC	5	4
FM	1	1
R-FM	1	1
R-F	1	1
Bexxar	1	1
Alternative chemo	1	1

R-CVP= rituximab, cyclophosphamide, vincristine and prednisolone; CVP= cyclophosphamide, vincristine and prednisolone; R-CHOP= rituximab, cyclophosphamide, doxorubicin, vincristine and prednisolone; R-C= rituximab and chlorambucil; R-FC= rituximab, fludarabine and chlorambucil; FM=fludarabine and mitoxantrone; R-FM= rituximab, fludarabine and mitoxantrone; R-F= rituximab and fludarabine.

Clinical advice sought by the AG suggests that this seems a reasonable estimate indicating the great majority of patients receive a rituximab-chemotherapy. Chlorambucil as a single agent chemotherapy regimen is reserved only for patients deemed too unfit or unwell for a rituximab-chemotherapy regimen. The proportions of R-CHOP and R-CVP administered are difficult to quantify according to clinical advice; historically R-CVP has been the first choice chemotherapy arm, however R-CHOP is the international standard. However, at present R-CHOP is not currently recommended by NICE, which is likely to affect its current uptake within the UK. Clinical advice suggests that the use of other

chemotherapy regimens in combination with rituximab such as R-MCP (rituximab, mitoxantrone, chlorambucil and prednisolone), R-CNOP (rituximab, cyclophosphamide, mitoxantrone, vincristine and prednisolone), R-CHVP (cyclophosphamide, doxorubicin, etoposide, and prednisolone), R-FCM, R-FM, R-F and R-C is very infrequent within the NHS.

Current service cost

Because treatment of FL is part of general haematological or oncology services, the cost of caring for this group of patients is very difficult to derive from the routine financial information available for the NHS. However, consideration of the variety of treatments to which an individual might be exposed during the course of their illness suggests that the costs of caring for FL are likely to be considerable. In this, the support required from both primary and palliative care services in the terminal stages of the disease should not be underestimated.

Significance for the NHS

Rituximab with cyclophosphamide, vincristine and prednisolone (CVP) is currently recommended by NICE for the first-line treatment of FL.⁸⁰ Thus, given the number of patients with FL, the introduction of rituximab with other chemotherapies would incur costs. However, neither new equipment nor intensive training would be required.

3.3. Description of technology under assessment

Identification of patients and important subgroups

Rituximab (Mabthera[®], Roche Products) in combination with chemotherapy is considered as a possible option for the treatment of symptomatic stage III-IV FL.

Place in treatment pathway

This assessment report is concerned with the use of rituximab and chemotherapy as first-line induction treatment. However, rituximab with or without chemotherapy is recommended by NICE at other points within the treatment pathway and these impact upon the cost-effectiveness of R-chemotherapy in first-line induction therapy (see Table 4 for NICE recommendations of rituximab).

Therapeutic classification

Rituximab is a genetically engineered 'monoclonal antibody' that has been designed to recognise an antigen/surface marker on B-lymphocytes called CD-20. Monoclonal antibodies are produced by fusing single antibody-forming cells (generated in laboratory mice) to tumour cells (grown in culture) producing large quantities of identical antibody molecules from a single, cloned antibody producing cell, hence the name 'monoclonal antibodies'.³⁵

The CD20 surface marker/antigen is present on the surface of B-lymphocytes in more than 90% of NHLs.⁸¹ When rituximab attaches to the antigen, this causes cell death,^{82,83} so that cancerous and normal B-lymphocytes are destroyed. Whilst fully developed B lymphoma cells have CD20 on their surface, early B cells don't have the CD20 protein and are not killed.

Brand and generic name

Rituximab is the generic name; Roche's brand name is MabThera[®]. Rituximab is also known as IDEC-C2B8 and Rituxan.⁸⁴

Dosage form and route

Rituximab is sold as a concentrate for solution for intravenous infusion. A 10ml single use vial is available and contains 100mg of rituximab (sold in packs x2 vials).⁸² A 50ml single use vial is also available (500mg/50ml).

Method of administration

Premedication with glucocorticoids should be considered if rituximab is not given in combination with glucocorticoid-containing chemotherapy. Premedication consisting of an anti-pyretic and an antihistaminic, e.g. paracetamol and diphenhydramine, should always be administered before each infusion of rituximab.⁸²

First infusion

The recommended initial rate for infusion is 50 mg/hr; after the first 30 minutes, it can be escalated in 50 mg/hr increments every 30 minutes, to a maximum of 400 mg/hr.⁸²

Subsequent infusions

Subsequent doses of rituximab can be infused at an initial rate of 100 mg/hr, and increased by 100 mg/hr increments at 30 minutes intervals, to a maximum of 400 mg/hr.⁸² The prepared rituximab solution should be administered as an intravenous infusion through a dedicated line. It should not be administered as an intravenous push or bolus.⁸²

Licensed indications

Rituximab is licensed for the treatment of previously untreated patients with stage III-IV FL in combination with chemotherapy. This current license was issued in January 2008 and does not restrict the type of chemotherapy. The original license agreement restricted use of rituximab in combination with CVP only and this is reflected in the existing NICE guidance.⁸⁰

Rituximab is also licensed for treatment of FL at other stages within the treatment pathway, other types of NHL, and has indications for treatment of chronic lymphocytic leukaemia and rheumatoid arthritis. The indications for use in FL and NHL are included below for completeness:

- Rituximab maintenance therapy is indicated for patients with relapsed/refractory FL responding to induction therapy with chemotherapy with or without rituximab.
- Rituximab monotherapy is indicated for treatment of patients with stage III-IV FL who are chemoresistant or are in their second or subsequent relapse after chemotherapy.
- Rituximab is indicated for the treatment of patients with CD20 positive DLBCL in combination with CHOP.

Contraindications

Rituximab is contraindicated for use in NHL in patients who have known hypersensitivity to the active substance or to any of the excipients or to murine proteins, in active severe infections or in patients in a severely immunocompromised state.⁸²

Warnings

Infusion reactions

Infusion-related side effects (including cytokine release syndrome) are reported commonly with rituximab and predominantly occur during the first infusion and include symptoms such as fever and chills, nausea and vomiting, allergic reactions (such as rash, pruritus, angioedema, bronchospasm and dyspnoea), flushing and tumour pain.⁸⁴ Mild or moderate infusion-related reactions usually respond to a reduction in the rate of infusion, which can be increased upon improvement of symptoms. Patients who develop severe reactions, especially severe dyspnoea, bronchospasm or hypoxia should have the infusion interrupted immediately.⁸²

Before each dose of rituximab, patients should be given an analgesic and an antihistamine to reduce these effects and consideration should be given to premedication with a corticosteroid. In all patients, the infusion should not be restarted until symptoms have resolved and laboratory values and chest x-rays appear normal. Patients who have experienced severe cytokine release syndrome should be closely monitored as although they may show an improvement in symptoms, this may be followed by deterioration. Thus such patients must be evaluated for evidence of tumour lysis syndrome and pulmonary infiltrations with a chest x-ray

Fatalities following severe cytokine release syndrome (characterised by severe dyspnoea) and associated with features of tumour lysis syndrome have occurred 1–2 hours after infusion of rituximab. Patients with a high tumour burden and those with pulmonary insufficiency or infiltration are at increased risk and should be monitored very closely.⁸⁴

Anaphylactic and other hypersensitivity reactions have been reported following the intravenous administration of proteins to patients. Clinical manifestations of anaphylaxis may appear similar to clinical manifestations of the cytokine release syndrome. However, in contrast to cytokine release syndrome, true hypersensitivity reactions typically occur within minutes after starting infusion.⁸²

Pregnancy and lactation

Rituximab should be avoided during pregnancy unless the potential benefit to the mother outweighs risk of B-lymphocyte depletion in the foetus. It is also contraindicated in women who are breast-feeding. Effective contraception is required during treatment and for 12 months after treatment.⁸⁴

Cardiovascular disease

Rituximab should be used with caution in patients receiving cardiotoxic chemotherapy or with a history of cardiovascular disease because exacerbation of angina, arrhythmia and heart failure have been reported. Transient hypotension occurs frequently during infusion and antihypertensives may need to be withheld for 12 hours before infusion.⁸⁴

Infections

Serious infections, including fatalities, can occur during therapy with rituximab. Physicians should exercise caution when considering the use of rituximab in patients with a history of recurring or chronic infections or with underlying conditions which may further predispose patients to serious infection.⁸²

Personnel involved

Treatment should be undertaken under close supervision of a specialist.⁸⁴ The delivery of rituximab requires no additional personnel to the administration of chemotherapy, namely a senior clinician (specialist registrar or above), a specialist nurse and a specialist pharmacist.

Setting

Outpatients would receive intravenous transfusion in the same chemotherapy suite as would be used for the administration of chemotherapy.

Equipment required

Full resuscitation equipment should be at hand.⁸⁴ The intervention would require no equipment outside of that normally associated with a chemotherapy suite. Some clinics advise that rituximab is infused while the patient is on a bed, rather than in a chair.

Length of treatment

Each service user would expect to receive one treatment on day one of each cycle, every 3 weeks, for up to eight cycles; in other words, eight intravenous days (4–6 hours each) at the chemotherapy suite, over the course of 24 weeks.

Follow-up required

The ESMO guidelines suggest follow-up treatment both during and after treatment. However, clinical advice to the AG suggests that follow-up differs in UK clinical practice, particularly with regard to the frequency of cross-sectional imaging which is not undertaken routinely in the absence of clinical suspicion of progression. Clinical advice to the AG advised that the new BCSH guidelines⁸⁵ scheduled for publication in June 2011 specifically states that routine scans are not recommended.

During treatment, the ESMO guidelines state that “adequate radiological tests should be performed mid-term and after completion of chemotherapy”. Where an insufficient or no response is found, patients should be evaluated for early salvage regimens. The ESMO guidelines¹⁸ suggest the following as follow-up after treatment; however it is noted that clinical advice does not agree with the frequency of imaging:

- History and physical examination every 3 months for 2 years, every 4–6 months for 3 additional years, and subsequently twice a year with special attention to transformation and secondary malignancies including secondary leukaemia.
- Blood count and routine chemistry every 6 months for 2 years, then only as needed for evaluation of suspicious symptoms.
- Evaluation of thyroid function in patients with irradiation of the neck at 1, 2 and 5 years.
- Minimal adequate radiological or ultrasound examinations every 6 months for 2 years and annually thereafter. (Note that this is not recommended by the clinical advice sought by the AG).

Anticipated costs associated with intervention

The recommended dose of rituximab is 375mg/m², and the net price for a 10-ml vial is £174.63 and for a 50-ml vial is £873.15.⁸⁴

4. DEFINITION OF THE DECISION PROBLEM

4.1 Decision problem

Intervention

Rituximab (Mabthera[®]) is indicated for the treatment of previously untreated patients with stage III-IV FL in combination with chemotherapy at a recommended dose of 375 mg/m² body surface area per cycle, for up to 8 cycles. This assessment includes interventions where rituximab is given in combination with the following chemotherapy regimens:

- **CVP:** cyclophosphamide, vincristine and prednisolone
- **CHOP:** cyclophosphamide, doxorubicin, vincristine and prednisolone
- **CNOP:** cyclophosphamide, mitoxantrone, vincristine and prednisolone
- **CHVP:** cyclophosphamide, doxorubicin, vindesine, prednisolone
- **MCP:** mitoxantrone, chlorambucil, and prednisolone
- **FCM:** fludarabine, cyclophosphamide and mitoxantrone
- **FM:** fludarabine and mitoxantrone
- Bendamustine
- Fludarabine
- Chlorambucil

When this appraisal started, bendamustine was not currently licensed as a first-line treatment with rituximab for first-line treatment of FL. However, as the anticipated date of licensing was not known and could occur within the time scales of the appraisal, bendamustine was included as a combination chemotherapy agent (with rituximab). At the time of writing, bendamustine remains unlicensed for use in this population for the first-line treatment indication.

Population including sub-groups

The population comprised adults with symptomatic stage III-IV FL (a Non-Hodgkin's lymphoma) who have not received any previous treatment. Indolent FL is considered within this appraisal. Where data is presented for elderly FL patients (> 65 years or older), these will be examined as a subgroup.

Relevant comparators

Non-rituximab containing chemotherapies are the relevant comparators, and for this assessment the following comparators are considered:

- **CVP:** cyclophosphamide, vincristine and prednisolone
- **CHOP:** cyclophosphamide, doxorubicin, vincristine and prednisolone
- **CNOP:** cyclophosphamide, mitoxantrone, vincristine and prednisolone
- **CHVP:** cyclophosphamide, doxorubicin, vindesine, prednisolone
- **MCP:** mitoxantrone, chlorambucil, and prednisolone
- **FCM:** fludarabine, cyclophosphamide and mitoxantrone
- **FM:** fludarabine and mitoxantrone
- Bendamustine
- Fludarabine
- Chlorambucil

Outcomes

The outcomes considered in this appraisal mostly relate to clinical and cost-effectiveness and include:

- overall survival
- progression free survival
- response rates
- duration of disease remission/response duration
- adverse effects of treatment
- health related quality of life

4.2 Overall aims and objectives of assessment

This assessment will address the question: “What is the clinical and cost-effectiveness of rituximab (in its licensed indication) with chemotherapy for the first-line treatment of symptomatic stage III-IV FL.”

The aim of this review is to systematically evaluate and appraise the clinical and cost-effectiveness of rituximab (in its licensed indication) in combination with chemotherapy compared with non-rituximab containing chemotherapy, for the first-line treatment of symptomatic stage III-IV FL. Note that due to the scope specifying the intervention as *rituximab given in combination with chemotherapy*, interventions including rituximab in combination with other treatments such as radio-immunotherapy or bone marrow/stem cell transplant are not considered as an intervention for this appraisal.

5. ASSESSMENT OF CLINICAL EFFECTIVENESS

5.1 Methods for reviewing effectiveness

This systematic review was carried out according to the recommendations of the Preferred Reporting Items for Systematic Reviews and Meta-Analyses (PRISMA) statement.⁸⁶

5.1.1 Identification of studies

Search strategy

The search aimed to systematically identify all literature relating to the clinical-effectiveness of i) the intervention: rituximab in combination with chemotherapy or ii) the comparators i.e. chemotherapy alone for the treatment of FL. The searches were conducted in September and October 2010.

Sources searched

Eleven electronic databases were searched from inception: MEDLINE including Medline in process (Ovid); CINAHL; EMBASE; The Cochrane Library including the Cochrane Database of Systematic Reviews, Cochrane Controlled Trials Register (CENTRAL), DARE, NHS EED and HTA databases; Science Citation Index (SCI); BIOSIS.

Ongoing research was searched using clinical trials databases and registers including: NIHR Clinical Research Network Portfolio; National Research Register (NRR) archive 2000-2007; Current Controlled Trials and Clinical Trials.gov.

Relevant conference proceedings were searched, including the American Society of Clinical Oncology (ASCO), European Society of Clinical Oncology (ESCO), American Society of Hematology (ASH), the British Society for Haematology (BSH) and the European Hematology Association (EHA).

In addition, the reference list of relevant articles and the MS⁶¹ was handsearched. The review team also contacted experts in the field and scrutinised the bibliographies of retrieved papers to identify relevant evidence.

Search terms

A combination of free-text and thesaurus terms were used. 'Intervention' terms (e.g. rituximab, MabThera, Rituxan,) or chemotherapy terms (CHOP, CVP etc) were combined with 'population' search terms (e.g. lymphoma, non-Hodgkin's). Copies of the search strategies used in MEDLINE are included in Appendix 5 (these were adapted for use in other databases).

Search restrictions

Searches were not restricted by language or publication date. Where possible, a filter was applied in order to limit search results to systematic reviews/meta-analyses, economic/cost evaluations, quality of life studies or randomised controlled trials. Examples of the randomised controlled trial (RCT) filter, cost effectiveness filter and quality of life filter are provided in Appendix 5.

5.1.2 Inclusion and exclusion criteria

Study design

According to the accepted hierarchy of evidence, RCTs were included for the clinical effectiveness review, as they provide the most authoritative form of evidence. In the event of insufficient data available from RCTs, it was planned that observational studies or clinical trials would be considered; however this was not required in this review.

Intervention(s)

Rituximab in combination with any of the following chemotherapy regimens: CVP, CHOP, CNOP, CHVP, MCP, FCM, FM, bendamustine, fludarabine or chlorambucil.

Comparator(s)

The comparator was chemotherapy without rituximab, which for this review was considered to be one of the following: CVP, CHOP, CNOP, CHVP, MCP, FCM, FM, bendamustine, fludarabine or chlorambucil.

Potential for a network meta-analysis

The literature search was undertaken to allow identification of trials involving either an intervention or comparator defined in the decision problem as it was anticipated that the work may require a network meta-analysis to be undertaken to determine efficacy. It was planned to populate such an analysis with all identified trials involving either an intervention or a comparator. Whilst it is noted that the network meta-analysis could potentially be strengthened by the inclusion of RCTs involving two pharmaceuticals that were neither interventions nor comparators (provided there were RCTs comparing these pharmaceuticals with an intervention or a comparator), literature searches for all RCTs from these pharmaceuticals were not conducted as they are likely to have little impact on the results of interest and would have significant resource implications. In addition, where the evidence allowed, interventions were planned to be compared against each other.

Population

The population comprised adults with symptomatic stage III-IV FL who had not received any previous treatment.

Outcomes

The primary outcome of interest for this appraisal in relation to clinical effectiveness was overall survival. Secondary outcomes were progression-free survival, response rates (complete, partial and overall), duration of disease remission/response duration and adverse/toxic effects of treatment.

Overall survival was defined and calculated as the time from randomisation to the date of death by any cause. Progression free survival was defined and calculated as the time from randomisation to disease progression or death. Response rate was defined in the terms laid down by Cheson *et al.*⁸⁷ (see Appendix 6). Overall response rate combined complete and partial responders. Unconfirmed complete responses (CRu) were considered as partial responses so that the complete response (CR) and partial response (PR) rates were comparable between studies. However, it is noted this may result in an underestimation of CR since clinical advice suggests that CRus are more likely to follow a similar clinical course to CRs. Duration of disease remission/response duration was taken as the time from response achieved (CR or PR) to disease progression or death. Adverse events were defined as any adverse change from the patient's baseline condition, including intercurrent illness that occurred during the course of the clinical trial after the start of treatment, whether or not considered related to trial treatment. Health related quality of life was also considered as a secondary outcome.

Exclusion criteria

Reviews of primary studies were not included in the analysis, but were retained for discussion and identification of additional trials. Studies which were considered methodologically unsound were excluded from the review as well as the following publication types: non-randomised studies; animal models; preclinical and biological studies; narrative reviews, editorials, opinions; non-English language papers and reports where insufficient methodological details are reported to allow critical appraisal of study quality. In addition, although not stated in the protocol, studies which included populations other than those described above or studies that included NHL populations but did not provide outcome data separately for FL patients were excluded.

Study selection

Studies were selected for inclusion through a two-stage process according to the above inclusion/exclusion criteria. Titles and abstracts were examined for inclusion by one reviewer. Screening was checked by a second reviewer on ten percent of citations. The kappa coefficient (range 0 to 1) calculated to measure inter-rater reliability was good, approaching very good at 0.79. Discrepancies were resolved by discussion between the two reviewers when necessary, and did not require involvement of a third reviewer. Full manuscripts of selected citations were retrieved and assessed by one reviewer against the inclusion/exclusion criteria.

Data extraction strategy

Data was extracted by one reviewer using a standardised data extraction form and checked by a second reviewer. Discrepancies were resolved by discussion and did not require input from a third reviewer. Where multiple publications of the same study were identified, data was extracted and reported as a single study.

Critical appraisal strategy

The methodological quality of each included study was assessed by one reviewer and checked by a second reviewer, according to criteria based on those proposed by the NHS Centre for Reviews and Dissemination for RCTs.⁸⁸

The following factors were considered: method of randomisation, allocation concealment, blinding of patients, outcome assessors and data-analysts, numbers of participants randomised, baseline comparability between groups, specification of eligibility criteria, whether intent to treat analysis was performed, completeness of follow up and whether study power calculations were performed and reported.

Methods of data synthesis

Data was tabulated and discussed in a narrative review. Exploratory meta-analyses were performed to estimate a summary measure of the effect of response rates (overall, complete and partial) based on intention to treat analyses. Unconfirmed complete responses (CRu) were considered as partial responses in the meta-analyses so that the CR and PR rates were comparable between studies. However, it is noted this may result in an underestimation of CR since clinical advice suggests that CRus are more likely to follow a similar clinical course to CRs. Heterogeneity in these analyses was explored through consideration of the study populations, methods and interventions, by visualisation of results and, in statistical terms, by the χ^2 test for homogeneity and the I^2 statistic. Meta-analysis was carried out using random effects models, using the Cochrane Collaboration Review Manager[®] Software (version 5.0).⁸⁹

Meta-analysis was not performed for the outcome of progression-free survival as only one study was identified measuring this outcome. Meta-analysis was not performed for the outcome of overall survival because of problems with the data in three of the trials. The population in two studies were given subsequent treatment as part of the study intervention. The GLSG-2000 trial^{90,91} randomised responders who were <60 year old to receive either interferon maintenance or dose escalation chemotherapy and stem cell transplant; >60 year old responders were given interferon maintenance therapy. Responders in the OSHO-39 trial⁹² were all given interferon maintenance therapy. Thus, the subsequent maintenance therapy confounds the overall survival data. The population in the FL2000

trial⁹³ included 10% Stage II FL patients and included the biological therapy interferon as part of the six-month induction treatment phase and as a consolidation treatment for a further 12 months.

Other time to event data were presented in the included studies such as event-free survival, disease-free survival, time to progression. No meta-analyses were performed on these additional time to event outcomes due to inconsistencies in the way the outcomes were defined. These issues are discussed in more detail in section 5.2. A network meta-analysis was not carried out. The reasons for this are discussed in section 5.2.1

Figure 2: PRISMA (adapted) Flow Diagram

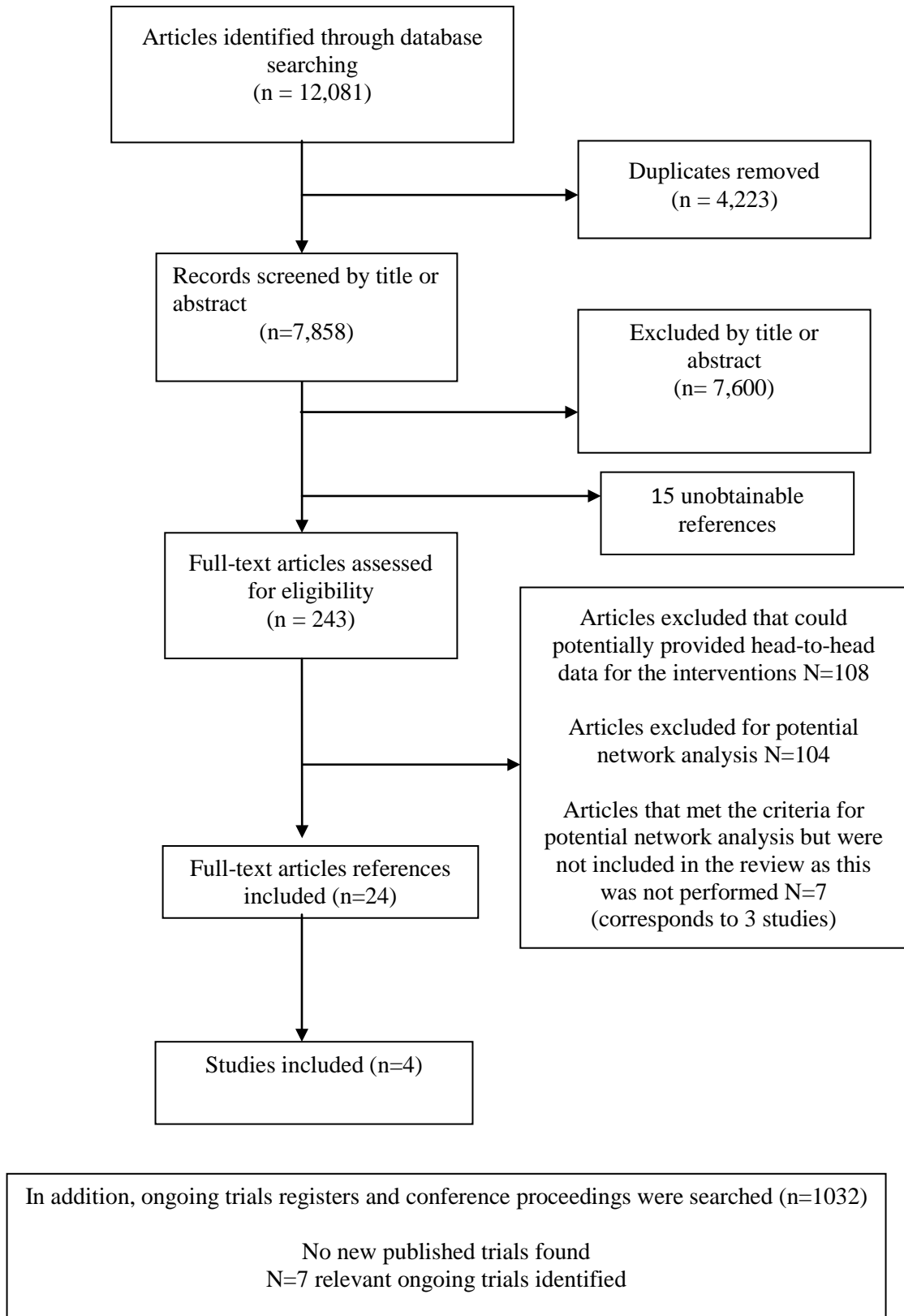

5.2 Results

5.2.1 Quantity and quality of research available

Number of studies identified

The search retrieved 7858 unique citations relating to clinical effectiveness (4223 duplicates were removed). 7600 articles were excluded at title/abstract stage, and 243 articles were examined at full-text level, 15 articles were unobtainable (see Appendix 7). In addition, 1032 articles were examined from ongoing trials registers and conference proceedings.

Number and type of studies included

Four randomised controlled trials were included: M39021 trial by Marcus *et al.*^{94,95}, GLSG-2000 by Hiddemann *et al.*^{90,91}, OSHO-39 trial by Herold *et al.*⁹² and the FL2000 trial by Salles *et al.*⁹³. Overall 24 published reports were identified which related to the four included studies, and these are listed in Appendix 8. The principle source/sources for each study are listed in Table 6:

Table 6: Primary reports for each trial

Trial	Primary Report(s)
M39021	Marcus <i>et al.</i> 2008 ⁹⁴ ; Marcus <i>et al.</i> 2005 ⁹⁵
GLSG-2000	Hiddemann <i>et al.</i> 2005 ⁹¹ ; Buske <i>et al.</i> 2008 ⁹⁰
OSHO-39	Herold <i>et al.</i> 2007 ⁹²
FL2000	Salles <i>et al.</i> 2008 ⁹³

Number and type of studies excluded

In total 212 citations were excluded from the full text selection (see Appendix 9). Studies that could potentially have provided head-to-head data for the interventions and comparators accounted for 108 excluded articles; 44 were excluded because they were not RCTs i.e. case reports, literature reviews, commentaries and single arm interventions; 29 studies were excluded because the interventions used were not relevant; 13 studies were excluded because the patient group was clinically heterogeneous and data for patients with FL was not reported separately; nine studies were excluded because patients did not have FL (e.g. Hodgkin's disease or non-Hodgkin's lymphoma unspecified) or had aggressive disease; six studies did not provide first-line treatment; five non-English language studies were excluded; two were study protocols and one did not provide relevant outcome data.

One hundred and four citations which were potential candidates to inform a network meta-analysis were excluded. Fifty four were excluded because the participants did not have FL (e.g. NHL not specified) or the disease was not indolent; 21 were excluded because the population was heterogeneous and data relating to FL were not reported separately; 15 were excluded because the

interventions were not relevant; eight were excluded because they were not randomised controlled trials; four were excluded because they were non-English language reports; one was excluded as outcome data were not relevant, and one study was not included as it did not report on first-line treatment.

Studies identified for a potential network meta-analysis

Three additional studies (corresponding to seven references, see Appendix 10 for list) met the criteria for providing evidence within a network meta-analysis; that is the population included FL (with analysis for FL presented separately), the therapy being investigated was either a relevant intervention or comparator (as stated in the decision problem-, section 4) and appropriate outcomes were reported (as stated in the decision problem, section 4) (see Figure 3).

Incorporating these three studies into a network of evidence would facilitate the comparison of interventions where a direct head-to-head trial was not available (as depicted in Figure 3). However, the network meta-analysis was not undertaken as it was not deemed appropriate given that treatment efficacy is not the only factor in terms of choice of chemotherapy selection (see background section for discussion of other factors). Additionally, head-to-head data were available to inform a comparison between a chemotherapy regimen and that regimen with the addition of rituximab. It is noted that NICE has a strong preference for evidence from head-to-head RCTs that directly compare the technology with the appropriate comparator in the relevant patient groups as stated in the NICE methods guide (p.15).⁹⁶

Figure 3: Network of evidence

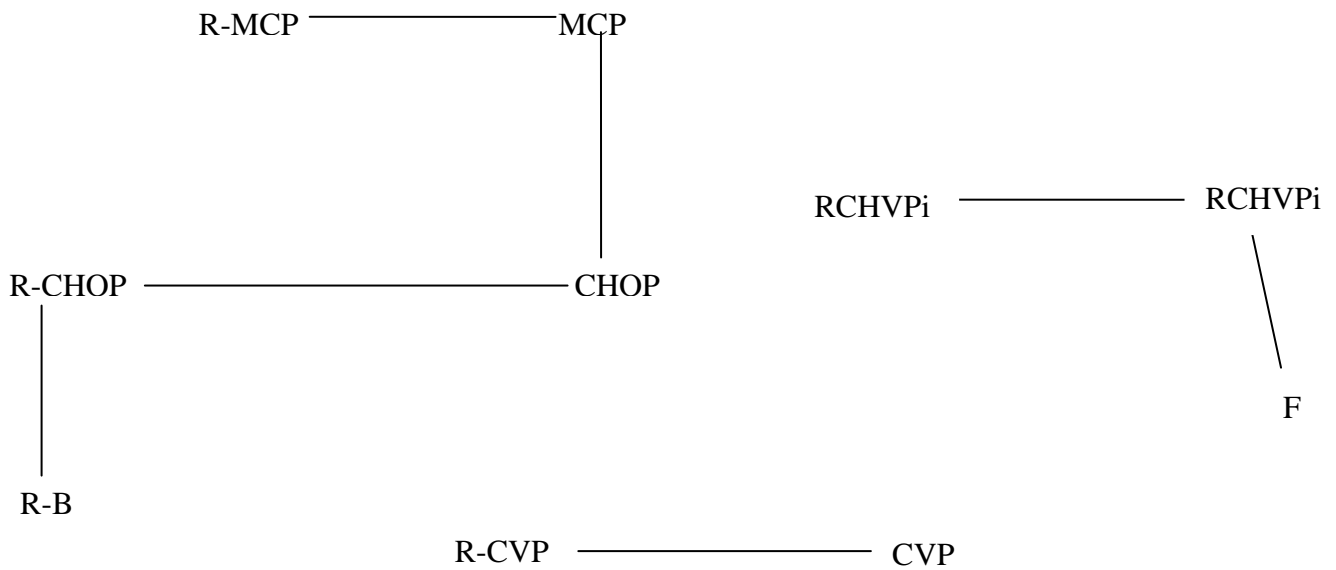

————— = head to head comparison, each line represents a single study

Ongoing trials

Seven ongoing studies were identified (Table 7). Four studies are investigating one R-chemotherapy against another R-chemotherapy; one study is closed (STiL) with study follow-up complete and initial results reported as a conference abstract;⁷⁵ one study is ongoing but not recruiting (ML17638)⁹⁷ and two studies are ongoing and still recruiting (PACIFICO and PLRG4).^{78,77} The study population in the PACIFICO trial⁷⁸ is patients with FL aged > 60 years or aged < 60 years but with an anthracycline-based therapy contra-indicated. Two ongoing studies are investigating the use of rituximab in maintenance following first-line induction therapy; one study is closed with follow-up completed (PRIMA trial)⁶⁹ whilst the other study (ML17638)⁹⁷ is ongoing but not recruiting. One study is investigating one chemotherapy versus another chemotherapy regimen (BNLI MCD vs. FMD).⁹⁸

Table 7: Ongoing trials in FL that meet the inclusion/exclusion criteria

Study	PRIMA study ⁶⁹	STiL trial (Rummel 2009) ⁷⁵	BNLI MCD vs. FMD ⁹⁸	R-CVP vs. R-CHOP vs. R-FM ⁷⁶	ML17638 ⁹⁷	PACIFICO ⁷⁸	PLRG4 (Polish Lymphoma Research Group) ⁷⁷
Study identifier	UKCRN ID 2249	Clinical trials. gov ID NCT00991211	UKCRN ID 908	Clinical trials.gov ID NCT00774826	Clinical trials. gov ID NCT01144364	UKCRN ID 6898	Clinical trials. gov ID NCT00801281
Participants	FL N= 1200 Age: > 18 years	FL and mantle cell lymphoma N= 549 Age: 18 and over	FL N= 400 Age: 18-70	FL (inc. Stage II) N= 431 Age: 18-75	FL Target sample size is 100-500 Age: 60-75	FL N= 680 Age: ≥60 years, or <60 years but anthracycline-based therapy contra-indicated.	FL N= 250 Age: ≥ 18 years
Treatment	After induction of response with Rituximab and chemotherapy: 1. Maintenance therapy with Rituximab 2. No maintenance therapy	1. Rituximab + bendamustine 2. R-CHOP	1. MCD 2. FMD	1. R-CVP 2. R-CHOP 3. R-FM	After brief induction with chemotherapy (FMD) plus rituximab: 1. Rituximab maintenance 2. No further therapy	1. R-CVP 2. R-FC	1. R-CVP 2. R-CHOP
Status	Closed - follow-up complete	Closed- follow-up complete	Closed – follow-up complete	Ongoing treatment phase, not recruiting.	Ongoing treatment phase, not recruiting	Ongoing treatment phase, recruiting.	Ongoing treatment phase, recruiting.

CHOP= Cyclophosphamide, Doxorubicin, Vincristine, Prednisone ; CVP= cyclophosphamide, vincristine and prednisone; FMD= Fludarabine, Mitoxantrone, Dexamethasone
FC= fludarabine and cyclophosphamide; FL= follicular lymphoma; MCD= mitoxantrone, chlorambucil and dexamethasone.

5.2.2 Summary of trials

Four multicentre, open-label trials were included which randomised between 322 and 630 participants. The GLSG-2000^{90,91} and OSHO-39 trials⁹² were undertaken in Germany; the M39021 trial^{94,95,94} was undertaken in centres across eleven countries including the UK and FL2000 trial⁹³ was undertaken in centres within France and Belgium. Three trials compared a rituximab-chemotherapy regimen with a chemotherapy alone regimen; the FL2000 trial compared a rituximab-chemotherapy-biological regimen with a chemotherapy-biological regimen alone. The median follow-up ranged from 47 to 60 months (Table 8).

Table 8: Summary of included studies

Trial	Study type Country	Numbers randomised	Intervention	Comparator	Follow-up
M39021 ^{94,95}	Multicentre, open label RCT 47 centres in Australia, Belgium, Brazil, Canada, France, Israel, Poland, Portugal, Spain, Switzerland, and the UK.	N=322 ^a Stage III-IV FL	R-CVP N=162	CVP N= 159	Median 53 months (no range reported)
GLSG- 2000 ^{90,91}	Multicentre, open label RCT 200 institutions in Germany	N=630 ^b Stage III-IV FL	R-CHOP N=279	CHOP N=278	Median 56 months (no range reported)
OSHO-39 ⁹²	Multicentre, open label RCT 34 centres in Germany	N=376 [including MCL] N=201/376 were FL Stage III-IV FL	R-MCP N=105	MCP N=96	Median 47 months (49 months for R=MCP and 42 months for MCP) (no range reported)
FL2000 ⁹³	Multi-centre, open label RCT 54 centres in France and Belgium	N=360 ^c Stage II-IV	R-CHVPi N=175	CHVPi N=183	Median 60 months (range 0.2-6.4 years)

^a One CVP enrolled patient withdrew consent ^b N=630 enrolled. In June 2003, applied one-sided sequential test showed a significantly longer TTF for the R-CHOP arm (p=0.001) and randomisation was stopped. Buske et al⁹⁰ report on 557/630 evaluable patients at a median follow-up of 56 months. ^c 1 patient withdrew consent after registration, 1 patient had a major inclusion violation (which was registered at relapse) **Abbreviations:** CHOP= cyclophosphamide, doxorubicin, vincristine, prednisolone; CHVPi= cyclophosphamide, doxorubicin, vindesine, prednisolone and interferon-alpha; CVP= cyclophosphamide, doxorubicin, vincristine, prednisolone; FL=follicular lymphoma; MCL= mantle cell lymphoma; MCP= mitoxantrone, chlorambucil, prednisolone; R=rituximab

Population

Baseline demographic data is provided in Table 9. The target population were advanced stage FL patients who were symptomatic and requiring treatment (detailed eligibility criteria for each study are presented in the data extraction tables in Appendix 11). The M39021^{94,95} and GLSG-2000 trials^{90,91} recruited patients of stage III-IV FL; the FL2000 trial⁹³ recruited stage II-IV FL. The OSHO-39 trial⁹² included CD20-positive indolent NHL which included lymphoplasmacytic lymphoma or mantle cell lymphoma (MCL); however the primary analysis population was defined as the population of patients with FL. The OSHO-39⁹² and GLSG-2000⁹¹ limited to Grade 1 or 2 FL (WHO classification); the M39021 trial^{94,95} included Grade 1-3 FL and the FL200 trial⁹³ included Grades 1, 2 and 3a FL.

The median age of patients randomised across the trials ranged from 52 to 61 years. Two trials presented the percentage of participants aged over 60 years: 26% in the M39021 trial^{94,95} and 52% in FL2000 trial⁹³. The majority of patients had Stage IV FL (69% to 77% in the three studies which reported this data). Most participants had an ECOG performance status of 0 to 1, ranging from 91-97%. Bone marrow involvement was present in 62% to 74% of patients, and 22% to 44% presented with one or more B symptom (defined as fever, weight loss or night sweating). Elevated LDH levels (a marker of aggressive disease) were recorded in 26% to 37% of patients.

Within the individual studies, the treatment groups were well balanced with respect to demographic and disease characteristics; with the exception of gender in OSHO-39 trial⁹² (greater number of males in the R-MCP group, no p value reported) and the GLSG-2000 trial (higher proportion of males in the CHOP arm, p=0.027). The populations were reasonably similar when compared across the four studies, although there were some differences: including younger median age (52-3 years) in the M39021 trial,^{94,95} larger proportion of patients aged >60 years old and inclusion of stage II participants in the FL2000 trial.⁹³ The study populations included were generally reflective of the general FL population, with the exception of age; the median age of participants in the trials being younger than seen in clinical practice (70% are aged over 60 years when diagnosed).¹⁰ The younger median age of trial participants meant ECOG performance status was better than seen in clinical practice. In addition the M39021^{95,94} and OSHO-39⁹² trials excluded patients with an ECOG performance status of >2.

Table 9: Baseline demographic data for the four included studies^a

	M39021 ^{94,95}		GLSG-2000 ^{90,91}		OSHO-39 ⁹²		FL2000 ⁹³	
	R-CVP N=162	CVP N=159	R-CHOP N=279	CHOP N=278	R-MCP N=105	MCP N=96	R-CHVPi N=175	CHVPi N=183
Age and Gender								
Median age in years (range)	52	53	57 (27-90)	57 (21-81)	60 (33-78)	57 (31-75)	61 (25-75)	
Aged >60 years	41 (25%)	44 (28%)	NR	NR	NR	NR	89 (51%)	96 (52%)
Male	88 (54%)	85 (53%)	120 (43%)	146 (53%)	53 (50%)	36 (37%)	96 (55%)	82 (45%)
Female	74 (46%)	74 (47%)	159 (57%)	132 (47%)	52 (50%)	60 (63%)	79 (45%)	101 (55%)
Ann Arbor Stage								
II	2 (1%)	2 (1%)	0	0	0	0	23 (13%)	18 (10%)
III	45 (28%)	45 (28%)	NR	NR	30 (29%)	22 (23%)	152 (87%)	165 (90%)
IV	114 (70%)	112 (70%)	194 (70%)	191 (69%)	75 (71%)	74 (77%)		
Not evaluable/missing	1 (1%)	0 (0%)	NR	NR	0 (0%)	0 (0%)	0 (0%)	0 (0%)
Performance status (ECOG)								
0	93 (57%)	90 (57%)	97 (35%)	88 (32%)	68 (65%)	54 (56%)	164 (94%)	167 (91%)
1	65 (40%)	60 (38%)	155 (56%)	167 (60%)	29 (28%)	36 (38%)		
>1	4 (2%)	8 (5%)	18 (6%)	19 (7%)	7 (7%)	6 (6%)	11 (6%)	16 (9%)
Not evaluable/missing	0 (0%)	1 (0.6%)	9 (3%)	4 (1%)	1 (1%)	0 (0%)	0 (0%)	0 (0%)
IPI								
0	1 (1%)	1 (1%)	NR	NR	NR	NR	NR	NR
1	72 (44%)	69 (43%)					NR	NR
2	57 (35%)	57 (36%)					NR	NR
3	19 (12%)	21 (13%)	NR	NR	NR	NR	60 (34%)	71 (39%)
4	2 (1%)	3 (2%)					NR	NR

	M39021^{94,95}		GLSG-2000^{90,91}		OSHO-39⁹²		FL2000⁹³	
	R-CVP N=162	CVP N=159	R-CHOP N=279	CHOP N=278	R-MCP N=105	MCP N=96	R-CHVPi N=175	CHVPi N=183
Not evaluable/missing	11 (7%)	8 (5%)					NR	NR
FLIPI								
Low (0 to 1)	80 (49%)	75 (47%)	39 (14%)	31 (11%)	8 (8%)	6 (6%)	28 (16%)	37 (20%)
Intermediate (2)			114 (41%)	119 (43%)	38 (36%)	37 (39%)	63 (36%)	59 (32%)
High (3-5)	71 (44%)	75 (47%)	123 (44%)	123 (44%)	59 (56%)	53 (55%)	79 (45%)	83 (45%)
Not evaluable/missing	11 (7%)	9 (6%)	3 (1%)	5 (2%)	0 (0%)	0 (0%)	5 (3%)	4 (2%)
Other factors								
B-symptoms presence	65 (40%)	51 (32%)	108 (39%)	113 (41%)	≥ 46 (44%)	≥ 34 (35%)	38 (22%)	52 (28%)
Bone marrow involvement	103 (64%)	102 (64%)	180 (65%)	179 (64%)	73 (70%)	71 (74%)	108 (62%)	121 (66%)
>1 extranodal sites	28 (17%)	27 (17%)	NR	NR	NR	NR	60 (34%)	73 (40%)
Elevated LDH ^b	39 (26%)	39 (26%)	73 (26%)	66 (24%)	31 (30%)	30 (31%)	64 (37%)	66 (36%)
β2-microglobulin >3mg/L ^c	146 (99%)	141 (100%)	NR	NR	NR	NR	62 (35%)	56 (31%)
Haemoglobin <12 g/dl	NR	NR	54 (19%)	56 (20%)	NR	NR	37 (21%)	30 (16%)

^a Percentages may not add up to 100% due to rounding. ^b Percentages not based on the 162 and 159 patients R-CVP group and CVP respectively due to missing patient values (seven patients in the CVP group and 10 patients in the R-CVP group). ^c Percentages not based on the 162 and 159 patients R-CVP group and CVP respectively due to missing patient values (eighteen patients in the CVP group and 15 patients in the R-CVP group) Abbreviations: ECOG: Eastern Cooperative Oncology Group; FLIPI=Follicular lymphoma International Prognostic Index; IPI=International Prognostic Index; LDH= lactate dehydrogenase; NR= not reported

Interventions and comparators

The interventions in each of the four studies were a rituximab and chemotherapy combination; each trial used a different chemotherapy agent. The comparator within each trial was the chemotherapy regimen minus rituximab. These are described in Table 10. Two studies provided subsequent treatment following response to first-line treatment. The OSHO-39 trial⁹² planned to provide all responders with interferon-alpha maintenance (3 x million international units (MIU)/week) until disease progression. The GLSG-2000 trial^{90,91} randomised responding patients who were aged less than 60 years old to a high dose chemotherapy regimen followed by autologous stem cell transplant or interferon-alpha maintenance treatment (3 x 5 MIU/week until disease progression or intolerable adverse events). Patients aged ≥ 60 years old received interferon-alpha maintenance.

Table 10: Treatment regimens

Author/study	Treatment regimens	Cycles	Response assessment	Amendment to dose or cycles
M39021 ^{94,95}	CVP: 750 mg/m ² cyclophosphamide intravenously on day 1; 1.4 mg/m ² of vincristine, up to a maximal dose of 2 mg i.v. on day 1; and 40 mg/m ² of prednisone per day p.o. on days 1 to 5. Rituximab: 375 mg/m ² infusion on day 1	Every 21 days for a maximum of 8 cycles.	Assessed after cycle 4 and at the end of treatment	Insufficient therapeutic response i.e. PD or SD after cycle 4 were withdrawn from study treatment. Those achieving at least a PR continued to 8 cycles.
GLSG-2000 ^{90,91}	CHOP: 750 mg/m ² cyclophosphamide; 50 mg/m ² doxorubicin, 1.4 mg/m ² vincristine: all given i.v. on day 1. Prednisolone given 100mg/m ² daily on days 1 to 5 p.o. Rituximab: 375 mg/m ² infusion on the day before the respective CHOP course.	Every 21 days for a total of 6 to 8 cycles	Assessed every 2 cycles and 4 weeks after completion of last course	Patients, in either study arm, with PD at any time during the study were taken off the study Patients achieving CR after 4 cycles were treated with a total of 6 cycles; all other patients received 8 cycles.
OSHO-39 ⁹²	MCP: 8mg/m ² mitoxantrone i.v. on days 1 and 2; 3 x 3mg/m ² chlorambucil and 25mg/m ² prednisolone p.o. on days 1 to 5. Rituximab: 375 mg/m ² i.v. infusion on day 1 (8mg/m ² mitoxantrone i.v. on days 3 and 4; 3 x 3mg/m ² chlorambucil and 25mg/m ² prednisolone p.o. on days 3 to 7).	Every 28 days for a maximum of 8 cycles.	After completion of induction treatment, patients were observed every 8 weeks during the first year, at 3-month intervals during the second year, and then every 6 months from the third year onward.	Patients with PD after 2 cycles of therapy or who had not reached a PR or CR after 6 cycles of therapy were prematurely withdrawn from study CR or a PR after 6 cycles treatment received a further 2 cycles of treatment.

Author/study	Treatment regimens	Cycles	Response assessment	Amendment to dose or cycles
FL2000 ⁹³	<p>CHVPi: 600 mg/m² cyclophosphamide i.v. on day 1 and 25 mg/m² i.v. doxorubicin on day 1 and 100 mg/m² etoposide, all administered IV on day 1; 40 mg/m² prednisolone p.o. from day 1 to day 5</p> <p>Ifn-α s.c. 3 x 4.5* MIU/week</p> <p>*3 MU for patients older than 70 years.</p> <p>Rituximab: 375 mg/m² infusion on days 1 and 8 of cycle 3 and 4, and day 1 of cycles 5 and 6. (Thus, CHVP only in cycles 1 and 2)</p>	<p>CHVPi: 6 monthly cycles followed by 6 bi-monthly cycles) and 18 months Ifn-α</p> <p>R-CHVPi: 6 monthly cycles</p> <p>CHVP or R-CHVP (see column to left) and 18 months concurrent Ifn-α</p>	<p>Evaluation of response performed after 6 chemotherapy courses (6 months) and at the end of the whole treatment (18 months).</p>	<p>No dose reduction of chemotherapy was planned or allowed (but could be delayed for 7 days if the absolute neutrophil count was <1.5g/L of the platelet count was <100g/L)</p>

Abbreviations: CR= complete response PR= partial response; i.v.= intravenously, p.o.= orally; PD= disease progression; SD=stable disease; MIU= million international units; Ifn- α = interferon-alpha

Outcomes

The clinical efficacy outcomes reported in the four studies are shown in Table 11; primary outcomes are highlighted in grey. All four studies included the appropriate outcome measure of overall survival (OS); defined as the time from randomisation to the date of death by any cause. The OSHO-39 trial⁹² was the only trial to report progression-free survival (PFS), defined as randomisation to disease progression or death from NHL. All four studies appropriately reported response rates (according to the International Workshop criteria described by Cheson et al.⁸⁷ Two studies did not use the category of “unconfirmed complete responders” (CRu), instead counting such patients within the Partial Responder (PR) category.^{92,90,91} The FL2000 trial⁹³ and M39021 trial^{95,94} used the category of CRus and presented the numbers separately from complete responders (CR) and PR. No studies reported the duration of disease remission, although the studies did report a number of time to event outcomes which approximated disease remission, for example all four studies reported response duration as an outcome.

Other time to event outcomes reported by one or more of the studies were event free survival (EFS), time to treatment failure (TTF), time to next antilymphoma treatment (TTNT), disease free survival (DFS) and time to progression (TTP). However, these outcomes were inconsistently defined by the four studies and thus not directly comparable across the four studies. For example, the M39021^{94,95} and GLSG-2000 trials^{90,91} measured TTF and both studies considered a treatment failure as disease progression. However, the M39021 trial^{94,95} also additionally considered death by any cause, relapse after response, new antilymphoma treatment or stable disease after cycle 4 as treatment failures; whilst the GLSG-2000 trial^{90,91} also considered resistance to initial therapy and death not specified as treatment failures. In addition, when the definitions for each time to event outcome were cross-referenced against each other, no outcomes were directly comparable (for e.g. we examined whether PFS as measured in the OSHO-39 trial⁹² may have matched the definition used for EFS as measured by FL2000 trial⁹³, however this was not the case). Appendix 12 provides the definitions for each outcome described in the four studies.

Table 11: Clinical efficacy outcomes reported in four studies

Study	PFS	OS	ORR	CR	PR	RD	EFS	TTF	TTNT	DFS	TTP
M39021 ^{94,95}		✓	✓	✓	✓	✓		✓	✓	✓	✓
GLSG-2000 ^{90,91}		✓	✓	✓	✓	✓		✓	✓		
OSHO-39 ⁹²	✓	✓	✓	✓	✓	✓	✓		✓		
FL2000 ⁹³		✓	✓	✓	✓	✓	✓				

Nb: Cells in grey represent the primary outcome of the trial. Abbreviations: CR=complete response; DFS=disease-free survival; EFS=event free survival; ORR=overall response rate; OS= overall survival; PFS=progression-free survival; PR=partial response; RD=response duration; TTNT=time to next antilymphoma treatment; TTP=time to progression; TTF=time to treatment failure.

All four studies reported data on adverse events. The M39021, OSHO-39 and FL2000 trials^{92,93,94,95} graded adverse events in accordance with the National Cancer Institute Common Toxicity Criteria (NCI-CTC) grading system;⁹⁹ the GLSG-2000 trial^{90,91} used the WHO toxicity criteria¹⁰⁰ to record adverse events. The GLSG-2000 and OSHO-39 trials⁹² reported data for grade 1, 2, 3 and 4 adverse events separately^{91,92} and the M39021 and FL2000 trials^{95,94,93} reported adverse events for grades 3 and 4 combined.^{95,94,93} None of the studies reported health-related quality of life as an outcome.

Quality assessment

All four included studies were randomised and allocation was concealed using centralised allocation to treatment. Numbers randomised were stated in all four studies. None of the studies were blinded; all were open label and none of the studies reported attempting to conceal treatment allocation from the outcome assessors. Power calculations were undertaken by all four included studies. At least 80% of patients were followed up in all four studies. All four studies reported baseline characteristics and were mostly balanced between treatment groups; with the exception of gender in OSHO-39 trial⁹² (greater number of males in the R-MCP group, no p value reported) and the GLSG-2000 trial (higher proportion of males in the CHOP arm, $p=0.027$). The M39021^{94,95} and FL-2000 trials⁹³ reported no significant differences in baseline data. All studies specified eligibility criteria.

Co-interventions were used in three studies. Interferon maintenance therapy was given to patients in the OSHO-39 trial⁹² achieving a partial or complete remission; this was initiated within 4 to 8 weeks after treatment completion. In the GLSG-2000 trial^{90,91}, patients < 60 years who had achieved either complete or partial response were offered a second randomisation of DexaBEAM regime (salvage chemotherapy) followed by stem cell harvest and radiochemotherapy, or long term interferon maintenance; whereas patients > 60 years were given interferon maintenance. Patients in both arms in the FL2000 trial⁹³ were given interferon- α as part of initial treatment (6 months) and then as a consolidation treatment for a further 12 months. In addition, 11% of patients in the FL2000 trial⁹³ had stage II FL. Reasons for withdrawals were unclear in the four studies. Most withdrawals were stated as due to disease progression; however withdrawals relating to adverse events were not explicitly stated. All four studies reported using intention to treat analyses. See Figure 4 for overview of the quality assessment.

Figure 4: Quality assessment of the included trials (+=Yes; -=No; ?=Unclear)



5.2.3 Assessment of effectiveness

Response to treatment

Response to treatment is reported in Table 12. Overall response rate (ORR) was significantly improved for patients receiving rituximab with chemotherapy compared with those who received chemotherapy alone in three studies (the FL2000 trial⁹³ did not report a p value). The ORR in the four studies ranged from 81% to 97% for the R-chemotherapy arm and 57% and 91% for the chemotherapy only arm. The difference in ORR between the treatment and comparator arms in each of the four studies ranged between 5% and 24%; the greatest difference was between the R-CVP and CVP arm. R-CHOP, R-CHVPi and R-MCP were the regimens that provided the highest ORR of 96%, 94% and 92% respectively. CHOP alone provided a high ORR of 91%.

Difference in the complete response (CR) rates between treatment and comparator arms in the four studies ranged from 2- 25%, and was reported as significant in two studies. The regimens providing the highest CR rates were R-CHVPi and R-MCP (51% and 50% respectively). The number of CRs in the GLSG-2000 trial^{90,91} for both R-CHOP and CHOP (19% and 17% respectively) were notably lower than those reported in the other studies. The greatest difference in CR between treatment and comparator arms was reported in the OSHO-39 trial⁹² between R-MCP and MCP (25%).

The difference in partial response (PR) rate ranged from 2% to 11%. None of the four studies reported a p value for the difference between treatment and comparator arms.

The GLSG-2000^{90,91} and FL2000 trials⁹³ reported low numbers of patients within the stable disease (SD) category. However the M39021 trial^{94,95} reported greater numbers of SD patients (7% in R-CVP and 21% in CVP). Meta-analysis of response rates in the four trials has been explored (see Section 5.2.5 for further discussion).

Chi-square test for response rates

The AG performed a Chi square test on the response rate data to compare the numbers within each category of response between the two trial arms for each of the four trials. The results showed that there was a statistically significant difference in the numbers in the response categories for the R-chemotherapy arm compared with the chemotherapy alone arm for R-CVP vs. CVP, R-MCP vs. MCP and R-CHVPi vs. CHVPi six month response rate ($p < 0.001$ for all comparisons). The difference between the categories of response was not statistically significant for R-CHOP versus CHOP ($p = 0.15$) and for the R-CHVPi vs. CHVPi 18 month response rate ($p = 0.12$).

A second analysis was performed for each trial which combined relevant categories of response (e.g. progressive disease or death) where necessary so that the number of observations within each category was greater than five per cell. Where grouping was performed death was categorised with progressive disease. In one analysis, stable disease was categorised with PD and death, as clinical advice to the AG indicates that patients with stable disease are treated as PD patients and not responders. In terms of statistical significance at the 5% level, the effects of grouping only altered on comparison, that of R-CHVPi and CHVPi at 18 months which became statistically significant. Analyses are presented in full in Appendix 13.

Table 12: Response to treatment in the four included studies^a

	M39021^{94,95}		GLSG-2000^{90,91}		OSHO-39⁹²		FL2000⁹³			
	53 months		56 months		47 months		6 month follow-up data		18 month follow-up data	
Median follow-up	53 months		56 months		47 months		60 months		60 months	
	R-CVP N=162	CVP N=159	R-CHOP N= 279	CHOP N= 278	R-MCP N=105	MCP N=96	R-CHVPi N= 175	CHVPi N=183	R-CHVPi N= 175	CHVPi N=183
OR: Number (%)	131 (81) 95% CI (74% to 87%)	90 (57) 95% CI (49% to 64%)	268 (96) No CI reported	253 (91) No CI reported	97 (92) No CI reported	72 (75) No CI reported	164 (94) No CI reported	156 (85) No CI reported	142 (81) No CI reported	131 (72) No CI reported
p value reported in study	<0.0001		0.0046		0.0009		Not reported		Not reported	
Relative risk^b	1.43 (1.22, 1.67)		1.06 (1.01, 1.10)		1.23 (1.08, 1.40)		1.10 (1.02, 1.18)		1.13 (1.01, 1.27)	
CR: Number (%)	49 (30%)	12 (8%)	53 (19)	47 (17)	52 (50)	24 (25)	63 (36)	29 (16)	90 (51)	71 (39)
p value reported in study	<0.001		No p value reported		0.0004		Not reported ^e		Not reported ^f	
Relative risk^b	4.01 (2.22-7.25)		1.12 (0.79, 1.60)		1.98 (1.33, 2.95)		2.27 (1.54-3.35)		1.33 (1.05, 1.67)	
PR: Number (%)	82 (51)	78 (49)	215 (77)	206 (74)	45(43)	48 (50)	101 (58)	127 (69)	52 (30)	60 (33)
	No p value reported		No p value reported		No p value reported		Not reported ^e		Not reported ^f	
Relative risk^b	1.03 (0.83, 1.29)		1.04 (0.95, 1.14)		0.86 (0.64, 1.15)		0.83 (0.71-0.98)		0.91 (0.67, 1.23)	
Stable disease: N (%)	12 (7)	33 (21)	6 (2) ^c	17 (6) ^c	Not reported ^d	Not reported ^d	2 (1)	9 (5)	1 (1)	3 (2)

	M39021 ^{94,95}		GLSG-2000 ^{90,91}		OSHO-39 ⁹²		FL2000 ⁹³			
	53 months		56 months		47 months		6 month follow-up data		18 month follow-up data	
Median follow-up	53 months		56 months		47 months		60 months		60 months	
	R-CVP N=162	CVP N=159	R-CHOP N= 279	CHOP N= 278	R-MCP N=105	MCP N=96	R-CHVPi N= 175	CHVPi N=183	R-CHVPi N= 175	CHVPi N=183
p value reported in study	No p value reported		No p value reported		No p value reported		Not reported ^e		Not reported ^f	
Progressive disease: N (%)	17 (10)	31 (19)	3 (1)	6 (2)	3 (3) [After 2 cycles]	10 (10) [After 2 cycles]	8 (5)	18 (10)	31 (18)	47 (26)
p value reported in study	No p value reported		No p value reported		No p value reported		Not reported ^e		Not reported ^f	

^aPercentages may not add up due to rounding ^b Relative risk of being a responder to R-chemotherapy compared to chemotherapy alone calculated in RevMan; ^c Includes ‘minor response’ as well as stable disease; ^d Stable disease not reported but “< partial response” reported at cycle 6: R-MCP= 7 & MCP=22 and at cycle 8: R-MCP= 8 & MCP=24; ^e Authors report p<0.001 obtained using a global χ^2 test for all response strata [does not include ORR]; ^f Authors report p=0.035 obtained using a global χ^2 test for all response strata [does not include ORR]. Abbreviations: CI= confidence interval; CR= complete response; CRu= unconfirmed complete response; OR=Overall response ; PR=partial response; NR=not reported

Overall survival

The overall survival (OS) rate in the four studies ranged from 83% to 90% in the R-chemotherapy arms and 77% to 84% in the chemotherapy alone arms. The difference in OS rate was significantly improved in three trials when R-chemotherapy was compared to chemotherapy alone; the exception being the FL2000 trial⁹³ (p=0.1552). The median OS was reported as not reached in three studies and was not reported in the FL2000 trial.⁹³ The OS data from the GLSG-2000^{90,91} and OSHO-39⁹² trials were confounded due to the effects of subsequent therapy provided to all responders to first-line treatment. The FL2000 trial⁹³ also provided additional treatment (interferon- α) to both treatment arms during the six-month remission induction phase. In addition, the FL2000 trial⁹³ provided a further 12-month treatment phase where the chemotherapy alone arm received bimonthly CHVP and both treatment arms received interferon- α .

Table 13: Overall survival in the four included studies

	M39021 ⁹⁴		GLSG-2000 ^{90,91}		OSHO-39 ⁹²		FL2000 ⁹³	
	R-CVP N=162	CVP N=159	R-CHOP N=279	CHOP N= 278	R-MCP N=105	MCP N=96	R- CHVPi N= 175	CHVPi N=183
Median Follow-up	53 months		56 months		47 months		60 months	
OS rate %	83 95% CI (77 to 89) ^a	77 95% CI (70 to 83) ^a	90 (CI NR) ^c	84 (CI NR) ^c	87 (CI NR) ^c	74 (CI NR) ^c	84 95% CI (78-84) ^g	79 95% CI, 72-84) ^g
p value reported in trial	<0.0290		0.0493		0.0096		0.1552	
Median OS	Not reached	Not reached	Not reached	Not reached	Not reached	Not reached	Not reported	Not reported
Number of deaths	23 ^b	35 ^b	6 ^d	17 ^d	15 ^f	25 ^f	Not reported	Not reported
p value reported in trial	No p value reported		0.016		No p value reported		No p value reported	
Hazard ratios ^h	0.64		0.58		0.40		1.46	

^aKM estimate at 4 years ^b Deaths reported from Solal-Celigny,¹⁰¹ may include patients who have received second-line treatment : median 42 month follow-up; number deaths at 4 year follow-up⁹⁴ not reported ^c5-year rate ^dDeaths after 3 years reported⁹¹(not reported for 5 years)⁹⁰ ^e4-year OS rates ^fDeaths at 4 years; cause-specific deaths in FL were n=7 R-MCP and n=17 in MCP⁹² ^g 5-year rate; Abbreviations: CI= confidence interval; ^h Calculated by the AG using the method described below.

OS: Hazard ratios

The hazard ratios for OS were not available in the manuscripts for each of the individual trials. The AG used Kaplan Meier (KM) plot data provided in the health economic model in the MS,⁶¹ which provided a series of survival probability estimates at monthly timepoints for two of the four trials: M39021 and OSHO-39 trials.^{95,94,92} Visual inspection of these probability estimates alongside the KM provided in the publications for each trial indicated that these data were reasonable. KM data for OS for the FL2000 trial⁹³ and the most-up-to-date data for the GLSG-2000 trial⁹⁰ were digitised by the AG using TechDig[®] software to estimate survival probability estimates at timepoints along the KM curve.

The respective hazard ratios were calculated by taking the ratio of the cumulative hazard from the R-chemotherapy and chemotherapy arms from the OS KM curves. The cumulative hazard was calculated by summing the negative log of the survival probabilities ($H(t) = -S \log[S(t)]$) for each treatment arm, restricted to the clinical follow-up reported in the respective publications.¹⁰² There are limitations with this method of calculating hazard ratios, namely that it relies on the data from the respective trial publications rather than patient-level data and that estimating survival probabilities from digitised curves are subject to inaccuracies. As such these estimates provide an indication of the hazard ratio for OS rather than definitive values. Given resource constraints and data limitations, it was not possible to calculate the standard errors and confidence intervals to give an indication of the uncertainty in the data.

For the M39021, GLSG-2000 and OSHO-39 trials,^{91,90,92,103,95} there was an increased likelihood of survival if receiving R-chemotherapy. For R-CVP vs. CVP, there was 36% increased survival benefit, for R-CHOP vs. CHOP there was a 42% increased survival benefit, and for R-MCP vs. MCP a 60% increased survival benefit. However, it is noted that the treatment effect on OS is confounded in the latter two trials due to additional trial treatments administered after response to first-line treatment. The FL2000 trial⁹³ provided contradictory evidence with there being a 46% increased likelihood of survival in the CHVPi alone arm compared with the R-CHVPi arm. One explanation for this might be the differences in treatments received in the intervention and comparator arms during the last 12 months of treatment. Whilst both arms received interferon during this period, the comparator arm also received bimonthly CHVP.

Progression free survival

The median progression free survival (PFS) was significantly prolonged in OSHO-39 trial⁹² for the R-chemotherapy arm (R-MCP) (28.8 months MCP versus median not reached R-MCP, $p < 0.0001$). PFS was not reported in the other three trials.

Other time to event data

Several other efficacy outcomes, namely time to event data, were reported in the four studies. As stated in section 5.2.2, these outcomes were inconsistently defined between the four studies and thus not directly comparable (see Appendix 12). In addition, the time to event data were confounded in GLSG-2000^{90,91} and OSO-39⁹² trials due to the effects of subsequent treatment provided to responders to first-line treatment in these trials. However, we present a summary of the findings in Table 14.

The median response duration was significantly prolonged for the rituximab with chemotherapy arm compared with the chemotherapy alone arms ($p < 0.001$) in the M39021 and OSO-39 trials.^{92,94,95} Two studies reported the duration of response which differed significantly between treatment and comparator arms; at 5 years in the GLSG-2000 trial^{90,91} ($p < 0.0001$) and the 4 year estimates presented in the FL2000 trial⁹³ ($p = 0.012$). Significantly prolonged ($p < 0.0001$) median time to treatment failure (TTF) was reported for the R-chemotherapy arm compared with chemotherapy alone arm in the M39021 and GLSG-2000 trials.^{90,91,94,95} Similarly, median event free survival (EFS) was significantly improved in the R-chemotherapy arms in two studies compared with the chemo alone arms (median EFS MCP 26 months, not reached in R-MCP, $p < 0.0001$; median EFS 35 months in CHVPi, not reached in R-CHVPi, $p = 0.0004$).^{92,93} The M39021, GLSG-2000 and OSO-39 trials reported a statistically significant difference in time to next anti-lymphoma treatment (TTNT).^{92,91,90,95,94} The M39021 trial^{94,95} reported significantly improved disease-free survival (DFS) and time to progression (TTP) for R-CVP vs. CVP.

Table 14: Summary of other time to event data (includes PFS)

	M39021^{94,95}		GLSG-200^{90,91}		OSHO-39⁹²		FL2000⁹³	
	R-CVP N=162	CVP N=159	R-CHOP N=279	CHOP N=278	R-MCP N=105	MCP N=96	R-CHVPi N=175	CHVPi N=183
Median follow up	53 months		56 months		47 months		60 months	
Median PFS, months	-	-	-	-	Not reached	28.8	-	-
p-value	-		-		<0.0001		-	
Number of events	-		-		30 (29%)	50 (52%)	-	
% PFS at 4 years	-		-		71%	40%	-	
Median TTF, months	27 95% CI (25 to 37)	7 95% CI (6 to 9)	Not reached	35	-	-	-	-
p-value	<0.0001		<0.0001		-		-	
Median EFS, months	-	-	-	-	Not reached	26	Not reached	35
p-value					<0.0001		0.0004	
5 yr EFS	-	-	-	-	-	-	53% (95% CI, 45%-60%)	37% 95% CI (29%-44%)
p-value							0.001	
Median response duration, months	38, 95% CI (28 to NE)	14, 95% CI (9 to 18)	-	-	Not reached	35	-	-
p-value	<0.0001		-		<0.0001		-	
Duration of response at x years	-		66% ^a	35% ^a	-		64% ^b (95% CI, 55%-	44% ^b 95% CI (32%-

	M39021^{94,95}		GLSG-200^{90,91}		OSHO-39⁹²		FL2000⁹³	
	R-CVP N=162	CVP N=159	R-CHOP N=279	CHOP N=278	R-MCP N=105	MCP N=96	R-CHVPi N=175	CHVPi N=183
							72%)	54%)
p-value			p<0.0001 ^a				0.012 ^b	
Median months TTNT,	49, 95% CI (32 to NE)	12, 95% CI (10 to 18)	-	-	Not reached	29.4	-	-
p-value	<0.0001		0.001 ^c		0.0002		-	
Median months DFS,	Not reached, 95% CI (35 to NE)	21, 95% CI (14 to 38)	-	-	-	-	-	-
p-value	0.0001		-		-		-	
Median months TTP,	34, 95% CI (27 to 48)	15, 95% CI (12-18)	-	-	-	-	-	-
p-value	<0.0001		-		-		-	

^a Duration of response at 5 years ^b Duration of response estimated at 4 years ^c TTNT reported from median 18 month follow-up in Hiddemann et al⁹¹. Abbreviations: - not reported; DFS disease free survival; EFS event free survival; NE not estimable; PFS progression free survival; , TTF time to treatment failure; TTNT time to next antilymphoma treatment; TTP time to progression

5.2.4 Clinical effectiveness in subpopulations

Overall, rituximab and chemotherapy compared with chemotherapy alone improved treatment outcomes for all subgroups (including FLIPI score, IPI score, age, quality of response to induction therapy and other prognostic factors). It is noted that the univariate analyses presented may be misleading due to interaction between variables.

FLIPI score

All four studies presented analysis of treatment outcomes according to FLIPI score subgroups. The M39021 trial⁹⁴ found after undertaking univariate analyses that median TTP was significantly improved in the R-CVP group at 53 month follow-up for all FLIPI groups (low-, intermediate- and high-risk) (Table 15). Similarly, the GLSG-2000 study⁹⁰ found significantly prolonged 5-year TTF associated with the addition of rituximab in all FLIPI subgroups (84% vs. 46% for low-risk (p=0.0021); 73% vs. 37% for intermediate-risk (p<0.0001) and 49% vs. 23% for high-risk (p<0.0001)).

Table 15: Results of univariate analyses on TTP in M39021 trial⁹⁴ for FLIPI subgroups

Subgroup	R-CVP	CVP	P value
FLIPI 0 to 1 (low-risk)	Not reached 95% CI (38 to NE)	22 months; 95% CI (16 to 40)	0.0085
FLIPI 2 (intermediate-risk)	37 months 95% CI (28 to NE)	17 months; 95% CI (13 to 35)	0.0003
FLIPI 3 to 5 (high-risk)	26 months 95% CI (16 to 34)	11 months; 95% CI (10 to 15)	0.0004

Marcus *et al.*⁹⁴ conducted a multivariate analysis (which included the FLIPI score as a composite along with other prognostic factors that are not incorporated in the FLIPI), which found that only the FLIPI low-risk and intermediate groups combined (0 to 2) versus high risk (3 to 5) was a significant prognostic parameter for TTP in addition to trial treatment.

The MS⁶¹ presented data on the OSHO-39 trial⁹² which demonstrated that treatment with R-MCP significantly increased the 4-year PFS rate as well as prolonging the median TTP or death in patients with intermediate (p=0.0016) as well as high risk (p=0.0011) FLIPI subgroups. Amongst patients with high risk disease, a significant improvement in OS was also seen amongst those treated with R-MCP compared with MCP (p=0.0096).¹⁰⁴ No such significant improvement between treatment arms was noted for median OS for the FLIPI intermediate subgroup (p=0.8607). These data are presented in the manufacturer's submission⁶¹ and are reproduced below in Table 16; FLIPI 0-1 data were not presented.

Table 16: PFS and OS by FLIPI subgroup in the OSHO-39 trial⁹² (reproduced from MS)⁶¹

Subgroup	Parameter	MCP	R-MCP	p-value
FLIPI 2 (intermediate-risk)	Median PFS	37 months	Not reached	0.0016
	4 year PFS	43%	82%	-
FLIPI 3–5 (high-risk)	Median PFS	26.5 months	Not reached	0.0011
	4 year PFS	36%	61%	-
FLIPI 2 (intermediate-risk)	Median OS	Not reached	Not reached	0.8607
	4 year OS	90%	92%	-
FLIPI 3–5 (high-risk)	Median OS	54 months	Not reached	0.0096
	4 year OS	63%	81%	-

In the FL2000 trial,⁹³ when patients with either a low (n=65) or an intermediate (n=122) FLIPI score were grouped together, no significant difference in EFS or OS was seen between the treatment arms. However, significant improvements in 5 years EFS (p<0.001) and OS (p=0.025) were seen between the treatment arms in the high risk FLIPI subgroup. Cox regression analysis, which included the FLIPI score (low and intermediate vs. high) and the treatment arm, confirmed the impact of both parameters on EFS (FLIPI Hazard ratio [HR]= 2.08; 95% CI (1.6-2.8); and R-CHVPi treatment: HR= 0.59; 95% CI (0.44-0.78)) and OS (FLIPI: HR =4.11; 95% CI (2.34-7.23); and R-CHVPi: HR =0.67; 95% CI (0.41-1.11)).

IPI

Marcus *et al.*⁹⁴ conducted a univariate analysis of the M39021 trial data which found significantly prolonged median TTP for all IPI risk groups (see Table 17). Similarly analysis of the GLSG-2000 trial data⁹¹ found significantly prolonged TTF at 18-month follow-up by IPI-risk group (Table 18).

Table 17: Median TTP by IPI subgroup in the M39021 trial⁹⁴

Subgroup	Parameter	R-CVP	CVP	P value
IPI 0 to 1 (low-risk)	Median TTP	44 months 95% CI (30 to NE)	20 months; 95% CI (13 to 26)	<0.0001
IPI 2 (intermediate-risk)	Median TTP	27 months 95% CI (20 to 39)	14 months; 95% CI (10 to 17)	0.0003
IPI 3 to 4 (high-risk)	Median TTP	40 months 95% CI (11 to NE)	12 months; 95% CI (8 to 25)	0.0333

Table 18: Median TTF by IPI subgroup in the GLSG trial⁹¹

Subgroup	Estimated median TTF for CHOP	p-value for Cox regression	Estimated relative risk for treatment failure for R-CHOP (95% CI)
IPI 1-2	Not reached	0.001	0.412 (0.242-0.701)
IPI 3-5	29 months	0.009	0.331 (0.144-0.761)

Age

Eighteen month follow-up data in the GLSG-2000 trial⁹¹ found that TTF was prolonged in the R-CHOP arm for patients of any age. The relative risk of treatment failure in the R-CHOP arm compared with the CHOP arm was 0.417, 95% CI (0.233-0.747) for patients <60 years and was 0.354, 95% CI (0.175-0.715) for patients ≥60 years.

Table 19: Median TTF by age subgroup (<60 years versus ≥60 years) in GLSG-2000 trial⁹¹

Age	Estimated median TTF for CHOP ^a	p-value for Cox regression	Estimated RR for treatment failure for R-CHOP (95% CI)
<60 years	Not reached	0.003	0.417 (0.233-0.747)
≥60 years	29 months	0.004	0.354 (0.175-0.715)

^a Median not reached for R-CHOP arm for < 60years or ≥60 years

Quality of response

Salles *et al.*⁹³ analysed the response duration for the subgroup of patients who were in CR/CRu at 18 months of treatment in the FL2000 trial. The response duration was significantly different between the two treatment arms, with 4-year estimates of 44% (95%CI, 32%-54%) versus 64% (95% CI, 55%-72%) in the CHVPi and R-CHVPi arms, respectively (p =0.012). Therefore, as well as rituximab and chemotherapy increasing the number of CR/CRus, patients are also more likely to have a longer response duration.

Other prognostic factors

Marcus *et al.*⁹⁴ conducted several univariate analyses for a number of prognostic factors (Table 20) in the M39021 trial. The R-CVP treatment arm was associated with a significant prolonged TTP when compared with CVP alone for all subgroups investigated including baseline histology, presence or absence of B-symptoms, and presence or absence of bulky disease. A significant improvement in TTP was seen in patients with baseline only haemoglobin of at least 12 g/dL; however no difference in TTP was observed between the R-CVP and CVP arms in patients with baseline haemoglobin < 12g/dL (p=0.3941).

Table 20: Univariate analyses in the M39021 trial⁹⁴

Subgroup	R-CVP	CVP	P value
Histology at central review (IWF): Class B	34 months 95% CI (27 to NE)	17 months 95% CI (11 to 24)	0.0037
Histology at central review (IWF): Class C	35 months 95% CI (26 to NE)	15 months 95% CI (10 to 21)	<0.0001
Histology at central review (IWF): Class D	Not reached 95% CI (30 to NE)	14 months 95% CI (7 to 24)	0.0046
B symptoms^a ≥1	32 months 95% CI (22 to NE)	17 months 95% CI (12 to 23)	0.0014
No B symptoms^a	37 months 95% CI (26 to 48)	14 months 95% CI (11 to 20)	<0.0001
Bulky disease- yes	38 months 95% CI (25 to 48)	13 months 95% CI (11 to 21)	<0.0001
Bulky disease- no	32 months 95% CI (26 to NE)	16 months 95% CI (13 to 21)	<0.0001
Haemoglobin ≥ 12g/dL	39 months 95% CI (31 to NE)	17 months 95% CI (13 to 22)	<0.0001
Haemoglobin < 12g/dL	11 months 95% CI (9 to 28)	12 months 95% CI (10 to 16)	0.3941

^a B symptoms defined as fever weight loss, and night sweats

Marcus *et al.*⁹⁴ also undertook two multivariate analyses: one which included the IPI as a composite along with other prognostic factors not incorporated in the IPI; one which included the individual factors which make up the FLIPI and IPI together with other prognostic factors. These analyses found that only haemoglobin level (<12 g/DL) and number of nodal areas involved (>1) were statistically significant predictors of TTP in addition to trial treatment.

Buske *et al.*¹⁰⁵ conducted a multivariate analysis on the GLSG-2000 trial data at 20-month follow-up including the individual FLIPI risk factors. This found that a serum LDH level higher than the upper normal limit (Relative risk (RR) 2.6; 95% CI 1.5 to 4.5) and a haemoglobin level below 12 g/dL (RR 2.5; 95% CI 1.4 to 4.3) were independently associated with a shorter TTF in addition to trial treatment. However, age, (≥ 60 years versus < 60 years RR 0.9; 95% CI 0.5 to 1.5) and the number of nodal areas (>4 versus ≤ 4 ; RR 1.5; 95% CI 0.8 to 2.6) did not significantly influence the TTF.

5.2.5 Meta-analysis

Three exploratory meta-analyses were conducted to explore the results of synthesising the ORR, CR and PR from the four trials.

There were several problems with the validity of these analyses. Firstly, the level of statistical heterogeneity calculated in RevMan⁸⁹ using the I^2 statistic was very high (range $I^2=56-88\%$). The I^2 describes the percentage of the variability in effect estimates that is due to heterogeneity rather than sampling error (chance),¹⁰⁶ and an $I^2 > 50\%$ is considered to be a high enough level of heterogeneity to suggest meta-analysis is not appropriate. Ideally, this high level of heterogeneity would be explored further and explained by estimating the predictive distribution of a new study. This was not undertaken due to resource constraints.

Reasons for the high level of heterogeneity could be due to differences in treatment effects in the four trials. Examination of the confidence intervals for the results from the individual trials showed that there was little overlap in the meta-analyses for CR, and to a lesser extent for PR, indicating evidence for heterogeneity of intervention effects. Indeed, the GLSG-2000 trial^{91,90} observed much higher ORR (a combination of CR and PR) for both the R-chemotherapy and chemotherapy alone arms in comparison to the other studies. This was mostly accounted for by an increase in the numbers of PR (20% CR and 77% PR in the R-CHOP arm), whereas in the OSHO-39 trial⁹² there was a more even split between the CR/PR categories (R-MCP CR=50% and PR=43%). As well as evidence for different intervention effects in the four trials, there are other possible explanations for the high level of heterogeneity. Firstly, each study administered a different therapeutic intervention with

respect to the chemotherapy regimen used; this included different chemotherapeutic agents (CVP, CHOP, MCP and CHVPi) and different regimens of treatment (three weekly versus four weekly cycles, 6 cycles of treatment versus 8 cycles of treatment). Secondly, there was a difference in the sample sizes of the studies; for example the GLSG-2000 trial^{90,91} was the largest trial with an intention-to-treat population of n=557 patients whilst the OSHO-39 trial⁹² was substantially smaller (n=201).

The AG also notes that the choice of chemotherapeutic regimen is not solely determined by clinical efficacy. For example, R-CHOP is less likely to be given to patients who are elderly or unfit, whilst more likely to be given to treat aggressive or bulky disease, which may impact on the perceived efficacy. Additionally, the analyses assume that rituximab has no synergistic interaction with the chemotherapeutic component of a regimen for the treatment effect. The AG also comment that the analyses of ORR, CR and PR are not independent analyses given the same patients are counted in more than one analysis.

The AG therefore believes the response rates from the individual trials to be a more robust estimator of the efficacy of the specific R-chemotherapy regimens. These are subsequently used in the decision model (see section 6) rather than meta-analysed response rates. The results from the meta-analyses are presented in Appendix 14 for completeness, but the use of these are strongly cautioned against.

5.2.7 Safety data

The evaluation of the safety of rituximab and chemotherapy is mainly derived from data reported from the four included trials,^{90,91,92,93,94} which are described in section 5.2.2 (Summary of trials) . The adverse events data were extracted from the four trials (see Appendix 11 for completed data extraction forms). In addition, post-marketing surveillance data presented in the MS are presented.⁶¹

The M39021, OSHO-39 and FL2000 trials^{92,93,94,95} graded adverse events in accordance with the National Cancer Institute Common Toxicity Criteria (NCI-CTC) grading system;⁹⁹ but the GLSG-2000 trial^{90,91} used the WHO toxicity criteria¹⁰⁰ to record adverse events. However, there are no substantial differences between these two scales.¹⁰⁷

Treatment completion and withdrawals

The M39021, OSHO-39 and FL2000 trials^{195,94,92,93 95} reported data on the number of treatment cycles that were completed. No data were presented on the planned cycle completion, doses of study drugs administered and withdrawal numbers or reasons in the GLSG-2000 trial.^{90,91}

Overall, a greater proportion of patients in the R-chemotherapy arms received the planned number of cycles when compared with the chemotherapy alone arm (Table 21). No differences in dose of chemotherapy received were noted between the R-chemotherapy and chemotherapy alone arms, with the exception of cyclophosphamide in the M39021 trial.^{95,94} Reasons for withdrawal from treatment appeared to be mostly due to disease progression or treatment failure (for example failing to achieve a response to treatment after a defined number of cycles). However, there was a lack of transparency in the studies regarding withdrawals for other reasons such as adverse events/reactions. This is considered in more detail by trial.

Table 21: Number of treatment cycles administered

	M39021 ^{94,95}		GLSG-2000 ⁹¹		OSHO-39 ⁹²		FL2000 ⁹³	
	R-CVP N=162	CVP N=159	R-CHOP N=223	CHOP N=205	R-MCP N=105	MCP N=96	R-CHVPi N=175	CHVPi N=183
Patients who received planned number of cycles N (%)	137 (85)	108 (68)	NR	NR	92 (88)	64 (67)	166 (95)	172 (94)

NR=not reported

M39021 trial

A CONSORT diagram¹⁰⁸ was reported for the M39021 trial,^{94,95} which showed the flow of patients through the trial. This showed that 137/162 (85%) of patients in the R-CVP arm and 108/159 (68%) patients in the CVP arm completed 8 cycles.^{94,95} The MS⁶¹ provided further details on cycle completion, with 6/162 (4%) of patients in the R-CVP arm withdrawn before cycle 4 compared with 13/159 (8%) in the CVP arm. Thus, 19/162 (12%) patients in the R-CVP arm were withdrawn after cycle 4 compared with 38/159 (24%) in the CVP arm. The majority of patients appear to have been withdrawn due to an insufficient treatment response (defined as disease progression or stable disease after cycle 4). However, a number of patients were withdrawn before cycle 4 for which the reasons are not made explicit. The authors note that two patients were withdrawn as a result of grade 3 or 4 rituximab infusion-related reactions and one patient withdrew consent and thus withdrew from the trial; however this does not account for all patients.

Marcus *et al.*⁹⁵ report the proportion of patients in the M39031 trial who received the planned doses of chemotherapy. The proportion of patients that received more than 90% of the planned dose of prednisolone and vincristine at each administered cycle was comparable between the R-CVP and CVP arms. However, the proportion of patients who received more than 90% of cyclophosphamide was higher in the CVP group (>94%) than the R-CVP group (> 85%). The authors state that this was ‘mainly due to dose modifications in the R-CVP group for NCI-CTC grades 3 and 4 neutropenia’. Clinical advice suggests this is now less of a problem since granulocyte stimulating factor (GSF) is routinely used to treat neutropenia. Ninety-six percent of patients received more than 90% of the planned dose of rituximab at each administered cycle.⁹⁵

OSHO-39 trial

In the OSHO-39 trial,⁹² 88% of patients in the R-MCP arm and 67% in the MCP arm completed all 8 cycles of treatment. Treatment failure due to disease progression after two cycles occurred in three patients in the R-MCP arm and in 10 patients in the MCP arm. Failure to achieve at least a partial response after 6 cycles occurred in 7 patients in the R-MCP arm and 22 patients in the MCP arm. Numbers of patient withdrawals (n=16) prior to the study drug administration and the associated reasons were reported; however this includes patients with mantle cell lymphoma as well as FL. The authors state that all other withdrawals were due to non-response/treatment failure during therapy (which was defined as disease progression after two cycles of therapy or failure to reach a PR or CR after six cycles of therapy). The authors do not state if there were any withdrawals due to adverse events or reactions.

The mean dose of study drugs administered in the OSHO-39 trial⁹² were rituximab, 660–680 mg/cycle; mitoxantrone, 228 mg/cycle; chlorambucil, 681 mg/cycle and prednisolone, 226231 mg/cycle. The authors stated that the dose intensity of the chemotherapy did not differ between treatment arms.⁹² Interferon- α maintenance treatment (3 x 4.5 MIU per week until disease progression) was initiated in 97% and 92% of responding patients in the R-MCP and MCP arms, respectively.

FL2000 trial

In the FL2000 study,⁹³ the MS⁶¹ noted that 95% of patients in the R-CHVPi arm and 94% of patients in the CHVPi arm received the initial 6 cycles of treatment. Amongst patients who did not progress during therapy, 161 (98%) and 153 (98%) of the patients received the planned chemotherapy courses during the first 6 months in the R-CHVPi and CHVPi arms,

respectively. In the CHVPi arm, 116 (87%) of 134 patients without death or progression received the 6 planned cycles of chemotherapy consolidation; the R-CHVPi arm did not receive this chemotherapy consolidation. Two hundred and thirty-seven (66%) patients followed the interferon treatment according to the protocol, with dose adaptation (45 patients) or short (less than 4 weeks) interruptions (55 patients), without significant differences in adaptation between the 2 study arms. In addition, interferon treatment was stopped in 50 patients resulting from disease progression (R-CHVPi arm, 19 cases and CHVPi arm, 31 cases, respectively) and was interrupted either for more than 1 month (16 cases) or definitively (72 cases) resulting from toxicity. These major interruptions were observed in 41 patients in the RCHVPi arm and 47 patients in the CHVPi arm. One patient withdrew consent after registration, and one patient had a major inclusion violation (registered at relapse) and thus were withdrawn from the treatment in the FL2000 trial.⁹³ No further details are provided on withdrawals in the FL2000 trial⁹³ during treatment; although not all patients received the planned 6 cycles of initial treatment.

Adverse events of any grade

Adverse events of any grade were reported as more frequent in the R-MCP arm than in the MCP arm in the OSHO-39 trial⁹² (99% vs. 86% of patients, respectively). However the M39021 trial^{94,95} reported that the proportion of patients that reported at least one adverse event was comparable between the CVP (95%) and R-CVP (97%) groups. Marcus *et al.*⁹⁵ report that adverse events associated with the gastrointestinal and nervous systems as well as general disorders and administration site reactions were the most commonly occurring types of events in both treatment groups in the M39021 trial. Fatigue, neutropenia, and back pain were the most common severe adverse events and occurred at a slightly higher frequency in patients receiving R-CVP. These data were not available within the manuscripts^{94,95} reporting on the M39201 trial but appear to be confirmed by data presented in the MS⁶¹ which reports on all grades of adverse events in the M39201 trial.

Grade 1 and 2

The OSHO-39⁹² and GLSG-2000⁹¹ trials reported grade 1 and 2 adverse events. The authors in each trial reported that there were no significant differences between the treatment arms. The most common grade 1/2 adverse event in the OSHO-39 trial⁹² study was infection which affected 42% of patients receiving R-MCP, and 35% receiving MCP. In the GLSG-2000 trial,⁹¹ the most commonly reported grade 1/2 adverse event was low haemoglobin level with 50% of R-CHOP, and 49% of CHOP patients affected. Neurotoxicity was another frequent grade 1 or 2 adverse event reported in the GLSG-2000 trial⁹¹ (R-CHOP 34% and CHOP 42%). Reduced platelet count was also a common adverse event, especially in the OSHO-39

trial⁹² (R-MCP 30%, MCP 33%), whilst the GLSG-2000 trial⁹¹ reported lower incidences for patients receiving the CHOP based treatments (R-CHOP 17%, CHOP 16%). Nausea and vomiting was another frequent grade 1 or 2 adverse event in both trials (R-CHOP 45%, CHOP 44% in the GLSG-2000 trial and R-MCP 24%, MCP 15%).⁹² For a detailed list of grade 1 and 2 adverse events see Table 22.

Table 22: Adverse events (grade 1 and 2) reported in the GLSG-2000⁹¹ and OSHO-39⁹² trials^a (Grade 1/2 adverse events not reported in M39021 trial and FL2000 trial)

Adverse events: N (%)	GLSG-2000 ^{91 b}		OSHO-39 ^{92 c}	
	R-CHOP N=223	CHOP N=205	R-MCP N=105	MCP N=96
Low haemoglobin level	112 (50)	100 (49)	18 (17)	18 (19)
Leukocytopenia	54 (24)	57 (28)	3 (3)	8 (8)
Granulocytopenia	42 (19)	41 (20)	-	-
Reduced platelet count	38 (17)	33 (16)	31 (30)	32 (33)
Infection	74 (33)	59 (29)	44 (42)	34 (35)
Bleeding	9 (4)	6 (3)	-	-
Nausea/vomiting	100 (45)	90 (44)	25 (24)	14 (14)
Stomatitis	58 (26)	59 (29)	11 (10)	7 (7)
Obstipation (severe constipation)	33 (15)	27 (13)	-	-
Diarrhoea	25(11)	23 (11)	11 (10)	4 (4)
Fever	65 (29)	45 (22)	-	-
Cardiac dysfunction	7 (3)	8 (4)	-	-
Alopecia	42 (19)	51 (25)	-	-
Cardiac arrhythmia	13 (6)	8 (4)	-	-
Neurotoxicity	76 (34)	86 (42)	-	-
CNS toxicity	4 (2)	4 (2)	-	-
Allergy	13 (6)	0 (0)	-	-
Rash	-	-	16 (15)	1 (1)
Heartburn	-	-	15 (14)	3 (3)
Insomnia	-	-	15 (14)	7 (7)
Bone pain	-	-	10 (10)	10 (10)
Gastro-intestinal	-	-	9 (9)	5 (5)
Other (not specified)	-	-	11 (10)	8 (8)

^a Numbers and percentage may not add up due to rounding ; ^b Not stated if number of patients reporting each event or overall number of events ; ^c Authors state that data is the number of patients reporting each event (not stated if a patient could be counted more than once); - not reported

Grade 3 and 4 adverse events

All four studies reported grade 3 and 4 adverse events; the GLSG-2000⁹¹ and OSHO-39⁹² trials reported grade 3 and 4 adverse events separately whereas the M39021^{94,95} and FL2000⁹³

trials combined the numbers of grade 3 or 4 adverse events. The most common adverse events observed in the four trials were related to the blood and bone marrow, including leukocytopenia, neutropenia and granulocytopenia. For two trials, the most common grade 3 and 4 adverse events were reduced leukocyte (white blood cell) levels; this was observed in 69% of R-CHOP and 61% CHOP patients in the GLSG-2000 trial⁹¹ and 72% R-MCP and 58% MCP patients in the OSHO-39 trial.⁹² The statistical significance of the difference in grade 3/4 leukopenia between the treatment arms in the OSHO-39 trial⁹² was not reported by the authors, whilst the difference between the R-CHOP and CHOP treatment arms in the GLSG-2000 trial⁹¹ was reported as not significant.

The most common adverse event in the M39021 trial^{94,95} was neutropenia (24% in R-CVP and 14% in CVP arms); however the authors do not state if this was a statistically significant difference between treatment arms. In the FL2000 trial,⁹³ the most common grade 3/4 adverse event was neutrophil toxicity (59% R-CHVPi and 62% in CHVP arms). However, the FL2000 trial⁹³ only noted a significant difference in grade 3 or 4 adverse events for neutrophil toxicity during the 12 month consolidation period which was more frequent in the chemotherapy alone arm than the rituximab containing arm ($p < 0.001$) (results presented in the data extraction form for the FL2000 trial⁹³ in Appendix 11).

There were a number of patients who had a low granulocyte count of grade 3 or 4 severity in the GLSG-2000 trial⁹¹ and the difference between the treatment arms was statistically significant (R-CHOP 63%; CHOP 53%, < 0.01). In addition, Grade 3 or 4 alopecia was a frequently observed adverse event in both arms of the GLSG-2000 trial⁹¹ (R-CHOP 67%; CHOP 61%).

Blood or bone marrow adverse events may be associated with infection. However, the difference in frequency of blood or bone marrow adverse events between treatment arms is of minor clinical significance as they did not translate into a difference in infection rates between the treatment arms for all three studies. Infections of grade 3 or 4 were observed in 8% of the MCP group and 7% of the R-MCP group; 5% R-CHOP and 7% CHOP arm and 2% of the R-CHVPi arm and 0% CHVPi arm.^{91,92,93} The MS⁶¹ reports all grades of infections for three trials which follows a similar pattern (R-CVP 33% and CVP 32%; 38% R-CHOP and 36% CHOP; 49% R-MCP and 43% MCP).

More detail on grade 3/4 adverse events combined for the four trials and grade 3 or 4 adverse events reported separately (only for the GLSG-2000⁹¹ and OSHO-39⁹² trials) are reported in Table 23 and Table 24 respectively.

Table 23: Adverse events (grade 3 and 4 combined) for all four trials^a

	M39021^{94,95}		GLSG-2000⁹¹		OSHO-39⁹²		FL2000^{93 b}	
Adverse events: N (%)	R-CVP N=162	CVP N=159	R- CHOP N=223	CHOP N=205	R- MCP N=105	MCP N=96	R-CHVPi N=175	CHVPi N=183
Low haemoglobin level	-	-	20 (9)	21 (10)	3 (3)	4 (4)	6 (3)	9 (5)
Leucocytopenia ^c	19 (12)	14 (9)	154 (69)	125 (61)	75 (72)	56 (58)	-	-
Neutropenia	39 (24)	22 (14)	-	-	-	-	103 (59)	114 (62)
Granulocytopenia	-	-	140 (63)	109 (53)	-	-	-	-
Reduced platelet count	-	-	13 (6)	16 (8)	4 (4)	7 (7)	5 (3)	6 (3)
Bleeding	-	-	0 (0)	0 (0)	-	-	-	-
Nausea/vomiting	-	-	9 (4)	12 (6)	1 (1)	6 (6)	-	-
Stomatitis	-	-	2 (1)	4 (2)	1 (1)	1 (1)	-	-
Obstipation (severe constipation)	-	-	4 (2)	2 (1)	-	-	-	-
Diarrhoea	-	-	4 (2)	6 (3)	2 (2)	2 (2)	-	-
Fever	-	-	0 (0)	2 (1)	-	-	2 (1)	2 (1)
Alopecia	-	-	149 (67)	125 (61)	-	-	-	-
Infection	-	-	11 (5)	14 (7)	7 (7)	8 (8)	4 (2)	0 (0)
Cardiac dysfunction	-	-	7 (3)	2 (1)	-	-	2 (1)	3 (2)
Cardiac arrhythmia	-	-	4 (2)	0 (0)	-	-	-	-
Neurotoxicity	-	-	2 (1)	4 (2)	-	-	-	-
CNS toxicity	-	-	2 (1)	0 (0)	-	-	-	-
Allergy	-	-	2 (1)	0 (0)	-	-	-	-
Rash	-	-	-	-	0	2 (2)	-	-
Heartburn	-	-	-	-	1 (1)	0 (0)	-	-
Insomnia	-	-	-	-	0 (0)	0 (0)	-	-
Bone pain	-	-	-	-	2 (2)	0 (0)	-	-
Gastro-intestinal	-	-	-	-	2 (2)	2 (2)	-	-
Other	-	-	-	-	0 (0)	2 (2)	-	-

^a Numbers and percentage may not add up due to rounding; ^b Adverse events recorded from first 6 months of treatment. Adverse events from consolidation treatment phase (additional 12 months) available in the data extraction form in Appendix 11. ^c Data for the M39201 trial taken from the MS⁶¹ and could not be confirmed in the manuscripts.

Table 24: Adverse events (grade 3 and 4 separately) reported in the GLSG-2000⁹¹ and OSHO-39⁹² trials

(Grade 3/4 adverse events not reported separately in the M39021 trial^{94,95} and FL2000⁹³ trial)

	GLSG-2000 ⁹¹				OSHO-39 ⁹²			
	Grade 3		Grade 4		Grade 3		Grade 4	
Adverse events: N (%)	R-CHOP N=223	CHOP N=205	R-CHOP N=223	CHOP N=205	R-MCP N=105	MCP N=96	R-MCP N=105	MCP N=96
Haemoglobin level	18 (8)	18 (9)	2 (1)	2 (1)	2 (2)	3 (3)	1 (1)	1 (1)
Leukocyte/ white blood cells	96 (43)	78 (38)	58 (26)	47 (23)	25 (24)	21 (22)	50 (48)	35 (36)
Granulocyte count	49 (22)	47 (23)	91 (41)	62 (30)	-	-	-	-
Platelet count	9(4)	10 (5)	4 (2)	6 (3)	4 (4)	6 (6)	0 (0)	1 (1)
Bleeding	0 (0)	0 (0)	0 (0)	0 (0)	-	-	-	-
Nausea/vomiting	9 (4)	12(6)	0 (0)	0(0)	1 (1)	6 (6)	0 (0)	0 (0)
Stomatitis	2 (1)	4 (2)	0 (0)	0(0)	1 (1)	1 (1)	0 (0)	0 (0)
Obstipation (severe constipation)	4(2)	2 (1)	0 (0)	0(0)	-	-	0 (0)	0 (0)
Diarrhoea	4 (2)	6 (3)	0 (0)	0 (0)	2 (2)	0 (0)	0 (0)	2 (2)
Fever	0 (0)	2 (1)	0 (0)	0 (0)	-	-	-	-
Alopecia	140 (63)	115 (56)	9 (4)	10 (5)	-	-	-	-
Infection	11 (5)	12 (6)	0 (0)	2 (1)	6 (6)	7 (7)	1 (1)	1 (1)
Cardiac dysfunction	4 (2)	2(1)	2 (1)	0 (0)	-	-	-	-
Cardiac arrhythmia	2 (1)	0 (0)	2 (1)	0 (0)	-	-	-	-
Neurotoxicity	2 (1)	4 (2)	0 (0)	0 (0)	-	-	-	-
CNS toxicity	2 (1)	0 (0)	0 (0)	0 (0)	-	-	-	-
Allergy	2 (1)	0 (0)	0 (0)	0 (0)	-	-	-	-
Rash	-	-	-	-	0 (0)	2 (2)	0 (0)	0 (0)
Heartburn	-	-	-	-	1 (1)	0 (0)	0 (0)	0 (0)
Insomnia	-	-	-	-	0 (0)	0 (0)	0 (0)	0 (0)
Bone pain	-	-	-	-	2 (2)	0 (0)	0 (0)	0 (0)
Gastro-intestinal	-	-	-	-	2 (2)	1 (1)	0 (0)	1 (1)

	GLSG-2000 ⁹¹				OSHO-39 ⁹²			
	Grade 3		Grade 4		Grade 3		Grade 4	
Adverse events:	R-CHOP	CHOP	R-CHOP	CHOP	R-MCP	MCP	R-MCP	MCP
N (%)	N=223	N=205	N=223	N=205	N=105	N=96	N=105	N=96
Other	-	-	-	-	0 (0)	1 (1)	0 (0)	1 (1)

Infusion-related reactions

Infusion-related reactions were observed in 7% of courses during the first infusion in the GLSG-2000 trial⁹¹ and early cessation of rituximab therapy was required in 2 patients. Fourteen (9%) patients in the M39201 trial^{94,95} had a grade 3 or 4 rituximab infusion-related reaction, and two of these patients were withdrawn from study treatment. More patients in the R-CVP group than in the CVP group experienced an adverse event within 24 hours of an infusion (71% vs. 51%, respectively). One grade 3 infusion-related reaction was reported in the OSHO-39 trial in the MS⁶¹ and related to the full study population of FL and MCL.

Death and life-threatening adverse events

Overall, there were very few adverse events reported as life-threatening or leading to death within the trials. The M39201 trial^{94,95} reported that five patients experienced a total of six life-threatening events following R-CVP; however no treatment-related deaths occurred. The remaining three studies did not report whether adverse events were either life-threatening or led to death.

The number of deaths reported for the chemotherapy alone arms were consistently higher compared with the R-chemotherapy arms in all four trials. A total of 49 deaths were reported in the M39201 trial from 30-month follow-up⁹⁵ (21 in the R-CVP arm and 28 in the CVP arm, patients may have received second-line therapy at this stage). Twenty-three deaths (17 CHOP and 6 R-CHOP) and 40 deaths (25 MCP and 15 R-MCP) occurred in study GLSG-2000⁹¹ and study OSHO-39⁹², respectively. In the FL2000 trial,⁹³ a total of 45 patients had died at the time of the analysis at 42 months (R-CHVPi 16 and CHVPi 29). The majority of deaths were attributed to lymphoma progression. The GLSG-2000 study⁹¹ reported the additional reasons for death in detail (Table 25); however the other three trials did not report this information.

Table 25: Number of deaths and reasons for death in the four trials.

	M39021^{95 a}		GLSG-2000^{91 b}		OSHO-39⁹²		FL2000^{93 c}	
	R-CVP N=162	CVP N=159	R-CHOP N=223	CHOP N=205	R- MCP N=105	MCP N=96	R-CHVPi N=175	CHVPi N=183
Total numbers (%) of deaths	21(13)	28(18)	6	17	15 (14)	25 (26)	16	29
Reasons for death								
Lymphoma/progressive disease	13(8)	22(14)	1(0)	9(4)	7	17	-	-
Infection	-	-	4(2)	4(2)	-	-	-	-
Cardiac failure	-	-	0	1(0)	-	-	-	-
Apoplectic insult	-	-	0	1(0)	-	-	-	-
GVHD after ASCT	-	-	0	1(0)	-	-	-	-
Cause unknown	-	-	1(0)	1(0)	-	-	-	-

^a Data from 30-month follow-up; ^b Data from 18-month follow-up ^c Data from MS.⁶¹ GHVD=Graph versus host disease; SCT= allogeneic stem cell transplantation, - not reported

Subgroup analyses

The MS⁶¹ reported data on the safety from the GLSG-2000 trial⁹¹ for the elderly population (≥ 60 years of age, N=221). As for the whole trial population, the most common adverse events were blood and bone marrow disorders, gastrointestinal disorders, skin toxicities, neurological disorders, cardiac disorders, infections and fever. Most of the adverse events were mild to moderate in intensity except for alopecia, leukopenia and neutropenia, which were mainly of Grade 3/4 in intensity. The most common Grade 3/4 AEs in the elderly population were blood and bone marrow disorders and alopecia. The remaining three trials did not provide adverse event data for subgroup populations.

Post-Marketing Data (taken from the MS)⁶¹

Over one million patients (length of exposure not known), predominately NHL patients, have received rituximab since its first marketing authorisation. World wide safety data submitted to the Periodic Safety Update Reports (PSURs) (with a cut-off date of April 2007) has recorded 13,008 adverse events. Of these reported AEs, 10,184 were classified as serious. For 7,174 events, the report came from spontaneous sources (post-marketing experience). Other sources include clinical trials in oncology and rheumatoid arthritis (company-sponsored and investigator-sponsored trials). The MS⁶¹ presents a summary of adverse events in the global safety database for rituximab (as of 30th April 2007) and this is presented in Table 26. The most frequently reported events were infection and infestation (15%), blood and lymphatic system disorders (14%), general disorders and administration site conditions (11%) and respiratory, thoracic and mediastinal disorders (10%).

The updated summary of product characteristics from the EMEA⁸² also discusses cases of Progressive multifocal leukoencephalopathy (PML) being associated with the use of rituximab. All patients treated with MabThera for rheumatoid arthritis must be given a patient alert card with each infusion, which contains important safety information for patients including signs and symptoms to watch out for. However, cases of PML reported during post-marketing use of rituximab in NHL are very rare (numbers/percentages are not reported).

Table 26: Adverse events in the global rituximab safety database as of April 30, 2007 (all sources and indications): reproduced from the MS⁶¹

System Organ Class	SAE	% SAE	Total AEs	% Total AEs
Blood and lymphatic system disorders	1,586	16	1,775	14
Cardiac disorders	566	6	604	5
Congenital, familial and genetic disorders	9	0	10	0
Ear and labyrinth disorders	31	0	44	0
Endocrine disorders	13	0	15	0
Eye disorders	61	1	106	1
Gastrointestinal disorders	601	6	767	6
General disorders and administration site conditions	770	8	1,400	11
Hepatobiliary disorders	163	2	165	1
Immune system disorders	399	4	480	4
Infections and infestations	1,852	18	1,986	15
Injury, poisoning and procedural complications	177	2	281	2
Investigations	433	4	603	5
Metabolism and nutrition disorders	118	1	137	1
Musculoskeletal and connective tissue disorders	331	3	523	4
Neoplasms benign, malignant and unspecified (including cysts and polyps)	495	5	513	4
Nervous system disorders	454	4	611	5
Pregnancy, puerperium and perinatal conditions	15	0	30	0
Psychiatric disorders	58	1	78	1
Renal and urinary disorders	174	2	188	1
Reproductive system and breast disorders	26	0	44	0
Respiratory, thoracic and mediastinal disorders	1,136	11	1,348	10
Skin and subcutaneous tissue disorders	271	3	711	5
Social circumstances	6	0	8	0
Surgical and medical procedures	47	0	51	0
Vascular disorders	392	4	530	4
Total	10,184	100	13,008	100

AE, adverse event; SAE, serious adverse event.

Discussion

The results from four randomised trials (of good quality) comparing the combination of rituximab and chemotherapy with chemotherapy alone showed an improvement in a number of clinical effectiveness outcomes. This included trials evaluating R-CVP,^{94,95} R-CHOP,^{90,91} R-MCP⁹² and R-CHVPi⁹³ in each case against their respective chemotherapy regimen.

Evidence from the four trials on the primary outcome of interest in this appraisal, OS, showed a benefit for rituximab and chemotherapy compared with chemotherapy alone, for all chemotherapy regimens. The difference in OS rates ranged from 6% to 14% when the R-chemotherapy arms was compared with the chemotherapy alone arms. The difference in OS rates was statistically significant in three trials; the exception being the FL2000 trial⁹³ ($p=0.1552$). However, the follow-up period for the four trials is approximately 4 to 5 years and the median OS has yet to be reached for each arm (intervention and comparator) within each trial. The median survival of FL is reported as 8-10 years,²⁸ although some have commented that this figure has increased in the last decade,^{14,15} and thus the evidence for the effect of R-chemotherapy on OS might be strengthened by a longer follow-up period. It is also noted that data in three trials is confounded by additional trial treatments (interferon- α maintenance/consolidation and SCT, for further details see section 5.2.2) which needs to be considered when interpreting the OS and other time to event data. However, given the relapsing and remitting nature of FL, it is unlikely that a trial could be ethically undertaken to remove the effect of subsequent therapies i.e. when a patient relapses they will receive subsequent treatment to induce remission.

Progression-free survival was measured only in the OSHO-39 trial⁹² and was significantly prolonged for the R-chemotherapy arm (R-MCP) (median: 28.8 months for MCP and not reached for R-MCP, $p<0.0001$). Other time to event data such as event-free survival, time to progression and time to next anti-lymphoma treatment showed similar benefits in effect; although these were inconsistently defined and not directly comparable between trials.

Overall response rates (ORR) were significantly improved in all four trials, with a difference in 5% to 24% between the R- chemotherapy and chemotherapy arms. CR rates were also improved, with a difference between the R- chemotherapy and chemotherapy arms of 2- 25%, which was reported as significant in three studies (the GLSG-2000 trial of R-CHOP vs. CHOP did not report a p value). Differences in PR rates were generally smaller (level of significance not reported); however this might be explained by a potential way R-chemotherapy shifts patients from non-responders to partial responders and partial responders to complete responders. There was some evidence that the response quality differed amongst

the four R-chemotherapy combinations. For example, greater ORR was observed in the GSLG-2000 trial^{109,90} (R-CHOP vs. CHOP) compared with the M39021 trial (R-CVP vs. CVP), whilst CR rates were greater in the M39021 trial^{95,94} than the GLSG-2000 trial.^{91,90} Others have noted these differences between R-chemotherapy regimens.⁷⁹ Clinical advice to the AG noted that R-CHOP/CHOP is reserved for more aggressive disease, and this would have implications on the quality of response. However, the baseline characteristics of the patients were generally similar in each of the four trials.

Considerable statistical heterogeneity was observed in exploratory meta-analyses undertaken to provide a summary of effect of response rates. Differences in treatment effects, study sample sizes and chemotherapeutic agents and regimens are plausible reasons for this heterogeneity. Due to the high level of heterogeneity, meta-analysis of response rates is not considered appropriate. Thus, response rate results from individual studies are considered more robust.

The safety data shows that the addition of rituximab to chemotherapy does not result in clinically relevant adverse outcomes. Whilst an increased statistically significant incidence of leukocytopenia, neutropenia and granulocytopenia were observed in the trials in the R-chemotherapy arms, this was of limited clinical significance as the rate of infection did not increase in the R-chemotherapy arms (infection is associated with leukocyto-, neutro- and granulocytopenia). However, considerable numbers of patients were affected by grade 3 or 4 alopecia in both the R-CHOP and CHOP arms of the GSLG-2000 trial. This side effect is as a result of the CHOP component of the treatment and is an important side effect to consider particularly in terms of patient acceptance, tolerance and choice.

It is noted that the median age of patients within the trials (52 to 61 years) is considerably younger than that seen in clinical practice, where over 70% are aged over 60 years at diagnosis and clinical advice suggests that the ECOG performance status is better than that seen in UK clinical practice.¹⁰ This affects the generalisability of the findings to the clinical FL population; however limited analyses undertaken within the trials did not show a differential affect for different clinical and demographic subgroups. Specifically, the GSLG-2000 showed that adding rituximab to chemotherapy was beneficial for both over and under 60-year olds.

Our own searches of the randomised evidence were exhaustive and we are confident that we have not missed any published reports of RCTs or other systematic reviews of R-chemotherapy in the treatment of FL.

In conclusion, the addition of rituximab to chemotherapy results in better clinical outcomes for patients when compared with chemotherapy alone, for all chemotherapeutic backbones examined in this review, i.e. CVP, CHOP, MCP and CHVPi. This is achieved with minimal additional adverse events or toxicity which are deemed to be clinically relevant.

6. ASSESSMENT OF COST-EFFECTIVENESS

6.1 Systematic review of existing cost-effectiveness evidence

This section of the report describes a review of the existing evidence on the cost-effectiveness of the addition of rituximab to chemotherapy in patients with untreated, symptomatic stage III/IV follicular lymphoma (FL). This includes a systematic review of published evidence and evidence included in the manufacturer's submission (MS).⁶¹

6.1.1 Methods

A systematic search was performed to identify studies addressing the cost-effectiveness of the addition of rituximab to chemotherapy for the first-line treatment of FL. Only full economic evaluations published in English addressing the cost-effectiveness of the addition of rituximab to chemotherapy compared with chemotherapy alone in patients with FL were included in the review.

Eight databases were searched for relevant published literature including MEDLINE, Medline in process (Ovid); CINAHL; EMBASE; NHS EED and HTA databases; Science Citation Index (SCI) and BIOSIS. In addition, literature searches were undertaken for the clinical effectiveness review and quality of life review (see sections 5.1.1), and relevant cost papers were identified from these searches. In addition, the reference lists of relevant articles and the MS⁶¹ were handsearched. Full details of the search strategies used in MEDLINE are presented in Appendix 5 (these have been adapted for use in other databases). Searches were not restricted by language or publication date.

Studies were selected for inclusion through a two-stage process. Titles and abstracts were examined for inclusion by one reviewer. Full manuscripts of selected citations were retrieved and assessed by one reviewer. The quality of the cost-effectiveness studies were assessed using a critical appraisal checklist adapted from the Drummond¹¹⁰ and Eddy¹¹¹ checklists.

6.1.2 Results

Identified studies

The search retrieved 280 citations relating to cost effectiveness (Figure 5). Two hundred and fifty-four articles were excluded at title stage, and 21 articles were excluded at abstract level. Four studies (corresponding to five references) were examined at full-text level^{112,113,114,115,116} and three studies (corresponding to four references) were identified as meeting the inclusion criteria of the systematic review of economic evaluations.^{112,113,114,116} This included the Evidence Review Group (ERG) report submitted to NICE for TA110¹¹³ where the addition of rituximab to CVP in first-line induction treatment was evaluated. Gomez *et al.*¹¹⁵ was excluded from the review as this reference was unobtainable.

Figure 5: Flow diagram of economic evaluation selection/exclusion

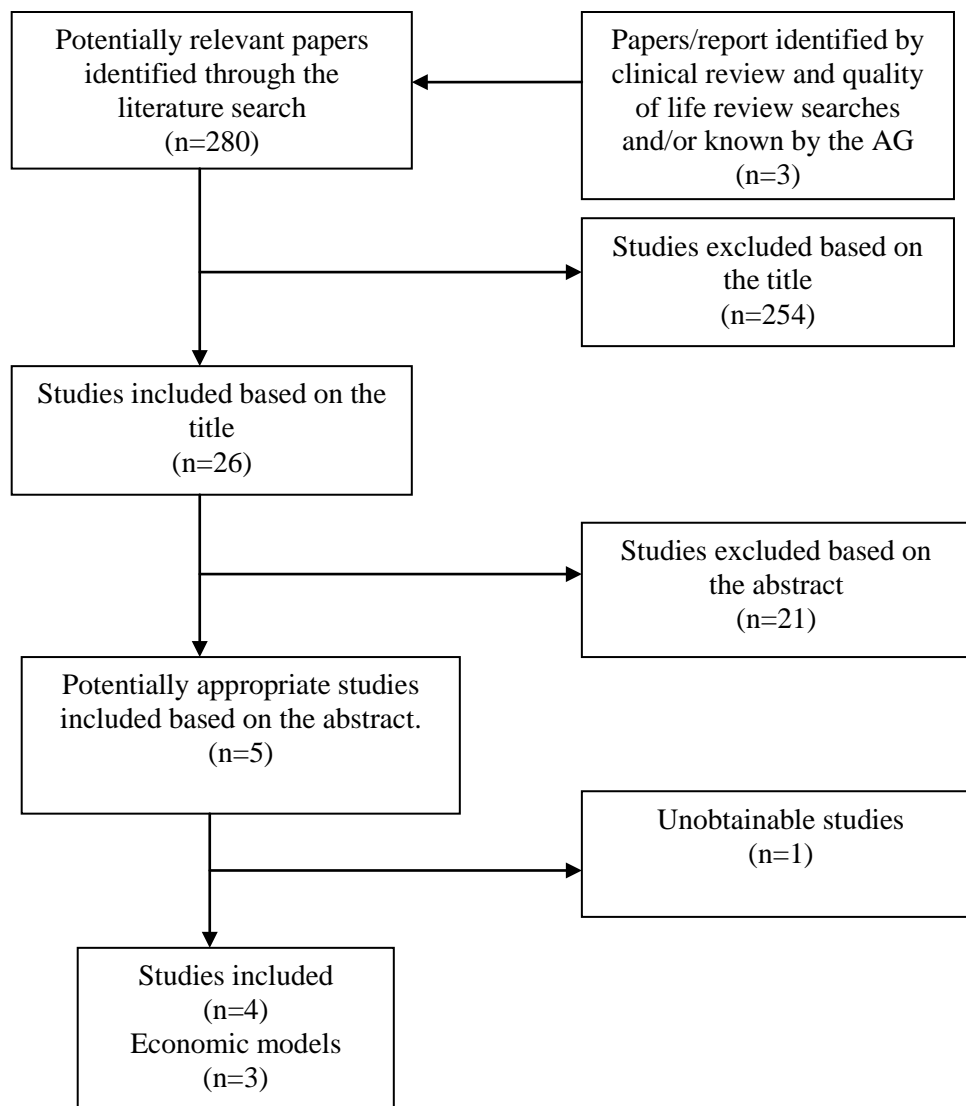

An economic model was described in two studies; an HTA monograph¹¹⁴ and an ERG report.¹¹³ Both studies are based upon a critique undertaken by the ERG of the model submitted by the manufacturer (Roche) for TA 110⁸⁰, a single technology appraisal (STA).

Overall, three different economic models were identified.

Summary of published cost-effectiveness studies

The three identified economic models^{112,113,114,116} were similar and used a Markov approach. There were differences in the comparators used between the studies. Dundar *et al.*^{113,114} and Hornberger *et al.*¹¹⁶ evaluated the cost-effectiveness of the addition of rituximab to CVP only. Ray *et al.*¹¹² reported the cost-effectiveness of the addition of rituximab to a CVP, CHOP, MCP and CHVPi regimen.

Ray *et al.*¹¹² and Dundar *et al.*^{113,114} adopted the perspective of the UK NHS and personal social services (PSS) with costs and benefits discounted at an annual rate of 3.5%. Hornberger *et al.*¹¹⁶ conducted an economic evaluation in the US with costs and benefits discounted at 3.0%.

The impact of main model parameters was examined in univariate sensitivity analyses in all economic evaluations identified by the AG.^{113,114,112,116} Probabilistic sensitivity analyses were performed in the two UK models only.^{113,114,112}

The two UK economic evaluations produced broadly similar incremental cost-effectiveness ratios (ICERs) for the comparison of R-CVP and CVP. Dundar *et al.*^{113,114} reported a cost per QALY gained of £8,290 for the addition of rituximab to a CVP regimen in the MS model. Ray *et al.*¹¹² reported an ICER of £8,613 per QALY gained for the same comparison and reported an ICER of £10,676, £7,455 and £8,498 per QALY gained for the addition of rituximab to a CHOP, MCP and CHVPi regimen respectively. The two UK economic evaluations^{112,113,114} showed that the addition of rituximab to chemotherapy compared with chemotherapy alone has a cost per QALY gained under £20,000.⁹⁶ In the US, Hornberger *et al.*¹¹⁶ reported a cost per QALY gained of \$28,565 for the comparison between R-CVP and CVP.

A tabulated summary of key features and data sources for studies included in the review is presented in Table 27.

Table 27: Tabulated summary of UK cost-effectiveness studies

Parameters	Ray <i>et al.</i> ¹¹²	Dundar <i>et al.</i> ^{113,114} (including ERG report)	Hornberger <i>et al.</i> ¹¹⁶
Comparators	<ul style="list-style-type: none"> • R-CVP vs. CVP • R-CHOP vs. CHOP • R-MCP vs. MCP • R-CHVPi vs. CHVPi 	<ul style="list-style-type: none"> • R-CVP vs. CVP 	<ul style="list-style-type: none"> • R-CVP vs. CVP
Model structure	Markov model with 3 health states: PFS; Progressive disease; death	Markov model with 3 health states: PFS; Progressive disease; death	Markov model with 3 health states: PFS; Progressive disease; death
Age, BSA at baseline	Age: 53 years old BSA (NR): M39021 trial ^{94,95}	Age: 53 years old BSA: NR	Age: 50 years old BSA: 1.72
Time horizon	Lifetime (not specified)	10 years & 25 years	30 years
Sources of effectiveness evidence (first-line induction)	<ul style="list-style-type: none"> • R-CVP vs. CVP^{95,94} • R-CHOP vs. CHOP^{68,90} • R-MCP vs. MCP⁹² • R-CHVPi vs. CHVPi⁹³ 	<ul style="list-style-type: none"> • R-CVP vs. CVP^{95,94} 	<ul style="list-style-type: none"> • R-CVP vs. CVP⁹⁵ (only 40 months) <p>Extrapolation based on observational studies</p>
Sources of effectiveness evidence (Second-line/progression)	<ul style="list-style-type: none"> • Scotland and Newcastle Lymphoma Group¹¹⁷ 	<ul style="list-style-type: none"> • Scotland and Newcastle Lymphoma Group¹¹⁷ 	<ul style="list-style-type: none"> • Observational studies^{28,5,27,118}
Utilities	<ul style="list-style-type: none"> • PFS: 0.805 • PD: 0.618 <p>Source: Oxford outcome study^{119,120}</p>	<ul style="list-style-type: none"> • NR <p>Source: Oxford outcome study^{119,120}</p>	<ul style="list-style-type: none"> • PFS: 0.805 • PD: 0.618 <p>Source: Oxford outcome study^{119,120}</p>
Base-case results (£ /QALY gained)	<ul style="list-style-type: none"> • R-CVP vs. CVP: £8,613 • R-CHOP vs. CHOP: £10,676 • R-MCP vs. MCP: £7,455 • CHVPi vs. CHVPi: £8,498 	<ul style="list-style-type: none"> • R-CVP vs. CVP: £8,290 (MS: 25 yrs) • ERG estimate: £9,015) 	<ul style="list-style-type: none"> • R-CVP vs. CVP: \$28,565

BSA= Body surface area; PD= progressive disease; PFS=progression-free survival; NR = not reported

A full description of each of the three cost-effectiveness studies along with a quality assessment checklist is presented below.

Critical appraisal of economic evaluation

The included cost-effectiveness studies^{113,114,112,116}; were assessed against a critical appraisal checklist adapted from the Drummond¹¹⁰ and Eddy¹¹¹ checklists (Table 28).

Table 28: Critical appraisal checklist of the included economic evaluations

	Ray <i>et al.</i>¹¹²	Dundar <i>et al.</i>^{113,114} (including ERG report)	Hornberger <i>et al.</i>¹¹⁶	
Modelling assessments should include:				
1	A statement of the problem	YES	YES	YES
2	A discussion of the need for modelling vs. alternative methodologies	YES	YES	YES
3	A description of the relevant factors and outcomes;	YES	YES	YES
4	A description of the model including reasons for this type of model and a specification of the scope including; time frame, perspective, comparators and setting. (Note: n=number of health states within sub-model)	YES	YES	YES
5	A description of data sources (including subjective estimates), with a description of the strengths and weaknesses of each source, with reference to a specific classification or hierarchy of evidence;	YES No reference to a hierarchy of evidence	YES No reference to a hierarchy of evidence	YES
6	A list of assumptions pertaining to: the structure of the model (e.g. factors included, relationships, and distributions) and the data.	YES	YES	YES
7	A list of parameter values that will be used for a base case analysis, and a list of the ranges in those values that represent appropriate confidence limits and that will be used in a sensitivity analysis	YES	YES	YES
8	The results derived from applying the model for the base case;	YES	YES	YES

		Ray <i>et al.</i>¹¹²	Dundar <i>et al.</i>^{113,114} (including ERG report)	Hornberger <i>et al.</i>¹¹⁶
Modelling assessments should include:				
9	The results of the sensitivity analyses; unidimensional; best/worst case; multidimensional (Monte Carlo/parametric); threshold.	YES	YES	YES
10	A discussion of how the modelling assumptions might affect the results, indicating both the direction of the bias and the approximate magnitude of the effect;	YES	YES	YES
11	A description of the validation undertaken including; <ul style="list-style-type: none"> • concurrence of experts; • internal consistency; • external consistency; • predictive validity. 	Unclear	YES Model checked by the ERG	Unclear
12	A description of the settings to which the results of the analysis can be applied and a list of factors that could limit the applicability of the results;	Unclear	YES	YES
13	A description of research in progress that could yield new data that could alter the results of the analysis	Unclear	Unclear	Unclear

Description and results of the published economic evaluations

Review of Ray *et al.*¹¹² An evaluation of the cost-effectiveness of rituximab in combination with chemotherapy for the first-line treatment of FL in the UK

Overview

The aim of the study was to estimate the cost-effectiveness of the addition of rituximab to four chemotherapy regimens (CVP, CHOP, MCP, CHVPi) for patients with advanced FL in the UK. The model used a Markov approach and followed patients over a lifetime in three possible health states: PFS; progressive disease and death. The study adopted the perspective of the UK NHS and costs and QALYs were discounted at 3.5%. The mean age of patients entering the model was 53 years old. This study was commissioned by Roche and was available as a full paper.

Summary of effectiveness data

The effectiveness in first-line induction was derived from four randomised phase III clinical trials in patients with FL assessing the addition of rituximab to CVP,^{95,94} CHOP,^{91,90} MCP⁹² and CHVPi.⁹³ Publicly available data were used i.e. from journal manuscripts, as the authors did not have access to individual patient level data for those trials. Ray *et al.*¹¹² estimated the risk of progression by fitting a Weibull and Exponential distributions to the data for the “chemotherapy” arm only. The Exponential distribution was selected for CVP, CHOP and MCP while CHVPi was modelled using a Weibull distribution. The best fit was selected after analyses of the R-square. Ray *et al.*¹¹² also calculated a hazard ratio for the addition of rituximab compared with chemotherapy alone derived from the PFS curves from the paper (through a calculation of the cumulative hazard by summing the negative log of the survival probabilities). These hazard ratios were then applied to the estimated baseline curves to represent the risk of progression for patients receiving rituximab in addition to chemotherapy. The authors assumed that at the end of the PFS period, all patients progressed rather than dying. The rate of mortality whilst in PFS was assumed to be that reported in UK life tables.

After relapse following first-line induction treatment, patients entered a “progressive” health state (including subsequent relapses and lines of treatment) with patients remaining in this health state until death. The rate of progression from the “progressive” health state to death was calculated using registry data from the Scotland and Newcastle Lymphoma Group (SNLG) assuming an Exponential distribution. Deaths from other causes were included using the rates reported in UK life tables.

Utility values were estimated using the Euroqol (EQ)-5D and were extracted from the Oxford Outcome Study^{119,120} which was conducted in a cohort of 222 patients with FL in the UK. Patients in PFS were assumed to have a utility value of 0.805 while patients in the progressive health state had a utility value of 0.618.

Adverse events were not included in the base case analysis. However, a scenario analysis was conducted to estimate the impact of including additional costs associated with treating adverse events and infusion site reactions on the cost-effectiveness of rituximab added to chemotherapy.

Summary of resource utilisation and cost data

Drug costs were taken from the Monthly Index of Medical Specialities (MIMS) using the mean doses administered in the trials^{94,95,90,91,92} (except for CHVPi). Administration costs were taken from the NHS reference costs and transformed into a monthly cost (£309 per month for chemotherapy alone and £430 per month for R-chemotherapy). Drug costs for patients in the “progressive” health state were derived from the published literature and assumptions (£195 per month).^{80,121}

The model also incorporated the cost of routine management for patients in PFS (one outpatient visit every 3 months) and in the progressive health state (one outpatient visit every month – £103). The cost of adverse events was not included in the base case.

Summary of cost-effectiveness

In the base case analysis (table 29), the addition of rituximab to CVP, CHOP, MCP and CHVPi led to a gain of 0.914, 0.831, 1.184 and 0.458 discounted QALYs respectively compared with chemotherapy alone.¹¹² The incremental discounted cost of the addition of rituximab to chemotherapy was estimated to be £7,878, £8,872, £8,826 and £3,892 respectively.

The ICER associated with the addition of rituximab to CVP, CHOP, MCP and CHVPi compared with chemotherapy alone was estimated to be £8,613, £10,676, £7,455 and £8,498 per QALY gained respectively.

Table 29: Tabulated summary of the cost-effectiveness of the addition of rituximab to chemotherapy compared with chemotherapy alone (Adapted from Table 4 in Ray *et al.*)¹¹²

	LY	QALY	Cost	£/QALY gained
CVP	6.710	4.748	£20,708	
R-CVP	7.764	5.392	£28,582	£8,613
CHOP	7.887	5.504	£20,922	
R-CHOP	8.842	6.335	£29,794	£10,676
MCP	7.954	5.563	£20,900	
R-MCP	9.312	6.747	£29,725	£7,455
CHVPi	7.900	5.508	£29,621	
R-CHVPi	8.428	5.966	£33,513	£8,498

One way sensitivity analyses showed that the results were most sensitive to the time horizon and whether the treatment effect extended beyond the trial period. Probabilistic sensitivity analyses were also conducted. The uncertainty regarding the estimates of costs and QALYs were expressed using cost-effectiveness acceptability curves (CEAC) and cost-effectiveness frontiers. There was a high probability that the addition of rituximab to chemotherapy has a cost per QALY gained below £20,000.

Ray *et al.*¹¹² also conducted incremental analysis comparing across chemotherapy regimens. The authors reported that MCP was cost-effective compared with CVP alone (£235 per QALY gained). CHOP, CHVPi and R-CVP were dominated by MCP as those regimens provided lower QALYs at a higher cost. Similarly, R-CHOP and R-CHVPi were dominated by R-MCP. This analysis assumed that the treatment effect extended over a lifetime. Ray *et al.*¹¹² also presented an additional scenario by restricting the treatment effect of the addition of rituximab to 53 months. Overall, the authors found that MCP dominated R-CVP and CHOP. R-MCP dominated R-CHVPi and CHVPi. R-CHOP was extendly dominated by R-MCP.

Comments

It was not possible for the AG to check the economic model as only the publication was available in the public domain. Based on the description of the model, this appears to be a reasonably well conducted cost-effectiveness analysis. The generalisability of results from this study are however limited. The baseline age of the modelled cohort is not representative of FL

patients in first-line treatment in the UK (younger). Furthermore, the authors only explored the use of Exponential or Weibull distributions to represent the rate of progression in patients treated in first-line induction. Alternative distributions might provide a better fit to the data. Similarly, the rate of progression in second-line was modelled using an Exponential distribution and no goodness of fit statistics were provided.

An important limitation is the source of effectiveness used for patients treated in first-line induction with CHOP, MCP and CHVPi with or without rituximab. Responders to first-line induction with CHOP with or without rituximab were randomised to maintenance with interferon or SCT.^{90,91} Responders to MCP with or without rituximab received maintenance interferon.⁹² Similarly, the effectiveness for patients treated with CHVPi in first-line with or without rituximab is confounded by the introduction of interferon during induction and the differences in treatment received post-induction.⁹³ This is likely to over-estimate the absolute gain in life years/QALYs associated with the addition of rituximab to chemotherapy. The model also did not consider that at the end of the PFS period, the outcome could be death rather than progression.

Some assumptions were also made by the authors and were not discussed. Patients were assumed to receive the same treatment post-progression, irrespective of the choice of first-line treatment. Similarly, the source of effectiveness used to represent the rate of progression after relapse did not incorporate changes in the treatment pathways in the UK for relapsed patients (use of R-chemotherapy in combination with maintenance rituximab). It was also unclear from the study if patients were previously treated with rituximab or the type of chemotherapy received in first-line induction.

Finally, Ray *et al.*¹¹² conducted incremental analyses comparing across chemotherapy regimens. After discussion with clinical experts, the AG disagrees with this approach as the choice of chemotherapy is also based on patients' characteristics and not solely the effectiveness of the chemotherapy (see section 6.4.1 for further discussion).

Review of Dundar *et al.*^{113,114} Rituximab for the first-line treatment of stage III-IV FL

Two studies were available; an HTA monograph¹¹⁴ and the ERG report.¹¹³ Both studies are based upon a critique undertaken by the ERG of the model submitted by the manufacturer (Roche) in TA 110⁸⁰, a single technology appraisal (STA).

There is no published work with a first-hand description of the model. Our review is based on the ERG report¹¹³ for TA110⁸⁰ as this provided more detailed description on the economic evaluation submitted by the manufacturer. The submission made by the manufacturer was not publicly available.

Overview

The aim of the study was to evaluate the MS that estimated the cost-effectiveness of the addition of rituximab to CVP for first-line treatment of patients with advanced FL in the UK. The economic evaluation submitted by the manufacturer shared several features with the model published by Ray *et al.*¹¹² The model used a Markov approach and followed patients over 25 years in three possible health states: PFS; progressive disease and death. The study also adopted the perspective of the UK NHS, with costs and QALYs discounted at 3.5%. The mean age of patients entering the model was 53 years old.

Summary of effectiveness data

The effectiveness in first-line induction was derived from a randomised phase III clinical trial in patients with FL assessing the addition of rituximab to CVP.^{94,95} Log-logistic distributions were fitted to individual patient-level data from the trial to represent the risk of progression after first-line induction treatment. Adverse events were omitted.

After relapse following first-line induction, patients entered a “progressive” health state (which included subsequent relapses and lines of treatment) with patients remaining in this health state until death. The rate of progression from the “progressive” health state to death was calculated using registry data from the SNLG assuming an Exponential distribution. Deaths from other causes were included using UK life tables.

Utility values were estimated using the EQ-5D and were extracted from the Oxford Outcome Study.^{119,120} The utility values used for the PFS and “progressive” health states were marked as commercial in confidence.

Summary of resource utilisation and cost data

Patients were assumed to receive 8 cycles of treatments (assigned to the first cycle in the model). The surveillance costs in PFS were calculated to be £32.33 per month assuming four annual oncology visits.¹¹³ Drug costs for patients in the progressive health state were derived from the published literature and assumptions and were assumed to be £193.33 per month.¹²¹

Summary of cost-effectiveness

In the base case analysis, the addition of rituximab to CVP led to a gain of 1.251 discounted QALYs compared with chemotherapy alone. The incremental discounted cost of the addition of rituximab to chemotherapy alone was estimated to be £10,370. The ICER associated with the addition of rituximab to CVP compared with chemotherapy alone was estimated to be £8,290 per QALY gained.

One way sensitivity analyses showed that the results were most sensitive to the time horizon and treatment length and whether the treatment effect extended beyond the trial. Probabilistic sensitivity analyses were conducted and indicated that at a threshold of £30,000 per QALY gained, there was 100% probability that R-CVP was cost-effective compared with CVP.

The ERG corrected errors identified in the MS and made some modifications to the economic model (translation of gain in PFS into OS and use of a Weibull distribution to represent the risk of progression in the “progressive” health state). The ICER estimated by the ERG was £9,015 per QALY gained (with 64% of PFS translating into OS). If no OS gain was assumed, the ICER increased to £20,593 per QALY gained.

Comments made by the ERG

As the report¹¹³ is based on a previous review of the economic model submitted by the manufacturer, the AG did not perform an independent assessment of this economic evaluation due to resource constraints and the availability of a previous critic of the model (i.e. the ERG assessment).

The ERG identified mistakes/inconsistencies after reviewing the economic model. More details are available in the ERG report.¹¹³ In addition to the errors, the ERG highlighted some limitations in the manufacturer’s model:

- the manufacturer assumed that most of the gain in PFS translated into a gain in OS (79% according to the ERG).
- the baseline age was not representative of the patients in the UK receiving first-line therapy.

- utility values used; the manufacturer did not age-adjust utility values, and utilities were calculated from a small sample size (especially for the “progressive” health state).
- the progression rate for patients in the “progressive” health state. The ERG indicated that the Exponential distribution selected by the manufacturer did not provide a good fit to the data and that a Weibull distribution would provide a more reasonable fit. Furthermore, the ERG questioned data from the SLNG in the absence of details about the characteristics of included patients.
- the cost in the “progressive” health state included the cost of first-line therapy, and therefore inflated the cost for patients remaining longer in the “progressive” health state.

Review of Hornberger *et al.*¹¹⁶ Economic evaluation of rituximab and CVP for advanced FL

Overview

The aim of the study was to assess the cost-effectiveness of R-CVP versus CVP in the US. The economic evaluation shared several features with the model assessed by the ERG in TA 110^{114,113,80} and Ray *et al.*¹¹² The model used a Markov approach and followed patients over 30 years in three possible health states: PFS; progressive disease and death. The study adopted a societal perspective with costs and QALYs discounted at 3.0%. The mean age of patients entering the model was 50 years old.

Summary of effectiveness data

The effectiveness in first-line induction was derived from a randomised phase III clinical trial in patients with FL assessing the addition of rituximab to CVP.⁹⁵ The PFS and OS Kaplan Meier (KM) from the M39021 trial^{94,95} was used for the first 4 years and extrapolated beyond the trial based on published findings of long term observational study.^{5,27,28,118} An annual mortality rate of 6.9% was applied.

The utility values for the time spent in each health state was extracted from the Oxford outcome study.^{119,120} The utility values for patients in progression-free and progression health state were 0.805 and 0.618 respectively. The economic model also incorporated the disutility associated with chemotherapy (-0.15), stem cell transplantation (-0.20) and end of life (-0.30).¹²² There is no indication on how long the disutility was assumed to be.

Summary of resource utilisation and cost data

Unit drug costs were derived from Medicare J-codes using the Mosby 2006 drug costs. The model assumed a body surface area of 1.72 m² and drug wastage was considered. Administration costs were derived from the number of hours of infusions and the cost per hour of administration from

the current procedural terminology (CPT).¹²³ The models incorporated grade 3 and 4 adverse events that had at least a 2% rate difference between the two arms. The cost of subsequent treatment regimens was derived from the cost of most common regimens recommended by the National Comprehensive Cancer Network (NCCN). Maintenance after second-line induction for responders to chemotherapy was considered in the analysis.

Subsequent treatments had no impact on OS and were only included for costing purpose. Subsequent treatments were applied at the median time to progression and one year thereafter. Salvage therapy was also included and it was assumed that 10% of patients undergo SCT as part of subsequent therapy. Finally, the economic evaluation included the cost of end of life.¹²⁴

Summary of cost-effectiveness

In the base case analysis, the addition of rituximab to CVP led to a gain of 0.93 discounted QALYs compared with chemotherapy alone. The incremental discounted cost of the addition of rituximab to chemotherapy alone was estimated to be \$26,439. The ICER associated with the addition of rituximab to CVP compared with chemotherapy alone was estimated to be \$28,565 per QALY gained.

One way sensitivity analyses showed that the results were most sensitive to utility values and the cost for a course of rituximab. Hornberger *et al.*¹¹⁶ reported that none of the sensitivity analyses generated a cost per QALY gained greater than \$50,000 per QALY gained.

Comments

It was not possible for the AG to check the economic model as only the publication was available in the public domain. Based on the description of the model, this appears to be a reasonably well conducted cost-effectiveness analysis.¹¹⁶ The generalisability of results from this study may however be limited as the study was conducted in the US. Furthermore, the baseline age of the modelled cohort (50 years old) was not representative of FL patients in first-line treatment in the UK. Hornberger *et al.*¹¹⁶ provided a very detailed description of the derivation of costs. However, the description of clinical effectiveness was poor. It is unclear how the PFS and OS KM were extrapolated after 4 years.

6.2 Assessment of the manufacturer's submission

There was one industry submission to NICE from Roche.⁶¹ The MS included a full report and an electronic model submitted in MS Excel[®]. The economic model submitted by the manufacturer was reviewed to check that the parameters presented in the report corresponded to those used in the economic model. The economic model included in the MS was assessed using a critical appraisal checklist adapted from the Drummond and Jefferson¹¹⁰ and Eddy¹¹¹ checklists (Table 30).

Table 30: Critical appraisal checklist of the economic model included in the MS⁶¹

		MS ⁶¹
Modelling assessments should include:		
1	A statement of the problem;	YES
2	A discussion of the need for modelling vs. alternative methodologies	YES
3	A description of the relevant factors and outcomes;	YES
4	A description of the model including reasons for this type of model and a specification of the scope including; time frame, perspective, comparators and setting. Note: n=number of health states within sub-model	YES
5	A description of data sources (including subjective estimates), with a description of the strengths and weaknesses of each source, with reference to a specific classification or hierarchy of evidence;	YES
6	A list of assumptions pertaining to: the structure of the model (e.g. factors included, relationships, and distributions) and the data;	YES
7	A list of parameter values that will be used for a base case analysis, and a list of the ranges in those values that represent appropriate confidence limits and that will be used in a sensitivity analysis;	YES
8	The results derived from applying the model for the base case;	YES
9	The results of the sensitivity analyses; unidimensional; best/worst case; multidimensional (Monte Carlo/parametric); threshold.	YES

		MS ⁶¹
Modelling assessments should include:		
10	A discussion of how the modelling assumptions might affect the results, indicating both the direction of the bias and the approximate magnitude of the effect;	YES
11	A description of the validation undertaken including; <ul style="list-style-type: none"> • concurrence of experts; • internal consistency; • external consistency; • predictive validity. 	Unclear
12	A description of the settings to which the results of the analysis can be applied and a list of factors that could limit the applicability of the results;	Unclear
13	A description of research in progress that could yield new data that could alter the results of the analysis	Unclear

6.2.1 Description of the manufacturer's submission

Overview

The MS⁶¹ used a state-transition model with individuals moving between four possible health states: progression-free survival/first-line induction treatment (PFS1); progression-free survival/second-line treatment (PFS2); progressive disease (PD) and death (Figure 6). The model compared the cost-effectiveness of the addition of rituximab to CVP, CHOP, MCP and CHVPi for patients with advanced FL in the UK. The starting age in the model was 60 years and patients were followed up for 25 years. The study adopted the perspective of the UK NHS, with costs and QALYs discounted at 3.5%. A tabulated summary of key features and data sources of the economic model included in the MS is presented in Table 31.

Figure 6: Model structure included in the MS⁶¹ (reproduction of Figure 3, p.104 in the MS)

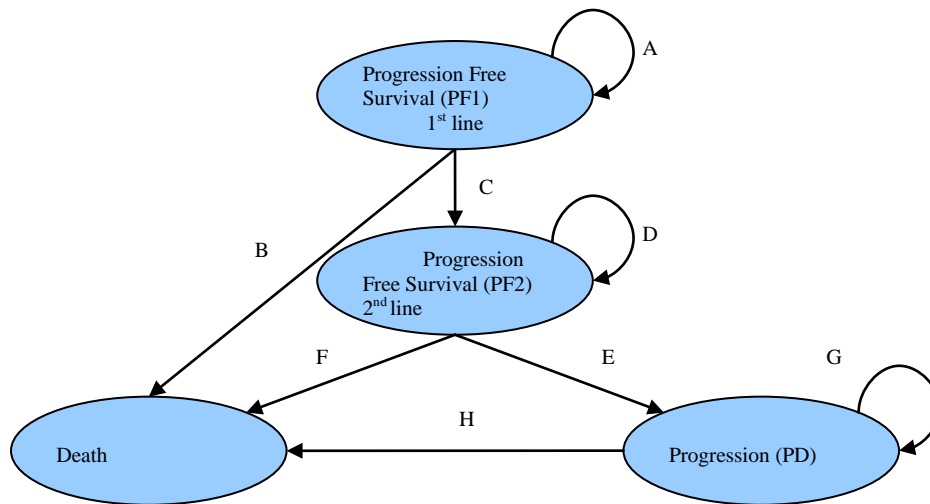

Table 31: Tabulated summary of the economic model included in the MS⁶¹

Parameters	MS⁶¹
Comparators	<ul style="list-style-type: none"> • R-CVP vs. CVP • R-CHOP vs. CHOP • R-MCP vs. MCP • R-CHVPi vs. CHVPi
Model structure	State transition approach with 4 health states; PFS1, PFS2, PD, death
Age, BSA at baseline	Age: 60 years old ; BSA: 1.8528 m ²
Time horizon	25 years
Sources of effectiveness evidence (first-line induction)	<ul style="list-style-type: none"> • R-CVP vs. CVP^{94,95} • R-CHOP vs. CHOP^{90,91} • R-MCP vs. MCP⁹² • R-CHVPi vs. CHVPi⁹³ Parametric extrapolation (Log-logistic, Weibull, Exponential)
Sources of effectiveness evidence (Second-line/progression)	<ul style="list-style-type: none"> • EORTC 20981 trial^{71,72}; Inclusion of 2nd line maintenance Parametric extrapolation (Exponential)
Utilities	<ul style="list-style-type: none"> • PFS1:0.88 • PFS2:0.79 • PD: 0.62 Source: Oxford outcome study ^{119,120}
Base-case results (£ /QALY gained)	<ul style="list-style-type: none"> • R-CVP vs. CVP: £1,529 - £5,611 • R-CHOP vs. CHOP: 5,758 • R-MCP vs. MCP: £4,861 • R-CHVPi vs. CHVPi: £9,251

Summary of effectiveness data

The effectiveness in first-line induction treatment was derived from four randomised phase III clinical trials in patients with FL comparing the addition of rituximab to CVP,^{94,95} CHOP,^{90,91} MCP⁹² and CHVPi.⁹³ Individual patient level data from the M39021 trial^{95,94,61} were used to estimate the rate of progression among patients treated with CVP or R-CVP in first-line induction assuming a log-logistic distribution. Individual patient level data for the trials that compared CHOP versus R-CHOP, MCP versus R-MCP and CHVPi versus R-CHVPi^{90,91,92,93} were not available to the manufacturer and therefore only publicly available data were used. A similar methodology to Ray *et al.*¹¹² was used by fitting a Weibull or Exponential distribution (to the digitised data from the papers) to patients treated in first-line with chemotherapy alone. The Exponential distribution was selected for CHOP and MCP while the Weibull distribution was chosen for CHVPi based on the R-square. A hazard ratio was then applied to the estimated curves for the first 53 months to estimate the reduction in the risk of progression for patients receiving rituximab in addition to chemotherapy. Deaths in PFS1 were derived from the number of deaths and follow-up duration from the M39021 trial.^{94,95}

The effectiveness in PFS2/second-line treatment was based on data from the EORTC 20981 trial^{71,72} conducted among patients treated with CHOP or R-CHOP with or without maintenance rituximab in second-line. Digitised data from the paper^{71,72} were used in the absence of individual patient level data. The manufacturer used Exponential distributions to estimate the risk of progression. The manufacturer stated that *“In order to avoid overcomplicating the model, the transition probabilities of progressing from PFS2 were not varied over time. Varying the probabilities over time would require tracking patients’ progression within the model and would result in an Exponential increase of the size and complexity of the model with limited impact to the cost effectiveness of rituximab in first-line”*. The most up-to-date data from the EORTC 20981 trial⁷¹ were used to estimate the progression rate from PFS2 to the progressive health state, and from the progressive health state to death (Post-progression-Survival – PPS). The PPS have been calculated as a function of PFS and OS assuming that the rate of progression in PPS equalled the sum of the rate of progression in OS and PFS. The manufacturer also attempted to apply a rule so that patients treated with rituximab in first-line induction and who relapse within 6-12 months would not receive rituximab in second-line induction.

Utilities were extracted from a study commissioned by the manufacturer (Oxford Outcomes study).^{119,120} The following utility values were used in the economic model; PFS1 = 0.88 (disease free); PFS2 = 0.79 (remission/full response); progressive disease = 0.62. Adverse events were not included in the MS.

Summary of resource utilisation and cost data

Drug costs were taken from the BNF⁸⁴ using the planned dose from the trials. Administration costs were taken from NHS reference costs. The manufacturer also assumed that rituximab treatment was administered as a hospital day case.

The cost associated with monitoring/surveillance after induction treatment was derived from a study commissioned by the manufacturer. Supportive care costs for patients in the progressive health state (£500.53 per month) was derived from the cost used in the MS for an ongoing NICE appraisal¹²⁵ from the post-protocol treatment from the EORTC 20891 trial^{71,72} and the cost of palliative care in the UK.¹²⁶

Summary of cost-effectiveness

Two analyses were presented for R-CVP versus CVP. The first analysis fitted separate curves to each arm using individual patient level data, whereas the second analysis assumed a hazard ratio (for R-CVP) for the first 53 months and fitted a parametric curve to CVP using the same approach as for CHOP, MCP and CHVPi.

In the base case analysis, the addition of rituximab to CVP, CHOP, MCP and CHVPi led to a gain of 0.867 / 0.443, 1.096, 1.289 and 0.675 discounted QALYs compared with chemotherapy alone. The incremental discounted cost of the addition of rituximab to chemotherapy was estimated to be £1,325 / £2,486, £6,312, £6,268 and £6,247 respectively. Thus, the addition of rituximab to CVP, CHOP, MCP and CHVPi compared with chemotherapy alone resulted in an ICER of £1,529 / £5,611, £5,758, £4,861 and £9,251 per QALY gained respectively.

One way sensitivity analyses showed that the results were robust to parameter changes with none of the sensitivity analyses increasing the ICER above £20,000 per QALY gained. Probabilistic sensitivity analyses (PSA) were conducted. The PSA results indicated that the addition of rituximab to chemotherapy compared with chemotherapy alone was highly cost-effective assuming a WTP threshold of £20,000 per QALY gained. No incremental analysis was presented to compare across chemotherapy regimens.

Table 32: Summary of the cost-effectiveness of the addition of rituximab to chemotherapy compared with chemotherapy alone included in the MS⁶¹

	LY	QALY	Cost	£/QALY gained
CVP	7.618	5.828	£43,061	
R-CVP	8.386	6.695	£44,386	£1,529^a
CVP	7.342	5.544	£44,570	
R-CVP	7.668	5.987	£47,056	£5,611^b
CHOP	8.279	6.479	£42,717	
R-CHOP	9.407	7.575	£49,029	£5,758
MCP	8.332	6.532	£42,072	
R-MCP	9.671	7.821	£48,340	£4,861
CHVPi	8.297	6.487	£47,885	
R-CHVPi	9.039	7.162	£54,132	£9,251

^a Using individual patient level data; ^b Same approach as for CHOP, MCP and CHVPi

6.2.2 Critique of the manufacturer's submission

The AG reviewed the economic model and report included in the MS.⁶¹ A detailed critique is presented below. In summary, there are concerns with the MS analyses.⁶¹ Errors and inconsistencies were identified in the economic model. The model had also limitations relating to the source of effectiveness for patients treated in first- or second-line. For readability, we critique each section in turn.

Review of previous analyses and Quality of life data.

No economic review or quality of life reviews were included in the MS.

Sources of effectiveness for CHOP, MCP and CHVPi with or without rituximab

The trials used^{90,91,92,93} were likely to over-estimate the effect of rituximab given that responders to first-line induction treatment received subsequent treatments with interferon maintenance or SCT (see section 5.2.2). This issue was not discussed in the MS.⁶¹

Method used to estimate the rate of progression in the absence of patient level data

Due to the lack of individual patient level data, the manufacturer assumed that the time to progression was represented by either a Weibull or an Exponential distribution, with these distributions estimated using ordinary least squares regression method. This approach is commonly used in health economic models when only data from manuscripts are available. However, it appears that there a number of errors and inconsistencies in the process used by the manufacturer to estimate the Exponential distribution. By definition, the Exponential distribution is composed of only one parameter (λ) as the rate is constant and does not vary with time. However, the manufacturer fitted a linear regression model ($y = \alpha * t + \lambda$) to the transformed data (log scale) that contained 2 parameters; λ (constant) and α (variable time dependent). In some parts of the economic model, the rate of progression was calculated using λ only or the sum of λ and α . The inconsistency in the approach used limits the interpretation of the estimated coefficients used throughout the economic model. Furthermore, this approach is not correct as this sometimes includes or excludes a time-dependent variable. The linear model has to be of the following form in order to estimate the parameter of the Exponential distribution; $y = \alpha * t$.

Inconsistencies and errors were identified between the risk of progression presented in the report and the risk of progression used in the economic model, notably in second-line. In most cases, the fitted Exponential distribution (using an ordinary least square methodology) was not found to provide a reasonable fit to the data. Therefore, it appears that the manufacturer adjusted the parameters of the Exponential distribution “manually” by adding extra parameters in order to provide a reasonable visual fit to the data. This was not discussed by the manufacturer in the

report and was identified by the AG only after review of the economic model. In some instances, the unadjusted coefficients were used (instead of the coefficient artificially adjusted to fit the data) in the economic model. For example, considering the PFS for patients treated with R-CHOP as induction in second-line and maintenance with rituximab (Figure 7). The curve presented by the manufacturer in the report (grey line) was estimated after the addition of extra parameters (manual adjustment). However, in the economic model the dashed grey curve (before adjustment) was used (estimated by the AG), which provided a poorer fit.

Figure 7: KM plot and Exponential distributions presented in the MS⁶¹ and used in the economic model for patients that respond to R-CHOP second-line induction treatment and receive maintenance rituximab.

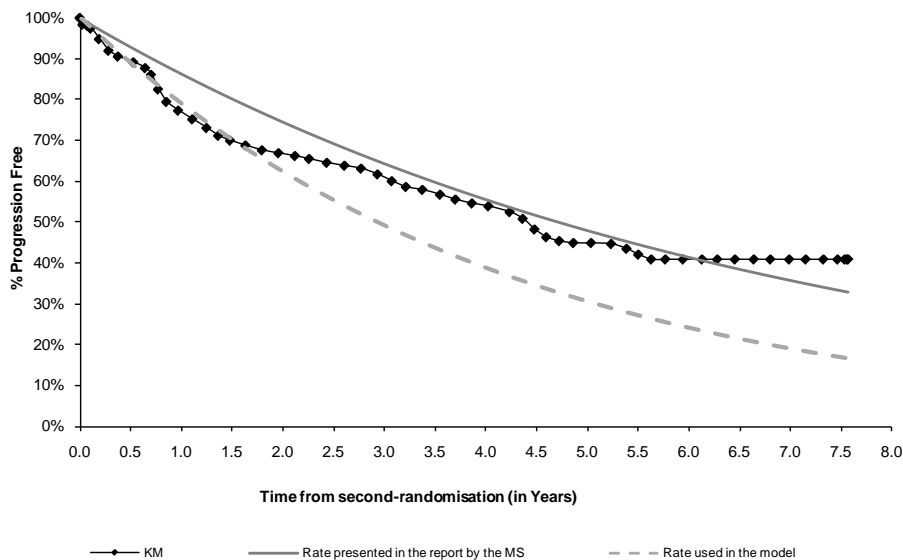

Approach used to estimate the hazard ratio

The hazard ratios were calculated by taking the cumulative hazard (estimated by the sum of the negative log of the survival) from the PFS KM curve estimated from the appropriate trials. The AG acknowledges that the approach was necessary in the absence of individual patient level data. However, the AG note that such an approach might introduce bias as the calculated cumulative hazard is dependent on the number of point estimates considered. A better approach would be to estimate the hazard ratio from the baseline parametric survival curve.

Duration of benefits

The manufacturer assumed that the treatment effect (hazard ratio) lasts 53 months based on the median follow-up duration in the M39021 trial.^{94,95} However, the follow-up was different in other trials used.^{90,91,92,93}

Rule for patients previously treated with rituximab

The manufacturer wished to apply a rule whereby patients that relapsed within 6-12 months after first-line induction treatment with rituximab would not be eligible for rituximab in second-line treatment if previously exposed to rituximab. However, the decision of the manufacturer to simplify the economic model structure meant that several assumptions had to be made as the model was not able to track patients over time.

Treatment pathway

The manufacturer assumed that patients can only receive CHOP or R-CHOP in second-line (followed or not by maintenance rituximab). Discussion with clinical experts indicated that CHOP containing regimens are aggressive and therefore mainly used in younger patients. Older patients are likely to receive less aggressive chemotherapy regimens such as fludarabine and cyclophosphamide (FC) with or without rituximab. Furthermore, clinical experts indicated that anthracycline containing regimens (CHOP, MCP, CHVP) should only be used once in a lifetime and therefore patients previously treated with anthracycline regimens are likely to receive SCT in second-line if fit enough or less aggressive chemotherapies (FC) if not considered sufficiently fit.

Source of effectiveness for patients treated in second-line

The manufacturer used data from the EORTC 20981 trial^{72,71} to estimate the risk of progression for patients treated with CHOP or R-CHOP in second-line with or without maintenance. However, patients in this study were rituximab-naïve, i.e. not previously treated with rituximab. The applicability of outcomes from this study to patients previously treated with rituximab is unclear. Furthermore, because data from second randomisation (i.e. after response induction) were used, the time spent in second-line induction (where the risk is zero for responders) was missing from calculations of PFS and OS. Furthermore, outcomes for non-responders were missed.

Estimation of Post-progression survival (PPS)

The manufacturer estimated PPS as a function of PFS and OS from the EORTC 20981 trial.^{72,71} The AG, however, has some concerns about the approach used by the manufacturer. The manufacturer calculated PPS as the additive risk of OS and PFS (using the coefficients of the Exponential distribution) so that $PPS = OS + PFS$. It is unclear why the addition of the coefficient of PFS and OS would be equal to the coefficient of PPS. Furthermore, the manufacturer used direct coefficients of the Exponential distribution to estimate PPS before their “manual adjustment” (curves are artificially modified to fit the data). This means that the curves for OS and PFS used to calculate PPS no longer fitted the data (Figure 8 and 9). Finally, the manufacturer used the combined data for patients randomised to observation or maintenance, therefore implying that the PPS would be the same following CHOP or R-CHOP induction.

Figure 8: KM plot and Exponential distribution used to calculate PPS reported in the MS⁶¹ and actually used in the economic model for patients receiving observation after response to second-line induction treatment

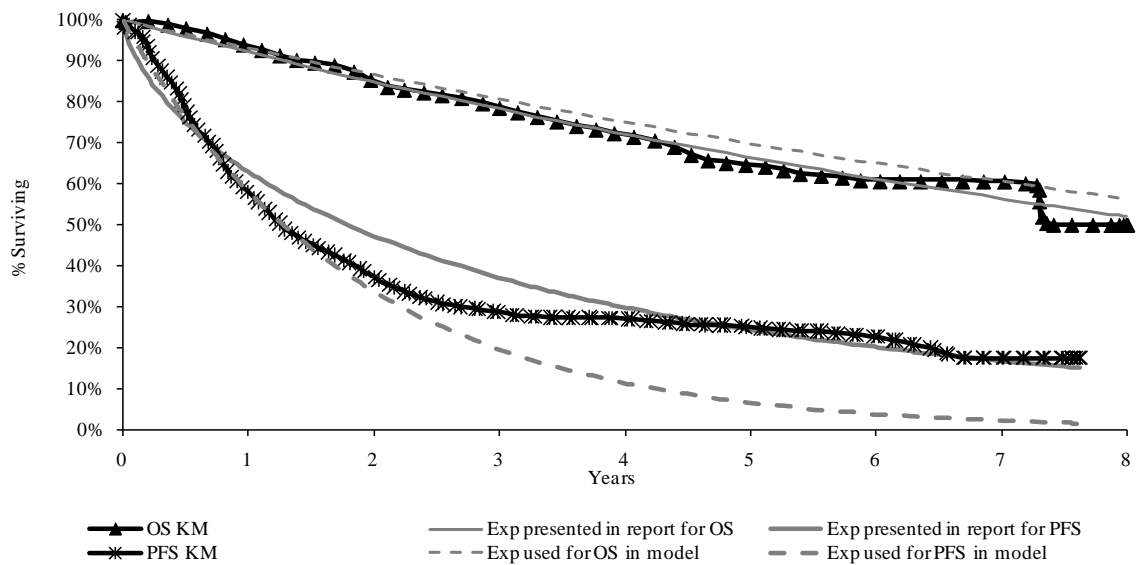

Exp = Exponential distribution

Figure 9: KM plot and Exponential distribution used to calculate PPS reported in the MS⁶¹ and actually used in the economic model for patients receiving maintenance rituximab after response to second-line induction treatment

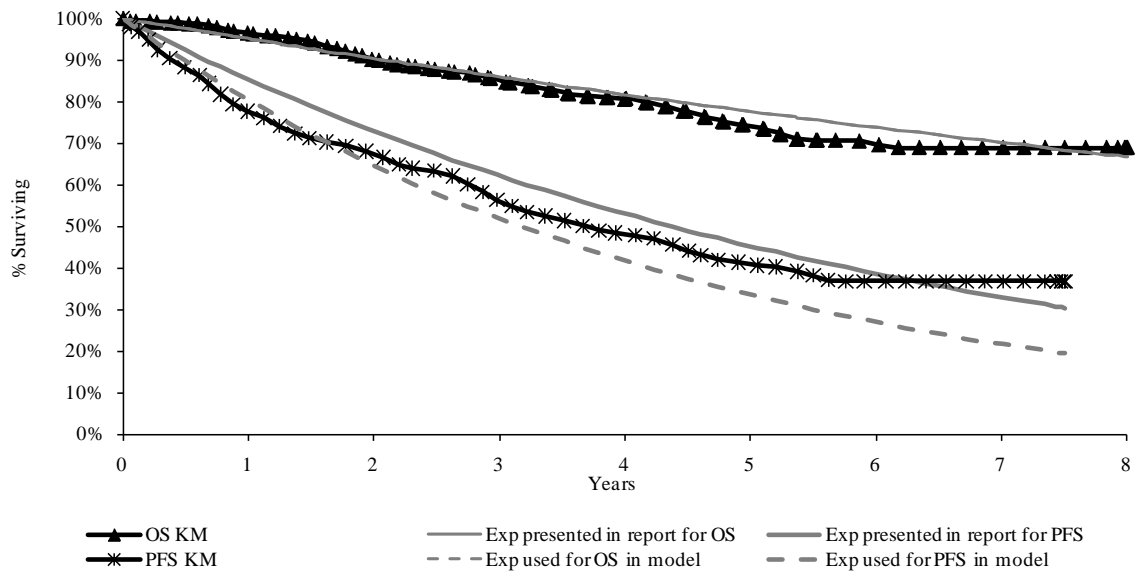

Exp = Exponential distribution

Model structure

Whilst Markov models are commonly used for oncology treatments, the Markov approach requires assumptions and can be inflexible. The manufacturer used Exponential distributions to “avoid over-complicating” the model. However, in most cases, the Exponential distribution did not fit the data well.

Adverse events

The MS⁶¹ did not include the impact of adverse events either in terms of costs or impact on quality of life stating that there is no clinically significant difference between the rates and/or severity of adverse events observed in the rituximab arms of each of the four first-line clinical trials^{94,95,90,91,92,93} when compared with the respective comparator arms. However, the clinical effectiveness review indicated that a greater number of blood and bone marrow adverse events occurred in the R-chemotherapy than chemotherapy alone arm, for e.g. neutropenia, leukocytopenia. Despite these adverse events not resulting in a difference in infection rates and thus being clinically significant, they would still incur costs to treat and their exclusion might bias the cost-effectiveness in favour of rituximab.

Treatment/management costs

Several errors/inconsistencies were identified by the AG after review of the economic model. First, the planned number of cycles in the EORTC 20981 trial^{71,72} (used to represent second-line treatment) is 6 cycles of CHOP or R-CHOP. Assuming a cost per cycle of £1,462 for R-CHOP (estimated by the manufacturer), the maximum cost that a patient can incur is £8,772 (£1,462 * 6). In the economic model, the cost for patients treated with R-CHOP (accounting for the fact that some patients receive less than the planned dose due to progression) was estimated to be £11,305 by the MS. This is due to an error in the translation between month and cycle. The same error was found for the calculation of the cost of administration in second-line.

The MS⁶¹ also used a complicated formula to estimate the cost associated with maintenance based on the area under the curve from the most up-to-date EORTC 20981 trial data.⁷¹ The cost was then applied to the first cycle in the economic model. The AG had some difficulty in following the logic, however, we believe that costs were discounted twice.

Inconsistencies were also identified in the approach used to estimate the management costs in the “progressive” health state. The manufacturer calculated a cost per month including the cost associated with the post-protocol treatment from the EORTC 20981 trial^{71,72} and the cost of palliative care.¹²⁶ This had the effect of inflating the cost for patients who spend a longer time in the “progressive” health state and bias the cost-effectiveness in favour of rituximab.

The manufacturer also assumed no drug wastage. This might not be true if chemotherapies are not given in a large centre and vial sharing is not possible.

Utilities

The economic model included in the MS⁶¹ used utility values from the Oxford Outcomes study.^{119,120} The manufacturer assumed that the utility in PFS1 was similar to the utility of patients considered to be disease free (0.88; CI: 0.81- 0.95). The utility for patients in remission/full response to therapy (0.79; CI: 0.72 – 0.86) was used to represent the utility for patients in PFS2. Finally, the utility for progressive disease was assumed to be 0.62 (CI: 0.48 – 0.76). As suggested by the ERG in the ongoing appraisal for first-line maintenance,^{127,128} it seems inappropriate to assume that patients in PFS1 and PFS2 have different utility values given that these patients are in remission. This choice by the manufacturer to use the utility for patients considered to be “disease-free” to represent the utility in patients in PFS1 also appears to be inappropriate as these patients are in a “remission” state and not “disease-free”.

Other assumptions

The MS⁶¹ assumed that there were no resistance effects among patients previously treated with rituximab implying that the efficacy would be equal regardless of previous treatment. The MS⁶¹ referred to two studies to support the assumption of the absence of a resistance effect to rituximab.^{129,130} However, the AG does not believe that the data from these two studies provide conclusive evidence that the resistance of rituximab is not a consideration. Further studies identified by the AG in other types of lymphoma^{131,132,133} suggest that there might be a resistance effect to rituximab. Further discussion on resistance is in section 6.4.1 (p.146).

6.3 Relevance of cost-effectiveness evidence for NICE decision making

Three modelling studies^{112,114,113,61} are potentially relevant for UK decision making. However, there are number of issues in the economic models identified that require further considerations (section 6.1 and 6.2). These include:

- The baseline age of the modelled cohort. The baseline age was not representative of the age of patients receiving first-line treatment in the UK.
- The sources of effectiveness for patients treated with CHOP, MCP and CHVPi in first-line induction treatment with or without rituximab. The effectiveness values were derived from trials where patients have received subsequent treatment such as interferon maintenance or SCT. Further details are available in the section 5.2.2.
- The source of effectiveness in patients receiving second-line treatment induction with or without maintenance rituximab. The effectiveness values were derived from patients not previously treated with rituximab. Additionally, in the MS,⁶¹ the time period when patients receive second-line induction treatment and outcomes for non-responders were not captured.
- The choice of utility values. There was a mismatch between the utility values used and the health states.
- Costs for patients treated in second-line or in progressive disease; errors/inconsistencies were identified in the model in the MS.⁶¹
- Constraints imposed by the chosen model structure. The identified models used a Markov approach which required strong assumptions about timing and progression rate. For example, the manufacturer fitted Exponential distributions in patients treated in second-line and these did not fit the data.
- Incorporation of death from non-FL causes.

6.4 Independent economic assessment

6.4.1 Methods

Introduction

The review of published economic evaluations^{112,114,113,116} were used. The main limitations identified were the description of the treatment pathway, the sources of effectiveness and assumptions that were made.

Previous guidance by NICE (TA110) was issued for the use of rituximab in combination with CVP for the first-line induction treatment of FL.⁸⁰ Since this guidance was produced, the license of rituximab was extended for use in combination with any chemotherapy containing regimen.⁸² In 2008, NICE issued guidance recommending the use of rituximab in combination with chemotherapy in second-line induction treatment and for rituximab monotherapy as maintenance treatment in patients responding to second-line induction chemotherapy with or without rituximab.⁷⁰ At the time of writing, NICE is currently considering the use of rituximab monotherapy for first-line maintenance treatment of patients responding to first-line induction treatment with rituximab in addition to chemotherapy.¹²⁸ The final guidance is expected to be issued after delivery of this assessment report. A summary of previous guidance issued by NICE is presented in section 3.2 (Table 4).

This section describes the development of a *de novo* economic model addressing the main limitations identified in existing economic evaluations.^{112,114,113,61,116} The key objective of the economic assessment is to address the cost-effectiveness of the addition of rituximab to chemotherapy in previously untreated, stage III/IV, FL patients in England and Wales in line with changes in the licensing of rituximab⁸² and previous guidance issued by NICE.^{80,70}

Population appraised

The population under assessment is previously untreated, symptomatic, stage III-IV FL patients in England and Wales.

Interventions/comparators

A probabilistic decision analytic model was developed to estimate the costs and quality adjusted life years (QALYs) of the addition of rituximab to three chemotherapy regimens: CVP; CHOP and MCP. The choice of chemotherapies was primarily based upon available data,^{94,95,90,91,92} the robustness of the evidence and to address the NICE scope defined for this appraisal.¹³⁴

No comparison was provided for the addition of rituximab to a CHVP regimen with interferon. This was due to issues in the design of the FL2000 trial⁹³ which compares the addition of rituximab to a CHVP regimen with interferon. There were differences in the interventions in the FL2000 trial.⁹³ The control/comparator group received 12 courses of a CHVP regimen administered every 28 days for 6 courses and then every 56 days for an additional 6 courses combined with 18 months of interferon, whereas the active treatment group received only 6 courses of a CHVP regimen administered every 28 days in addition to rituximab, with interferon delivered for 18 months. Clinical opinion suggests that CHVP regimens are very rarely used in the UK, and that interferon might not be used due to toxicity.

Description of the de novo economic model

The main source of effectiveness data was obtained from the three main trials conducted in first-line induction treatment which compared CVP against R-CVP,^{94,95} CHOP against R-CHOP^{90,91} and MCP against R-MCP.⁹²

The economic model was programmed using R 2.11.1 software[®] and uses a 25-year time horizon in the base case to capture costs and benefits as in the MS.⁶¹ Shorter horizons (5 years; 10 years) and a lifetime horizon are presented in sensitivity analyses. In accordance with the NICE guide for the methods of technology appraisal,⁹⁶ the economic model adopts the perspective of the UK NHS and personal social services (PSS) with costs and benefits discounted at an annual rate of 3.5%.

Treatment pathway and clinical practice in the UK

The modelled treatment pathway incorporates guidance issued by NICE^{70,80} for the treatment of FL patients in England and Wales and tries to replicate the treatment pathway observed in clinical practice. Due to the possibility that first-line maintenance rituximab could be recommended by NICE, an alternative scenario including this option has been included.

Clinical opinion was sought and two clinicians completed a short questionnaire via a telephone interview. A summary of the answers is presented in Table 33. Overall, clinical opinion suggested that:

- In clinical practice, patients relapsing within 6-12 months after rituximab in combination with chemotherapy are not likely to be re-treated with rituximab as recommended by the ESMO guideline.¹⁸ An exception was for patients previously treated with R-CVP.
- Anthracycline containing regimens (CHOP, MCP) can only be given once in a lifetime. Thus in second-line treatment, patients previously treated with an anthracycline containing regimen will be considered for alternative treatments with salvage therapy (High-Dose Therapy - HDT) with or without rituximab in addition to autologous stem cell transplantation (ASCT), if aged less than 65 years and are fit enough. Older or unfit patients are likely to receive less aggressive chemotherapies with or without rituximab, such as Fludarabine, Cyclophosphamide (FC). Rituximab may not be given in second-line as part of the salvage treatment for those patients previously treated with rituximab that relapse within 6-12 months after first-line induction treatment.
- Patients who are not in complete or partial remission at the end of first-line induction treatment (i.e. stable disease) with chemotherapy with or without rituximab are likely to be offered second-line treatment despite the absence of progression.

Table 33: Tabulated summary of the “most likely” treatment options in patients treated in first-line induction with CVP or CHOP with or without rituximab as indicated by clinical experts

Response status and time of relapse	First-line therapy				
		CVP	R-CVP	CHOP	R-CHOP
	Age				
Relapse within 6 months after start of therapy (non responders)	<65 years	R-CHOP	R-CHOP	R-HDT (+/- ASCT)	HDT (+/- ASCT)
	≥ 65 years	R-FC	R-FC	R-FC	FC
Responders at 6 months, but relapse within 6 months after end of therapy	<65 years	R-CHOP	R-CHOP	R-HDT (+/- ASCT)	HDT (+/- ASCT)
	≥ 65 years	R-FC	R-FC	R-FC	FC
Responders at 6 months, but relapse more than 6 months after end of therapy	<65 years	R-CHOP	R-CHOP	R-HDT (+/- ASCT)	R-HDT (+/- ASCT)
	≥ 65 years	R-FC	R-FC	R-FC	R-FC

ASCT= autologous stem cell transplant; HDT= high dose chemotherapy

Clinicians were only asked to define the treatment pathway in patients treated with CVP or CHOP containing regimens with or without rituximab. The pathway for MCP and R-MCP were assumed to be identical to CHOP and R-CHOP on the rationale that both were anthracycline regimens. The AG stresses that the treatment pathway defined in Table 33 is a simplification of treatment options given in second-line and acknowledges that the treatment decisions taken includes other parameters such as the presence of comorbidities and patient’s preferences.

The treatment pathways used in the economic model are presented in Figures 10, 11, 12 and 13 based on our discussions with clinical experts (Table 33) and previous guidance issued by NICE.^{70,80} Within the model, an age cut-off of 65 years was selected to classify eligibility for treatment in second-line; however the AG acknowledges that in clinical practice, patient age would not be the sole criteria as older patients who were fit enough may be eligible for SCT. Non-responders that did not progress at the end of treatment induction, were assumed to receive second-line treatment at the end of first-line induction treatment. Furthermore, we considered early relapse as relapse within 12 month after start of treatment.

For the scenario analysis, clinical opinion was sought to determine the treatment pathway after first-line maintenance treatment in patients treated in first-line induction with rituximab. This is largely unknown as first-line maintenance is not currently part of clinical practice. After discussion with clinical experts, the treatment pathway presented in Table 34 was used in the economic model for responders to first-line induction with rituximab in addition to chemotherapy.

Note that the choice of second-line for patients treated with chemotherapies only (i.e. without rituximab) in first-line induction was not amended (Figures 10, 11, 12 and 13) as first-line maintenance is only considered an option by NICE in the ongoing appraisal for patients treated with rituximab in addition to chemotherapy in first-line induction therapy.

Table 34: Treatment pathway incorporating maintenance

Response status and time of relapse	Age	R-CVP	R-CHOP/R-MCP
		Second-line treatment	
Relapse within 12 months after start of induction therapy (i.e. relapse after about less than 6 months after start of maintenance)	<65 years	CHOP	HDT (+/- ASCT)
	≥ 65 years	FC	FC
Relapse after 12 months after start of induction therapy (i.e. relapse after more than 6 months after start of maintenance)	<65 years	R-CHOP	ASCT
	≥ 65 years	R-FC	R-HDT (+/- ASCT)

ASCT= autologous stem cell transplant; HDT = High Dose Therapy

Figure 10: Treatment pathways modelled in the economic model for CVP

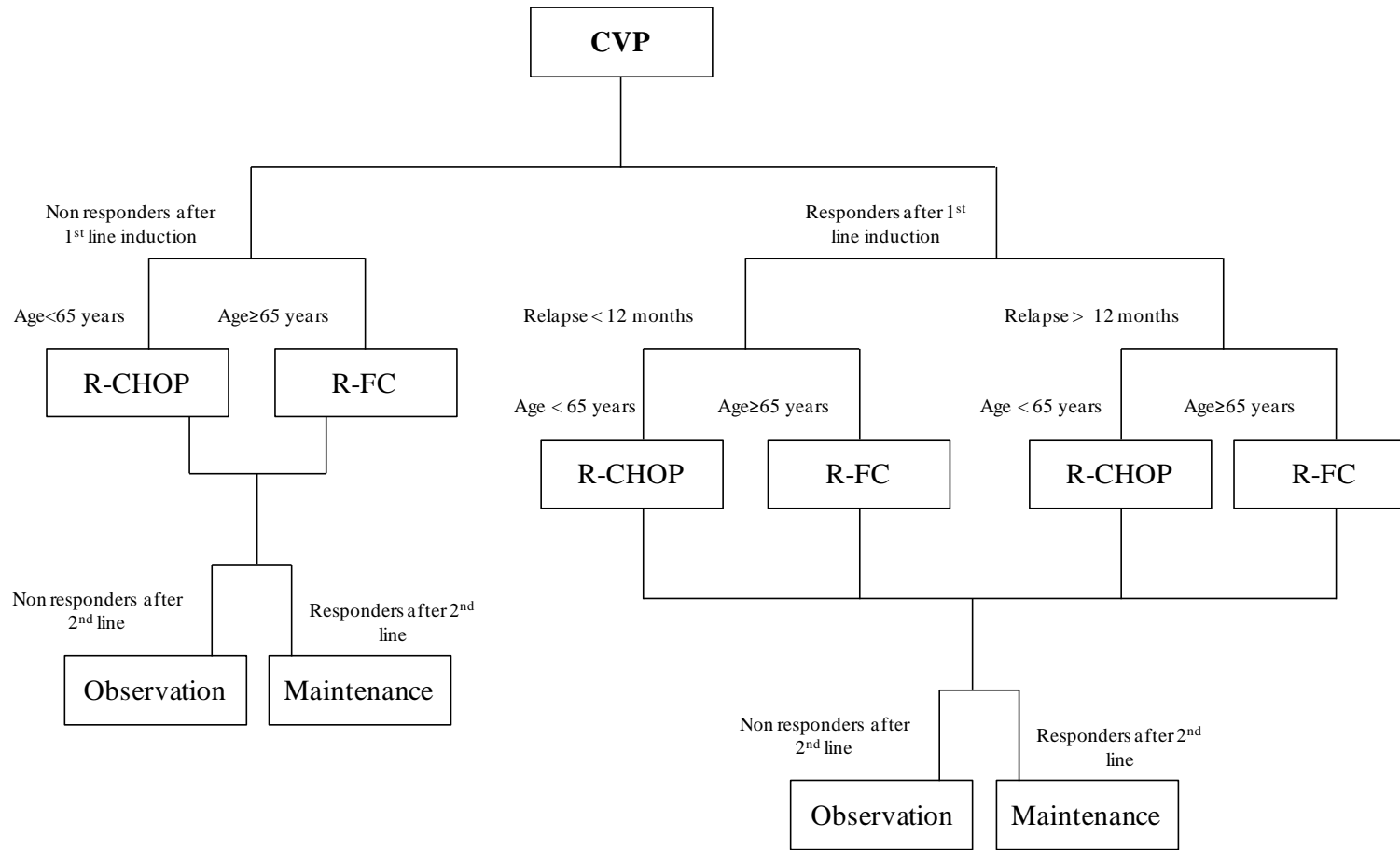

Figure 11: Treatment pathways modelled in the economic model for R-CVP

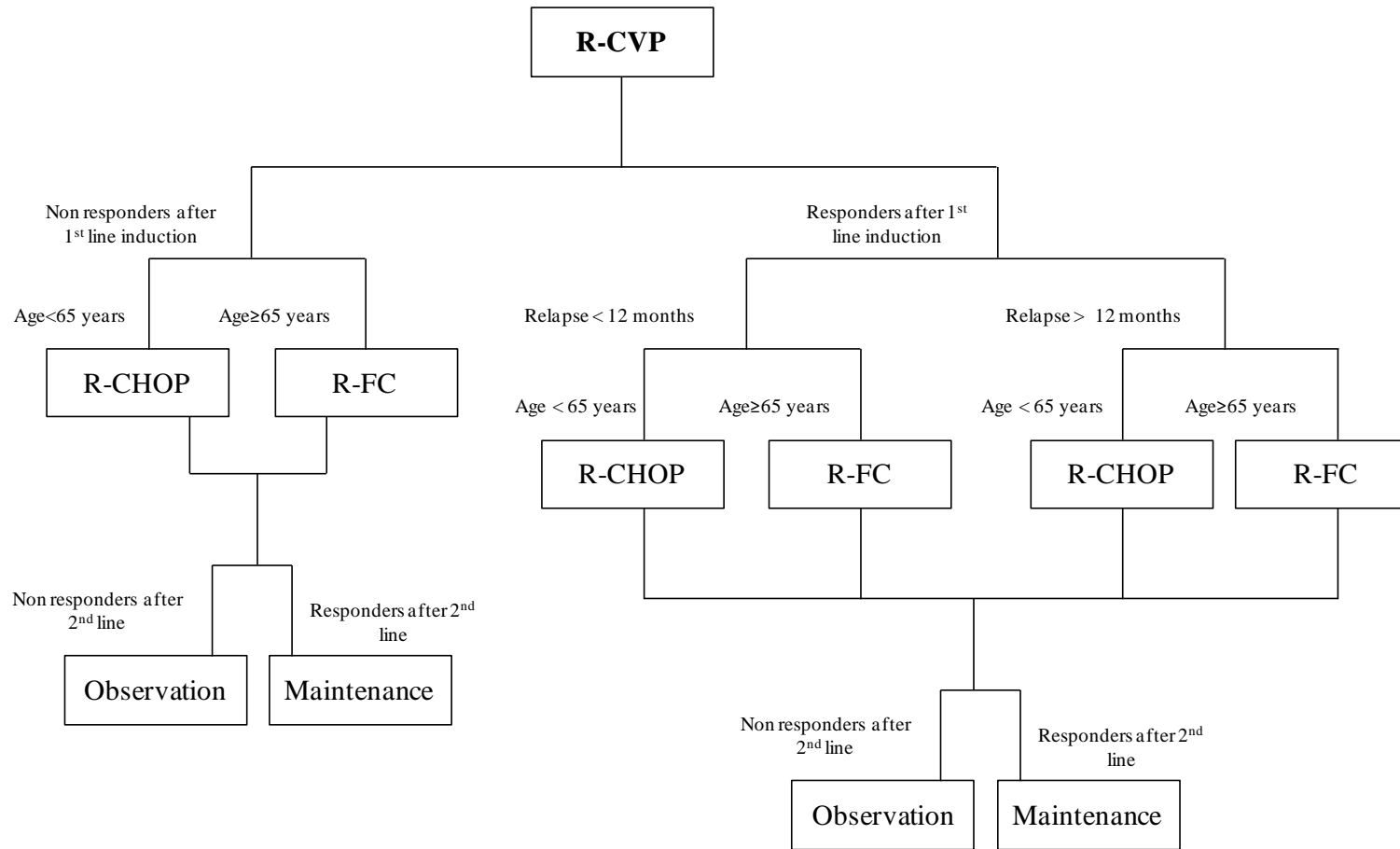

Figure 12: Treatment pathways modelled in the economic model for CHOP/MCP

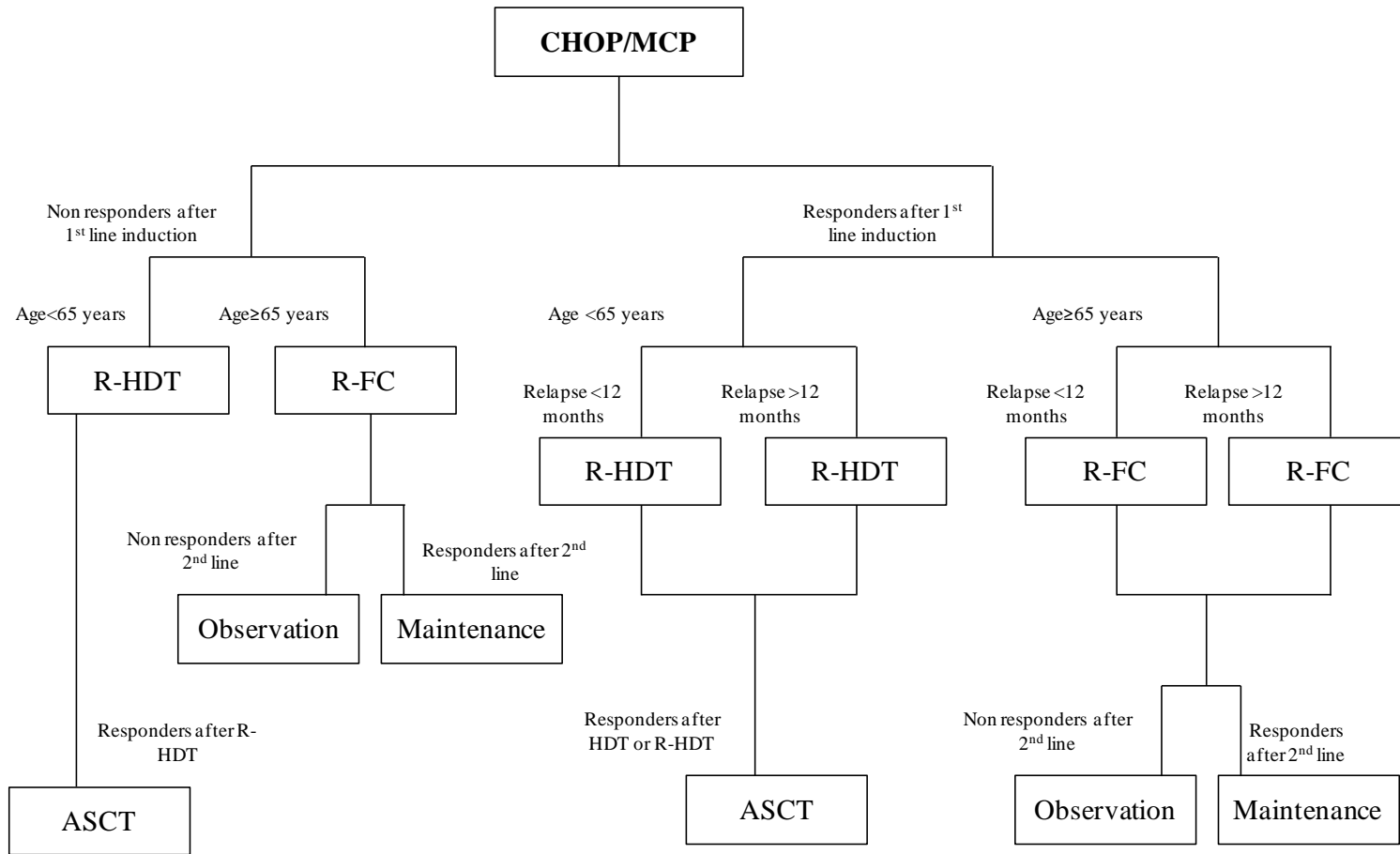
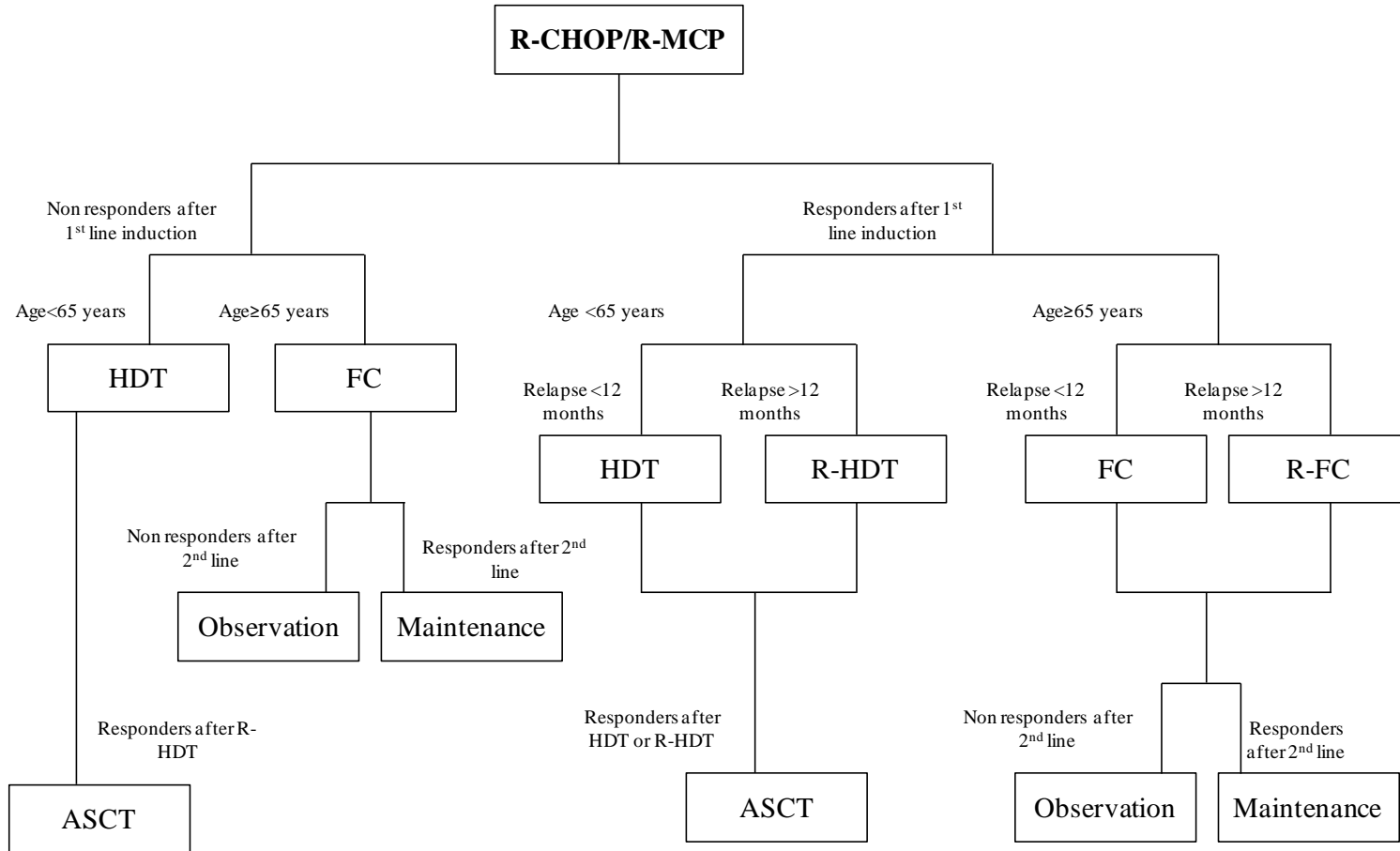

Figure 13: Treatment pathways modelled in the economic model for R-CHOP/R-MCP



In addition to the base case, a range of sensitivity analyses were conducted exploring the impact of the treatment pathway. As described later (see section about the effectiveness in second-line, p.139-145), there is a gap between evidence available and the treatment in clinical practice. No robust evidence were available for the effectiveness of FC containing regimens with or without rituximab in patients aged 65 years or older at the time of relapse after first-line induction treatment. There were also no trials identified providing a direct comparison of autologous stem cell transplant (ASCT) in addition to salvage therapy with HDT with or without rituximab in relapsed FL patients. Finally, the identified studies in relapsed FL patients^{135,71,72} were conducted in cohorts of FL patients that were not previously treated with rituximab (see section about resistance on p.146).

The following assumptions were explored in sensitivity analyses;

- Patients previously treated with R-CVP not being re-treated with rituximab if relapsing less than 12 months after the start of treatment (in the base case, those patients receive rituximab despite early relapse).
- Patients previously treated with an anthracycline containing regimen and aged less than 65 years old receiving CHOP or R-CHOP in second-line (in the base case, those patients receive salvage therapy with or without rituximab +/- ASCT).
- Patients aged over 65 years old receiving a CHOP containing regimen (CHOP or R-CHOP) (in the base case, those patients receive FC or R-FC).
- Patients receiving second-line treatment after progression only (in the base case, patients with stable disease at the end of treatment induction are considered to be non-responders and undergo further line of treatment).

An additional scenario is also presented assuming that patients responding to first-line induction treatment with rituximab in combination with chemotherapy receive first-line maintenance rituximab for up to 2 years. This scenario is presented to explore the potential impact of the addition of first-line maintenance into the treatment pathway if NICE issue positive guidance. No final guidance was issued by NICE at the time of writing of this report.¹²⁸

Definition of progression

In the economic model, the need for further treatments is driven by the presence of progression, i.e. that patient receive second-line treatment only after relapse/progression. However trials use different definitions for the time to progression (see section 5.2.2 and Appendix 12). A comparison of time to treatment failure (TTF) (that includes next anti-lymphoma treatment and stable disease at 4 cycle as event), time to progression (TTP) and time to next anti-lymphoma treatment (TNNT) curves from the

M39021 trial^{95,94} suggests that some patients might have received further/second-line treatments before progression.

In the economic model, we used TTP from the M39021 trial^{94,95} as patient level data were available (Data provided by Roche, Personal Communication, 15/02/2011) for this outcome. PFS or EFS have been used in second-line according to the data available. The AG acknowledges the potential differences between the outcomes, and refers to progression outcomes as PFS for simplicity and consistency.

Structure of the economic model

The structure of the economic model developed by the AG is similar to the model included in the MS⁶¹ in terms of health states, with patients moving between four possible health states: PFS1 (first-line induction treatment/progression-free), PFS2 (second-line/progression-free), progressive-disease (including subsequent lines of chemotherapy) and death.

Health states were selected to represent the natural history in FL patients to incorporate previous NICE guidance.⁷⁰ The AG acknowledges that patients are likely to receive more than two lines of therapy in clinical practice; however, there are no robust evidence available which would allow the effectiveness after second-line treatment to be modelled with accuracy.

The economic model developed by the AG for this appraisal differs from the economic model included in the MS⁶¹ in the following manner;

- Use of a continuous time method over a traditional Markov process,
- Treatment pathways reflecting more accurately clinical practice in England and Wales (Figure 10, 11, 12 and 13),
- Responders and non-responders are modelled as two separate subgroups,
- Use of a different source of evidence to model the effectiveness in patients treated with CHOP or MCP with or without rituximab (see section about the effectiveness of R-CHOP and R-MCP on p.133-137).

The economic model treats responders and non-responders as two separate sub-groups and therefore does not use the PFS curve calculated for the whole trial population. This choice has been made after reviewing the evidence available in first-line induction for patients treated with CHOP or MCP with or without rituximab (see section about the effectiveness of R-CHOP and R-MCP in first-line induction in p.133-137). The structure facilitates the implementation of maintenance after first or second-line induction treatment.^{70,128}

A simplified schematic of the model structure is provided in Figure 14. A cohort of 100,000 individual patients were simulated, each with individual demographic characteristics (age, gender and body surface area - BSA). The age at death due to non-FL causes was sampled from a Gompertz distribution estimated from life tables in the UK¹³⁶ conditional on the patient being alive at the start of the simulation. In PFS1, patients received CVP, CHOP or MCP with or without rituximab. Patients remaining in PFS1 at the end of the induction treatment were assumed to be monitored but to not receive any further treatments. For each of the therapies examined, the response rates from the applicable trials^{94,95,90,91,92} were used to classify patients into responders and non-responders.

Figure 14: Schematic of the model structure

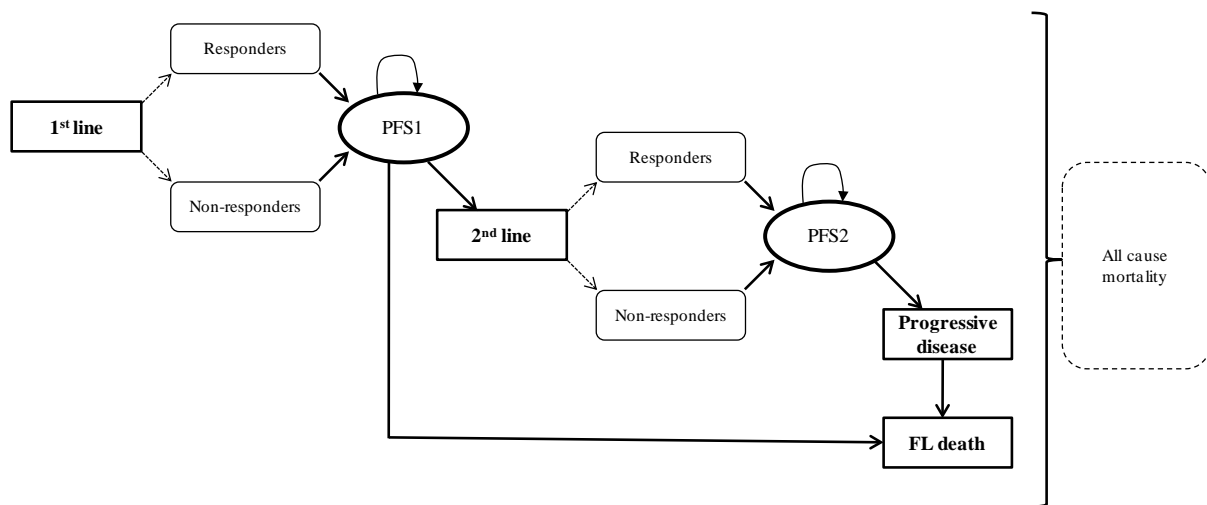

The time to progression is then sampled according to the PFS curves for responders and non-responders as appropriate, with non-responders having a faster disease progression (see Figure 27). If the estimated time of progression is later than the estimated time to non FL death, patients are assumed to die before progression. For patients progressing before the age at death from all causes, the event (relapse or death) is determined based on the proportion of progression attributable to death (see section about death in PFS1 in p.158). Patients do not continue in the simulation if progression is attributable to death. Patients dying incur no further costs and accrue no further QALYs. Patients relapsing move to second-line treatment.

Patients treated in second-line are classified as either responders or non-responders. Responders to CHOP, R-CHOP, FC or R-FC receive maintenance rituximab for up to two years at the end of the induction phase as per NICE guidance.⁷⁰ Patients responding to HDT or R-HDT receive ASCT. Patients remaining in PFS2 at the end of treatment induction, maintenance or ASCT are assumed not to receive further treatment but would be monitored. The time to progression is sampled and patients who progress before the age at death from all causes receive further lines of therapies

(third/subsequent line). The time to death from the receipt of second-line treatment is also calculated to identify the cause of death (FL or all causes). Patients dying incur no further costs and accrue no further QALYs. Patients relapsing move to progressive disease. Those patients are assumed to incur additional costs associated with palliative and terminal care as appropriate.

Patient characteristics

A patient’s baseline characteristics was derived from registry data in England^{3,136} and Wales^a and the demographics from the trials conducted in patients with FL.

Gender

The proportion of male patients (47%) is estimated from registry data in England³ and Wales^a.

Baseline age

The baseline age is derived from registry data in England³ and Wales^a using a two-stage process. For consistency, a 5-year age band was assumed for patients aged 85+ (Figure 15). We then estimated the age within each age-band assuming a uniform distribution (i.e. equal probability). Firstly, the age-band of the patients was sampled. Then the precise age was estimated assuming a uniform distribution within the age-band.

Figure 15: Age-distribution of patients diagnosed with FL in England³ and Wales^a

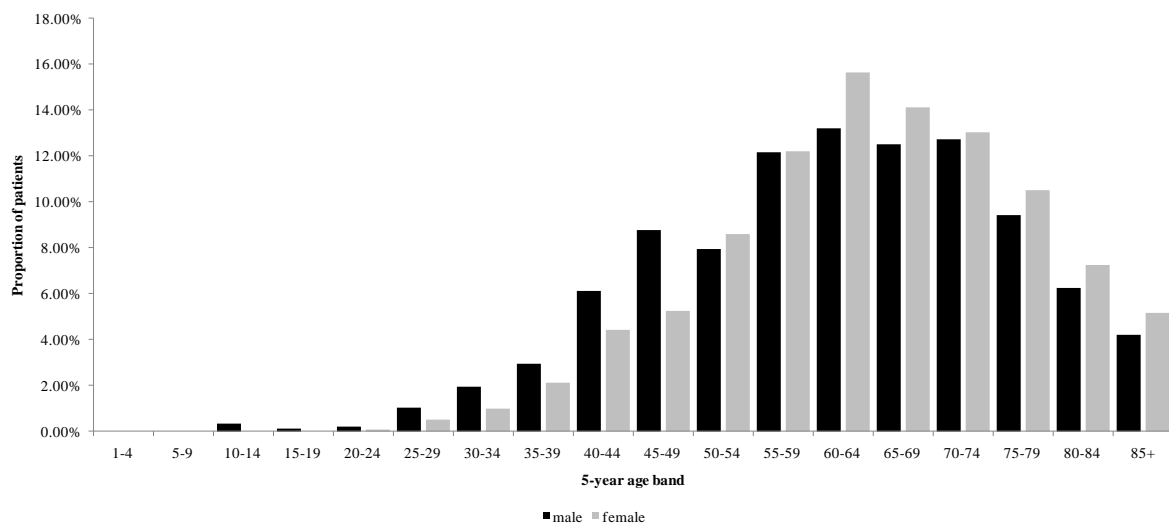

^a Data provided by the Welsh Cancer Intelligence & Surveillance Unit, 2008

Body surface area

The body surface area (BSA) is estimated from the height (cm) and weight (kg) of patients from patient-level data from the PRIMA study^{69,125} by gender using the Mosteller formula: $\sqrt{(\text{cm} \cdot \text{kg}) / 3600}$ (Table 35). Age-specific BSA values were considered but were not used as the use of an average greatly reduced the uncertainty associated with the BSA.

In the Probabilistic Sensitivity Analysis (PSA), height and weight were sampled independently assuming no correlation. Whilst this is a limitation, we did not have access to patient level data from the trial.⁶⁹

Table 35: Height, Weight and estimated BSA in FL patients from the PRIMA study^{69,125} by gender

	Height (cm±sd)	Weight (kg±sd)	Estimated BSA (Mosteller formula)
Male	175.01±7.3	79.68±13.34	1.97
Female	161.44±6.75	67.83±14.39	1.74

Age at death from all causes

The age at death from all causes is derived from UK life table data¹³⁶ by fitting a Gompertz distribution to the data for males and for females.

The coefficients of the Gompertz distribution are presented in Table 52 (p.168-169). The AG acknowledges a limitation in the approach used, namely that deaths from FL were not excluded from the survival curve and therefore, double counting may occur. However, as it is possible that some of the deaths observed in the trials may be due to non-FL causes this may be partly offset. The AG believes that the exclusion/inclusion of FL related deaths from life tables data is likely to have a very minimal impact on the ICER.

Response rate after first-line induction treatment

In the economic model, patients are separated into responders and non-responders according to the response rates after first- or second-line induction treatment. The response rates in first-line were extracted from the proportion of responders observed in the three main first-line remission induction trials (Table 36).^{94,95,90,91,92}

Table 36: Response rate in first-line induction

First-line	CVP ^{94,95}	R-CVP ^{94,95}	CHOP ^{90,91}	R-CHOP ^{90,91}	MCP ⁹²	R-MCP ⁹²
Total number of patients	159	162	278	279	96	105
Number of responders	90	131	253	268	72	97
Response rate	56.60%	80.86%	90.01%	96.06%	75.00%	92.38%

Due to absence of relevant data for PFS by response category, no distinction was made between partial and complete responders.

PFS in patients treated with CVP in first-line induction with or without rituximab

PFS in responders to CVP and R-CVP

Individual patient level data from the M39021 trial^{94,95} have been provided by the manufacturer after a request from the AG (Roche, Personal Communication, 15/02/2011). The manufacturer provided the KM plots from first randomisation (i.e. from start of treatment) and consequently, the KM curve is flat for responders for the first 6 months corresponding to the initial period of induction treatment. Because of this, it was not appropriate to fit a distribution the entire KM curve. Consequently, in the economic model, we assumed no progression for responders during treatment induction (196 days for 8 cycles of 21 days + 28 days), with a distribution fitted from the end of this period.

To preserve the correlation between treatments in the PSA, the AG fitted a parametric distribution to all responders using treatment as a covariate. This was shown to provide an adequate fit to the data (Figure 16, Figure 17, Figure 18). The parametric distribution was selected through an iterative process after evaluating goodness of fit criteria, the visual plot of the curve to the observed data, the plausibility of the extrapolation at the end of clinical evidence and the plot of the hazard.

Different parametric models incorporate different hazard functions. Exponential models are only suitable if the observed hazard is approximately constant and positive. Weibull and Gompertz models incorporate monotonic hazards, while the logged models (Log-logistic, Log-normal) can incorporate non-monotonic hazards but typically have long tails due to a reducing hazard as time increases beyond a certain point.¹³⁷

The Akaike Information Criteria (AIC) and Bayesian Information Criteria (BIC) were calculated which suggest that the Log-normal provides the best fit to the data (Table 37). Broadly similar AIC and BIC values were observed for the Log-logistic and Gompertz distribution. However, goodness of fit criteria only provides an indication of the goodness of fit to the observed period and do not categorically indicate that one distribution should be preferred to the remaining distributions. The observed KM were plotted against the five fitted parametric distributions (Exponential, Weibull,

Gompertz, Log-logistic and Log-normal). The Gompertz, Log-logistic and Log-normal distributions provided a plausible fit to the observed data (Figure 16 and Figure 17). Similarly, visual inspection of the plot of the hazard (Figure 18) suggests that the Log-normal, Log-logistic and Gompertz distribution were suitable as the plot was broadly linear.

As single parametric distributions provided reasonable and plausible fit to the data, the AG did not consider other methodologies such as the use of piecewise Exponentials.

Table 37: Goodness of fit criteria for the risk of progression among responders to CVP first-line induction with or without distribution^{94,95}

Model	Obs	ll(null)	ll(model)	df	AIC	BIC
Exponential	221	- 333.225	- 316.846	2	637.692	644.488
Weibull	221	- 330.528	- 315.636	3	637.271	647.466
Gompertz	221	- 322.177	- 309.133	3	624.266	634.460
Log-logistic	221	- 323.495	- 307.567	3	621.134	631.328
Log-normal	221	- 320.175	- 304.582	3	615.165	625.359

Analysis of individual patient level data provided by the manufacturer (Roche, personal communication, 15/02/2011)

Figure 16: Plot of the observed KM and predicted distributions for patients treated with CVP^{94,95}

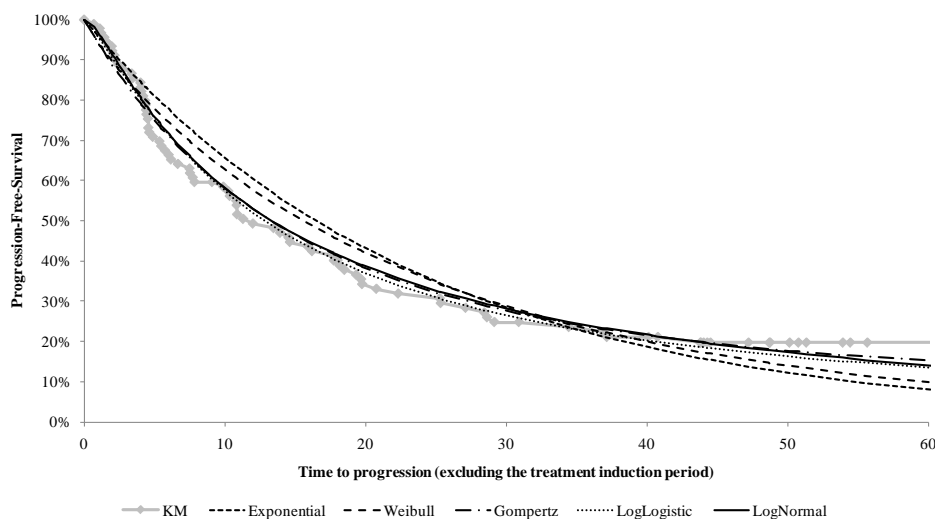

Analysis of individual patient level data provided by the manufacturer (Roche, personal communication, 15/02/2011)

Figure 17: Plot of the observed KM and predicted distributions for patients treated with rituximab in addition to CVP^{94,95}

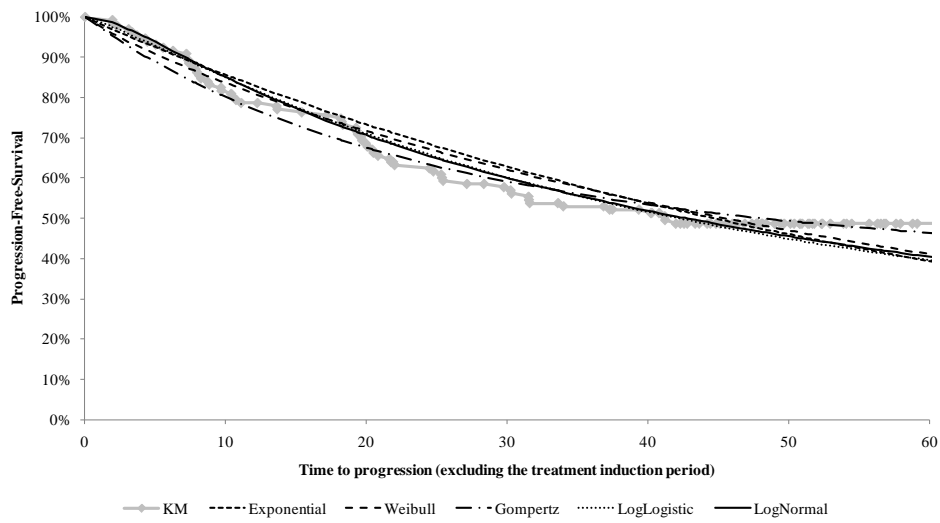

Analysis of individual patient level data provided by the manufacturer (Roche, personal communication, 15/02/2011)

Figure 18: Plot of hazard for responders treated with CVP with or without rituximab^{94,95}

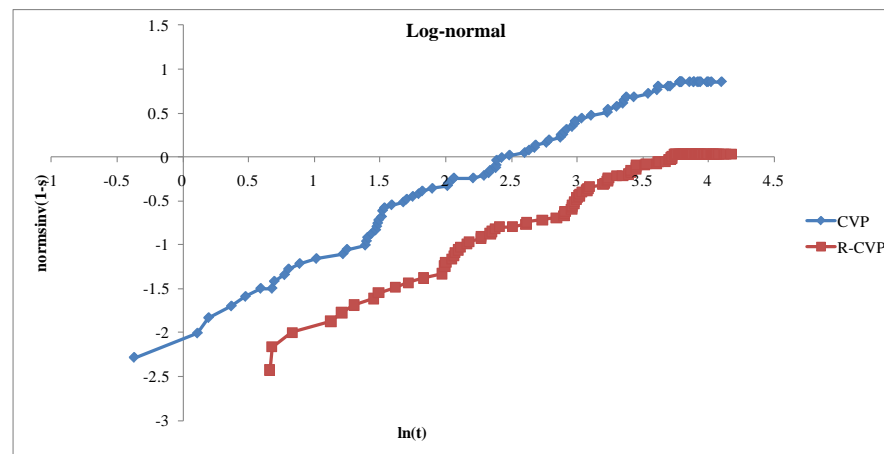
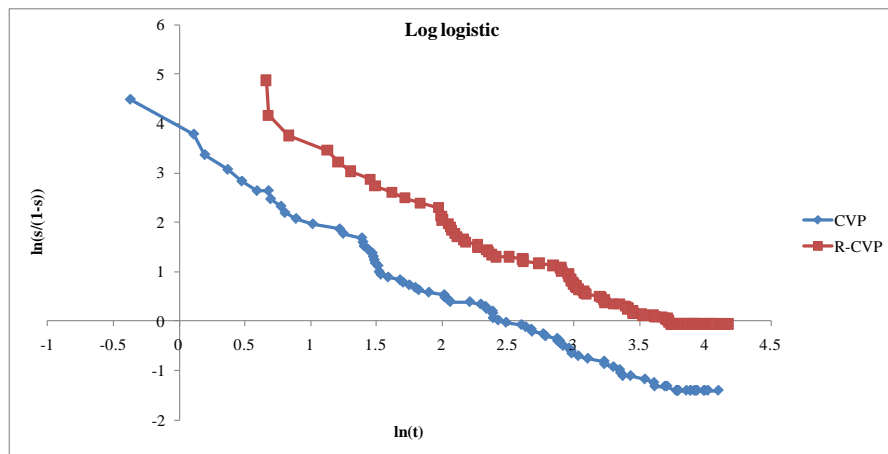
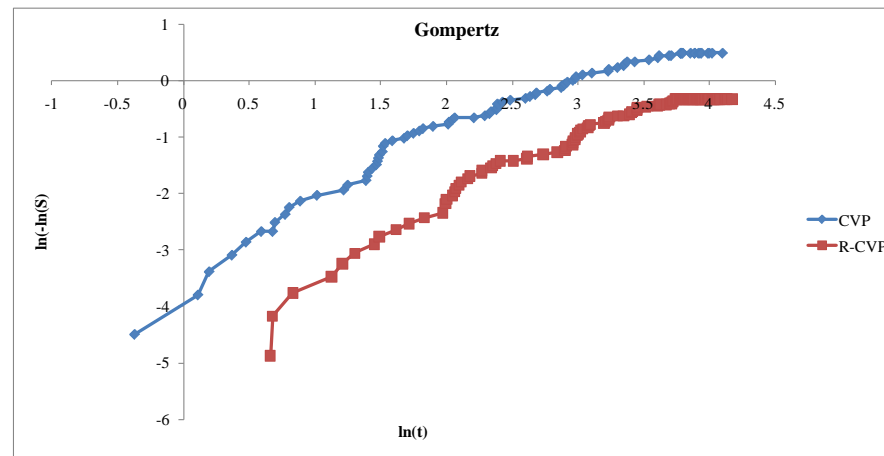
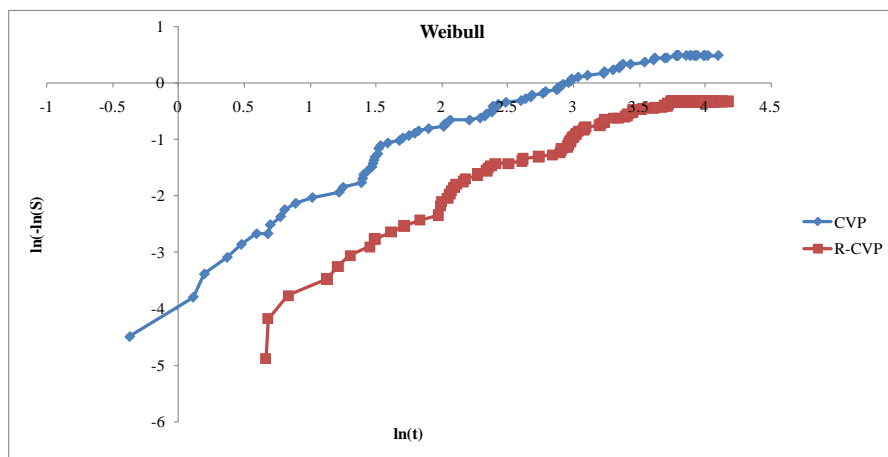

Analysis of individual patient level data provided by the manufacturer (Roche, personal communication, 15/02/2011)

From the values of the AIC/BIC, the visual inspections of the fit to the observed period and hazards, the AG believes that the Gompertz, Log-logistic and Log-normal distributions provided a reasonable and plausible fit to the data. However, the AG believed that the Log-normal distribution provided a more plausible long-term extrapolation compared to the Gompertz distribution (see Figure 44). The risk of progression using the Gompertz distribution flatten out after about 60 months, implying that about 40% of responders would never progress. FL is considered as an incurable disease and therefore the use of the Gompertz distribution may be implausible. In the base case, the Log-normal distribution was selected by the AG as this was believed to be the most plausible parametric extrapolation. The Weibull and Gompertz distributions have been used in sensitivity analysis as these provided a different extrapolation. The AG did not test the Log-logistic as the curve was very similar to the Log-normal distribution. The Log-normal regression model and variance-covariance matrix are presented in Figure 19.

Figure 19: Log-normal regression model for responders to CVP containing regimen with or without rituximab^{94,95}

No. of subjects	=	221	Number of obs	=	221		
No. of failures	=	136					
Time at risk	=	5913.331					
			LR chi2(1)	=	31.18		
Log likelihood	=	-304.582	Prob > chi2	=	0		

<u>_t</u>	Coef.	Std. Err.	z	P>z	[95% Conf.	Interval]
trt	1.16341	0.204687	5.68	0	0.76223	1.56459
_cons	2.591318	0.152575	16.98	0	2.292276	2.89036
/ln_sig	0.335348	0.065793	5.1	0	0.206395	0.464301
sigma	1.398427	0.092007			1.229239	1.590901

Variance-Covariance Matrix

	<u>_t:</u>	<u>_t:</u>	ln_sig:
	trt	_cons	_cons
<u>_t:trt</u>	0.041897		
<u>_t:_cons</u>	-0.02258	0.023279	
ln_sig:_cons	0.001846	0.001042	0.004329

Analysis of individual patient level data provided by the manufacturer (Roche, personal communication, 15/02/2011)

PFS in non-responders to CVP and R-CVP

A similar process to that detailed for responders to CVP and R-CVP has been employed to estimate the risk of progression among non-responders to CVP and R-CVP; however KM data from the start of treatment induction was used^{94,95} (Data provided by Roche, Personal Communication, 15/02/2011). The goodness of fit criteria (Table 38), visual plot of the KM to the observed period (Figure 20 and Figure 21) and the plot of the hazard (Figure 22) indicates that the Gompertz, Log-logistic and Log-normal again provide a plausible fit to the data. In the base case analysis, the Log-normal distribution was selected (Figure 23) with other distributions tested in sensitivity analysis.

Table 38: Goodness of fit criteria for the risk of progression among non-responders to CVP first-line induction with or without distribution^{94,95}

Model	Obs	ll(null)	ll(model)	df	AIC	BIC
Exponential	93	- 158.965	- 158.490	2	320.979	326.044
Weibull	93	- 156.174	- 155.819	3	317.637	325.235
Gompertz	93	- 149.751	- 149.509	3	305.019	312.616
Log-logistic	93	- 147.759	- 147.431	3	300.863	308.461
Log-normal	93	- 147.316	- 147.070	3	300.139	307.737

Analysis of individual patient level data provided by the manufacturer (Roche, personal communication, 15/02/2011)

Figure 20: Plot of the observed KM and predicted distributions for non-responders treated with CVP^{94,95}

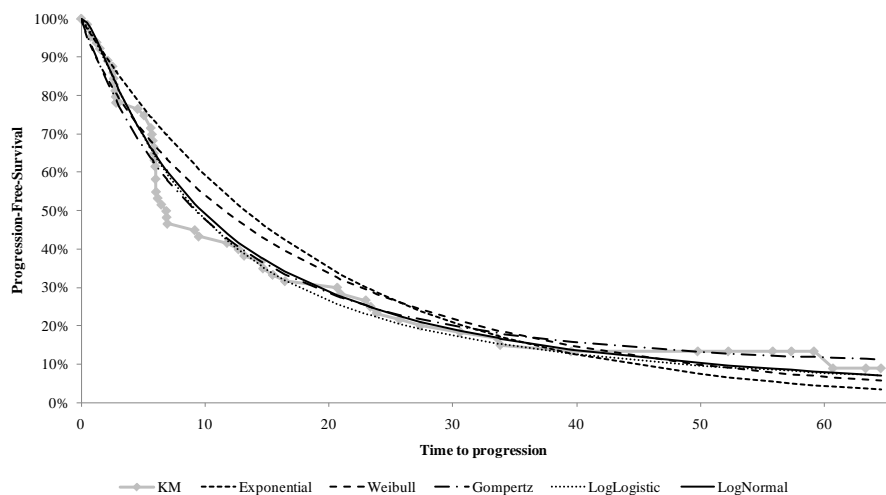

Analysis of individual patient level data provided by the manufacturer (Roche, personal communication, 15/02/2011)

Figure 21: Plot of the observed KM and predicted distributions for non responders treated with rituximab in addition to CVP^{94,95}

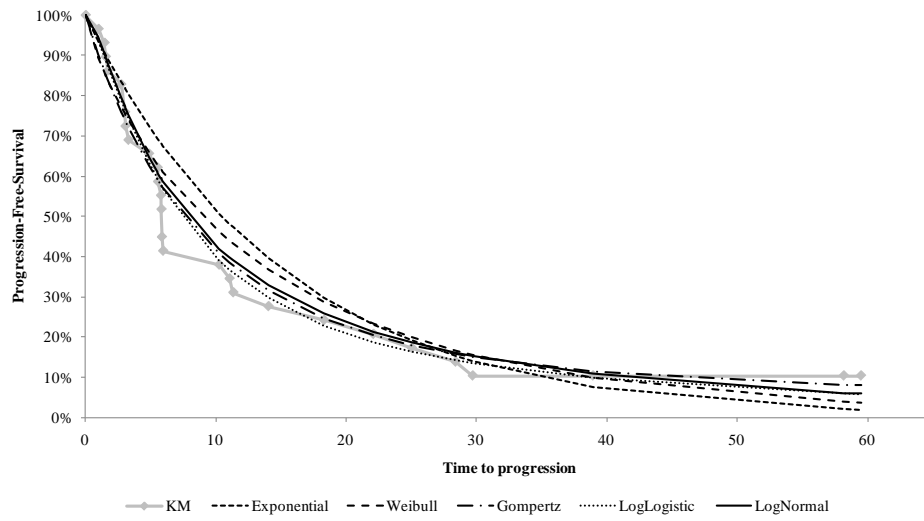

Analysis of individual patient level data provided by the manufacturer (Roche, personal communication, 15/02/2011)

Figure 22: Plot of hazard for non-responders treated with CVP with or without rituximab^{94,95}

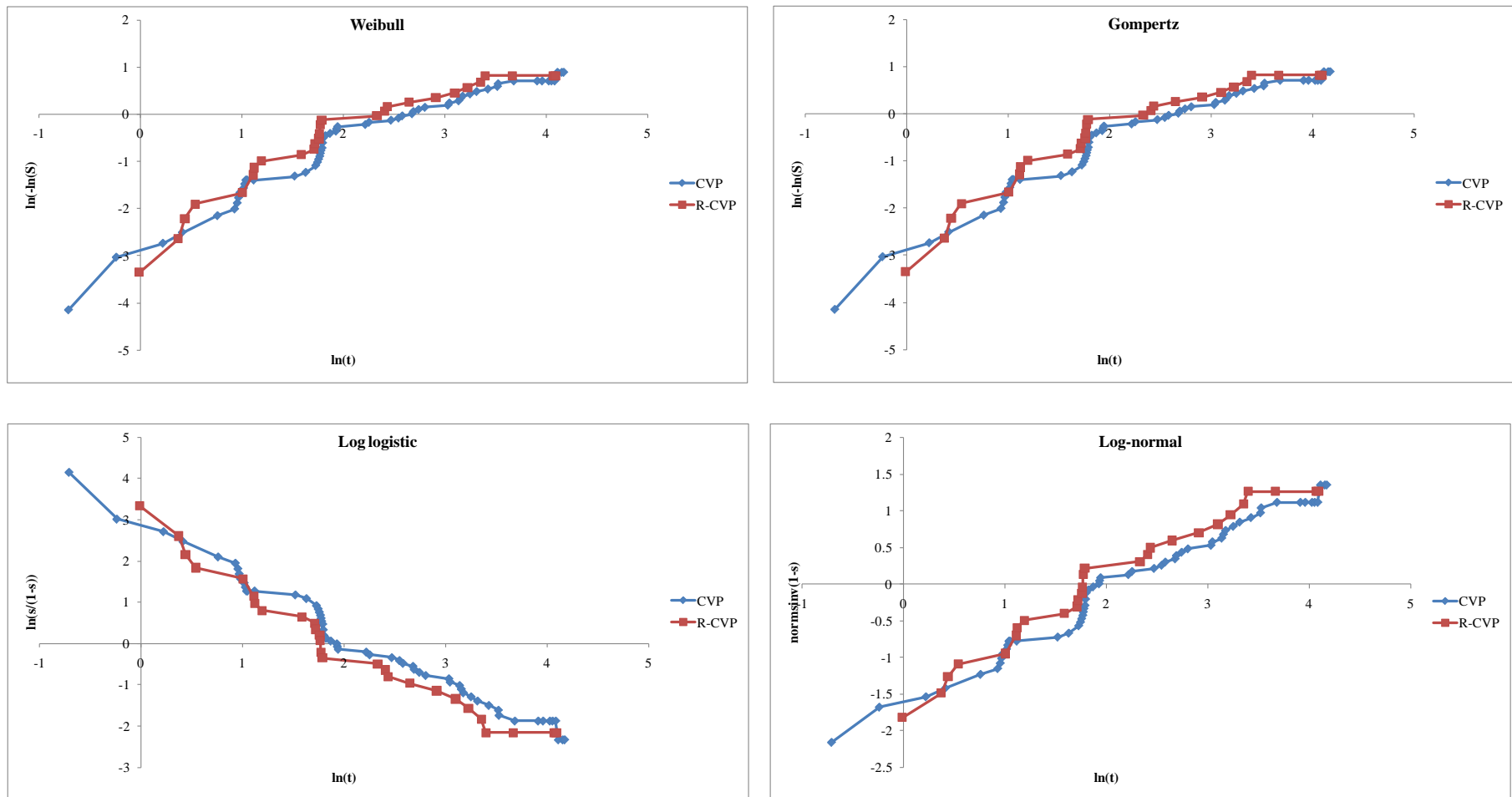

Analysis of individual patient level data provided by the manufacturer (Roche, personal communication, 15/02/2011)

Figure 23: Log-normal regression model for non-responders to CVP containing regimen with or without rituximab^{94,95}

No. of subjects	=	93	Number of obs	=	93
No. of failures	=	80			
Time at risk	=	1425.807			
			LR chi2(1)	=	0.49
Log likelihood	=	-147.07	Prob > chi2	=	0.4823

_t	Coef.	Std. Err.	z	P>z	[95% Conf.	Interval]
trt	-0.20573	0.292553	-0.7	0.482	-0.77912	0.367666
_cons	2.273996	0.16551	13.74	0	1.949602	2.59839
/ln_sig	0.254605	0.081224	3.13	0.002	0.095409	0.413802
sigma	1.289952	0.104776			1.100108	1.512558

Variance-Covariance matrix

	_t:	_t:	ln_sig:
	trt	_cons	_cons
_t:trt	0.085587		
_t:_cons	-0.02731	0.027394	
ln_sig:_cons	-0.00035	0.000945	0.006597

Analysis of individual patient level data provided by the manufacturer (Roche, personal communication, 15/02/2011)

PFS in patients treated with CHOP in first-line induction with or without rituximab

PFS in responders to CHOP and R-CHOP

In the GLSG 2000 trial,^{90,91} patients younger than 60 years of age achieving CR or PR following first-line induction treatment were randomised to either stem cell transplantation or maintenance with interferon. Patients aged 60 years and older received maintenance with interferon. Consequently, the reported effectiveness in responders is confounded by the effect of maintenance interferon or SCT.

The AG believes that data from the GLSG 2000 trial^{90,91} would lead to an overestimate of the absolute gain of the addition of rituximab to CHOP because of the additional treatments provided to responders. Alternative sources of effectiveness have therefore been considered to model the risk of progression among responders to CHOP first-line induction with or without rituximab.

The PRIMA study⁶⁹ provides data on the progression rate of patients responding to first-line induction with chemotherapy in combination with rituximab only (R-CVP, R-CHOP, R-FCM). Patients were randomised to maintenance rituximab or observation up to two years from the end of first-line treatment induction (R-CHOP, R-CVP or R-FCM). The majority of patients (90%) had stage IV FL and most of patients received R-CHOP as first-line induction treatment (74%).

Individual patient level data from the PRIMA study⁶⁹ were made available to the AG by the manufacturer (Roche, Personal Communication, 15/02/2011). The KM curves for the responders randomised to observation for R-CHOP and R-CVP from the end of treatment induction have been compared (Figure 24). Although apparently visually different, the difference between the two curves was not statistically significant ($p = 0.0970$). However, the AG acknowledges that the absence of statistical differences might be attributable to small sample sizes (R-CVP $n = 113$ and R-CHOP $n = 386$) and that this does not necessarily means that the two curves are similar.⁶⁹

Figure 24: Comparison of the KM for responders to R-CHOP and R-CVP in the PRIMA trial⁶⁹

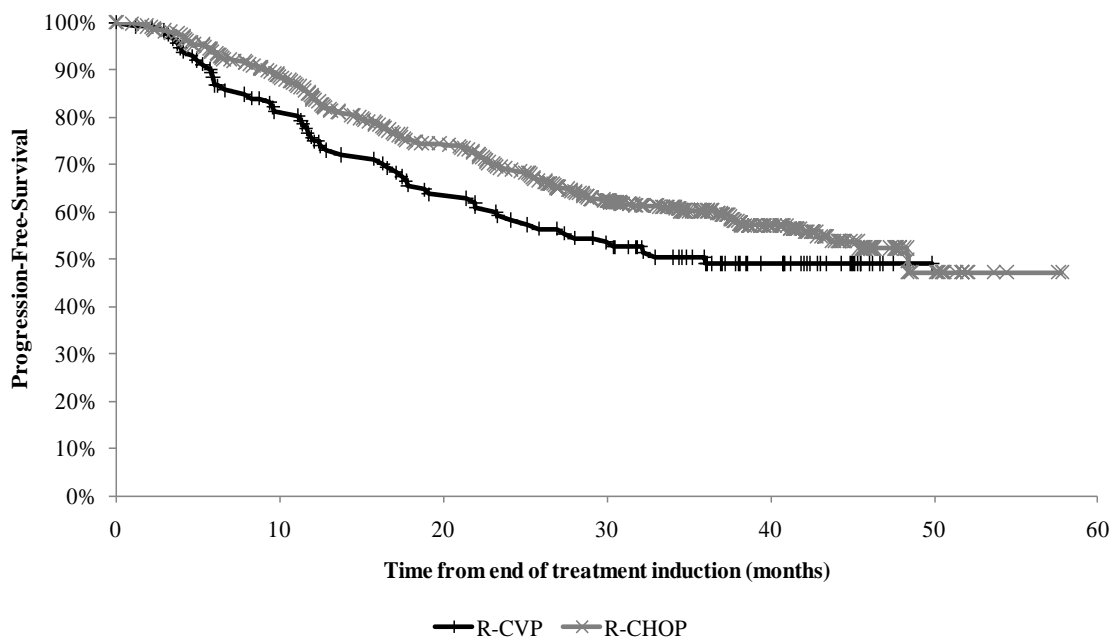

Analysis of individual patient level data provided by the manufacturer (Roche, personal communication, 15/02/2011)

No robust sources of effectiveness were identified for the risk of progression for patients treated with CHOP first-line induction without rituximab. Most of the studies identified have been conducted in populations with other lymphomas, used a different study designs (retrospective) or were confounded by subsequent therapies for patients in remission.^{138,139} Clinical opinion was sought about the mechanism of action of rituximab. This suggested that the addition of rituximab might provide the same relative benefit compared to chemotherapy alone irrespective of the choice of chemotherapy.

Whilst patient-level data from the PRIMA study⁶⁹ (Data provided by Roche, Personal Communication, 15/02/2011) could have been used, the AG was not comfortable to use direct data from the trial due to the high degree of censoring, which was noted by the ERG in the ongoing appraisal on rituximab for first-line maintenance treatment.¹²⁷ Furthermore, if a parametric function is fitted to patient-level data from the PRIMA trial,⁶⁹ the curve between R-CHOP and R-CVP curves would cross, as the curve for R-CVP becomes relatively flat after about 50 months. It is unclear if this is only an artefact of the limitation in the data used.^{69,95,94}

Given the limited evidence available on the progression for patients treated with CHOP and R-CHOP in first-line induction, the absence of a statistically significant difference for the risk of progression among responders to first-line induction with R-CVP and R-CHOP ($p = 0.0970$) and the suggestion by clinicians of a similar mechanism of action of rituximab for the different type of chemotherapies assessed, the AG used patient-level PFS data from the M39021 trial^{94,95} (Data provided by Roche, Personal Communication, 15/02/2011) as a proxy of the PFS for patients responding to CHOP and R-CHOP respectively.

The assumptions made were supported by additional analyses comparing the risk of progression among responders to R-CVP from the PRIMA trial⁶⁹ (Data provided by Roche, Personal Communication, 15/02/2011) and responders to R-CVP from the M39021 trial.^{94,95} (Data provided by Roche, Personal Communication, 15/02/2011) Overall, the PFS from end of treatment induction was found to be broadly similar between the two trials (Figure 25).

Figure 25: Plot of the risk of progression among patients responding to first-line induction treatment with R-CVP from the PRIMA⁶⁹ and M39021^{94,95} trials

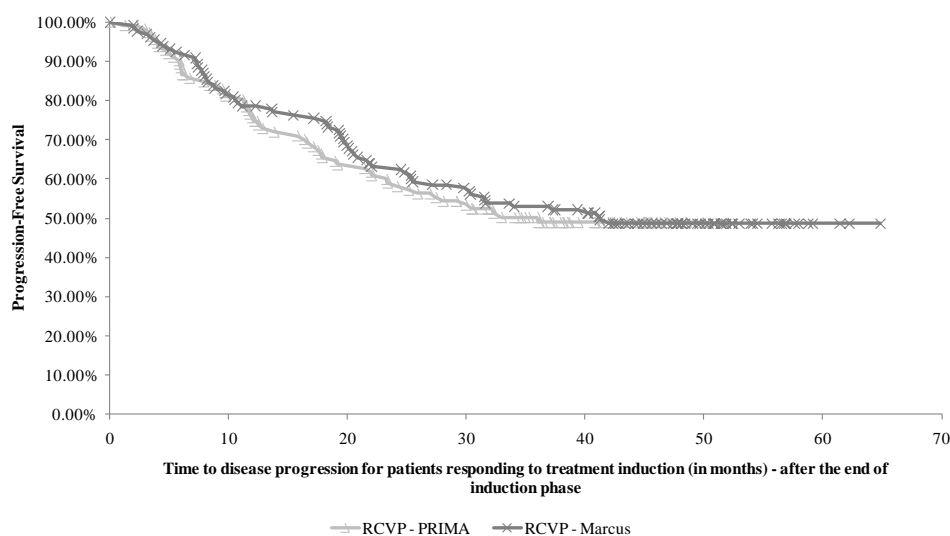

Analysis of individual patient level data provided by the manufacturer (Roche, personal communication, 15/02/2011)

PFS in non-responders to CHOP and R-CHOP

In the absence of evidence, the progression rates in patients that do not respond to first-line induction treatment with CHOP with or without rituximab were assumed to be equal to the rates of progression observed with CVP in combination with or without rituximab (see section about the effectiveness of CVP and R-CVP in first-line induction in p.125-133). Whilst this is a limitation, it is consistent with the assumption that the rates of progression for responders to CHOP and R-CHOP equalled that of CVP and R-CVP.

Additionally, it is believed that this assumption would have little impact on the ICER as only a small proportion of patients do not respond to first-line induction treatment with R-CHOP or CHOP (3.94% and 8.99% respectively).^{90,91} Clinical opinion was sought and suggested that this is a reasonable assumption.

Comparison of the modelled R-CHOP by the AG against data from an alternative RCT⁷⁵

Rummel *et al.*⁷⁵ reports data from a phase III trial comparing R-CHOP against R-bendamustine in patients treated for follicular, waldenstroms, marginal zone, small lymphocytic and mantle cell lymphoma. Fifty-four percent of patients had FL and patients treated with R-CHOP received a maximum of 6 cycles. The median age was 63 years old and 77% of patients had Stage IV disease. Thirty-three percent and 48% of patients randomised had a FLIPI score of 2 or 3 or greater respectively. The median observation time was 36 months. The response rate for all patients randomised to R-CHOP was 91.3% (all lymphoma types) and the median overall progression free survival (from randomisation) was 46.7 months in FL patients treated with R-CHOP in first-line induction (which included all FL patients). Whilst patients' characteristics for FL patients are not presented separately, patients' characteristics for the whole trial population randomised to R-CHOP⁷⁵ are broadly similar to the characteristics of the population included in other first-line induction trials for FL.^{94,95,90,91,92}

The PFS for FL patients from Rummel *et al.*⁷⁵ was compared to our estimated combined PFS (responders and non-responders) for patients treated with R-CHOP assuming a response rate of 91.3% and that patients receive up to 6 cycles of treatment in the induction phase. Overall, the PFS predicted by the AG for R-CHOP is broadly similar to the PFS reported in Rummel *et al.* (Figure 26).⁷⁵

Figure 26: Comparison of the PFS from Rummel *et al.*⁷⁵ and predicted using the AG method.

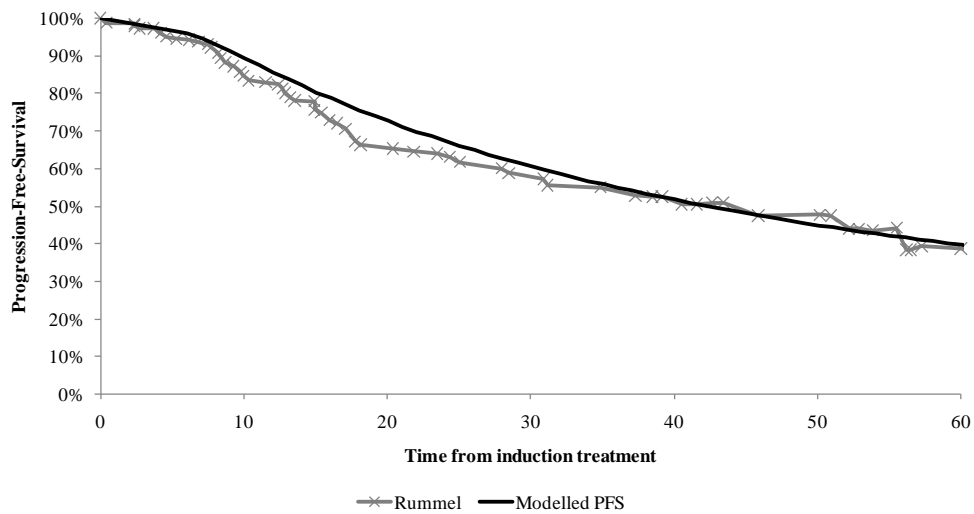

Effectiveness in patients treated with MCP with or without rituximab in first-line

As with CHOP containing regimens, data from the first-line trial for R-MCP and MCP⁹² are confounded by responders receiving subsequent maintenance therapy with interferon- α . No robust alternative sources were identified by the AG.

To provide an estimation of the cost-effectiveness of rituximab in addition to MCP, a scenario analysis is presented assuming that the PFS for responders and non-responders treated with MCP with or without rituximab are identical to the PFS in patients treated with CVP/CHOP with or without rituximab.

It is commented that whilst the PFS for responders and non-responders are assumed equal for R-CVP, R-CHOP and R-MCP and are assumed equal for CVP, CHOP and MCP, the differences in response rates (see Table 36), number of cycles and time between cycles (see Table 42) result in different prognoses between interventions (see Figure 27).

Summary of modelled PFS in first-line induction

The modelled combined PFS (including both responders and non-responders) for patients treated with CVP, CHOP and MCP with or without rituximab is presented in Figure 27.

Figure 27: PFS for all patients treated with CVP, CHOP and MCP with or without rituximab

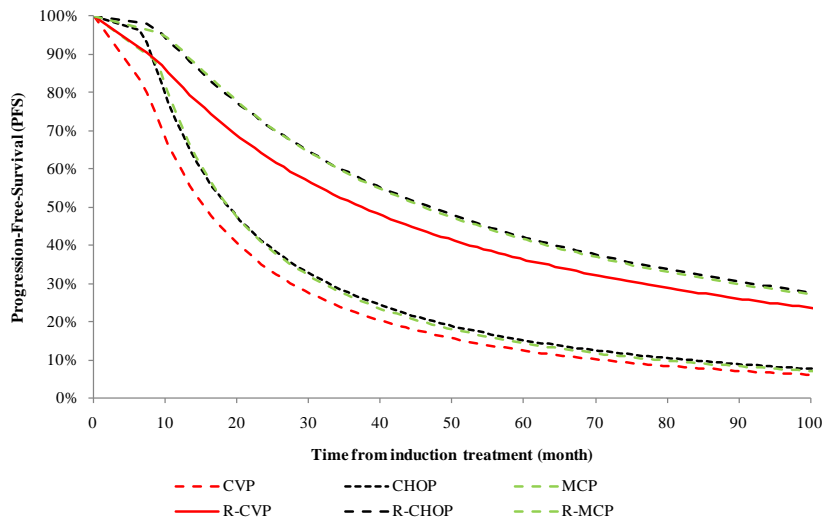

Effectiveness of rituximab first-line maintenance for patients that respond to first-line induction with chemotherapy in combination with rituximab (scenario analysis)

First-line maintenance was incorporated into the economic model by altering the risk of progression for patients responding to first-line induction with R-chemotherapy. The hazard ratio from the PRIMA study⁶⁹ was used to alter the risk of progression (observation vs. maintenance). While there were differences in the HR for patients treated with R-CHOP (HR 0.51; 0.39 – 0.65) and R-CVP (HR 0.68; 0.45 – 1.02), we used data for the whole randomised population as differences might have been attributable to small sample sizes. Consequently, a hazard ratio of 0.55 (CI: 0.44 – 0.68) was applied to the rate of progression for responders to R-chemotherapy for the first 42 months as clinical opinion suggests that the lasting effect ranges between 36 to 48 months.¹²⁸ Sensitivity analyses are conducted varying the lasting effect of first-line maintenance rituximab between 36 to 72 months.

Response rates in patients receiving second-line chemotherapy

The response rates for patients treated with CHOP and R-CHOP second-line induction treatment were extracted from the EORTC 20981 trial (Table 39).^{71,72} The response rates were not available for FC containing regimens used in older patients. As FC containing regimens are less aggressive therapies, a lower effectiveness is expected. In the absence of evidence, we arbitrarily assumed that FC is 20% less effective than CHOP. Sensitivity analyses were conducted varying the response rates for patients treated with FC with or without rituximab.

Table 39: Response rates among patients receiving second-line induction treatment^{90,91}

Second-line	CHOP ^{90,91}	R-CHOP ^{90,91}	FC	R-FC
Total number of patients	231	234	No data	No data
Nb of responders	145	189	No data	No data
Response rate	62.77%	80.77%	50.22% ^a	64.62% ^a

^a Assumed to be 20% lower compared to CHOP, R-CHOP

Effectiveness in patients treated with CHOP with or without rituximab in second-line

Data from the EORTC 20981 trial^{72,71} were used to model the PFS in FL patients treated with CHOP and R-CHOP in second-line induction, with or without rituximab maintenance. Patients were included in the EORTC 20981 trial^{72,71} if they had relapsed but had no more than two previous non-anthracycline-containing chemotherapy regimens. The study was conducted before the introduction of rituximab and therefore patients are rituximab naive, i.e. not previously exposed to rituximab. The initial results of the EORTC 20981 trial⁷² were updated in a second publication⁷¹ that included 6 years follow-up data. Patients were randomised to second-line induction treatment with either CHOP or R-CHOP, those patients who achieved a CR or PR had a second randomisation to either maintenance treatment with rituximab (once every 3 months) or observation for 2 years or until relapse.

Where possible, data from the latest follow-up duration⁷¹ were used in the economic model. The PFS and OS curves for responders to CHOP and R-CHOP second-line induction treatment were extracted from the latest follow-up of the EORTC 20981 trial.⁷¹ However, the PFS and OS curves for non-responders to treatment induction were extracted from data presented by the manufacturer in a previous submission to NICE.⁷⁰

Van Oers *et al.*⁷¹ only reported OS data for all responders regardless of whether treatment induction was CHOP or R-CHOP randomised to either maintenance treatment with rituximab or observation. Data by treatment induction have been presented by the manufacturer in a previous NICE appraisal,⁷⁰ however this used a shorter follow-up duration (median = 39.4 months from first randomisation). These data indicated that the OS curves for patients randomised to observation or maintenance rituximab were broadly similar whether patients received CHOP or R-CHOP in second-line treatment induction (see Figure 10 in MS for TA 137). In the economic model, it was assumed that the OS for patients treated with CHOP or R-CHOP was the same, although patients receiving observation did less well than those who had maintenance with rituximab.

The PFS and OS for responders using the latest follow-up data from the EORTC 20981⁷¹ are presented from second randomisation, i.e. from the end of treatment induction. Consequently, the risk of PFS and OS are assumed to be zero during treatment induction in the economic model. A summary of data used in the economic model is presented in Table 40.

It was not possible to have access to individual patient level data from the EORTC 20981 trial,^{72,71} and therefore only data available in the public domain were used.

Table 40: Summary of data from the EORTC 20981 trial^{71,70}

		PFS		OS	
		First randomisation	Second randomisation	First randomisation	Second randomisation
Non-responders	CHOP	✓ TA 137 ⁷⁰		✓ TA 137 ⁷⁰	
	R-CHOP	✓ TA 137 ⁷⁰		✓ TA 137 ⁷⁰	
Responders	CHOP – Observation		✓ Van Oers et al. ⁷¹		✓ Combined observation arm Van Oers et al. ⁷¹
	R-CHOP - Observation		✓ Van Oers et al. ⁷¹		
	CHOP – Maintenance		✓ Van Oers et al. ⁷¹		✓ Combined maintenance arm Van Oers et al. ⁷¹
	R-CHOP - Maintenance		✓ Van Oers et al. ⁷¹		

The digitised KM curves included in the MS⁶¹ were used to fit several parametric distributions to represent the risk of progression or the risk to death. In the absence of individual patient level data, the distributions have been fitted using the Solver function within MS Excel[®] in order to find the parameter values that minimise the root mean square error (RMSE) between the observed and predicted KM. The best distribution was selected using an iterative approach after analysing the visual plot of the curve, the hazard plot and the RMSE. Overall, the Weibull and Exponential distributions provided the poorest fit to the data. The Gompertz and Log-logistic distribution provided a reasonable fit to only part of the data. The Log-normal distribution fitted all the data reasonably well.

The plot of the PFS KM and predicted Log-normal distribution for patients responding to second-line treatment induction with CHOP and R-CHOP are presented in Figure 28 and 29.

Figure 28: Plot of the KM and Log-normal for patients responding to CHOP second-line induction (from the end of treatment induction) with or without maintenance rituximab.^{71,61}

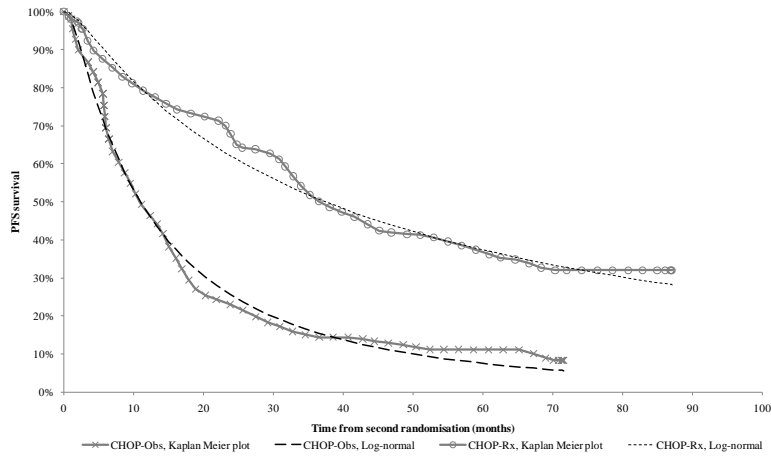

Obs = Observation ; Rx = maintenance rituximab

Figure 29: Plot of the KM and Log-normal for patients responding to R-CHOP second-line induction (from the end of treatment induction) with or without maintenance rituximab.^{71,61}

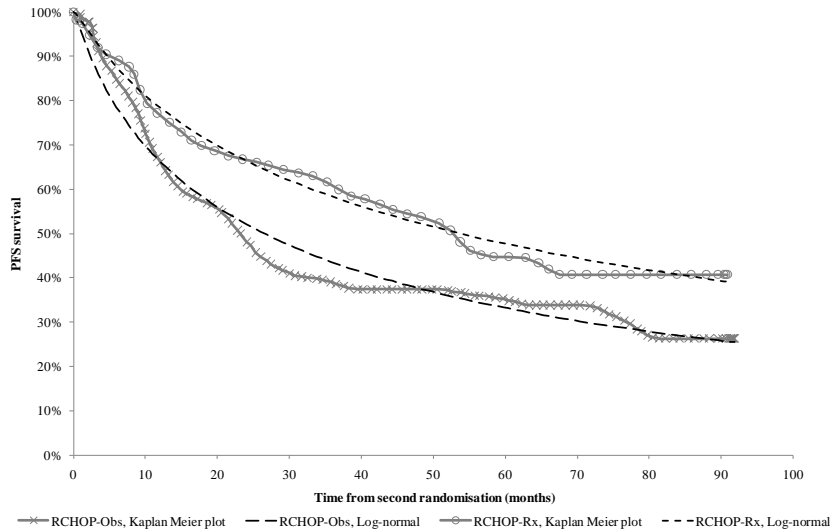

Obs = Observation ; Rx = maintenance rituximab

The plot of the OS KM and Log-normal distribution for patients responding to second-line treatment induction is presented in Figure 30.

Figure 30: Plot of the OS KM and Log-normal for responders to second-line induction (from end of treatment induction) with or without maintenance rituximab^{71,61}

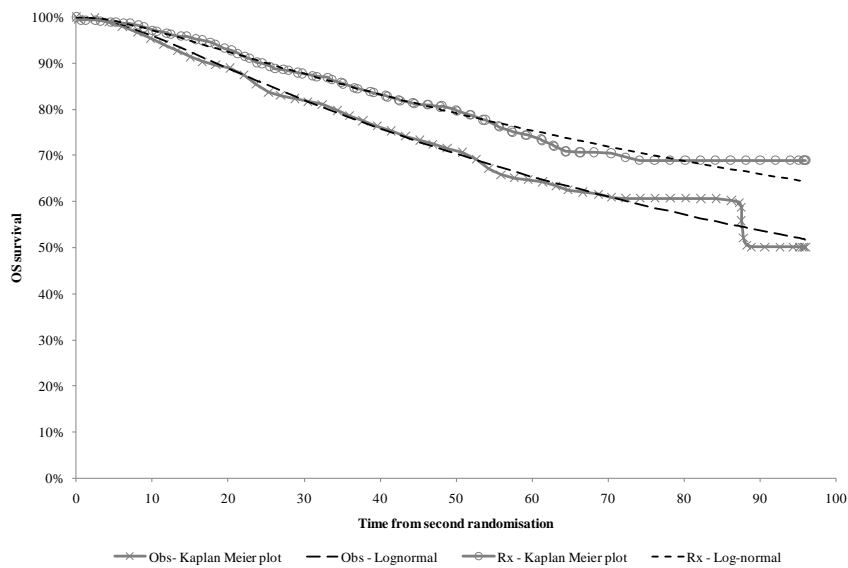

Obs = Observation ; Rx = maintenance rituximab

Finally the plot of the OS and PFS KM for non-responders to CHOP and R-CHOP in second-line treatment is presented in Figure 31.

Figure 31: Plot of the OS and PFS KM and Log-normal for non-responders to second-line induction treatment (from start of induction treatment)⁷⁰

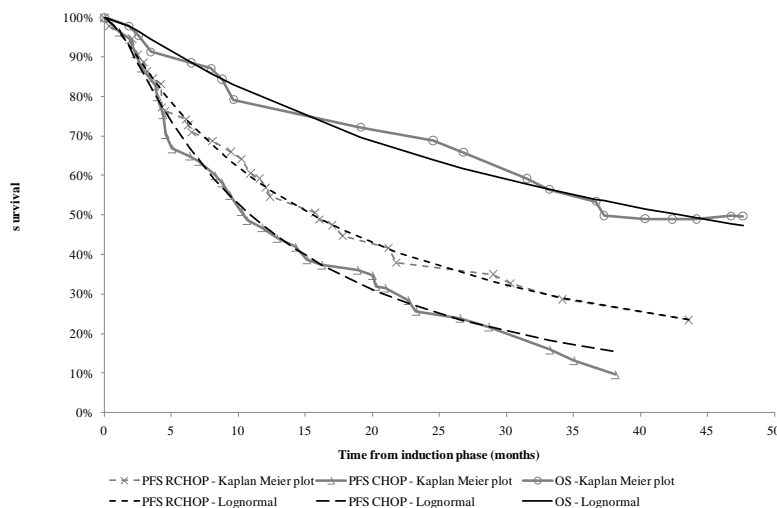

However, the distribution that provided the best fit to the data (the Log-normal) hampered uncertainty analysis. In the PSA, we varied the mean PFS and OS by $\pm 5\%$ by changing the mean parameter of the Log-normal distribution but assuming the same standard deviation. PFS and OS curves were sampled independently; however the same random number was used to preserve the correlation between OS and PFS.

Effectiveness in patients treated with FC in combination or not with rituximab in second-line treatment

Clinical opinion sought by the AG suggested that FC or R-FC would be used for patients that cannot tolerate aggressive therapy (such as CHOP or HDT with or without ASCT), in particular older patients.

The published literature was searched for potential sources to estimate the effectiveness of FC containing regimens with or without rituximab in relapsed FL patients aged over 65 years, however no data were identified. The AG was aware of a trial conducted in second-line treatment that compared fludarabine, cyclophosphamide, mitoxantrone (FCM) versus R-FCM¹⁴⁰ with or without maintenance rituximab. The median age of patients randomised to FCM or R-FCM was approximately 60 years. This trial also had a different maintenance schedule compared to that of Van Oers *et al.*^{72,71} which compared CHOP versus R-CHOP in second-line induction. A previous NICE technology appraisal⁷⁰ reported that the data were not mature in the R-FCM vs. FCM trial, but despite this limitation, the outcomes for R-FCM and R-CHOP are broadly similar.

The PFS and OS curves for responders and non-responders to CHOP and R-CHOP^{70,72,71} in second-line (see section about the effectiveness of CHOP and R-CHOP in second-line in p.139-142) have been used a proxy for the risk of progression for patients treated with FC and R-FC. However, because we assumed a lower response rate for FC containing regimen (20% lower) and the shorter induction period for FC/R-FC (4 cycles instead of 6), the overall modelled effectiveness for FC containing regimens will be reduced compared to CHOP containing regimens. Sensitivity analyses were conducted varying both the response rate and PFS curves (Appendix 15).

Effectiveness in patients receiving salvage therapy with HDT with or without rituximab and ASCT in relapsed FL patients

Clinical advice sought by the AG indicated that patients previously treated with an anthracycline containing regimen (CHOP, MCP) would not be re-treated with an anthracycline regimen and would likely receive salvage therapy with HDT with or without rituximab before ASCT in case for those that respond to chemotherapy.

Discussion with clinical experts suggested that the most commonly used HDT are up to 4 cycles of ESHAP (etoposide, methylprednisolone, cytarabine, cisplatin) or DHAP (dexamethasone, cytarabine, cisplatin) chemotherapy with or without rituximab. Stem cell harvest is then obtained for responders only, with patients for whom the harvest was successful eligible for BEAM (BCNU [carmustine], cytarabine, etoposide, melphalan) conditioning plus ASCT (Figure 32).

Figure 32: Treatment pathway for patients treated with HDT with or without rituximab

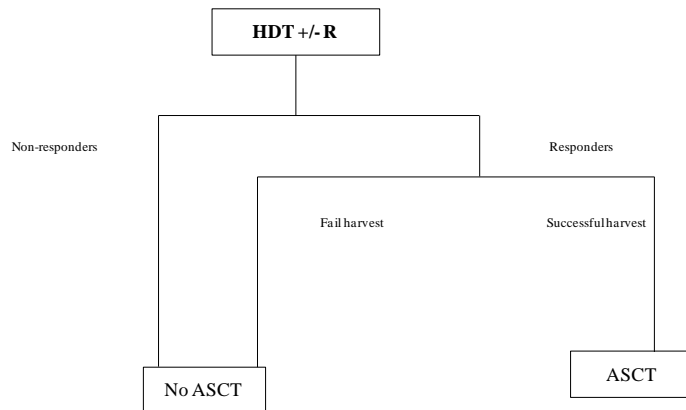

The literature was searched to identify studies that reported the impact of the addition of rituximab to salvage therapy before ASCT in relapsed FL patients, although given the resource constraints it was not possible to perform a systematic search of the literature.

Sebban *et al.*¹³⁵ reported the impact of rituximab with or without HDT with transplant at the time of relapse in FL patients. This retrospective study included patients that received CHVP alone or in addition to interferon in first-line induction. Relapsed patients receive salvage therapies, with the most used regimens being demzamesthasone, high-dose cytarabine and cisplastin, ifosfamide, carboplatin and etoposide, mesna, ifosfamide, mitoxantrone and etoposide and fludarabine based regimens. Rituximab was also offered to a proportion of patients with or without chemotherapy as part of the salvage treatment. Sebban *et al.*¹³⁵ reported that the 5-year event free survival (EFSR) after first relapse was 52% in patients receiving rituximab as part of the salvage therapy (with or without chemotherapy) and 29% in patient receiving salvage therapy without rituximab. The 5-year survival after first relapse (SAR) rate was 81% and 44% respectively.

Clinical opinion was sought regarding the validity of using evidence from this study¹³⁵ to model the effectiveness of salvage therapy in addition to ASCT with or without rituximab. Overall, the clinical experts found the study appropriate, but cautioned that there were potential limitations in the study design. The addition of rituximab to salvage therapy is associated with considerable benefit although it is unclear if the magnitude of the observed improvement is due to the retrospective nature of the study.¹³⁵ The study was also conducted in a pre-rituximab era, and therefore patients were not previously exposed to rituximab. It is also unclear from the study the proportion of patients that responded to HDT, for whom the harvest was successful and the proportion of patients that received ASCT in both arms.

Despite these potential limitations, data from Sebban *et al.*¹³⁵ were used in the economic model to represent the effectiveness of salvage therapy with or without rituximab. Data for EFSR and SAR after salvage therapy with or without rituximab were taken from Figure 3 in Sebban *et al.*¹³⁵ Techdig[®] software was used to estimate the data points and allow parametric distributions to be fitted. We examined different distributions using the Solver function within MS Excel[®] and overall, the Log-normal was found to provide the best fit to the data. The plot of the KM and estimated Log-normal is presented in Figure 33 for EFS and Figure 34 for OS.

Figure 33: EFS for patients treated with ASCT and salvage chemotherapy with or without rituximab¹³⁵

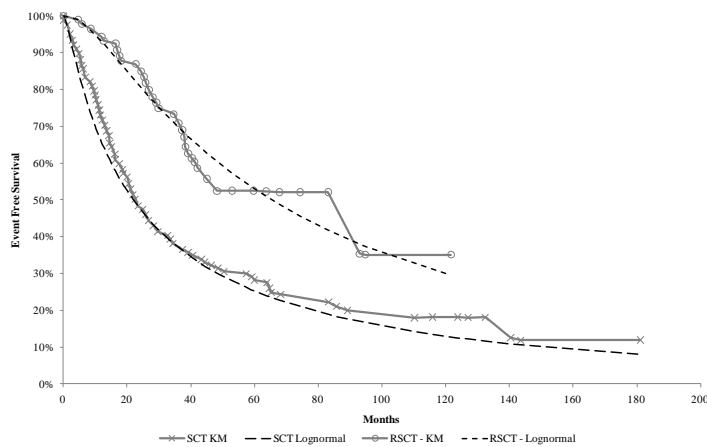
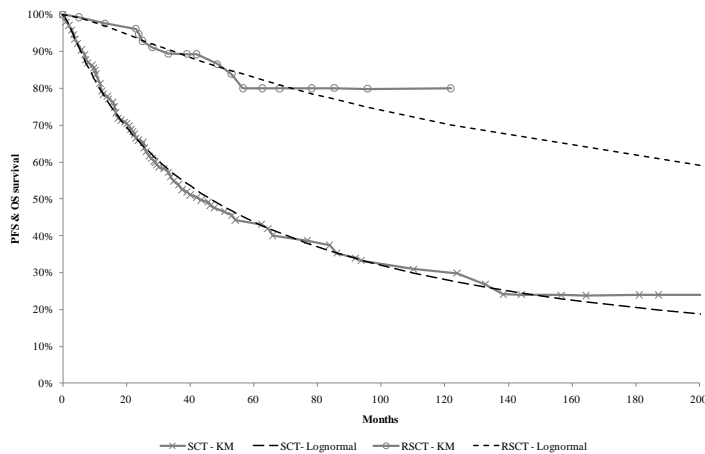

Figure 34: OS for patients treated with ASCT and salvage chemotherapy with or without rituximab¹³⁵



The mean effectiveness was varied by $\pm 5\%$ in the PSA, with the standard deviation of the log-normal distribution assumed constant.

Resistance to rituximab in patients previously exposed to rituximab treatment

A key assumption of the economic model submitted by the manufacturer is the absence of resistance in patients previously treated with rituximab

Evidence of resistance in relapsed FL patients have been estimated in cohorts of patients that have not been previously exposed to rituximab, although clinical opinion expressed in a previous NICE appraisal of rituximab⁷⁰ suggested that there might be little or no loss of efficacy for re-treatment with rituximab, given its mechanism of action. In the MS⁶¹ two studies are referenced to support the assumption of the absence of a resistance effect to rituximab.^{129,130} However, the AG does not believe that the data from these two studies provide conclusive evidence that resistance to rituximab can be discounted.

Johnston *et al.*¹²⁹ report that second-line response rates were only marginally reduced in FL patients when compared with first-line response rates (ORR 88% to 76%; CR 52% to 44% and PR 36% to 32% in first-line and second-line respectively). However, a comparison between patients who had received chemotherapy alone in first- and second-line and patients who had received R-chemotherapy in first- and second-line, demonstrated that PFS following the second-line treatment was no different between the two patients groups, indicating that the second rituximab treatment had little benefit. There were several problems, however, with the study undertaken by Johnston *et al.*¹²⁹ in terms of its ability to prove or disprove resistance to rituximab. Firstly, the number of FL patients (n=50) was small and the patients were not representative of UK FL patients (median age at start of second treatment was young; 59 years). In addition, the comparisons being made were not ideal in determining the existence of rituximab resistance: R-chemotherapy (first-line) and R-chemotherapy (second-line) were compared with chemotherapy alone (first-line) and chemotherapy alone (second-line). The correct comparison would be R-chemotherapy (first-line) + R-chemotherapy (second-line) versus chemotherapy alone (first-line) and R-chemotherapy (second-line). A substantial number of patients were also receiving R-monotherapy which is not recommended in the UK unless all other options have been exhausted.

Coiffier *et al.*¹³⁰ presented results from a small sample of patients (n=59) who received one of the following combinations: R-monotherapy/R-monotherapy; R-chemotherapy/R-chemotherapy, R-monotherapy/R-chemotherapy; R-chemotherapy/R-monotherapy. The findings showed that the second-line response rate and time to progression did not appear to be affected by rituximab in patients who had received rituximab in first-line. However, the number of patients who received R-monotherapy is unknown and the participants in the study were patients diagnosed with a B-cell lymphoma, thus the numbers of FL patients within the study is unknown.

From a non systematic review of the literature via web-searching, the AG identified further studies conducted in other types of lymphoma suggesting that re-treatment with rituximab might be associated with a loss of efficacy.^{131,132,133}

Borgerding *et al.*¹³¹ reported a very low response rate in a cohort of 28 DLBCL patients after prior exposure to rituximab. The authors reported an overall response rate of 32% (9 of 28 patients). Furthermore, Weide *et al.*¹³³ examined the use of bendamustine in combination with mitoxantrone and rituximab (BMR) in patients with stage III/IV relapsed or refractory indolent lymphomas and mantle cell lymphoma (MCL) with or without prior rituximab containing chemo-immunotherapy treatment. Fifty-seven patients were recruited, 39% of whom had received prior R-chemo therapy. The median age was 66 years (range 40 – 83). Approximately 50% of patients had FL. The overall response rate (ORR) was 89% with 35% CR and 54% PR. ORR in R-chemo pre-treated patients was lower at 76% (38% CR, 38% PR).

Similarly, Martin *et al.*¹³² report a phase III trial comparing the response rates to R-ICE (ifosfamide, carboplatin, etoposide) and R-DHAP salvage therapy followed by high-dose therapy with autologous stem cell transplantation (CORAL trial) for patients with relapsed or refractory DLBCL. Martin *et al.*¹³² report that prior exposure to rituximab was associated with a significant loss of efficacy. Patients in the rituximab group had a significantly worse PFS (17% v 57% at 3 years) and OS (38% v 67% at 3 years) as compared to patients not previously treated with rituximab. Prior exposure to rituximab was an independent adverse prognostic factor for both PFS (RR: 2.0; 95% CI: 1.2-3.3; $p=0.008$) and OS (RR: 2.2; 95% CI: 1.3-3.9; $p=0.004$). The AG acknowledges that the effectiveness between patients previously treated with rituximab and those naive to rituximab might be confounded by the level of disease aggressiveness; those relapsing early on rituximab might have a more aggressive disease.

Overall, the two studies reported by the manufacturer do not provide conclusive evidence to prove or disprove rituximab resistance. Further studies identified by the AG^{131,132,133} suggest that there might be a resistance effect to rituximab. The AG sought clinical advice on this issue which indicated that resistance of rituximab is unknown, however the clinicians believed that there is little or no loss of effectiveness considering its mechanism of action.

In the base case, no resistance is assumed. Sensitivity analyses are conducted exploring the potential development of resistance after rituximab re-treatment. Sensitivity analyses are conducted by increasing the rate of progression in patients receiving rituximab in second-line when they had previously been treated with rituximab.

Incorporation of adverse events in the economic assessment

The economic model includes the impact of adverse events in terms of management costs and impairment in quality of life. Only grade 3 and 4 adverse events were included as these are deemed of clinical and economic importance by the AG. Furthermore, only those that occurred in the first-line induction setting were included due the lack of robust data in patients treated in second-line and subsequent lines of treatment.

After reviewing the relative frequency of adverse events within patients treated with chemotherapy with and without rituximab and the likely management cost and impact on HRQoL, the AG included the following adverse events in first-line induction: leukopenia, granulocytopenia, neutropenia, anaemia, alopecia, infection, cardiac arrhythmia and cardiac dysfunction.

Only grade 3/4 neutropenia and leukopenia have been included in first-line maintenance as these were the most commonly reported grade 3 or 4 adverse events in the PRIMA study.⁶⁹

The management costs associated with the treatment of adverse events were extracted from the costs used in a submission by the manufacturer for an ongoing NICE appraisal.¹²⁵ It is also assumed that grade 3 and 4 adverse events would incur the same costs. We further assumed that each adverse event led to a reduction in HRQoL by 15% for 45 days. It was not possible to independently estimate the management costs of adverse events and the effect on HRQoL due to resource constraints. The management costs were varied by $\pm 20\%$ in sensitivity analyses. The disutility was also varied in sensitivity analyses.

The AG acknowledges the limitations of the inclusion of AE in the economic model in that it is very simplistic. However, sensitivity analyses presented later indicated that AE had a limited impact on the ICER (Appendix 15). Table 41 provides a summary of adverse events included in the economic model.

Table 41: The rates of adverse events and management costs used in the economic model

Adverse event	CVP^{94,95}	R-CVP^{94,95}	CHOP⁹¹	R-CHOP⁹¹	MCP⁹²	R-MCP⁹²	Cost used in the economic model	Source for costs
Leukopenia	8.81%	11.73%	60.98%	69.06%	58.33%	71.43%	£0	MS for ongoing NICE appraisal ¹²⁵
Granulocytopenia	-	-	53.17%	63.06%	-	-	£1,514	MS for ongoing NICE appraisal ¹²⁵
Neutropenia	13.84%	24.07%	-	-	-	-	£3,272	MS for ongoing NICE appraisal ¹²⁵
Anaemia	-	-	10.24%	8.97%	4.17%	2.86%	£ 445	SA09F: Other Red Blood Cell Disorders without CC ¹⁴¹
Alopecia	-	-	60.98%	66.82%	-	-	£44	MS for ongoing NICE appraisal; assumed to be the same as depression ¹²⁵
Infection	-	-	6.83%	4.95%	8.33%	6.67%	£1,077	MS for ongoing NICE appraisal ¹²⁵
Cardiac dysfunction	-	-	0.98%	3.14%	-	-	£606	MS for ongoing NICE appraisal; assumed to be the same as arrhythmia ¹²⁵
Cardiac arrhythmia	-	-	0.00%	1.79%	-	-	£606	MS for ongoing NICE appraisal ¹²⁵

Drug acquisition and administration costs

The planned dose from the three main trials^{94,95,91,92} were used to calculate the drug acquisition cost in the absence of detailed information about dose reduction/increase for each separate arms in the trials.

The planned number of cycles were also used in the economic model. Patients treated with CHOP or R-CHOP were assumed to receive a maximum of 8 cycles in first-line induction and 6 cycles in second-line induction. A sensitivity analysis was conducted assuming that patients received a maximum of 6 cycles of CHOP and R-CHOP in first-line induction. Patients treated with FC or R-FC were assumed to receive a maximum of 4 cycles in second-line induction. A sensitivity analysis was conducted assuming that patients treated with FC containing regimens would receive a maximum of 6 cycles. The planned dose and maximum number of cycles used in the economic model are summarised in Table 42.

In the economic model, the number of cycles a patient receives is calculated from the PFS curve to account for patients that withdraw before the end of planned treatment due to progression. Withdrawal from toxicity was not modelled; however this was shown to be uncommon in the first-line trials.^{94,95,90,91,92}

The acquisition costs of the intervention are calculated from the protocol defined/planned dose, the BSA (Table 35) and unit costs extracted from the British National Formulary (BNF).⁸⁴ No vial sharing is assumed.

Table 42: Dose and number of cycle used in the economic model

	CVP^{94,95}	R-CVP^{94,95}	CHOP⁹¹	R-CHOP⁹¹	MCP⁹²	R-MCP⁹²
Cyclophosphamide	750mg/m ² IV day 1	750mg/m ² IV day 1	750mg/m ² IV day 1	750mg/m ² IV day 1		
Vincristine	1.4mg/m ² IV day 1	1.4mg/m ² IV day 1	1.4mg/m ² IV day 1	1.4mg/m ² IV day 1		
Prednisone/Prednisolone ^a	40mg/m ² days 1-5	40mg/m ² days 1-5	100mg/m ² days 1-5	100mg/m ² days 1-5	25mg/m ² days 1-5	25mg/m ² days 1-5
Mitoxantrone					8mg/m ² IV days 1 and 2	8mg/m ² IV days 1 and 2
Chlorambucil					3*3mg/m ² orally days 1-5	3*3mg/m ² orally days 1-5
Doxorubicin			50mg/m ² IV day 1	50mg/m ² IV day 1		
Rituximab		375mg/m ² IV day 1		375mg/m ² IV day 1		375mg/m ² IV day 1
Maximum number of cycles	8	8	6-8 ^b	6-8 ^b	8	8
Interval between cycles	21	21	21	21	28	28

^a Prednisone is assumed to be similar to prednisolone; ^b Assuming 8 cycles in the economic model in first-line and 6 cycles in second-line induction IV=intravenously

The costs associated with the administration of each cycle of treatment are derived from NHS reference costs 2009/2010¹⁴¹ and assumptions included in the MS.⁶¹ Chemotherapies are assumed to be administered on a day-case basis. The unit costs and HRG used are presented in Table 43. In addition to the administration costs from the NHS reference costs, patients who receive rituximab are assumed to incur additional pharmacy costs based on the costs included in the MS (£15.54).⁶¹ A sensitivity analysis is conducted assuming a cost of £32 as used by the manufacturer in an ongoing NICE appraisal for maintenance rituximab.¹²⁵ Finally, the cost associated with transport is also included assuming that 30% of patients require NHS transportation.⁶¹

Table 43: Drug administration costs

Regimen	Administration cost	Source
R-Chemotherapy	£309.17	SB14Z: Deliver complex Chemotherapy, including prolonged infusional treatment at first attendance ¹⁴¹
Maintenance	£284.45	SB15Z: Deliver subsequent elements of a Chemotherapy cycle ¹⁴¹
Chemotherapy alone	£270.62	SB13Z: Deliver more complex Parenteral Chemotherapy at first attendance ¹⁴¹
Pharmacy cost	£15.54	MS ⁶¹
Transport	£39.24	PTS: Patient Transport Services ¹⁴¹

A summary of drug acquisition and administration costs by chemotherapy cycle in first-line induction per patient is presented in Table 44 assuming a BSA of 1.80.

Table 44: Drug acquisition and administration costs by chemotherapy cycle per patient in first-line induction

	CVP	R-CVP	CHOP	R-CHOP	MCP	R-MCP
Drug acquisition cost / cycle	£60.48	£1,282.89	£233.08	£1,455.49	£218.78	£1,441.19
Administration cost / cycle	£297.93	£336.49	£297.93	£336.49	£568.55	£607.10
Total treatment cost/cycle	£358.41	£1,619.38	£531.01	£1,791.98	£787.33	£2,048.29
Total treatment cost / patient according to the protocol defined dose	£2,867	£12,955	£4,248	£14,336	£6,299	£16,386

^a Assuming 2 days of administration

It is not clear from Sebban *et al.*¹³⁵ which salvage therapies or which rituximab regimens was used. It is also unclear what were the proportion of patients that responded to salvage therapy, the proportion that had a successful harvest and the proportion of patients that receive ASCT.

In the economic model, we assumed that patients receive 2 cycles of ESHAP with or without rituximab before ASCT with BEAM. The planned dose has been extracted from the clinical policies and protocol document from Surrey, West Sussex and Hampshire Cancer Network¹⁴² presented in Table 45. We assumed that rituximab is administered at 375mg/m². The cost of salvage therapy with or without rituximab in relapsed FL patients is estimated from the BNF⁸⁴

Table 45: Treatment protocol for ESHAP¹⁴²

Day	Drug	Dose
1 – 4 (4 doses)	Cisplatin	25mg/m ² /day
1 – 5 (5 doses)	Methylprednisolone	500mg/day
1 ONLY	Cytarabine	2000mg/m ²
1 – 4 (4 doses)	Etoposide	40mg/m ² /day
1 – 6 (6 doses)	Corticosteroid eye drops e.g. prednisolone 0.5%	One drop

In the base case, we assumed the response rates for HDT with or without rituximab to be 10% higher compared to the response rates for CHOP and R-CHOP in second-line treatment.^{72,71} We further assumed that 80% of patients have a successful harvest after response to HDT. The AG stresses that these assumptions have been made with extremely limited supportive data. Sensitivity analyses were conducted varying both the response rate for HDT and proportion of patients with successful harvest.

For patients responding to HDT with or without rituximab and for whom the harvest was successful, the cost of ASCT+BEAM was assumed to be £30,400 based on a costing exercise commissioned by the London Specialised Commissioning Group.¹⁴³ The cost includes pre-transplant mobilisation, stem cell harvest and storage, pre-transplant assessment, patient work up, transplant admission and cost up to 1 year after discharge.

Management at the end of treatment induction/maintenance; monitoring and surveillance cost

The management of the disease at the end of treatment induction and/or maintenance is adapted from the monitoring reported in the MS⁶¹ after discussion with our clinical experts. Compared to the monitoring reported in the MS,⁶¹ the monitoring defined by our clinical experts (Table 46) was less intensive, particularly with regard to scanning and imaging.

The AG comments that the monitoring used in the economic model is simplistic, but that sensitivity analyses indicated that the results were not markedly influenced by this parameter (Appendix 15).

After first- and second-line induction treatment the monitoring was separated into two phases;

- First six months after the end of treatment induction
- Remaining months

The monitoring after maintenance treatment with rituximab has also been separated into two phases;

- First 24 months after the end of maintenance
- Remaining months

Unit costs have been extracted from the NHS reference cost 2009/2010 and costs used in the Sheffield Teaching Hospital Trust (Personal communication, 2005-2006). Costs are summarised in Table 47.

Table 46: Monitoring and management at the end of treatment induction/maintenance

Items	Frequency	
	Treatment induction	Maintenance
Period 1	First 6 months after end of treatment induction	First 24 months after end of maintenance
Haematologist led	1 every month	1 every 3 months
computerised tomography (CT) scans	1 CT scan at end of treatment	1 CT scan at end of treatment
Full Blood Count (FBC), patient history, physical exam, Liver Function Test (LFT), Urea and electrolytes (U&E)	1 every month	1 every 3 months
Period 2	Remaining months	Remaining months
Haematologist led	1 every 4 months	1 every 4 months
CT scans	No CT scan	No CT scan
FBC, patient history, physical exam	1 every 4 months	1 every 4 months
Immunoglobulin tests, LFT, U & E lactate dehydrogenase.	1 every 4 month	1 every 4 month

Table 47: Unit costs applied to estimate monitoring cost

Resource	Unit cost £	Definition/Source
Hospital clinic visit with haematologist	128.67	Code: 303 – Clinical haematology Consultant Led: Follow up Attendance Non-Admitted Face to Face. ¹⁴¹
CT Scan	146.16	Code: RA14Z – CT scan, more than 3 areas. ¹⁴¹
Full blood count	5.50	Sheffield hospital (Sheffield Teaching Hospital Trust, Personal communication, 2005–6)
Patient history/physical exam	5.44	Code: DAP842-Other pathology service ¹⁴¹
Full profile (U&E, LFT, Ca)	14.98	Sheffield hospital (Sheffield Teaching Hospital Trust, Personal communication, 2005–6)
Serum IgG, IgA, IgM and electrophoresis	21.99	Sheffield hospital (Sheffield Teaching Hospital Trust, Personal communication, 2005–6)
Lactate dehydrogenate test	11.12	Sheffield hospital (Sheffield Teaching Hospital Trust, Personal communication, 2005–6)

Health service costs associated with management in third/subsequent lines

Patients that progress after second-line treatment with CHOP, R-CHOP, FC or R-FC (induction or maintenance) and who are still alive are assumed to undergo third/subsequent lines of therapy. A one-off cost was applied in the economic model according to the choice of treatment received in second-line (induction and maintenance).

The management costs were estimated from the post-protocol treatments observed in the EORTC 20981 trial.^{72,71} The frequency of resources used for patients treated with CHOP only, R-CHOP only, CHOP in addition to maintenance rituximab and R-CHOP in addition to maintenance rituximab⁷¹ were multiplied by the unit costs used by the manufacturer in a previous NICE appraisal (Table 48).⁷⁰ Unit were not inflated as main costs were drug and procedure costs.

Patients treated with HDT with or without rituximab are assumed to go directly onto palliative care and no costs were applied for the further lines of treatments. This assumption was made in the absence of data about the post-progression treatment after HDT with or without ASCT and the assumption that fewer treatments are available after

relapse to ASCT or HDT. A sensitivity analysis was conducted assuming no costs for third-line treatment for all patients.

Table 48: Post protocol treatment and mean cost associated with third/subsequent line of therapy according to the choice of second-line induction treatment/maintenance

Treatment receive in second-line⁷¹					
	Unit cost⁷⁰	CHOP	R-CHOP	CHOP - Rx^a	R-CHOP – Rx^a
Chemotherapy	£3,232	49.28%	33.67%	34.21%	38.46%
Radiotherapy	£1,620	23.19%	18.37%	17.11%	17.58%
Autologous SCT	£18,998	4.35%	8.16%	7.89%	5.49%
Allogenic SCT	£41,721	7.25%	7.14%	10.53%	4.40%
Rx, single	£8,490	37.68%	13.27%	10.53%	5.49%
Rx, comb	£11,206	28.99%	14.29%	17.11%	8.79%
Other	£0	11.59%	12.24%	7.89%	18.68%
Total cost		£ 12,265	£ 8,644	£ 10,085	£ 5,857

^a Rx: maintenance rituximab

Health service costs associated with palliative and/or terminal care

The costs associated with palliative care were estimated from the cost of palliative care for different type of advanced cancers (breast, colon, lung, uterus, ovary, prostate, stomach/oesophagus) from the start of strong opioid treatment until death.¹⁴⁴ The average cost per month was calculated excluding the cost of hospitalisation as it is likely that hospitalisation costs represent terminal care. The costs per month have been inflated to 2010 prices and are estimated to be £180.68 per month.

In addition to the cost of palliative care, the cost associated with terminal care, i.e. the management before death was included. This cost was only applied to patients for whom the cause of death is attributable to FL. The cost of terminal care is sourced from the NICE clinical guidance on cancer palliative/supportive care¹²⁶ and includes the cost of support provided by specialist hospital/community palliative care teams, including hospice type care, day care, hospital inpatient/outpatient support, bereavement services and continuous support for dying patients. The cost per cancer death is assumed to be £4,077 (£3,236 inflated to 2010).¹²⁶

The AG acknowledges that it is possible that there might be double-counting as two separate sources have been used. Sensitivity analyses were conducted assuming no cost for terminal care.

Death in PFS1

We used PFS as a proxy for progression, however, PFS includes both relapse and death as an event. The MS⁶¹ reported that 7 deaths occurred in the CVP arm and 3 deaths in the R-CVP arm. At the end of the trial follow-up period, it was estimated that the number of events (death and/or progression) were 136 and 98 respectively based on the KM curves and number of patients randomised. Consequently, we estimated that 5.15% (CVP) and 3.06% (R-CVP) of progression events were attributable to death. The rate of death in CVP was applied to CHOP and MCP. The rate of death in R-CVP was applied to R-CHOP and R-MCP. The rate is then varied using a beta distribution in the PSA.

Health state utilities

This section of the report presents a systematic review of health state utilities in FL patients and describes the assignment of utilities in the economic model.

Systematic review of health state utilities in FL patients

Methods

A systematic search was performed to identify studies addressing the impairment in quality of life in patients with FL. Full papers and abstracts were included in the review. Only studies conducted in patients with FL or studies conducted in a mix of similar patients when the majority of patients had FL have been included. As the AG was aware of data using the EQ-5D in FL patients and given resource constraints, only studies assessing the quality of life using the EQ-5D have been considered for the review as this is the preferred valuation method of HRQoL by NICE.⁹⁶ The AG acknowledges that this may be a limitation.

The following databases were searched for relevant published literature: MEDLINE including Medline in process (Ovid); CINAHL; EMBASE; The Cochrane Library including the Cochrane Database of Systematic Reviews, Cochrane Controlled Trials Register (CENTRAL), DARE, NHS EED and HTA databases; Science Citation Index (SCI); BIOSIS. Ongoing research have been searched using clinical trials databases and registers including: NIHR Clinical Research Network Portfolio; National Research Register (NRR) archive 2000-2007; Current Controlled Trials and Clinical Trials.gov. Finally, relevant conference proceedings were searched, including the American Society of Clinical Oncology (ASCO), European Society of Clinical Oncology (ESCO), American Society of Hematology (ASH), the British Society for Haematology (BSH) and the European Hematology Association (EHA). Full details of the main search strategy for this review are presented in Appendix 5. In addition, the MS was handsearched⁶¹ to indentify relevant references.

Studies were selected for inclusion through a two-stage process. Titles and abstracts were examined for inclusion by one reviewer. Full manuscripts of selected citations have been retrieved and assessed by one reviewer.

Results

Identified studies

The search retrieved 712 citations relating to quality of life (Figure 35). Six hundred and sixty-nine articles were excluded at title stage, and 28 articles were excluded at abstract level. Fifteen studies have been examined at full-text level and two studies (corresponding to three references) were identified meeting the criteria for the systematic review of quality of life data. The study conducted by Wild *et al.*^{119,120} is unpublished and was commissioned by the manufacturer. The full report was made available to the AG and is referred as the “Oxford Outcome study”. The second study, by Friedlich *et al.*¹⁴⁵ was only available in the abstract form and was conducted in a mix of patients with follicular and other indolent lymphomas. A summary of included studies is below. Reasons for exclusion were the absence of EQ-5D data (use of other instruments or EQ-5D data not presented), Q-twist analysis or utilities estimated in a different population.

Figure 35: Flow diagram of Quality of life review selection/exclusion

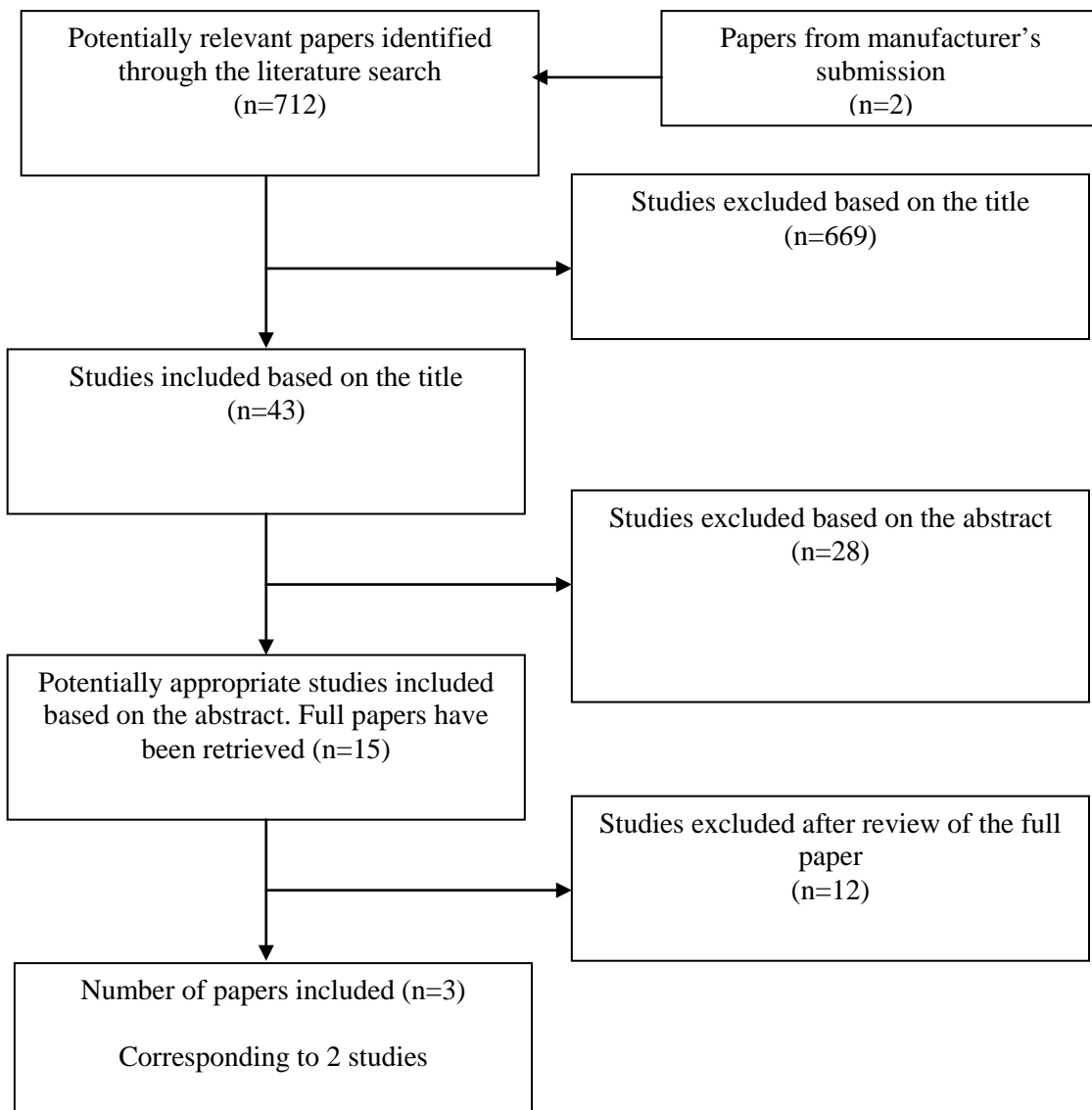

Review of the Oxford Outcomes Study^{120,119}

The review is based on the unpublished report of the study¹²⁰ made available to the AG by the manufacturer. This study was commissioned by the manufacturer and was used in their economic model.

Method

The study included 222 patients, aged 18 years or older with histologically confirmed FL and an ECOG performance status of 0 to 2. Patients were recruited from eight UK sites. Utilities were elicited from patients using the ED-5D questionnaire. The Visual Analogue Scale (VAS) score is also presented. Patients also completed other outcome measures such as the Functional Assessment of Cancer Therapy–G (FACT) and FACT-LYM (lymphoma).

Of the 222 returned case report forms, 215 participants returned completed EQ-5D questionnaires and 218 returned completed VAS data. The main analysis separated patients into five possible health states (HS):

- Active disease: newly diagnosed (HS1)
- Active disease relapsed (HS2)
- Partial response to therapy (HS3)
- Complete response to therapy/remission (HS4)
- Disease free (no detectable diseases) (HS5)

The authors state that *“four of the five categories relate to the known stage of the disease and in particular to patients response to treatment. Patients who are disease free have essentially had the best response to treatment, those in remission the next, followed by partial response and finally those without response (or whose response has relapsed). The newly diagnosed stage represents patients who have active disease and have started (or may be about to start) treatment, but for whom their response to treatment and therefore the relevant response categorisation is unknown”*.

Additional analyses are also presented aggregating the following health states:

- “Partial response to therapy” (HS3), “Complete response to therapy/remission” (HS4), “Disease free” (no detectable diseases) (HS5)
- “Active disease: newly diagnosed” (HS1), “Active disease relapsed” (HS2)

Differences in the health states utilities between groups have been examined using the Kruskal-Wallis H-test or Mann-Whitney test. Analyses are also presented estimating health state utility using ordinary least-square regression analysis. The study also examined the impact of current and previous treatment with chemotherapy, but was not powered to examine this issue.

Results

Health states utilities for the five health states defined in the main analysis are presented in Table 49.

Table 49: Health state utilities presented in the main analysis with patients assigned to five possible health states^{120,119}

Disease state	N	Mean (SD)/(SE)	Range	
			Minimum	Maximum
Active disease – Newly diagnosed (HS1)	50	0.83 (0.22)[0.03]	-0.24	1.00
Active disease – Relapsed	33	0.62 (0.32)[0.06]	-0.08	1.00
Partial response to therapy (HS3)	39	0.77 (0.21)[0.03]	0.02	1.00
Remission/Full response to therapy (HS4)	66	0.79 (0.23)[0.03]	-0.08	1.00
Disease free (HS5)	27	0.88 (0.15)[0.03]	0.49	1.00

SD= standard deviation; SE= standard error

Additional analyses aggregating health states are presented in Table 50.

Table 50: Aggregation of health state utilities^{120,119}

Health state	N	Mean	Standard error
Pre-progression (HS3, HS4, HS5)	132	0.805	0.018
Disease Progression (HS1, HS2)	84	0.7363	NR
Progression-free (HS3, HS4, HS5) ^a	134	0.7699	NR

^a It is unclear how this was calculated, there appears to be an error as 134 does not equal to 39+66+27 (see Table 49) NR= not reported

Comments

The definition of selected health states is poorly described. Following the short description provided by the authors, it appears that the health states relate to the degree of response to chemotherapy but not the number of previous lines of chemotherapy (Table 51). Forty-two percent of patients achieving partial response to therapy received two or more chemotherapies; the proportion of patients in remission/full response to therapy that received two or more previous chemotherapy is about 28%.

Table 51: Number of patients in each disease state that have received from 0 to 6 previous treatments^{120,119}

Number of previous chemotherapies	Disease state				
	Active disease – Newly diagnosed (n = 51)	Active disease – Relapsed (n = 34)	Partial response to therapy (n = 40)	Remission/Full response to therapy (n = 67)	Disease free (n = 26)
0	94.1%	20.6%	10.0%	22.4%	11.5%
1	2.0%	17.6%	47.5%	49.3%	30.8%
2	2.0%	20.6%	20.0%	13.4%	23.1%
3	2.0%	26.5%	5.0%	6.0%	23.1%
4	0.0%	5.9%	7.5%	6.0%	3.8%
5	0.0%	8.8%	7.5%	3.0%	7.7%
6	0.0%	0.0%	2.5%	0.0%	0.0%

In the main analysis, where patients were separated into 5 possible health states, there are some concerns about the small sample size of patients included within each health states (range: 27 – 50). Inaccuracy could be easily introduced when working with such small sample sizes. The description of included patients is also poorly detailed within the report, but is available in a related publication.¹⁴⁶ Thirty-three percent of patients had stage I/II FL. Utility values are expected to be lower where only FL patients with stage III/IV are included. Finally, there are some inconsistencies between the sub-group analyses (Table 50) when health states were aggregated.

Review of Friedlich et al.¹⁴⁵

Only the abstract form of the study¹⁴⁵ was available. The study was conducted in patients with indolent lymphoma or FL attending an outpatient malignant haematology clinic in Toronto (Canada). Patients were asked to complete a questionnaire including utility measures (EQ-5D, FACT).

Eighty-four patients completed the questionnaire. The mean age was 58.7 years (SD: 13.8) and 55% were male. The majority of patients had FL (55%). Similarly, the majority of patients had Stage III/IV (65%).

The mean utility score for the population was 0.84 ± 0.24 SD. The authors reported that utilities were higher ($p=0.049$) in patients being observed (0.91 ± 0.16 SD) compared to those in first remission (0.84 ± 0.25 SD), subsequent remissions (0.81 ± 0.20), or those who were receiving active chemotherapy (0.75 ± 0.27 SD). The authors also reported that patients who were being followed in ongoing remission also trended to higher health status values (mean 0.88 ± 0.21) compared to those who were not in remission (0.80 ± 0.22 SD; $p=0.15$).

Health state utilities used in the economic model

The economic model included in the MS⁶¹ uses utility values from the Oxford Outcomes study.^{120,119} The manufacturer assumed that the utility in PFS1 was similar to the utility of patients considered to be disease free (0.88; CI: 0.81- 0.95). The utility for patients in remission/full response to therapy (0.79; CI: 0.72 – 0.86) was used to represent the utility for patients in PFS2. Finally, the utility for progressive disease was assumed to be 0.62 (CI: 0.48 – 0.76).

The ERG in the ongoing appraisal for first-line maintenance suggested that it is inappropriate to assume that patients in PFS1 and PFS2 have different utility values given that these patients are in remission.¹²⁷ The ERG also noted that the utility for patients in the progressive state was estimated from a small sample size (n = 33) and did not account for patients that would be in “remission” in the third/subsequent lines of treatment. In addition to these limitations, the AG noted that using the utility for patients considered to be “disease free” to represent the utility in patients in PFS1 also appears to be inappropriate as these patients are in a “remission” state and not “disease-free”.^{120,119} The Oxford Outcomes Study^{120,119} reported additional analyses aggregating health states into “disease progression” and “progression free” (Table 50). This was considered more appropriate by the AG as the health state utilities in the main analysis were calculated from the degree of response to therapy and not the number of lines of treatment. Furthermore, aggregating utility values provided larger sample sizes and was expected to decrease the uncertainty and potential inaccuracy in the mean estimate. There also appears to be some errors in some of the sub-group analysis (see Table 50).

In the base case, the utility value in PFS1 and PFS2 was assumed to be 0.805, against 0.7363 for patients in the progressive health state (Table 50). Sensitivity analyses were conducted to examine the impact of health related quality of life in the ICER. Health state utilities were varied by $\pm 20\%$. The values included in the MS⁶¹ were also examined in sensitivity analyses. Health state utilities from a separate source¹⁴⁵ were also tested.

Utilities were varied in the PSA assuming a beta distribution. We assumed that the standard error for the utility in progressive state was 5% around the mean in the absence of information in the study. Utility values were not age-adjusted.

Analytic methods

Results are presented in terms of mean undiscounted life years, discounted lifetime costs and discounted QALYs.

The following strategies were compared and the ICER was calculated for;

- CVP against R-CVP,
- CHOP against R-CHOP,
- MCP against R-MCP.

Incremental analyses to determine the most cost-effective combination of chemotherapy with or without rituximab were not conducted by the AG as this was not considered relevant. Discussions with our clinical experts suggested that the choice of chemotherapy was based on additional factors such as patient's disease characteristics and/or the presence of co-morbidities as well as the efficacy of the regimen.

A range of scenarios were presented varying the main model assumptions to identify parameters that had the greatest impact on the ICER.

Probabilistic sensitivity analysis were also carried out using Monte Carlo simulation. The uncertainty in each parameter was represented using a probability distribution. The distribution with the key model parameters are presented in Table 52. The decision uncertainty was shown as the probability that each intervention is the most cost-effective at a given cost-effectiveness threshold. The probability of being the most cost-effective intervention was provided for WTP thresholds of £20,000 and £30,000 per QALY gained.

Table 52: Summary of parameters used in the economic model

Description	Deterministic	PSA – distribution	Source
Gender distribution			
Number of males	879	✓	Registry data in England ³ and Wales ^a
Number of females	990	(Beta distribution)	
Age distribution	see Figure 15	X	Registry data in England ³ and Wales ^a
All cause mortality (Gompertz distribution)			
Scale (male)	0.0000312171	X	Derived from UK life table ¹³⁶
Shape (male)	0.0965411930		
Scale (female)	0.0000115556		
Shape (female)	0.1042325152		
Body Surface Area	see Table 35	✓ (Normal distribution)	Derived from the height and weight from the PRIMA study ^{69,125}
Response rate	see Table 36 & Table 39	✓ (Beta distribution)	First-line induction trials ^{95,94,91,90,92} and second-line induction trial ^{72,71}
PFS in responders and non responders to first-line induction treatment	see Figure 19 & Figure 23	✓ (Multivariate normal distribution)	Analysis of patient level data from the M39021 trial ^{95,94} , provided by the manufacturer (Roche, personal communication, 15/11/2011)
PFS for responders in 2nd line treatment with CHOP or R-CHOP with or without maintenance (Log-normal distribution – Figure 28 & Figure 29)			
Scale (CHOP)	2.394999	✓ (Normal distribution, the Scale parameter was varied assuming a standard error of 5% around the Scale)	Derived from Van Oers <i>et al.</i> ⁷¹
Shape (CHOP)	0.167823		
Scale (CHOP-R)	3.623044		
Shape (CHOP-R)	0.381342		

Description	Deterministic	PSA – distribution	Source
Scale (R-CHOP)	3.277728		
Shape (R-CHOP)	0.633029		
Scale (R-CHOP-R)	3.984251		
Shape (R-CHOP-R)	0.643069		
PFS for non-responders in 2nd line treatment with CHOP or R-CHOP with or without maintenance (Log-normal distribution – Figure 31)			
Scale (CHOP)	2.389454	✓ (Normal distribution, the Scale parameter was varied assuming a standard error of 5% around the Scale)	Derived from Van Oers <i>et al.</i> ⁷¹
Shape (CHOP)	0.210479		
Scale (CHOP-R)	2.741266		
Shape (CHOP-R)	0.359914		
OS for responders in 2nd line (Log-normal distribution – Figure 30)			
Scale (Observation)	4.623707	✓ (Normal distribution, the Scale parameter was varied assuming a standard error of 5% around the Scale)	Derived from Van Oers <i>et al.</i> ⁷¹
Shape (Observation)	0.288565		
Scale (maintenance)	5.104284		
Shape (maintenance)	0.385508		
OS for non-responders in 2nd line (Log-normal distribution – Figure 31)			
Scale	3.759047	✓ (Normal distribution, the Scale parameter was varied assuming a standard error of 5% around the Scale)	Derived from Van Oers <i>et al.</i> ⁷¹
Shape	0.453447		
PFS for patients receiving salvage treatment in second-line (Log-normal distribution – Figure 33)			
Scale (HDT)	3.092036	✓ (Normal distribution, the Scale parameter was varied assuming a standard error of 5% around the Scale)	Derived from Sebban <i>et al.</i> ¹³⁵
Shape (HDT)	0.406642		
Scale (HDT +R)	4.179713		
Shape (HDT + R)	0.137204		
OS for patients receiving salvage treatment in second-line (Log-normal distribution – Figure 34)			
Scale (HDT)	3.835276	✓ (Normal distribution, the	Derived from Sebban <i>et al.</i> ¹³⁵
Shape (HDT)	0.498643		

Description	Deterministic	PSA – distribution	Source
Scale (HDT +R)	5.675053	Scale parameter was varied assuming a standard error of 5% around the Scale)	
Shape (HDT + R)	0.506431		
Proportion of AE	see Table 41	✓ (Beta distribution)	First-line induction trials ^{95,94,91,90,92}
Cost of AE	see Table 41	✓ (Normal distribution, assuming a standard error of 5% around the mean costs)	MS for ongoing maintenance appraisal ¹²⁵
Health state Utility			
PFS1, PFS2	0.805 (0.018 SE)	✓ (Beta distribution)	Wild <i>et al.</i> ^{119,120}
PD	0.7633 (SE assumed to be 5% around the mean)		Wild <i>et al.</i> ^{119,120}
Monitoring cost, administration cost	see Table 43 and Table 47	✓ (Lognormal distribution or normal distribution assuming a standard error of 5% around the mean costs)	See Table 43 and Table 47
Cost 3rd line	see Table 48	✓ (Normal distribution, assuming a standard error of 5% around the mean costs)	Derived from Van Oers <i>et al.</i> ⁷¹ and units used in TA 137 by the MS ⁷⁰
Cost palliative care	£4,077	✓ (Normal distribution, assuming a standard error of 5% around the mean costs)	Guidance on Cancer Services ¹²⁶

^a Welsh Cancer Intelligence & Surveillance Unit 2008

6.4.2 Results of the ScHARR economic assessment

Results are presented for two scenarios:

- Base case analysis assuming no first-line maintenance in patients responding to R-chemotherapy first-line induction,
- Scenario analysis incorporating first-line maintenance in patients responding to R-chemotherapy first-line induction.

Base case analysis assuming no first-line maintenance in patients responding to R-chemotherapy first-line induction

Deterministic results

The results of the deterministic base case cost-effectiveness analysis are presented in Table 53, 54 and 55. Analyses indicate that the addition of rituximab to CVP leads to a gain of 0.96 discounted QALYs for an additional cost of about £7,389. The cost per QALY gained of CVP in combination with rituximab compared with CVP alone is £7,720 (Table 53).

Table 53: Base case deterministic cost-effectiveness of the addition of rituximab to CVP estimated by the AG

	Undiscounted LY	Discounted Cost	Discounted QALY
CVP	9.86	£30,793	5.99
R-CVP	11.50	£38,183	6.95
Cost per QALY			£7,720

The addition of rituximab to CHOP leads to a gain of 0.53 QALYs for an additional cost of £5,725. The cost per QALY gained of CHOP in combination with rituximab compared with CHOP alone is £10,834 (Table 54).

Table 54: Base case deterministic cost-effectiveness of the addition of rituximab to CHOP estimated by the AG

	Undiscounted LY	Discounted Cost	Discounted QALY
CHOP	11.55	£34,983	6.84
R-CHOP	12.40	£40,708	7.37
Cost per QALY			£10,834

Finally, the addition of rituximab to MCP leads to a gain of 0.57 QALYs for an additional cost of about £5,267. The cost per QALY gained of MCP in combination with rituximab compared with MCP alone is £9,316 (Table 55).

Table 55: Base case deterministic cost-effectiveness of the addition of rituximab to MCP estimated by the AG

	Undiscounted LY	Discounted Cost	Discounted QALY
MCP	11.45	£36,103	6.79
R-MCP	12.35	£41,370	7.36
Cost per QALY			£9,316

Patients treated without rituximab in first-line induction spend less time in PFS1, but generally more time in PFS2 and in the progressive disease health state compared to patients receiving chemotherapies in addition to rituximab (Figure 36). A similar pattern is observed for the accrued QALYs (Figure 37). The fact that more patients in the R-chemotherapy group do not progress before death than in the chemotherapy group means that the average time in PFS1 is longer for the R-chemotherapy group, but the average duration in PFS2 and PD are shorter, as the patients who remain in PFS1 have zero times within these states.

Figure 36: Base case analysis: undiscounted life years

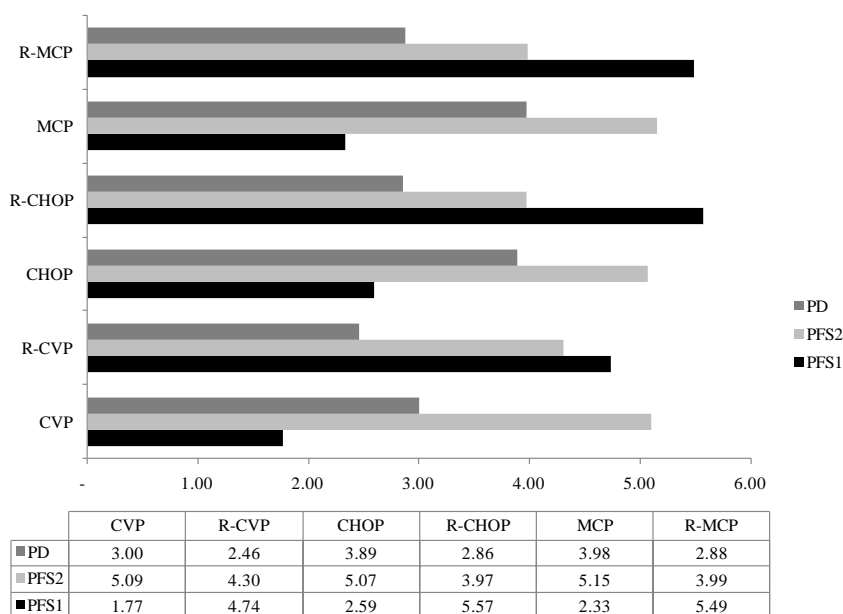

Undiscounted Life Years

Figure 37: Base case analysis: discounted QALYs

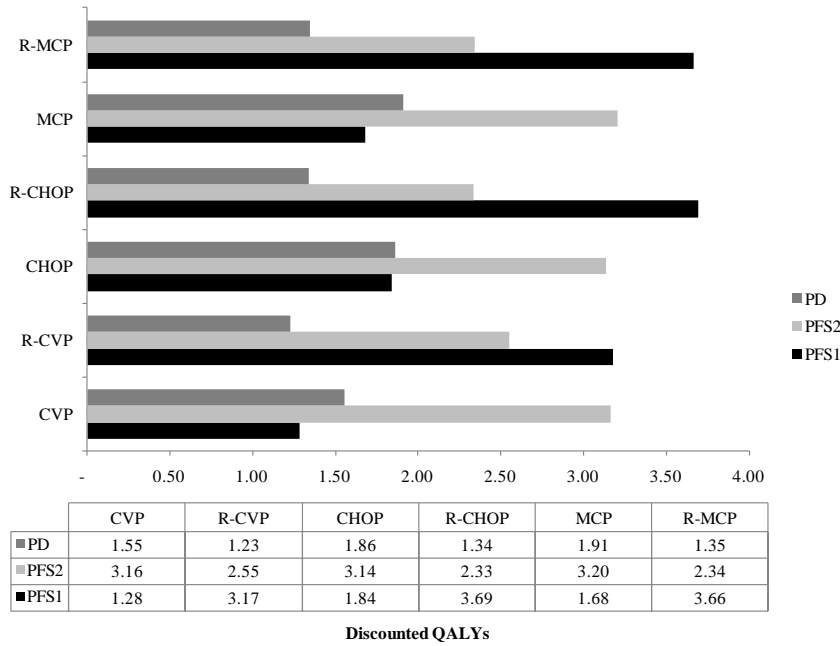

The addition of rituximab is associated with an increase in treatment costs, the management of adverse events and monitoring/surveillance in first-line induction treatment compared with patients treated with chemotherapy alone (Figure 38, 39 and 40). However, patients treated with chemotherapy alone incur more costs in second-line and subsequent lines of treatment.

Figure 38: Base case analysis: management and treatment costs for patients treated with CVP in first-line induction with or without rituximab

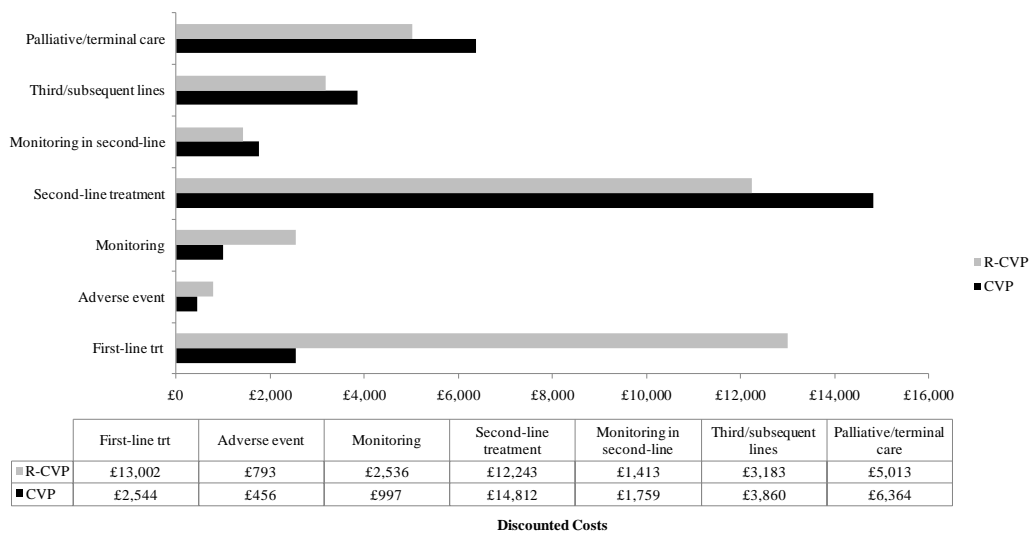

Figure 39: Base case analysis: management and treatment costs for patients treated with CHOP in first-line induction with or without rituximab

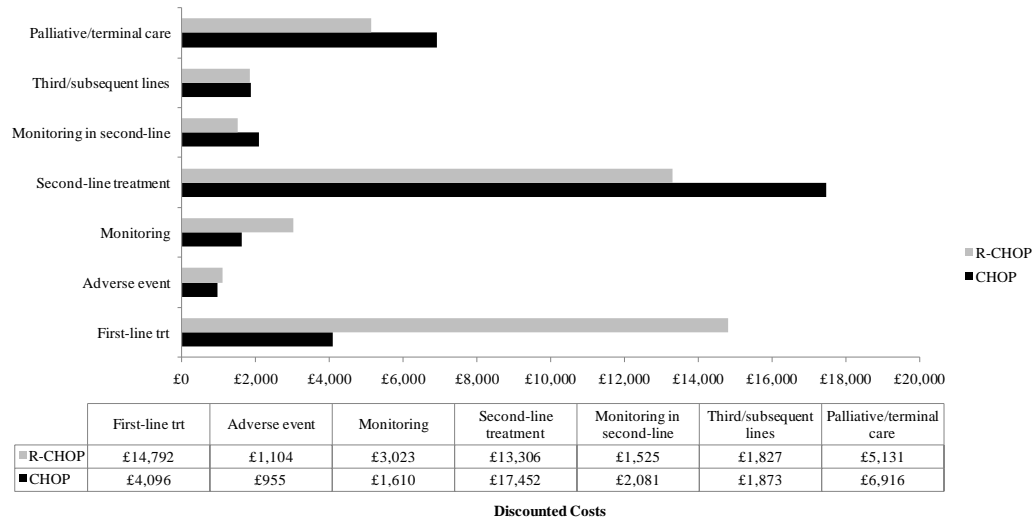
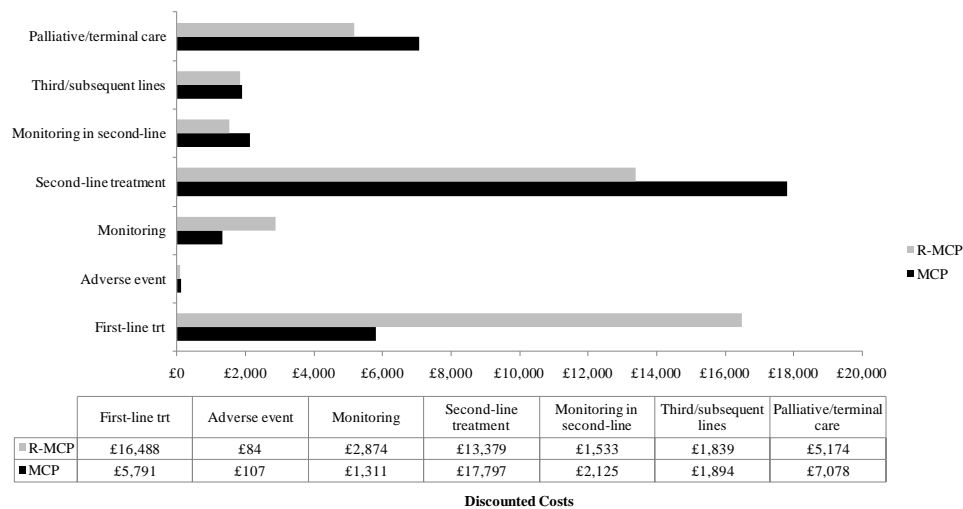

Figure 40: Base case analysis: management and treatment costs for patients treated with MCP in first-line induction with or without rituximab



Probabilistic results

The ICER in the PSA for the addition of rituximab to CVP, CHOP and MCP is estimated to be £7,735, £10,855 and £9,313 per QALY gained respectively (Table 56, Table 57, Table 58). The probabilities of being cost-effective at different WTP thresholds are presented in Figure 41, Figure 42 and Figure 43 for R-CVP vs. CVP, R-CHOP vs. CHOP and R-MCP vs. MCP respectively. The CEAC show that the addition of rituximab to chemotherapy (CVP, CHOP and MCP) in first-line induction have a high probability of being cost-effective at a cost-effectiveness threshold of £20,000 per QALY gained.

The probabilities of the addition of rituximab to CVP being cost-effective compared with CVP alone are 100% when assuming a WTP of £20,000 and £30,000 per QALY gained respectively (Table 56, Figure 41).

Table 56: Base case analysis: Probabilistic cost-effectiveness of the addition of rituximab to CVP estimated by the AG

	Undiscounted LY	Discounted Cost	Discounted QALY	Probability CE at 20K	Probability CE at 30K
CVP	9.91	£30,651	6.02		
R-CVP	11.56	£38,050	6.97		
Cost per QALY			£7,735	100.00%	100.00%

Figure 41: Base case analysis: CEAC for R-CVP versus CVP alone

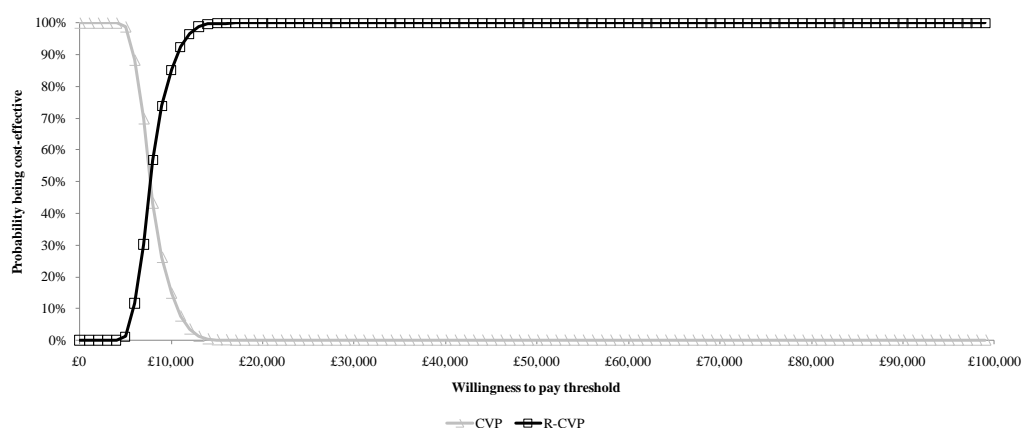

The probabilities of the addition of rituximab to CHOP being cost-effective compared with CHOP alone are 88.50% and 95.70% assuming a WTP of £20,000 and £30,000 per QALY gained respectively (Table 57, Figure 42).

Table 57: Base case analysis: Probabilistic cost-effectiveness of the addition of rituximab to CHOP estimated by the AG

	Undiscounted LY	Discounted Cost	Discounted QALY	Probability CE at 20K	Probability CE at 30K
CHOP	11.60	£34,881	6.85		
R-CHOP	12.39	£40,608	7.38		
Cost per QALY			£10,855	88.50%	95.70%

Figure 42: Base case analysis: CEAC for R-CHOP versus CHOP alone

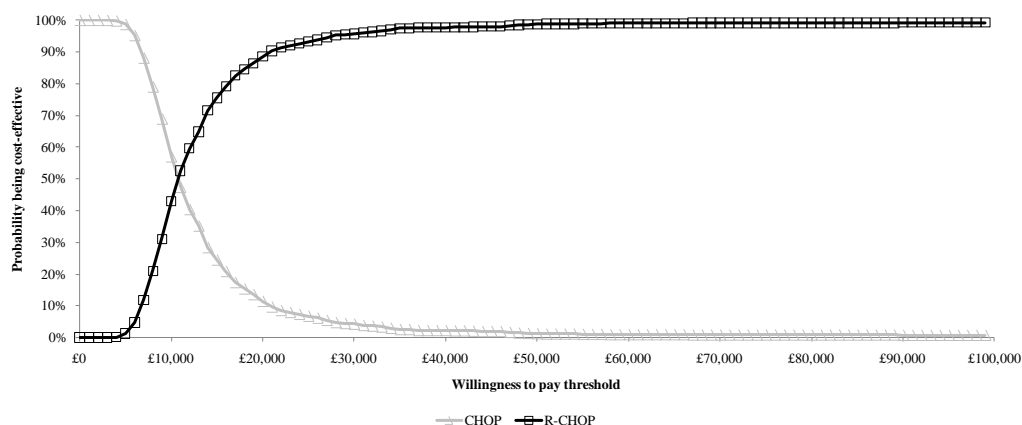

The probabilities of the addition of rituximab to MCP being cost-effective compared with MCP alone are 92.10% and 96.70% assuming a WTP of £20,000 and £30,000 per QALY gained respectively (Table 58, Figure 43).

Table 58: Base case analysis: probabilistic cost-effectiveness of the addition of rituximab to MCP estimated by the AG

	Undiscounted LY	Discounted Cost	Discounted QALY	Probability CE at 20K	Probability CE at 30K
MCP	11.50	£35,970	6.80		
R-MCP	12.21	£41,248	7.37		
Cost per QALY			£9,313	92.10%	96.70%

Figure 43: Base case analysis: CEAC for R-MCP versus MCP alone

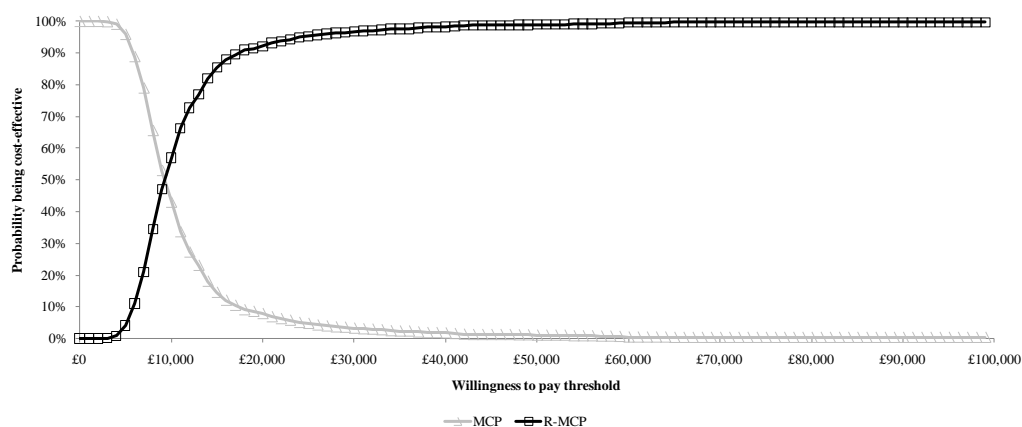

Univariate sensitivity analyses: Impact of main model parameters

A range of univariate sensitivity analyses were undertaken to assess the impact of main model parameters and assumption on the cost per QALY gained. Full results of sensitivity analyses performed are presented in Appendix 15 for the comparison between R-CVP and CVP, R-CHOP and CHOP and R-MCP and MCP.

The main findings from the sensitivity analyses are described below.

SA1: Varying the time horizon

We explored different time horizon (5 years, 10 years and lifetime). The ICER was sensitive to the assumption about the time horizon and becomes more favourable to rituximab for all comparisons as the time horizon increases (Table 59).

Table 59: SA: Varying the time horizon

Time horizon	R-CVP vs. CVP	R-CHOP vs. CHOP	R-MCP vs. MCP
Base case (25 years)	£7,720	£10,834	£9,316
5 years	£20,998	£33,975	£24,366
10 years	£11,287	£16,650	£13,598
Lifetime	£7,360	£10,362	£8,963

SA2: Varying the discount rates

We explored different assumptions about the discount rates, assuming either no discounting and either costs or benefits discounted. Results were not sensitive to the assumption about discounting (Appendix 15). As an illustration, the ICER for R-CHOP versus CHOP ranged from £11,788 (assuming no discounting for costs but QALY discounted at 3.5%) to £7,634 (assuming no discounting for QALYs but costs discounted at 3.5%) per QALY gained.

SA3: Parametric distribution used to model the effectiveness in first-line

In the base case, the effectiveness was modelled fitting a Log-normal to the KM curve from the M39021 trial.^{95,94} In sensitivity analyses, we explored the use of two alternative distributions (Gompertz and Weibull distributions). These two distributions were selected as they provided a plausible but different extrapolation compared to the Log-normal distribution. The ICER was broadly similar (Table 60) assuming a Weibull distribution compared with our base case assumption (Log-normal extrapolation). However, the ICER was particularly sensitive if a Gompertz distribution was selected (Table 60). For example, the ICER of R-CHOP against CHOP was £3,941 per QALY gained when assuming a Gompertz distribution, compared to £10,834 using a Log-normal distribution (base case assumption).

Table 60: SA: Choice of parametric distribution

Distribution	R-CVP vs. CVP	R-CHOP vs. CHOP	R-MCP vs. MCP
Base case	£7,720	£10,834	£9,316
Weibull	£8,054	£12,030	£10,594
Gompertz	£4,174	£3,941	£3,146

The Differences between the Log-normal and Gompertz estimates are probably caused by differences in the extrapolation at the end of clinical evidence, with the risk of progression using the Gompertz distribution flattening out after about 60 months (Figure 44).

As both curves provided a plausible fit to the observed data, the ICERs may be overestimated. However, as FL is usually considered as incurable, the Gompertz extrapolation might not be plausible.

Figure 44: Comparison of the extrapolation using the Log-normal and Gompertz distribution for responders to R-CVP

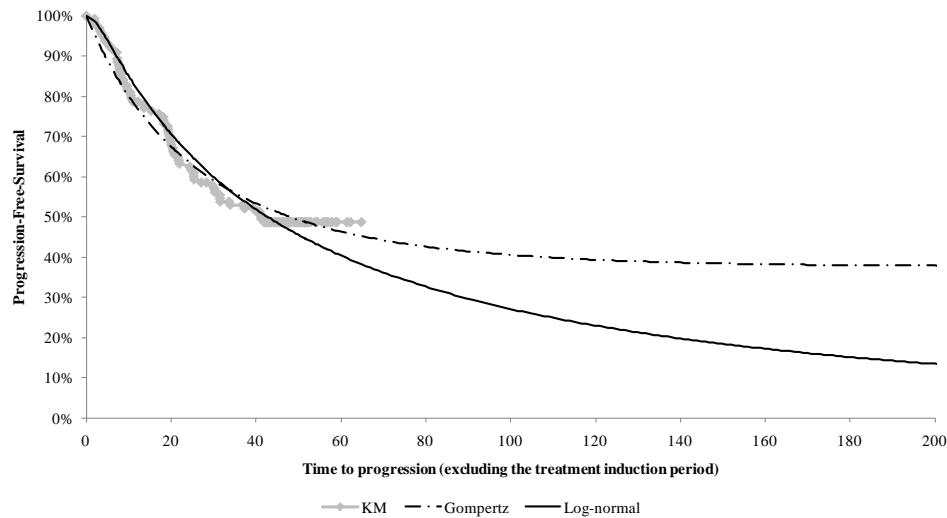

S4: Varying the proportion of progression attributable to death

The proportion of progression attributable to death in first-line induction was derived from the M39021 trial.^{95,94,61} Sensitivity analyses were conducted assuming that no progressions are attributable to death or that the same proportion of progression is attributable to death in the two arms (Table 61). The impact on the ICER was minimal.

Table 61: SA: Varying the rate of progression attributable to death

	R-CVP vs. CVP	R-CHOP vs. CHOP	R-MCP vs. MCP
Base case (5% for CVP, 3% for R-CVP)	£7,720	£10,834	£9,316
None	£8,224	£13,463	£11,192
Using the rate from the CVP arm in both arms	£7,984	£11,872	£10,023
Using the rate from the R-CVP arm in both arms	£8,080	£12,470	£10,457

SA5: Examining the effect of resistance to rituximab in previously exposed patients

As previously mentioned, the effect of rituximab resistance after re-treatment with rituximab is unknown. In the base case, we assumed the same rate of progression after rituximab in combination with chemotherapy or salvage therapy in rituximab naive or rituximab pre-treated patients.

A sensitivity analysis was conducted exploring the potential impact of resistance among previously treated patients with rituximab. The resistance was modelled by reducing the rate of progression or death of rituximab in second-line for patients previously treated with rituximab. A reduction up to 30% was examined in sensitivity analyses to avoid the rate of progression/death in second-line being higher for patients not receiving rituximab as part of the second-line treatment.

The ICER was very sensitive when a lower effectiveness was assumed in patients previously treated with rituximab (Table 62). For example, the ICER for R-CHOP against CHOP was greater than £20,000 per QALY gained if a reduction in effectiveness of 20% or greater was assumed (Table 62).

Table 62: SA: Assuming a reduced effectiveness in second-line, in patients previously treated with rituximab

Reduced effectiveness in previously treated rituximab patients	R-CVP vs. CVP	R-CHOP vs. CHOP	R-MCP vs. MCP
Base case	£7,720	£10,834	£9,316
-10%	£9,379	£13,843	£11,718
-15%	£10,616	£16,328	£13,632
-20%	£12,328	£20,163	£16,494
-25%	£14,870	£26,939	£21,253
-30%	£19,102	£42,361	£30,902

Results of this sensitivity analysis have to be considered with caution, as the existence of a resistance effect is unknown, and if it does exist, how this would translate.

SA 6: Examining the maximum time a patient can stay in PFS1

In the base case, a proportion of patients might not progress and remain in PFS1 during the entire simulation because of the parametric extrapolation. We examined a scenario where we truncated the survival curves, assuming that patient can remain in PFS1 only for a maximum duration.

As expected, the ICER was very sensitive to this assumption. The ICER for the addition of rituximab to CHOP and MCP rose to over £20,000 per QALY gained if patients were assumed to be progression-free in first-line for a maximum duration of approximately 9 years (Table 63).

Table 63: SA: Varying the maximum time a patient can stay in PFS1

Maximum time a patient can stay in PFS1	R-CVP vs. CVP	R-CHOP vs. CHOP	R-MCP vs. MCP
Base case	£7,720	£10,834	£9,316
5 years	£16,656	£43,733	£36,602
6 years	£14,527	£32,857	£27,820
7 years	£13,044	£26,749	£22,799
8 years	£11,964	£22,835	£19,527
9 years	£11,143	£20,149	£17,277
10 years	£10,513	£18,210	£15,642
11 years	£10,016	£16,745	£14,403
12 years	£9,613	£15,607	£13,437
13 years	£9,287	£14,718	£12,685
14 years	£9,018	£13,999	£12,074
15 years	£8,797	£13,427	£11,584
16 years	£8,616	£12,963	£11,188
17 years	£8,461	£12,576	£10,855
18 years	£8,331	£12,256	£10,579
19 years	£8,223	£11,995	£10,352

SA 7: Increasing OS in patients receiving rituximab in addition to chemotherapy in second-line induction treatment

In the base case analysis, we assumed the same OS for patients treated with CHOP (FC) and R-CHOP (R-FC) in second-line induction after maintenance or observation. A sensitivity analysis was presented assuming an increase in the mean OS for patients receiving R-CHOP or R-FC in second-line induction treatment compared to CHOP or FC. As shown in Table 64, the impact on the cost per QALY was modest. This sensitivity analysis mainly effects the comparison between CVP against R-CVP as patients treated with CHOP or MCP regimens do not receive CHOP or R-CHOP in second-line induction treatment but only FC and R-FC if aged over 65 years.

The ICER increases as more patients treated with chemotherapy alone are expected to receive rituximab as part of their second-line.

Table 64: SA: Assuming a higher survival in patients treated with rituximab in second-line

Increase in mean OS	R-CVP vs. CVP	R-CHOP vs. CHOP	R-MCP vs. MCP
Base case	£7,720	£10,834	£9,316
5%	£8,067	£11,213	£9,620
10%	£8,441	£11,588	£9,918
15%	£8,837	£11,950	£10,208
20%	£9,232	£12,283	£10,468
25%	£9,613	£12,565	£10,691

SA 8: Health state utility values

There were uncertainties in the health state utility values used in the economic model. In the base case, we assumed that the utility values in PFS1, PFS2 and progressive health state were 0.805, 0.805 and 0.7366 respectively.

A sensitivity analysis was conducted assuming the same utility values as in the MS (0.880, 0.790 and 0.620) and resulted in an improvement in the ICER (Table 65). A sensitivity analysis was also performed using utility values estimated in Canada in a cohort of patients with different types of lymphoma (0.84, 0.81, 0.74)¹⁴⁵ and showed a modest impact on the ICER (Table 65).

We examined a reduction in utility values ranging from 10% to 30%. Assuming a reduction in utility values of 30% had a modest impact on the ICER. A scenario is presented assuming that the utility in PFS1 is 10% higher compared to the utility values in PFS 2. The impact on the ICER was modest.

Finally, a range of sensitivity analyses were conducted examining different assumptions about disutility due to adverse events. These had a minimal impact on the ICER.

Table 65: SA: Varying health state utilities

Health state utility values	R-CVP vs. CVP	R-CHOP vs. CHOP	R-MCP vs. MCP
Base case	£7,720	£10,834	£9,316
Utility values used in the MS ⁶¹	£6,180	£7,167	£6,165
Utility values estimated in a mixed cohort of lymphoma patients ¹⁴⁵	£7,147	£9,518	£8,186
Reduction in utility values by 10%	£8,578	£12,038	£10,352
Reduction in utility values by 20%	£9,650	£13,543	£11,646
Reduction in utility values by 30%	£11,029	£15,478	£13,309
Assuming a 10% higher utility values in PFS1 compared to PFS2	£6,447	£8,019	£6,898
Assuming no disutility	£7,704	£10,760	£9,291
Disutility of 10%	£7,715	£10,809	£9,308
Disutility of 20%	£7,725	£10,860	£9,325
Disutility of 30%	£7,736	£10,910	£9,342

SA 9: Changes in the treatment pathway

Changes in the treatment pathway were examined given the shortcoming in evidence available. Overall, using different evidence to model the effect of second-line treatment had a modest impact on the cost per QALY. Assuming that patients treated with CHOP or MCP regimens in first-line induction regimens received CHOP or R-CHOP in second-line instead of HDT ± ASCT had a modest impact on the cost per QALY gained (Table 66). Similarly, we examined a scenario where older patients received CHOP and R-CHOP in second-line induction instead of FC and R-FC. The impact on the cost per QALY was minimal (Table 66).

The ICER was mainly sensitive whether the same treatment was given post-progression for patients previously treated with R-chemotherapy or chemotherapy alone.

Table 66: SA: Varying the modelled treatment pathway

Modelled treatment pathway	R-CVP vs. CVP	R-CHOP vs. CHOP	R-MCP vs. MCP
Base case	£7,720	£10,834	£9,316
Patients receive second-line after progression only	£9,230	£10,945	£10,125
Patients on R-CVP are not re-treated with rituximab in second-line if early relapse	£8,123	£10,834	£9,316
Patients treated with an anthracycline regimen receive CHOP with or without rituximab in second-line	£7,720	£8,058	£7,155
Older patients receive with or without rituximab in second-line	£7,742	£10,833	£9,232
Combination of the three previous scenarios	£7,841	£7,967	£7,035
All patients receive R-HDT	£8,506	£8,745	£7,574
All patients receive HDT	£6,159	£6,245	£5,604
All patients receive CHOP	£7,553	£7,714	£6,907
All patients receive R-CHOP	£7,742	£7,933	£7,041

SA 10: Effectiveness of FC containing regimens in older patients

We also examined different assumptions about the effectiveness of FC containing regimens in older patients assuming a reduced effectiveness compared to CHOP containing regimens. The impact on the cost per QALY was minimal with the ICER for R-CHOP against CHOP ranging from £10,019 (reduction in the rate of progression by 30%) £11,268 (response rate reduced by 10% compared to CHOP/R-CHOP)

SA 11: Assumption about response to HDT±R, proportion of patients with successful harvest and cycles of HDT

There were considerable uncertainties about the response rate for HDT, the proportion of patients with successful harvest and number of cycles of HDT.

In sensitivity analyses we varied the response rate of HDT, assuming different success rates for harvest and assuming up to 4 cycles of HDT. The impact on the ICER was

minimal with the ICER ranging from £9,430 (assuming 4 cycles) to £11,221 (assuming the same response rate as CHOP/R-CHOP) per QALY gained for the comparison between R-CHOP and CHOP (Appendix 15).

SA 12: Adverse events

Assumptions of the occurrence (assuming no adverse event) and management costs of adverse events ($\pm 20\%$) had a minimal impact on the cost per QALY for all regimens (Appendix 15).

SA 13: Number of cycles for patients treated with CHOP/R-CHOP in first-line induction

The ICER between R-CHOP and CHOP improved assuming that patients only receive 6 cycles (£5,951 per QALY gained compared to £10,834 in the base case)

SA 14: Management costs

The ICER was not very sensitive to assumptions about management costs (Table 67).

Table 67: SA: Varying management costs

Management costs	R-CVP vs. CVP	R-CHOP vs. CHOP	R-MCP vs. MCP
Base case	£7,720	£10,834	£9,316
Adm cost +20%	£7,724	£10,859	£9,370
Adm cost -20%	£7,716	£10,810	£9,263
Rx pharm (£35)	£7,847	£11,089	£9,549
No monitoring	£6,475	£9,214	£7,600
Monitoring +20%	£7,969	£11,159	£9,660
Monitoring -20%	£7,471	£10,510	£8,973
No 3rd line cost	£8,427	£10,921	£9,413
No palliative care	£8,715	£13,744	£12,228
No terminal care	£8,138	£11,303	£9,773
No palliative or terminal care	9,132	£14,213	£12,684

Adm= administration; Rx pharm= Rituximab pharmacy

SA 15: Maximum age at transplant/aggressive therapies

Varying the maximum age at which patients can receive aggressive therapies (60 – 80 years) had a small impact on the cost per QALY gained (Table 68).

Table 68: SA: Varying the maximum age at which patients can receive aggressive therapies

Age to receive aggressive therapies	R-CVP vs. CVP	R-CHOP vs. CHOP	R-MCP vs. MCP
Base case	£7,720	£10,834	£9,316
60 years	£7,690	£9,832	£8,528
70 years	£7,735	£11,758	£9,973
75 years	£7,748	£12,763	£10,659
80 years	£7,747	£13,377	£11,099

SA 16: Body Surface Area

Finally, the impact in model results of varying the BSA was minimal (Table 69).

Table 69: SA: Varying the BSA

BSA	R-CVP vs. CVP	R-CHOP vs. CHOP	R-MCP vs. MCP
Base case	£7,720	£10,834	£9,316
1.6	6,095	7,384	6,164
1.7	7,192	9,712	8,289
1.8	7,192	9,712	8,289
1.9	8,318	12,094	10,469

Scenario analysis: including first-line maintenance with rituximab in responders to R-chemotherapy

The AG explored a scenario where first-line maintenance was incorporated into the treatment pathway. At the time of writing of the report, no guidance has been issued by NICE, and therefore, results are presented to help the Appraisal Committee in case a positive recommendation is made by NICE for the use of rituximab monotherapy as a first-line maintenance treatment in patients responding to R-chemotherapy first-line induction.

Deterministic results incorporating first-line maintenance into the treatment pathway

The cost-effectiveness results for the scenario analysis incorporating first-line maintenance for responders to R-chemotherapy in first-line induction treatment are presented in Table 70, 71 and 72. Analyses indicate that the addition of rituximab to CVP leads to a gain of 1.25 discounted QALYs for an additional cost of about £18,727. The cost per QALY gained of CVP in combination with rituximab compared with CVP alone is £14,959 (Table 70).

Table 70: Scenario analysis: deterministic cost-effectiveness of the addition of rituximab to CVP estimated by the AG

	Undiscounted LY	Discounted Cost	Discounted QALY
CVP	9.86	£30,793	5.99
R-CVP	12.03	£49,520	7.25
Cost per QALY			£14,959

The addition of rituximab to CHOP leads to a gain of 0.88 QALYs for an additional cost of £19,150. The cost per QALY gained of CHOP in combination with rituximab compared with CHOP alone is £21,687 (Table 71).

Table 71: Scenario analysis: deterministic cost-effectiveness of the addition of rituximab to CHOP estimated by the AG

	Undiscounted LY	Discounted Cost	Discounted QALY
CHOP	11.55	£34,983	6.84
R-CHOP	13.02	£54,134	7.72
Cost per QALY			£21,687

Finally, the addition of rituximab to MCP leads to a gain of 0.88 QALYs for an additional cost of about £17,976. The cost per QALY gained of MCP in combination with rituximab compared with MCP alone is £20,493 (Table 72).

Table 72: Scenario analysis: deterministic cost-effectiveness of the addition of rituximab to MCP estimated by the AG

	Undiscounted LY	Discounted Cost	Discounted QALY
MCP	11.45	£36,103	6.79
R-MCP	12.89	£54,079	7.67
Cost per QALY			£20,493

Details about the number of life years, discounted QALY and costs by health states are presented in Appendix 16.

Probabilistic results for the scenario analysis incorporating first-line maintenance rituximab in responders to R-chemotherapy

The ICER in the PSA for the addition of rituximab to CVP, CHOP and MCP are estimated to be £15,017, £21,625 and £20,418 respectively (Table 73, Table 74, Table 75). The probabilities of being cost-effective at different WTP thresholds are presented in Figure 45, Figure 46 and Figure 47 for R-CVP vs. CVP, R-CHOP vs. CHOP, R-MCP vs. MCP respectively.

The probabilities of the addition of rituximab to CVP being cost-effective compared with CVP alone are 95.60% and 100.00% assuming a WTP of £20,000 and £30,000 per QALY gained respectively (Table 73, Figure 45).

Table 73: Scenario analysis: probabilistic cost-effectiveness of the addition of rituximab to CVP estimated by the AG

	Undiscounted LY	Discounted Cost	Discounted QALY	Probability CE at 20K	Probability CE at 30K
CVP	9.91	£30,651	6.02		
R-CVP	12.09	£49,477	7.27		
Cost per QALY			£15,017	95.60%	100.00%

Figure 45: Scenario analysis: CEAC for R-CVP versus CVP alone

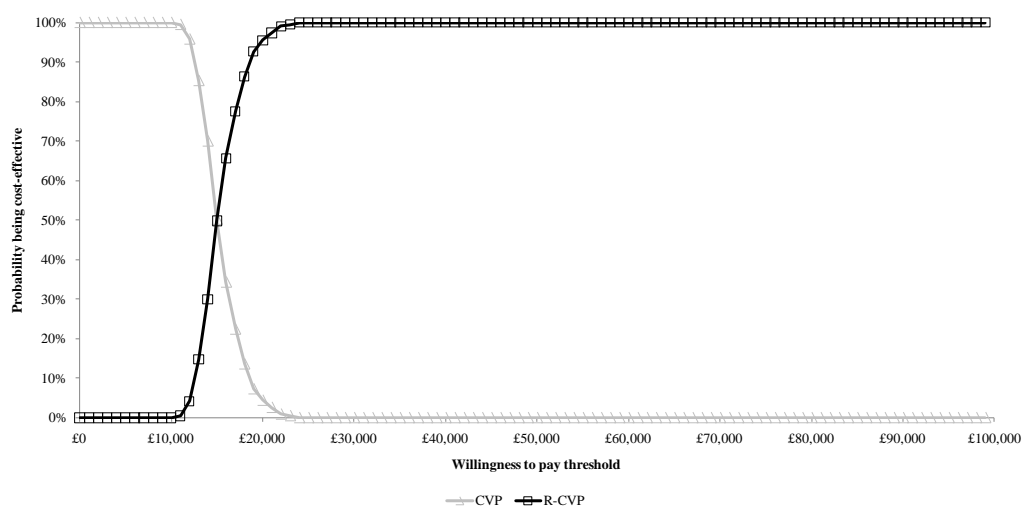

The probabilities of the addition of rituximab to CHOP being cost-effective compared with CHOP alone are 36.00% and 91.50% assuming a WTP of £20,000 and £30,000 per QALY gained respectively (Table 74, Figure 46).

Table 74: Scenario analysis: probabilistic cost-effectiveness of the addition of rituximab to CHOP estimated by the AG

	Undiscounted LY	Discounted Cost	Discounted QALY	Probability CE at 20K	Probability CE at 30K
CHOP	11.60	£34,881	6.85		
R-CHOP	12.94	£54,063	7.74		
Cost per QALY			£21,625	36.00%	91.50%

Figure 46: Scenario analysis: CEAC for R-CHOP versus CHOP alone

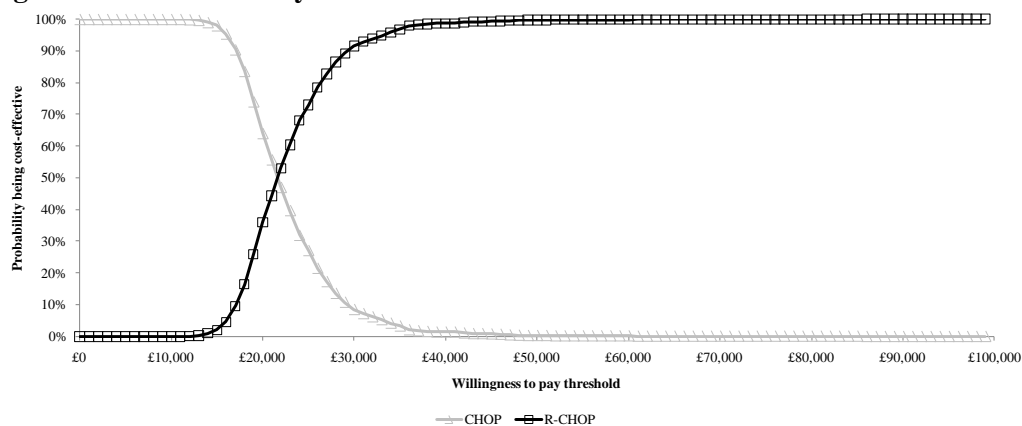

The probabilities of the addition of rituximab to MCP being cost-effective compared with MCP alone are 44.90% and 91.90% assuming a WTP of £20,000 and £30,000 per QALY gained respectively (Table 75, Figure 47).

Table 75: Scenario analysis: probabilistic cost-effectiveness of the addition of rituximab to MCP estimated by the AG

	Undiscounted LY	Discounted Cost	Discounted QALY	Probability CE at 20K	Probability CE at 30K
MCP	11.50	£35,970	6.80		
R-MCP	12.90	£54,004	7.69		
Cost per QALY			£20,418	44.90%	91.90%

Figure 47: Scenario analysis: CEAC for R-MCP versus MCP alone

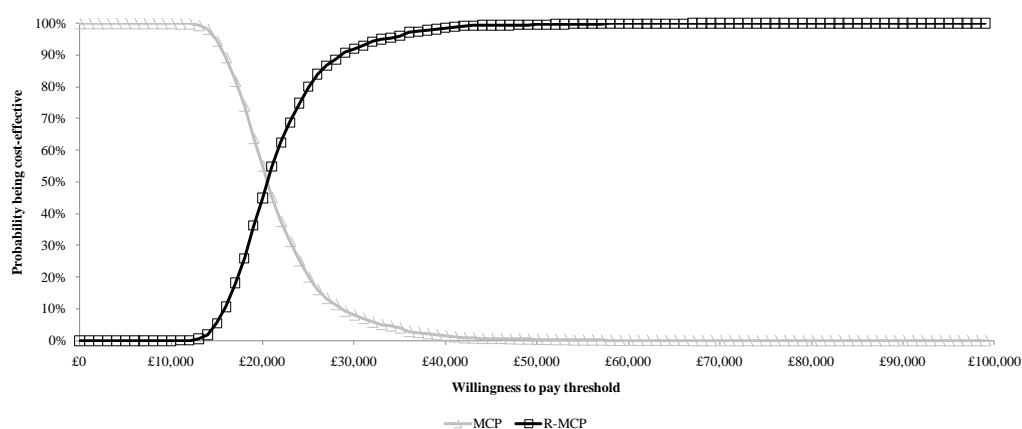

Univariate sensitivity analyses: Impact of main model parameters in the scenario analysis incorporating first-line maintenance in responders to R-chemotherapy

A range of univariate sensitivity analyses were undertaken to assess the impact of main model parameters and assumption on the cost per QALY gained. A limited number of sensitivity analysis are presented in the main section of the report for readability. Full results of sensitivity analyses performed are presented in Appendix 15 for the comparison between R-CVP and CVP, R-CHOP and CHOP and R-MCP and MCP for the scenario analysis.

SA1: Varying the time horizon

We explored different time horizons (5 years, 10 years and lifetime). The ICER was sensitive to the assumption about the time horizon with an improvement in the ICER for all comparisons as the time horizon increases (Table 76).

Table 76: SA: Varying the time horizon (scenario analysis)

Time horizon	R-CVP vs. CVP	R-CHOP vs. CHOP	R-MCP vs. MCP
Base case (25 years)	£14,959	£21,687	£20,493
5 years	£54,094	£91,356	£80,497
10 years	£24,126	£36,367	£33,482
Lifetime	£14,125	£20,533	£19,510

SA2: Parametric distribution used to model the effectiveness in first-line

Again, the ICER was very sensitive when a Gompertz distribution was used instead of a Log-normal distribution (Table 77).

Table 77: SA: Choice of parametric distribution (scenario analysis)

Distribution	R-CVP vs. CVP	R-CHOP vs. CHOP	R-MCP vs. MCP
Base case	£14,959	£21,687	£20,493
Weibull	£15,958	£23,824	£22,833
Gompertz	£9,419	£12,490	£11,653

SA3: Assuming different assumption about the effect of first-line maintenance

We also explored different assumptions about the effect of first-line maintenance, varying the hazard ratios using the confidence interval (0.48 – 0.66) or varying the assumption of the treatment duration effect (36 – 72 months). Results are presented in Table 78 and showed a modest impact on the cost per QALY gained.

Table 78: SA: Assumption about the effect of first-line maintenance rituximab (scenario analysis)

	R-CVP vs. CVP	R-CHOP vs. CHOP	R-MCP vs. MCP
Base case	£14,959	£21,687	£20,493
36 months	£15,469	£22,703	£21,436
48 months	14,524	£20,827	£19,712
60 months	£13,828	£19,478	£18,470
72 months	£13,305	£18,495	£17,547
HR: 0.48	£14,205	£20,051	£19,063
HR: 0.66	£16,210	£24,628	£23,044

SA 4: Examining the effect of resistance to rituximab in previously exposed patients

As previously mentioned, the effect of rituximab resistance after re-treatment with rituximab is unknown. In the base case, we assumed the same rate of progression after rituximab in combination with chemotherapy or salvage therapy in rituximab naive or rituximab pre-treated patients.

Again, the ICER was very sensitive when a lower effectiveness was assumed in patients previously treated with rituximab (Table 79).

Table 79: SA: Assuming a reduced effectiveness in second-line, in patients previously treated with rituximab (scenario analysis)

Reduced effectiveness in previously treated rituximab patients	R-CVP vs. CVP	R-CHOP vs. CHOP	R-MCP vs. MCP
Base case	£14,959	£21,687	£20,493
-10%	£16,851	£24,447	£23,067
-15%	£18,100	£26,301	£24,788
-20%	£19,650	£28,629	£26,946
-25%	£21,624	£31,646	£29,731
-30%	24,234	35,734	£33,489

SA 5: Examining the maximum time a patient can stay in PFS1

In the base case, a proportion of patients might no progress and remain in PFS1 during the entire simulation because of the parametric extrapolation. We examined a scenario where we truncated the survival curves, assuming that patient can remain in PFS1 only for a maximum duration.

Again, the ICER was very sensitive to this assumption.

Table 80: SA: Varying the maximum time a patient can stay in PFS1 (scenario analysis)

Maximum time a patient can stay in PFS1	R-CVP vs. CVP	R-CHOP vs. CHOP	R-MCP vs. MCP
Base case	£14,959	£21,687	£20,493
5 years	£31,354	£61,115	£60,170
6 years	£27,043	£49,043	£47,647
7 years	£24,178	£41,756	£40,277
8 years	£22,151	£36,904	£35,414
9 years	£20,651	£33,528	£32,065
10 years	£19,516	£31,050	£29,618
11 years	£18,645	£29,166	£27,766
12 years	£17,951	£27,698	£26,330
13 years	£17,394	£26,544	£25,206
14 years	£16,944	£25,615	£24,305
15 years	£16,577	£24,869	£23,580
16 years	£16,274	£24,252	£22,984
17 years	£16,023	£23,746	£22,496
18 years	£15,815	£23,326	£22,089
19 years	£15,642	£22,985	£21,758

SA 6: Changes in the treatment pathway

Changes in the treatment pathway were examined given the shortcomings in evidence available. The ICER was sensitive when it was assumed that the same treatment post-progression was used in both arms (Table 81). In clinical practice, it is expected that patients not previously treated with rituximab are more likely to receive rituximab as part of the second-line treatment, and therefore would have a greater benefit in second-line.

Table 81: SA: Varying the modelled treatment pathway (scenario analysis)

Modelled treatment pathway	R-CVP vs. CVP	R-CHOP vs. CHOP	R-MCP vs. MCP
Base case	£14,959	£21,687	£20,493
Patients receive second-line after progression only	£16,828	£21,576	£20,944
Patients on R-CVP are not re-treated with rituximab in second-line if early relapse	£15,816	£21,687	£20,493
Patients treated with an anthracycline regimen receive CHOP with or without rituximab in second-line	£14,959	£16,517	£15,261
Older patients receive with or without rituximab in second-line	£15,145	£22,251	£21,026
Combination of the three previous scenarios	£15,919	£16,750	£15,452
All patients receive R-HDT	£18,325	£20,293	£18,491
All patients receive HDT	£11,273	£12,153	£11,227
All patients receive CHOP	£14,127	£15,337	£14,146
All patients receive R-CHOP	£15,034	£16,436	£15,111

6.4.3 Comparison of the base case cost-effectiveness for the addition of rituximab to chemotherapy estimated by AG and estimated by manufacturer

Only results for the base case analysis are compared as the manufacturer⁶¹ did not present a scenario analysis allowing responders to R-chemotherapy in first-line induction to receive first-line maintenance. Greater life years were estimated by the AG, compared to the manufacturer’s estimate (Figure 48).

Figure 48: Comparison of the undiscounted life years by treatment estimated by the MS and AG

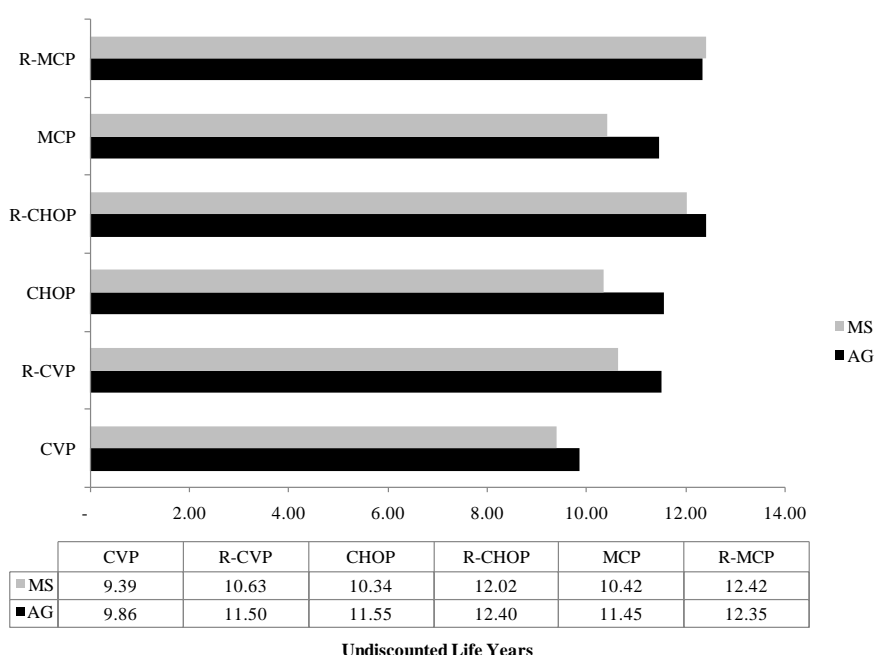

Similarly, the mean discounted QALYs were usually higher in the AG model compared to the manufacturer’s estimate (Figure 49).

On the other hand, the manufacturer’s estimate of mean discounted management and treatment costs were greater compared to the costs estimated by the AG (Figure 50).

Those differences translated into differences in the ICER estimated by the AG and included in the MS (Table 82).

Figure 49: Comparison of the discounted QALY by treatment estimated by the MS and AG

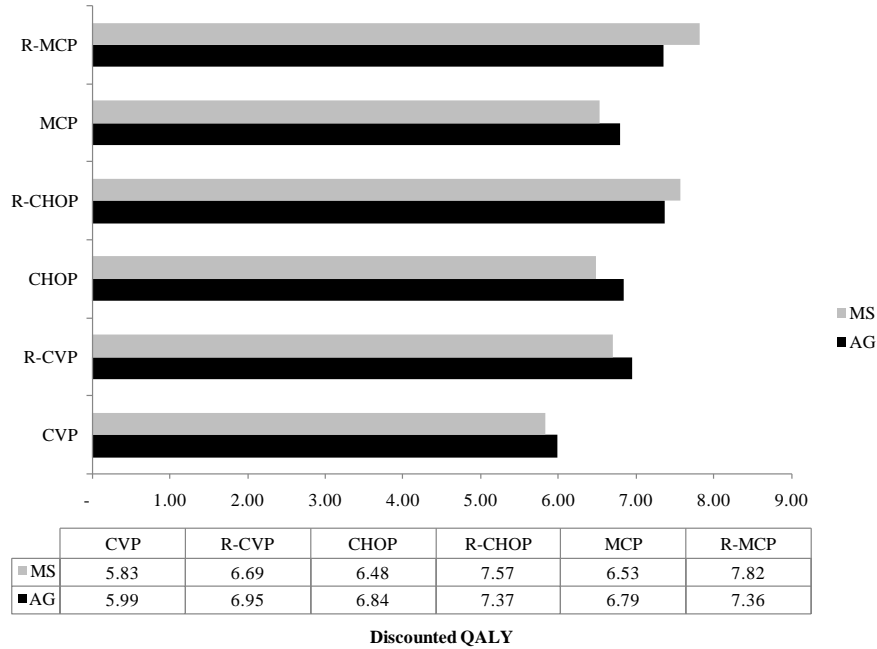

Figure 50: Comparison of discounted costs by treatment estimated by the MS and AG



Table 82: Comparison of the ICER produced by the MS and AG model

	AG model	MS model
R-CVP vs. CVP	£ 7,720	£ 1,529
R-CHOP vs. CHOP	£ 10,834	£ 5,758
R-MCP vs. MCP	£ 9,316	£ 4,861

The AG believes that differences in results are explained by the following differences in the modelling approach and assumptions used:

- 1) The MS used time to event data from Hiddemann *et al.*^{91,90} and Herold *et al.*⁹² to model the effectiveness of CHOP/ R-CHOP and MCP / R-MCP in first-line induction. However, responders received subsequent therapies (maintenance interferon and SCT) in those trials and therefore the effectiveness is likely to be confounded. The AG used a more conservative approach combining data from the M39021 trial^{95,94} but response rates from the respective trials.^{91,90,92} A separate source indicated that median PFS was about 46.7 months in FL patients treated with R-CHOP in first-line induction.⁷⁵ The modelled median PFS using the AG approach was close at about 43 months. The modelled median PFS using the MS approach was about 64 months.
- 2) There were differences in the modelled treatment pathway. The AG model provides a more detailed description of the treatment pathway in FL patients due to the flexibility in the model structure. The AG considered the use of salvage therapy (HDT) with or without rituximab in addition to ASCT in patients previously treated with an anthracycline regimen. The AG also considered the use of FC in second-line treatment for patients aged over 65 years old. The economic model included in the MS assumed that patients can only receive CHOP or R-CHOP in second-line induction. The source of effectiveness in second-line is different between the two economic evaluations.
- 3) As previously mentioned, there were some errors in the approach used by the manufacturer to model second-line treatment. This included:
 - a. The derivation of the transition probability.
 - b. The calculation of PPS
 - c. Errors in the estimation of costs in second-line.

More details are available in section 6.2.

- 4) The manufacturer fitted Exponential distributions to data in second-line from the EORTC 20981 trial.^{72,71} However the distributions did not provide a reasonable fit to the data. The AG used log-normal distribution which provided a better fit to the data.
- 5) The economic model submitted by the manufacturer missed the time spend in second-line induction treatment. PFS and OS are calculated after induction treatment in second-line. The AG model included the time spent at induction treatment. This was possible as the AG modelled the impact of maintenance more accurately by separating responders from non-responders.
- 6) The AG used a different approach to model the OS in second-line using direct KM curves for OS. The manufacturer estimated OS derived from PFS and an estimated PPS. However, there were some concerns on the approach used to derived PPS.
- 7) The AG used different utility values (PFS1: 0.805; PFS2: 0.805; PD: 0.7363) compared to the utility values included in the MS (PFS1: 0.88; PFS2: 0.79; PD: 0.62).
- 8) The model developed by the AG was also more flexible allowing to track patients over time, requiring less assumptions and therefore providing a more accurate description of outcomes over time.

6.4.4. Summary and conclusions to the cost-effectiveness section

The review of existing economic evaluations,^{112,113,114,116} the manufacturer's model and the economic evaluation carried out by the AG suggests that the addition of rituximab to chemotherapy compared with chemotherapy alone has a cost per QALY gained below £20,000 assuming that responders to R-chemotherapy do not receive first-line maintenance. The ICERs estimated by the AG for the addition of rituximab to CVP, CHOP and MCP is £7,720, £10,834 and £9,316 per QALY gained respectively assuming no first-line maintenance for responders to R-chemotherapy.

The AG presented a scenario analysis incorporating first-line maintenance in responders to R-chemotherapy in first-line induction. The ICERs estimated by the AG for the addition of rituximab to CVP, CHOP and MCP is £14,959, £21,687 and £20,493 per QALY gained respectively assuming that responders to R-chemotherapy receive first-line maintenance rituximab.

Results are not directly comparable across chemotherapies since they are selected in clinical practice with regard to factors including age, performance status and disease aggressiveness.

A range of sensitivity analyses were conducted and suggested that the ICER was sensitive to the assumptions about the time horizon (Table 59 and Table 76), the parametric extrapolation of evidence in first-line induction (Table 60 and Table 77), resistance to rituximab in previously exposed patients (Table 62 and Table 79), maximum time a patient can remain progression-free after first-line induction (Table 63 and Table 80), and the assumed treatment pathway (Table 66 and Table 81).

There were large uncertainties in the source of effectiveness in the absence of robust evidence. Therefore, the results presented should be interpreted with consideration of the assumption used.

Generalisability

There is no evidence to suggest that the results of the analysis cannot be generalised across all patients who have stage III/IV FL. However, it is noted that patients included in the trials were generally younger than those seen in clinical practice in the UK. Furthermore, despite the AG attempting to provide an accurate description of the

treatment pathway in FL patients, there were considerable uncertainties in the source of effectiveness of treatments used in second-line, notably for the effect of salvage therapy in patients previously treated with an anthracycline regimen or the effectiveness in patients previously treated with rituximab in first-line induction. This assessment is based on data involving the following chemotherapeutic agents: CVP, CHOP, MCP. It is not certain that the results can be generalised to other R-chemotherapy regimens.

Strengths and limitations of analysis

The economic evaluation has several strengths compared to previous studies. The modelled treatment pathways in our model incorporates guidance issued by NICE⁷⁰ for the treatment of FL patients and tried to provide an accurate description of the treatment pathway observed in clinical practice, whereas other models have not undertaken this in as great a detail. Notably, the economic model takes into account the fact that in clinical practice, patients previously treated with an anthracycline regimen (CHOP, MCP) would be offered alternative treatment with salvage therapy with or without rituximab in addition to ASCT if evidence of response and aged less than 65 years and are sufficiently fit. Furthermore, the model evaluates the option that patients who are not in remission (complete or partial) at the end of first-line remission induction treatment with R-chemotherapy or chemotherapy alone are likely to be offered further treatment (second-line treatment) despite the absence of progression as observed in clinical practice.

The model also uses a continuous time method over a traditional Markov process. The continuous time approach confers numerous advantages over the Markov process used in previous cost-effectiveness models, notably in terms of flexibility. The rate of progression can be easily represented by distributions that are time-dependent.

There was uncertainty regarding the effectiveness of CHOP and MCP with or without rituximab as first-line induction treatment due to the confounding effect of maintenance therapy with interferon or SCT for responders in the main trials.^{91,90,92} The AG used data from the M39021 trial^{95,94} and the response rate from the appropriate trial^{91,90,92} and showed that the median predicted PFS for R-CHOP was similar to the median PFS from a separate study.⁷⁵

A range of sensitivity analyses were also conducted. The model considered different assumptions regarding the risk of resistance and maximum time a patient can remain progression-free in first-line induction. The model also incorporated the impact of adverse events in terms of costs and impairment in quality of life. While the implementation is simplistic, the conclusion was that these had a limited impact on the results.

Finally, a scenario analysis is also presented incorporating the impact of first-line maintenance among patients responding to first-line induction with rituximab in combination with chemotherapy.

There are several limitations of the study. There were considerable uncertainties in the effectiveness in first-line induction with CHOP, R-CHOP, MCP and R-MCP. The approach used by the AG provided a reasonable fit to R-CHOP when compared to a separate source,⁷⁵ although this was considered the best approach by the AG there is still uncertainty regarding the applicability of this assumption.

Another limitation relates to the data used to model the risk of progression after second-line treatment. We used data from the EORTC 20981 trial^{72,71} to model the progression rate for patients treated in second-line with CHOP and R-CHOP with or without maintenance rituximab. However, patients were rituximab-naïve (i.e. not previously treated with rituximab) and therefore results from this study might not be applicable to patients previously treated with rituximab. Sensitivity analyses have been conducted assuming a lower effectiveness for patients previously treated with rituximab and showed that the results were highly sensitive to the assumption about the development of resistance.

Furthermore, we assumed that patients previously treated with an anthracycline regimen (CHOP, MCP) with or without rituximab would be eligible for salvage therapy with or without rituximab in addition to ASCT if there was evidence of response to chemotherapy. However, the effectiveness for patients treated with salvage therapy was extracted from a single study. Biases might have been introduced. The addition of rituximab to salvage therapy was associated with considerable benefit although it was unclear if the magnitude of the observed improvement was due to the retrospective nature of the study.¹³⁵ The study was also conducted in a pre-rituximab era, and therefore patients

were not previously exposed to rituximab. It is also unclear from the study the proportion of patients that responded to HDT, the proportion for whom the harvest was successful and the proportion of patients that received ASCT in both arms.

There were also uncertainties regarding the utility values used to describe health states in the economic model. Utility values have been extracted from a single unpublished study.^{120,119} The study included 33% patients with stage I/II FL and utility values were presented according to the degree of response to therapy. The applicability of data to populate the economic model was limited because the health states in the economic model did not match health state categories from the study. However, a range of sensitivity analyses were conducted and showed a modest impact on the ICER.

Further potential limitation is the use of log-normal distribution to represent the risk of progression in first and second-line treatment. The Log-normal distribution is non-monotonic and can have a long tail. In first-line treatment, the Log-normal provided a plausible and reasonable fit to the data and was therefore used. The ICER was very sensitive, and became more favorable to rituximab if the Gompertz distribution was used. The AG believed that the Log-normal distribution provided a more plausible long-term extrapolation (Figure 44). The use of Log-normal distribution in second-line treatment also hampered the uncertainty analysis, but this disadvantage was outweighed by the better fit of the Log-normal distribution to the data compared to other distributions.

The inclusion of first-line maintenance in responders to R-chemotherapy in first-line induction was also modelled in a simplistic manner. The treatment pathway is unknown as not part yet of clinical practice.

Finally, our results are in line with findings from previous cost-effectiveness analyses; that the addition of rituximab to chemotherapy compared with chemotherapy alone (CVP, CHOP and MCP) is likely to have a cost per QALY gained of less than £25,000.

7. ASSESSMENT OF FACTORS RELEVANT TO THE NHS AND OTHER PARTIES

The Department of Health's updated cancer plan, issued in January 2011 has outlined the government's commitment to providing and expanding patient choice of treatment by 2013/14. This includes:

- When to have treatment;
- Where to have treatment (some treatments can be given in hospital or in the community);
- Which organisation delivers treatment and care;
- Which team delivers the treatment; and
- What form of clinically appropriate treatment to have.

The paper also states that one of the NHS outcomes is to prevent people from dying prematurely, and cancer is identified as a specific improvement area. One-year and five-year cancer survival rates will be key indicators with regards to meeting this outcome.

No budget impact analysis was undertaken in this assessment report since clinical experts and the evidence suggests that rituximab is already routinely used alongside CVP in the UK. The addition of rituximab to further chemotherapies is not expected to incur significant costs. There would be minimal additional staff or infrastructure costs.

8. DISCUSSION

8.1 Statement of principal findings

Four RCTs comparing rituximab and chemotherapy versus chemotherapy alone in untreated, symptomatic stage III-IV FL patients were identified. Rituximab and chemotherapy compared with chemotherapy alone increased the likelihood of a response to treatment in all four trials, with additional toxicity of limited clinical relevance. In three trials, numbers of complete responders were significantly greater in the R-chemotherapy arm when compared with the chemotherapy alone arm. Over a follow-up period of 4 to 5 years, R-chemotherapy increased the overall survival rate compared with chemotherapy alone. Median OS values have not yet been reached in either the intervention or comparator arms in the trials, however this is not unexpected given the median survival for patients with FL is 8-10 years.²⁸ The four trials presented evidence that R-chemotherapy prolonged other clinical outcomes such as response duration, time to treatment failure, time to progression, time to next anti-lymphoma treatment, event-free survival and disease-free survival.

The ICERs for the addition of rituximab to CVP, CHOP and MCP is £7,720, £10,834 and £9,316 per QALY gained respectively when it was assumed that first-line rituximab maintenance was not used. When it was assumed that patients responding to first-line induction with R-chemotherapy receive first-line maintenance rituximab for up to 2 years, the ICERs increases to £14,959, £21,687 and £20,493 per QALY gained respectively.

Sensitivity analyses indicated that the ICER was mostly sensitive to the assumptions about the time horizon, the choice of parametric distribution to model the effectiveness in first-line induction, the maximum time a patient can remain progression-free, assumptions regarding resistance to rituximab and the modelled treatment pathway.

There were large uncertainties in the source of effectiveness in the absence of robust evidence. Therefore, the results presented should be interpreted with consideration of the assumption used.

Finally, results are not directly comparable across chemotherapies since they are selected in clinical practice with regard to factors including age, performance status and disease aggressiveness. This assessment is based on data involving the following chemotherapeutic agents: CVP, CHOP, MCP and CHVPi. It is not certain that the results can be generalised to other R-chemotherapy regimens.

8.2 Strengths and limitations of the assessment

This assessment provides a systematic review of RCTs comparing rituximab and chemotherapy with chemotherapy alone in the first-line treatment of untreated, symptomatic stage III-IV FL, using the most up-to-date data (more mature data from the GLSG-2000 trial using data from the Buske *et al.*⁹⁰ presentation at the ASH 2008 conference). We undertook comprehensive searches for trials and are confident that we have not missed any reports of RCTs or other systematic reviews of R-chemotherapy compared with chemotherapy alone.

Previous reviews have been carried out investigating the use of rituximab in FL but have included trials evaluating the use of R-chemotherapy compared with chemotherapy alone in both untreated and relapsed FL patients.^{147,148,149} These previous reviews present meta-analysed results for overall response rate, with findings in agreement with our own results i.e. R-chemotherapy improves response rates when compared to chemotherapy alone. However, the AG believes the response rates from the individual trials to be a more robust estimator of the efficacy of the specific R-chemotherapy regimens than meta-analysed response rates. This is due to problems with the validity of the meta-analyses, namely the high level of statistical heterogeneity. Ideally, this high level of heterogeneity would be explored further and explained by estimating the predictive distribution of a new study. This was not undertaken in this assessment due to resource constraints.

Data for other outcomes such as OS are compromised in three studies due to other trial treatments. Longer OS data follow-up would strengthen findings as median OS has not yet reached in any of the trials.

This assessment provides an indication of the cost-effectiveness of the addition of rituximab to CVP, CHOP and MCP alone in the UK. The results of our model are

consistent with the findings from previous cost-effectiveness analyses. The model developed by the AG extends the analysis undertaken in previous economic models in terms of a greater level of detail in the modelled treatment pathway. A wide range of assumptions have also been examined given the high uncertainty in model parameters. However, there are some limitations relating to the sources of data used for the effectiveness in first- and second-line and utility values. Assumptions have been made due to the confounding effects of other trial treatments within two of the three trials in first-line induction. Data from a single trial have been used to represent the effectiveness for patients treated with salvage therapy with or without rituximab and studies reporting the effectiveness of treatment in second-line were conducted in rituximab-naïve patients. There were large uncertainties in the source of effectiveness in the absence of robust evidence. Therefore, the results presented should be interpreted with consideration of the assumption used.

8.3 Uncertainties

There was uncertainty regarding the effectiveness of CHOP and MCP with or without rituximab as first-line induction treatment due to the confounding effect of maintenance therapy with interferon or SCT for responders in the main trials. There were also uncertainties about the inclusion of first-line maintenance in responders to R-chemotherapy in first-line induction as no guidance was issued by NICE at the time of writing of the report. Another uncertainty relates to the data used to model the risk of progression after second-line treatment. Furthermore, we also assumed that patients previously treated with an anthracycline regimen (CHOP, MCP) with or without rituximab would be eligible for salvage therapy with or with rituximab in addition to ASCT if there was evidence of response to chemotherapy. However, the effectiveness for patients treated with salvage therapy was extracted from a single study. Biases might have been introduced. Studies reporting the effectiveness of CHOP, R-CHOP and salvage therapy in second-line treatment were conducted in a pre-rituximab era, and therefore patients were not previously exposed to rituximab. Therefore, results from these studies might not be applicable to patients previously treated with rituximab.

8.4 Other relevant factors

Other relevant factors to this assessment report include:

- The outcome of the NICE appraisal assessing the use of rituximab monotherapy as a first-line maintenance treatment in FL.
- Whether bendamustine becomes licensed for use as a first-line chemotherapy in FL, and if so whether it is subsequently approved by NICE.

9. CONCLUSIONS

9.1 Implications for service provision

The addition of rituximab to CVP, CHOP and MCP is likely to be clinically effective in the first-line treatment of stage III-IV FL. The cost per QALY gained is estimated to be below £25,000 for all scenarios and is considerably lower if first-line rituximab maintenance is not assumed. The main uncertainties in terms of influencing the ICER relate to the effectiveness of rituximab re-treatment (i.e. resistance) and the effect of salvage treatment in patients previously treated with anthracycline-regimens. The context for care and the mode of delivery are very similar to the comparator therapy, thus there are no major implications that do not also apply to chemotherapy alone.

9.2 Suggested research priorities

Future research priorities include:

- Effectiveness of rituximab re-treatment (determination of resistance).
- Effectiveness of salvage treatment for patients previously treated with an anthracycline regimen.
- Effectiveness of therapies in older patients (R-FC/FC).
- Standardisation of time to event outcome measures.
- Non-confounded data for assessment of first-line treatment.
- Trials comparing an R-chemotherapy vs. another R-chemotherapy in populations that are eligible to receive both therapies.
- More studies are required assessing HRQoL in FL using the EQ-5D.

10. APPENDICES

Appendix 1: Incidence calculations and data sources for Non Hodgkin's lymphoma and Follicular Lymphoma

Table 83: Incidence of NHL and FL in England and Wales (2008)

	All	Male	Female
Total population ^a	54,454,800	26,782,800	27,672,000
NHL cases ^b	10,319	5,534	4,785
FL cases ^b	1,869	879	990
Crude incidence rate NHL per 100,000 ((NHL cases/population) x 100000)	18.9	20.7	17.3
Crude incidence rate FL per 100,000 ((FL cases/population) x 100000)	3.4	3.3	3.6

^a Mid Year Population Estimates 2008: 13/05/10¹⁵⁰ ^b Data for England from the Office for National Statistics 2008³ and data for Wales provided by the Welsh Cancer Intelligence & Surveillance Unit 2008

Table 84: Incidence of NHL and FL in England (2008)

	All	Male	Female
Total population ^a	51,464,700	25,323,500	26,141,200
NHL cases ^b	9,676	5,186	4,490
FL cases ^b	1,757	827	930
Crude incidence rate NHL per 100,000 ((NHL cases/population) x 100000)	18.8	20.5	17.2
Crude incidence rate FL per 100,000 ((FL cases/population) x 100000)	3.4	3.3	3.6

^a Mid Year Population Estimates 2008: 13/05/10¹⁵⁰ ^b Data from Office for National Statistics 2008³

Table 85: Incidence of NHL and FL in Wales (2008)

	All	Male	Female
Total population ^a	2,990,100	1,459,300	1,530,800
NHL cases ^b	643	348	295
FL cases ^b	112	52	60
Crude incidence rate NHL per 100,000 ((NHL cases/population) x 100000)	21.5	23.8	19.3
Crude incidence rate FL per 100,000 ((FL cases/population) x 100000)	3.7	3.6	3.9

^a Mid Year Population Estimates 2008: 13/05/10 ¹⁵⁰ ^b Data provided by the Welsh Cancer Intelligence & Surveillance Unit 2008

Appendix 2: Ann Arbor Staging System

The standard staging system used for FL is the same as that proposed for Hodgkin's disease at the Ann Arbor Conference in 1971. It classifies four stages of disease (Table 86).

Each stage of disease is divided into two subsets of patients according to the presence (A) or absence (B) of systematic symptoms. Fever of not evident cause, night sweats and weight loss of more than 10% of body weight are considered systemic symptoms.

Table 86: Ann Arbor staging system

Stage I	One lymph node region (I), or localised involvement of a single extralymphatic organ or site (IE).
Stage II	Two or more lymph node regions on the same side of the diaphragm (II), or localised involvement of a single associated extralymphatic organ or site and its regional nodes with or without other lymph node regions on the same side of the diaphragm (IIE).
Stage III	Lymph node regions on both sides of the diaphragm (III), that may also be accompanied by localised involvement of an extralymphatic organ or site (IIIE), by involvement of the spleen (IIIS), or both (IIIE+S).
Stage IV	Disseminated (multifocal) involvement of one or more extralymphatic organs with or without associated lymph node involvement, or isolated extralymphatic organ involvement with distant (nonregional) nodal involvement. involved organs should be designated by subscript letters (P, lung; H, liver; M, bone marrow)

Appendix 3: ECOG performance status¹⁵¹

Table 87: ECOG performance status

Grade	ECOG
0	You are fully active and more or less as you were before your illness
1	You cannot carry out heavy physical work, but can do anything else
2	You are up and about more than half the day; you can look after yourself, but are not well enough to work
3	You are in bed or sitting in a chair for more than half the day; you need some help in looking after yourself
4	You are in bed or a chair all the time and need a lot of looking after

Appendix 4: Deaths in England and Wales (including cancer and NHL deaths)

Table 88: Deaths in England and Wales (including cancer and NHL deaths)

	No. Deaths
Cancer deaths in England and Wales in 2008	137, 831
Number of deaths in England and Wales in 2008	509, 090
Number of NHL deaths in England and Wales in 2008	3978

Source: Office for National Statistics Mortality Statistics: Cause. England and Wales 2008 London TSO 2010

Appendix 5: Literature Search Strategies

Sample search for clinical effectiveness evidence using an RCT filter in MEDLINE including Medline in process (Ovid):

- 1 Cyclophosphamide.af.
- 2 Cyclophosphamide/
- 3 1 or 2
- 4 vincristine.af.
- 5 Vincristine/
- 6 4 or 5
- 7 vindesine.af.
- 8 Vindesine/
- 9 7 or 8
- 10 (prednisolone or prednisone).af.
- 11 Prednisolone/ or Prednisone/
- 12 10 or 11
- 13 doxorubicin.af.
- 14 Doxorubicin
- 15 13 or 14
- 16 (mitoxantrone or mitozantrone).af.
- 17 Mitoxantrone/
- 18 16 or 17
- 19 (cholorambucil or chlorambucil).af.
- 20 Chlorambucil/
- 21 19 or 20
- 22 fludarabine.af.
- 23 Bendamustine.af.
- 24 3 and 6 and 12
- 25 3 and 15 and 6 and 12
- 26 3 and 18 and 6 and 12
- 27 3 and 15 and 9 and 12
- 28 18 and 21 and 12
- 29 22 and 3 and 18
- 30 18 and 22

31 24 or 25 or 26 or 27 or 28 or 29 or 30 or 23

32 (CVP or CHOP or CNOP or CHVP or MCP or FCM or FM).af.

33 31 or 32

34 (rituximab or mabthera or mab thera or rituxan or IDEC-102 or IDEC-C2B8 or Rituksimabi or Rituximabum or anti-CD20 or immunotherapy or 131I-rituximab or rituximab-alliinase conjugate or monoclonal antibod\$).af.

35 Antibodies, Monoclonal/

36 33 or 34 or 35

37 (follicular lymphoma or indolent lymphoma or low grade lymphoma or lymphoma or NHL).ti,ab.

38 (Lymphoma\$ adj5 non-hodgkin\$).ti,ab.

39 (follic\$ adj5 (lymphocyte\$ or lymphoma\$)).ti,ab.

40 Lymphoma, Follicular/

41 Lymphoma, Non-Hodgkin/

42 37 or 38 or 39 or 40 or 41

43 36 and 42

44 Randomized controlled trials as Topic/

45 Randomized controlled trial/

46 Random allocation/

47 Double blind method/

48 Single blind method/

49 Clinical trial/

50 exp Clinical Trials as Topic/

51 44 or 45 or 46 or 47 or 48 or 49 or 50

52 (clinic\$ adj trial\$1).tw.

53 ((singl\$ or doubl\$ or treb\$ or tripl\$) adj (blind\$3 or mask\$3)).tw.

54 Placebos/

55 Placebo\$.tw.

56 Randomly allocated.tw.

57 (allocated adj2 random).tw.

58 52 or 53 or 54 or 55 or 56 or 57

59 51 or 58

60 Case report.tw.

61 Letter/

62 Historical article/

- 63 Review of reported cases.pt.
- 64 Review, multicase.pt.
- 65 60 or 61 or 62 or 63 or 64
- 66 59 not 65
- 67 43 and 66

In addition, searching was undertaken in October to November 2010 to identify literature on chlorambucil and fludarabine using the terms: (chlorambucil or chlorambucil).af. or (Chlorambucil/) or (fludarabine).af.) combined with population terms (steps 37-42) and RCT terms (steps 44-66 (using Boolean AND)).

Example of Economics/Cost Effectiveness Filter

- 1. Economics/
- 2. exp "Costs and Cost Analysis"/
- 3. economic value of life/
- 4. exp economics hospital/
- 5. exp economics medical/
- 6. economics nursing/
- 7. exp models economic/
- 8. Economics, Pharmaceutical/
- 9. exp "Fees and Charges"/
- 10. exp budgets/
- 11. ec.fs.
- 12. (cost or costs or costed or costly or costing\$.tw.
- 13. (economic\$ or pharmacoeconomic\$ or price\$ or pricing\$.tw.
- 14. quality adjusted life years/
- 15. (qaly or qaly\$.af.
- 16. or/1-15

Example of quality of life filter (combined with population terms only)

- 1. value of life/
- 2. quality adjusted life year/
- 3. quality adjusted life.tw
- 4. (qaly\$ or qald\$ or qale\$ or qtime\$.tw
- 5. disability adjusted life.tw

6. daly\$.tw
7. health status indicators/
8. (sf36 or sf 36 or short form 36 or shortform 36 or sf thirtysix or sf thirty six or shortform thirtysix or shortform thirty six or short form thirtysix or short form thirty six).tw
9. (sf6 or sf 6 or short form 6 or shortform 6 or sf six or sfsix or shortform six or short form six).tw
10. (sf12 or sf 12 or short form 12 or shortform 12 or sf twelve or sftwelve or shortform twelve or short form twelve).tw
11. (sf16 or sf 16 or short form 16 or shortform 16 or sf sixteen or sfsixteen or shortform sixteen or short form sixteen).tw
12. (sf20 or sf 20 or short form 20 or shortform 20 or sf twenty or sftwenty or shortform twenty or short form twenty).tw
13. (euroqol or euro qol or eq5d or eq 5d).tw
14. (hql or hqol or h qol or hrqol or hr qol).tw
15. (hye or hyes).tw
16. health\$ year\$ equivalent\$.tw
17. health utilit\$.tw
18. (hui or hui1 or hui2 or hui3).tw
19. disutili\$.tw
20. rosser.tw
21. quality of wellbeing.tw
22. quality of wellbeing.tw
23. qwb.tw
24. willingness to pay.tw
25. standard gamble\$.tw
26. time trade off.tw
27. time tradeoff.tw
28. tto.tw
29. or/1-28

Appendix 6: Response criteria for NHL⁸⁷

Complete response (CR) requires the following:

1. Complete disappearance of all detectable clinical and radiographic evidence of disease and disappearance of all disease-related symptoms if present before therapy, and normalization of those biochemical abnormalities (e.g., lactate dehydrogenase [LDH]) definitely assignable to NHL.
2. All lymph nodes and nodal masses must have regressed to normal size (≤ 1.5 cm in their greatest transverse diameter for nodes > 1.5 cm before therapy). Previously involved nodes that were 1.1 to 1.5 cm in their greatest transverse diameter before treatment must have decreased to ≤ 1 cm in their greatest transverse diameter after treatment, or by more than 75% in the sum of the products of the greatest diameters (SPD).
3. The spleen, if considered to be enlarged before therapy on the basis of a CT scan, must have regressed in size and must not be palpable on physical examination. Any macroscopic nodules in any organs detectable on imaging techniques should no longer be present. Similarly, other organs considered to be enlarged before therapy due to involvement by lymphoma, such as liver and kidneys, must have decreased in size.
4. If the bone marrow was involved by lymphoma before treatment, the infiltrate must be cleared on repeat bone marrow aspirate and biopsy of the same site. The sample on which this determination is made must be adequate (≥ 20 mm biopsy core).

Complete response/unconfirmed complete response (CRu) includes those patients who fulfil criteria 1 and 3 above, but with one or more of the following features:

1. A residual lymph node mass greater than 1.5 cm in greatest transverse diameter that has regressed by more than 75% in the SPD. Individual nodes that were previously confluent must have regressed by more than 75% in their SPD compared with the size of the original mass.
2. Indeterminate bone marrow (increased number or size of aggregates without cytologic or architectural atypical).

Partial response (PR) requires the following:

1. $\geq 50\%$ decrease in the sum of the products of the greatest diameters (SPD) of the six largest dominant nodes or nodal masses.
2. No increase in the size of the other nodes, liver, or spleen.
3. Splenic and hepatic nodules must regress by at least 50% in the SPD.
4. With the exception of splenic and hepatic nodules, involvement of other organs is considered assessable and not measurable disease.
5. Bone marrow assessment is irrelevant for determination of a PR because it is assessable and not measurable disease; however, if positive, the cell type should be specified in the report, eg, large-cell lymphoma or low-grade lymphoma (i.e., small, lymphocytic small cleaved, or mixed small and large cells).
6. No new sites of disease.

Stable disease is defined as less than a partial response but is not progressive disease

Progressive disease requires the following:

1. $\geq 50\%$ increase from nadir in the SPD of any previously identified abnormal node for PRs or non-responders.
2. Appearance of any new lesion during or at the end of therapy.

Appendix 7: List of unobtainable references

1. Agarwal, PK. Monoclonal antibody therapy for low grade follicular lymphoma: Rituximab. *Indian Journal of Hematology and Blood Transfusion* 2000; **18**:71-74.
2. Bilgir, O, Atesalan, F, Cengiz, E, and Gediz, F. The comparison of fludarabine and CHOP therapies for first line treatment in untreated low and intermediate grade non-Hodgkin lymphomas (NHL). *Blood* 2000; **96**: 234b-
3. De Acquatella, GS. Comparative study of the CHOP protocol versus COP-BLAM I. *Revista del Instituto Nacional de Cancerologia* 1993; **39**:1867-1879.
4. Herold, M. Phase III randomised study of therapy for low grade non-Hodgkin's lymphoma in patients with advanced stage: chemotherapy versus chemotherapy plus rituximab. *Onkologie* 1999; **22**: 4-6.
5. Herold, M, Fiedler, F, Pasold, R, Knauf, W, Freund, M, Naumann, R, *et al.* Efficacy and toxicity of rituximab plus mitoxantrone, chlorambucil, prednisolone (MCP) versus MCP alone in advanced indolent NHL: Interim results of a clinical phase III study of the East German Study Group Hematology/Oncology (OSHO). *Blood* 2001; **98**: 601a-
6. Li, TS. Clinical observation of CHOP regimen and CHOEP regimen in the treatment of Non-Hodgkin's lymphoma. *Chinese Journal of Cancer Prevention and Treatment* 2007; **14**: 1019-1020.
7. Lopez-Guillermo, A, Garcia-Conde, J, Alvarez-Carmona, AM, Leon, P, Maldonado, J, Alcalá, A, *et al.* Comparison of chemotherapy CHOP vs. CHOP/VIA in the treatment of aggressive non-Hodgkin's lymphoma: a randomized multicenter study of 132 patients. The PETHEMA group. Program for Study and Therapeutics of malignant hemopathies. Spanish Association of Hematology and Hemotherapy. *Medicina Clinica* 1998; **110**: 601-604.

Appendix 7: List of unobtainable references continued

8. Lopez, Guillermo A, Garcia Conde J, Alvarez-Carmona, AM, Leon, P, Maldonado, J, Alcalá, A, *et al.* Comparison between chemotherapy regimens CHOP vs CHOP/VIA for the treatment of aggressive non-Hodgkin's lymphomas. Randomized multicenter study on 132 patients: <Original> Comparacion de la quimioterapia chop frente a chop/via para el tratamiento de los linfomas no hodgkinianos agresivos: estudio multicentrico aleatorizado en 132 pacientes. *Medicina Clinica* 1998; **110**: 601-604.
9. Meusers, P, Engelhard, M, Bartels, H, Binder, T, Fülle, HH, Görg, K, *et al.* On the unfavourable prognosis of advanced centrocytic lymphoma: Results of a multicentric, randomized, therapeutic study (COP- vs. CHOP- protocol). *Klinische Wochenschrift* 1989; **67**: 98-99.
10. Moreno-Nogueira, JA, Bezwoda, WR, MacDonald, MM, Moules, IK, Akitt, LM, Posner, LE, *et al.* Phase III randomized multicenter trial comparing Cyclophosphamide, Adriamycin, Vincristin and Prednisone (CHOP) vs. Cyclophosphamide, Mitoxantrone, Vincristin and Prednisone (CNOP) in the treatment of stage II-IV diffused non-Hodgkin's lymphomas. *Oncología*. 1988;34-
11. Paul, S and Paul, S Technology evaluation: CpG-7909, Coley. *Current Opinion in Molecular Therapeutics* 2003; **5**: 553-559.
12. Prentice, AG, Johnson, SAN, Harper, P, Hewins, M, Hewins, P, Tyrrell, CJ, *et al.* A randomised, prospective trial of chlorambucil and prednisolone (CP) v mitoxantrone, chlorambucil and prednisolone (MCP) in de novo, stage II or more advanced, low-grade non- Hodgkins lymphoma (LG-NHL). *British Journal of Haematology* 1996; **93**: 74-
13. Remy, F., Ribrag, V., Mounier, N., Haioun, C., Salles, G., Golfier, J. B., Ferme, C., Briere, J., Ertault, M., Brice, P., and Gisselbrecht, C. Preliminary evaluation of efficacy and toxicity of two doses schedules of bortezomib plus R-CHOP regimen in front-line B lymphoma patients. *Haematologica, the hematology journal: abstract.book.* 2006; **91** 68-

Appendix 7: List of unobtainable references continued

14. Solal-Celigny, P, Brice, P, Brousse, N, Caspard, H, Bastion, Y, Haioun, C, *et al.* Phase II trial of fludarabine monophosphate as first-line treatment in patients with advanced follicular lymphoma: a multicenter study by the Groupe d'Etude des Lymphomes de l'Adulte. *Journal of Clinical Oncology* 1996; **14**: 514-519.
15. Wendling, P. Bendamustine outshines CHOP in advanced lymphomas. *Oncology Report* 2010;30-

Appendix 8: List of reports of four included studies

M39021 Trial

Imrie, K, Belch, A, Pettengell, R, Rueda, A, McKendrick, J, Solal, Celigny P, *et al.* CVP plus rituximab compared to CVP alone in previously untreated patients with follicular lymphoma: impact of baseline prognostic factors. *Annals of Oncology* 2005; **16 Suppl. 5**: 109-110.

Marcus, R, Imrie, K, Belch, A, Cunningham, D, Flores, E, Catalano, J, *et al.* An international multi-centre, randomized, open-label, phase III trial comparing rituximab added to CVP chemotherapy or CVP chemotherapy alone in untreated stage III/IV follicular non-Hodgkin's lymphoma. *Blood* 2003; **102**: 28a-

Marcus, R, Imrie, K, Belch, A, Cunningham, D, Flores, E, Catalano, J, *et al.* CVP chemotherapy plus rituximab compared with CVP as first-line treatment for advanced follicular lymphoma. *Blood* 15-2-2005; **105**: 1417-1423.

Marcus, R, Imrie, K, Solal-Celigny, P, Catalano, JV, Dmoszynska, A, Raposo, JC, *et al.* Phase III study of R-CVP compared with cyclophosphamide, vincristine, and prednisone alone in patients with previously untreated advanced follicular lymphoma. *Journal of Clinical Oncology* 1-10-2008; **26**: 4579-4586.

Solal-Celigny, P, Imrie, K, Belch, A, Robinson, KS, Cunningham, D, Rueda, A, *et al.* Mabthera (Rituximab) plus CVP chemotherapy for first-line treatment of stage III/IV follicular non-Hodgkin's lymphoma (NHL): Confirmed efficacy with longer follow-up. *Blood* 2005; **106**: 106A-

Appendix 8: List of reports of four included studies continued

GLSG-2000 Trial

Buske, C, Kneba, M, Forstpointner, R, Schmitz, N, Lengfelder, E, Schmits, R. *et al.* Combined immuno-chemotherapy (R-CHOP) results in significantly superior response rates and time to treatment failure in first line treatment of patients with advanced stage follicular lymphoma - Results of a prospective randomized trial of the German Low Grade Lymphoma Study Group (GLSG). *Onkologie* 2005; **28**: 37-38.

Buske, C, Kneba, M, Lengfelder, E, Pfreundschuh, M, Ludwig, WD, Graeven, U, *et al.* Front - Line Combined Immuno-Chemotherapy (R-CHOP) Significantly Improves the Time to Treatment Failure and Overall Survival in Elderly Patients with Advanced Stage Follicular Lymphoma - Results of a Prospective Randomized Trial of the German Low Grade Lymphoma Study Group (GLSG). *Blood* 2006; **108**:146-147.

Buske, C, Hoster, E, Dreyling, M, Forstpointner, R, Kneba, M, Schmitz, N, *et al.* Rituximab in Combination with CHOP in Patients with Follicular Lymphoma: Analysis of Treatment Outcome of 552 Patients Treated in a Randomized Trial of the German Low Grade Lymphoma Study Group (GLSG) after a Follow up of 58 Months [Abstract No. 2599]. *Blood* 2008; **112**

Buske, C, Kneba, M, Lengfelder, E, Pfreundschuh, M, Ludwig, WD, Graeven, U, *et al.* The first line combined immunochemotherapy R-CHOP prolongs overall survival in elderly patients with advanced stage follicular lymphoma: results of a prospective randomized trial of the German Low Grade Lymphoma Study Group (GLSG). *Onkologie* 2007; **30**: 70-

Buske, C and Hoster, E. The Follicular Lymphoma International Prognostic Index (FLIPI) separates high-risk from intermediate- or low-risk patients with advanced-stage follicular lymphoma treated front-line with rituximab and the combination of cyclophosphamide, doxorubicin, vincristine, and prednisone (R-CHOP) with respect to treatment outcome. *Blood* 2006; **108**: 1504-1508.

Appendix 8: List of reports of four included studies continued

Buske, C, Hoster, E, Dreyling, M, Hasford, J, Unterhalt, M, and Hiddemann, W. The Follicular Lymphoma International Prognostic Index (FLIPI) predicts treatment outcome in patients with advanced stage follicular lymphoma treated front-line with rituximab and the combination of cyclophosphamide, doxorubicin, vincristine and prednisone (R-CHOP). *Blood* 2005; **106**: 272A-

Hiddemann, W, Dreyling, M, Forstpointner, R, Kneba, M, Schmitz, N, Schmits, R, *et al.* Combined immuno-chemotherapy (R-CHOP) has a long lasting impact on subsequent consolidation in remission in follicular lymphoma but not in mantle cell lymphoma. *Annals of Oncology* 2005; **16 Suppl. 5** 111-

Hiddemann, W, Dreyling, MH, Forstpointer, R, Kneba, M, Woermann, B, Lengfelder, E, *et al.* Combined immuno-chemotherapy (R-CHOP) significantly improves time to treatment failure in first line therapy of follicular lymphoma - results of a prospective randomized trial of the German Low Grade Lymphoma Study Group (GLSG). *Blood* 2003; **102**: 104a-

Hiddemann, W, Kneba, M, Dreyling, M, Schmitz, N, Lengfelder, E, Schmits, R, *et al.* Frontline therapy with rituximab added to the combination of cyclophosphamide, doxorubicin, vincristine, and prednisone (CHOP) significantly improves the outcome for patients with advanced-stage follicular lymphoma compared with therapy with CHOP alone: results of a prospective randomized study of the German Low-Grade Lymphoma Study Group. *Blood* 1-12-2005; **106**: 3725-3732.

Hiddemann, W, Forstpointner, R, Kneba, M, Schmitz, N, Schmits, R, Metzner, B, *et al.* The addition of Rituximab to combination chemotherapy with CHOP has a long lasting impact on subsequent treatment in remission in follicular lymphoma but not in mantle cell lymphoma: results of two prospective randomized studies of the German Low Grade Lymphoma Study Group (GLSG). *Blood* 2004; **104**: 50a-

Appendix 8: List of reports of four included studies continued

OSHO-39 Trial

Herold, M, Haas, A, Srock, S, Naser, S, Al-Ali, K., Neubauer, A, *et al.* Addition of Rituximab to First-Line MCP (Mitoxantrone, Chlorambucil, Prednisolone) Chemotherapy Prolongs Survival in Advanced Follicular Lymphoma 4 Year Follow-Up Results of a Phase III Trial of the East German Study Group Hematology and Oncology (OSHO39). *Blood* 2006; **108** 147-

Herold, M, Dolken, G, Fiedler, F, Franke, A, Freund, M, Helbig, W, *et al.* Randomized phase III study for the treatment of advanced indolent non-Hodgkin's lymphomas (NHL) and mantle cell lymphoma: chemotherapy versus chemotherapy plus rituximab. *Annals of Hematology* 2003; **82** 77-79.

Herold, M, Pasold, R, Srock, S, Naser, S, Niederwieser, D, Neubauer, A, *et al.* Results of a Prospective Randomised Open Label Phase III Study Comparing Rituximab Plus Mitoxantrone, Chlorambucile, Prednisolone Chemotherapy (R-MCP) Versus MCP Alone in Untreated Advanced Indolent Non-Hodgkin`s Lymphoma (NHL) and Mantle-Cell-Lymphoma (MCL). *Blood* 2004; **104**: 169-

Herold, M, Haas, A, Srock, S, Naser, S, Al-Ali, KH, Neubauer, A, *et al.* Rituximab added to first-line mitoxantrone, chlorambucil, and prednisolone chemotherapy followed by interferon maintenance prolongs survival in patients with advanced follicular lymphoma: an East German Study Group Hematology and Oncology Study. *Journal of Clinical Oncology* 20-5-2007; **25**: 1986-1992.

Appendix 8: List of reports of four included studies continued

FL2000 Trial

Canioni, D, Salles, G, Mounier, N, Brousse, N, Keuppens, M, Morschhauser, F, *et al.* High numbers of tumor-associated macrophages have an adverse prognostic value that can be circumvented by rituximab in patients with follicular lymphoma enrolled onto the GELA-GOELAMS FL-2000 trial. *Journal of Clinical Oncology* 20-1-2008; **26**: 440-446.

Foussard, C, Mounier, N, Van, Hoof A, Delwail, V, Casasnovas, O, Deconinck, E, *et al.* Update of the FL2000 randomized trial combining rituximab to CHVP-Interferon in follicular lymphoma (FL) patients (pts). *Journal of Clinical Oncology : ASCO.annual meeting proceedings* 2006; **24**: 424-

Salles, G, Mounier, N, de Guibert S, Morschhauser, F, Doyen, C, Rossi, JF, *et al.* Rituximab combined with chemotherapy and interferon in follicular lymphoma patients: results of the GELA-GOELAMS FL2000 study. *Blood* 15-12-2008; **112** 4824-4831.

Salles, GA, Foussard, C, Nicolas, M, Franck, M, Chantal, D, Thierry, L, *et al.* Rituximab added to aIFN+CHVP improves the outcome of follicular lymphoma patients with a high tumor burden: first analysis of the GELA-GOELAMS FL-2000 randomized trial in 359 patients. *Blood* 2004; **104** 49a-50a.

Salles, GA, Mounier, N, de Guibert, S, Morschhauser, F, Doyen, C, Rossi, J, *et al.* Rituximab Combined with Chemotherapy and Interferon in Follicular Lymphoma Patients: Final Analysis of the GELA-GOELAMS FL2000 Study with a 5-Year Follow-Up. *Blood* 2007; **110**

Appendix 9: List of excluded studies

Excluded studies for head-to-head evidence review (n=108)

- 1.No author. A phase III trial of CHOP vs CHOP + rituximab vs CHOP + 1-131 tositumomab for newly diagnosed follicular non-Hodgkin lymphoma. *Clinical advances in hematology & oncology : H&O* 2006; **4**: 536-538.
- 2.No author.BiovaxID could prolong remission duration in follicular lymphoma patients in Phase III clinical trial. *Immunotherapy* 2009; **1**: 522-
- 3.No author.Clinical studies for patients with indolent non-Hodgkin lymphoma. *Lymphoma Today* 20-1-2000; **6**: 10-
- 4.No author. Improved survival in aggressive NHL. *European Journal of Cancer* 2001; **37**: 1326-
- 5.No author. Low-grade malignant non-Hodgkin's lymphoma: Initial treatment with the monoclonal antibody rituximab. *Deutsche Apotheker Zeitung* 2004; **144**: 57-58.
- 6.No author. Positive results announced from pivotal study of bendamustine in non-Hodgkin's lymphoma. *Oncology* 2007; **21**: 1496-
- 7.No author.Rituxan delays disease progression in indolent non-Hodgkin's lymphoma. *Oncology (Williston Park)* 2002; **16**: 1472-
- 8.No author. Rituximab for initial treatment of indolent non-Hodgkin's lymphoma. *Deutsche Apotheker Zeitung* 2004; **144**:50-51.
- 9.Alberta Heritage Foundation for Medical Research. Rituxan(R) (rituximab) (Structured abstract). *Edmonton. Alberta.Heritage.Foundation for Medical Research* 2000;

Appendix 9: List of excluded studies continued; Excluded studies for head-to-head evidence review (n=108)

10. National Horizon Scanning Centre Rituximab. (Mabthera) for non Hodgkin's lymphoma - first line maintenance therapy: horizon scanning technology briefing (Project record). *Birmingham: National Horizon.Scanning Centre.* 2009;
11. National Horizon ScanningCentre. Rituximab for 1st line low-grade non-Hodgkin's lymphoma - horizon scanning review (Brief record). *Birmingham. National Horizon.Scanning Centre.* 2004;
12. National-Institute-for-Clinical-Excellence Rituximab for aggressive non-Hodgkin's lymphoma (Structured abstract). *London: National Institute for Clinical Excellence* 2003; 22-
13. National Institute for Health and Clinical Excellence. Rituximab for the treatment of follicular lymphoma (Structured abstract). *London: National Institute for Health and Clinical Excellence* 2006; 20-
14. Ahmad, K. Conventional treatment for non-Hodgkin lymphoma for the CHOP. *Lancet Oncology* 2004; **5**: 266-
15. Al-Salman, JS. Successful treatment of gastrointestinal follicular lymphoma with rituxan and combination chemotherapy. *Medical Oncology* 2001; **18**: 277-283.
16. Anderson, T, Bender, RA, Fisher, RI, DeVita, VT, Chabner, BA, Berard, C.W, *et al.* Combination chemotherapy in non-Hodgkin's lymphoma: results of long-term followup. *Cancer Treatment Reports* 1977; **61**: 1057-1066.
17. Anlan, AY. Different chemotherapy protocols for intermediate and high grade malignant non-Hodgkin's lymphoma. *Chinese Journal of Oncology* 1997; **19**: 215-217.

Appendix 9: List of excluded studies continued; *Excluded studies for head-to-head evidence review (n=108)*

18. Aviles, AD. Combined therapy in advanced stages (III and IV) of follicular lymphoma increases the possibility of cure: Results of a large controlled clinical trial. *European Journal of Haematology* 2002; **68**: 144-149.
19. Azim, HA, Santoro, L, Bociek, RG, Gandini, S, Malek, RA, Azim, HA Jr, *et al.* High dose intensity doxorubicin in aggressive non-Hodgkin's lymphoma: a literature-based meta-analysis. *Annals of Oncology* 2010; **21**: 1064-1071.
20. Bachy EB. Long-term follow-up of patients with newly diagnosed follicular lymphoma in the prerituximab era: effect of response quality on survival--A study from the groupe d'etude des lymphomes de l'adulte. *Journal of clinical oncology: official journal of the American Society of Clinical Oncology* 2010; **28**: 822-829.
21. Badin, FH. Rituximab in the treatment of B-cell non-Hodgkin lymphoma, focus on outcomes and comparative effectiveness. *ClinicoEconomics and Outcomes Research* 2010; **2**: 37-45.
22. Baltasar, SA, Tripp, FV, Baez, ED, Rivas, S, Duque, J, Garces, O, *et al.* CNOP vs CNOP-rituximab vs rituximab alone as first-line therapy for indolent non-Hodgkin lymphoma (INHL): preliminary results. *Blood* 2003; **102**: 304b-305b.
23. Baltazar, S, Tripp, G, Baez, E, Rivas, S, Solis, L, Ignacio, G, *et al.* CNOP vs CNOP-Rituximab vs Rituximab alone as first line therapy for indolent non-Hodgkin lymphoma (INHL): preliminary diseasefree/overall survival analysis. *Hematology Journal* 2004; **5** 10-
24. Bassi, S, Mancuso, P, Gigli, F, Antoniotti, P, Bertazzoni, P, Quarna, J, *et al.* Lymphoid Subpopulations and Safety Profile in Untreated-Follicular Lymphoma Receiving Rituximab Monotherapy as Induction and Maintenance Therapy. *Blood* 2006; **108** 259-

Appendix 9: List of excluded studies continued; *Excluded studies for head-to-head evidence review (n=108)*

25. Bjorkholm, M, Andersson, T, Ahlbom, A, and Osby, E. CNOP (mitoxantrone) chemotherapy is inferior to CHOP (doxorubicin) in the treatment of patients with aggressive non-Hodgkin lymphoma (meta-analysis) (Structured abstract). *European Journal of Haematology* 2008; **80**: 477-482.
26. Boettcher, S, Pott, C, Ritgen, M, Hiddemann, W, Unterhalt, M, and Kneba, M. Evidence for Fcγ receptor IIIA-independent rituximab effector mechanisms in patients with follicular lymphoma treated with combined immuno-chemotherapy. *Blood* 2004; **104**: 170a-171a.
27. Braga, P, Carvalho, S, Gomes, M, Guerra, L, Lucio, P, Marques, H, *et al.* Health Outcomes and Costs of Rituximab in Combination with Cyclophosphamide, Vincristine and Prednisolone in the Treatment of Patients with Advanced Follicular Lymphoma in Portugal. *Blood* 2009; **114** 978-979.
28. Brandt, L, Kimby, E, Nygren, P, Glimelius, B, SBU-group. Swedish Council of Technology Assessment in Health Care. A systematic overview of chemotherapy effects in indolent non-Hodgkin's lymphoma. *Acta Oncologica* 2001; **40**: 213-223.
29. Brice, P, Salles, G, Haioun, C, Tilly, H, Le Gouill S, Foussard, C, *et al.* Long term follow up of 566 patient with follicular lymphoma included from 1986 to 1995 in the GELF86 study before rituximab era. *Haematologica, the hematology journal: abstract.book.* 2006; **91**: 383-
30. Buske, C, Hoster, E, Dreyling, MH, Forstpointner, R, Kneba, M, Schmitz, N, *et al.* Rituximab Overcomes Sex as a Strong Adverse Prognostic Factor for Treatment Outcome in Patients with Follicular Lymphoma: Analysis of Patients Treated with Rituximab/CHOP or CHOP in Randomized Trials of the German Low Grade Lymphoma Study Group (GLSG). *Blood* 2009; **114**: 1427-

Appendix 9: List of excluded studies continued; *Excluded studies for head-to-head evidence review (n=108)*

31. Canioni, D, Salles, G, Mounier, N, Brousse, N, Keuppens, M, Morchauser, F, *et al.* The Poor Prognosis Value of High Intra-Tumoral Macrophages Counts in Follicular Lymphoma Patients Requires Selection of Appropriate Cut-Off and Can Be Circumvented by Rituximab Therapy. *Blood* 2006; **108**: 247-
32. Chauvergne, J, Durand, M, Hoerni, B, Hoerni-Simon, G, Brunet, R, Lagarde, C, *et al.* Induction chemotherapy of non-Hodgkin's malignant lymphomas. Preliminary results of a controlled trial. *European Journal of Cancer (Oxford)* 1977; **13**: 399-400.
33. Cheung, MC, Haynes, AE, Meyer, RM, Stevens, A, Imrie, KR, Members of the Hematology, Disease Site Group of the Cancer Care Ontario Program in Evidence-Based Care. Rituximab in lymphoma: a systematic review and consensus practice guideline from Cancer Care Ontario. *Cancer Treatment Reviews* 2007; **33**: 161-176.
34. Cheung, MC, Meyer, R, Evans, W, Zanke, B and Imrie, KR. Rituximab for indolent lymphoma: An analysis of outcomes in a large population-wide Study. *Blood* 2003; **102**: 505b-506b.
35. Cheung, MC, Meyer, R, Hux, J, Evans, W, Nefsky, M, and Imrie, KR. Rituximab in lymphoma: A review of a province-wide initiative after one year. *Blood* 2001; **98**: 432a-
36. Chisesi, T. Chlorambucil vs chlorambucil+interferon in the therapy of low grade non-hodgkin's lymphoma. *Annals of Hematology* 1998; **77 Suppl 1**: A23-
37. Coiffier, B. First-line treatment of follicular lymphoma in the era of monoclonal antibodies. *Clinical Advances in Hematology & Oncology* 2005; **3**: 484-491.
38. Dana, BW, Dahlberg, S, Nathwani, BN, Chase, E, Coltman, C, Miller, TP, *et al.* Long-term follow-up of patients with low-grade malignant lymphomas treated with doxorubicin-based chemotherapy or chemoimmunotherapy. *Journal of Clinical Oncology* 1993; **11**: 644-651.

Appendix 9: List of excluded studies continued; *Excluded studies for head-to-head evidence review (n=108)*

39. DeGrendele, HG. Fludarabine/mitoxantrone versus CHOP followed by rituximab consolidation in chemotherapy-naive follicular lymphoma. *Clinical Lymphoma* 2003; **4** 10-15.
40. Doelken, G and Schueler, F. Rapid clearance of circulating lymphoma cells from peripheral blood of follicular lymphoma patients treated with chemotherapy and rituximab as compared to patients treated with chemotherapy alone. *European Hematology Association Website.–*; <http://www.ehaweb.org> 2002;
41. Doorduijn, JK, van der Holt, B, van der Hem, KG, van-Imhoff, G., and Kramer, MHH. Standard CHOP-chemotherapy in elderly patients with intermediate-/high-grade non-Hodgkin's lymphoma (NHL) has acceptable toxicity. *Ann Oncol* 1999; **10**: 109-
42. Dreyling, M, Forstpointner, R, Gramatzki, M, Bock, Hanel, M., Seymour, J, *et al.* Rituximab maintenance improves progression-free and overall survival rates after combined immuno-chemotherapy (R-FCM) in patients with relapsed follicular and mantle cell lymphoma: Final results of a prospective randomized trial of the German Low Grade Lymphoma Study Group (GLSG). *Journal of Clinical Oncology: ASCO.annual meeting proceedings* 2006; **24**: 422-
43. Dreyling, M, Forstpointner, R, Ludwig, W, Gramatzki, M, Boeck, H, Haenel, M, *et al.* The addition of rituximab to a fludarabine combination (R-FCM) significantly improves remission rates and overall survival in recurrent follicular as well as mantle cell lymphoma - follow up a prospective randomized trial of the german low grade lymphoma study group (GLSG). *Annals of Oncology* 2005; **16 Suppl. 5**: 110-111.
44. Fehrenbacher, L, Polikoff, JA, Hermann, R, Jhangiani, H, Bjerke, J, Loeck, D, *et al.* Rituximab Therapy after Response to R-CHOP Induction Therapy for Patients with Previously Untreated Indolent Non-Hodgkin's Lymphoma (NHL): Clinical Outcomes and Pharmacokinetics (PK). *Blood* 2007; **110**

Appendix 9: List of excluded studies continued; Excluded studies for head-to-head evidence review (n=108)

45. Feng, JJY. Meta-analysis on the efficacy and safety of R-CHOP chemotherapy for the treatment of low and moderate malignant B cell non-Hodgkin lymphoma. *Journal of Leukemia and Lymphoma* 2009; **18**: 216-219.
46. Fisher, RI. Overview of Southwest Oncology Group Clinical Trials in non-Hodgkin Lymphoma. S0016. A phase III trial of CHOP vs CHOP + rituximab vs CHOP + iodine131-labeled monoclonal anti-B1 antibody (tositumomab) for treatment of newly diagnosed follicular NHL. *Clinical Advances in Hematology & Oncology* 2005; **3**: 544-546.
47. Freedman, AS, Hamlin, PA, Neelapu, S, Nichols, C, Robertson, M, Bergier, G, *et al.* Phase III Trial of Active Immunotherapy (FavId, Id/KLH) Following Rituximab Induction Therapy: Clinical Responses in Patients (pts) with Follicular Non-Hodgkins Lymphoma (fNHL). *Blood* 2006; **108**: 780-
48. Gao, G, Liang, X, Jiang, J, Zhou, X, Huang, R, Chu, Z, *et al.* A systematic review and meta-analysis of immunochemotherapy with rituximab for B-cell non-Hodgkin's lymphoma. [Review] [29 refs]. *Acta Oncologica* 2010; **49**: 3-12.
49. Gaynor, ER, Fisher, RI, Gaynor, ER, and Fisher, RI. CHOP therapy: has shorter-course therapy had an impact on lymphomas? *Cancer Investigation* 1998; **16**: 26-32.
50. Genadieva, Stavrik S, Siljanovski, N, Stojanovik, A, Georgievski, B, Karanfilski, O, Panovska, I, *et al.* Rituximab plus CHOP is superior to standard CHOP as initial treatment for patients with previously untreated aggressive non-Hodgkin's lymphoma: a single centre experience. *10th Congress of the European Hematology Association* 2005;
51. Ghilmini, M. Adding rituximab to cyclophosphamide, vincristine and prednisone increases time to treatment failure or progression in people with untreated stage III/IV follicular lymphoma. *Cancer Treatment Reviews* 2005; **31**: 644-647.

Appendix 9: List of excluded studies continued; Excluded studies for head-to-head evidence review (n=108)

52. Ghielmini, M. Follicular lymphoma: Chemotherapy and/or antibodies? *Blood* 2006; **108**: 3235-
53. Gomez, HL, Samanez, C, Campana, F, Vera, L, Leon, J, Flores, C, *et al.* A phase II-b trial of amifostine plus CHOP vs CHOP in elderly patients with aggressive non-Hodgkin's lymphoma. *Proceedings of the American Society of Clinical Oncology* 2003; **22**: 743-
54. Hainsworth, JD, Litchy, S, Morrissey, LH, Andrews, MB, Grimaldi, M, McCarty, M, *et al.* Anthony Rituximab plus short-duration chemotherapy as first-line treatment for follicular non-Hodgkin's lymphoma: a phase II trial of the minnie pearl cancer research network. *Journal of Clinical Oncology* 1-3-2005; **23**: 1500-1506.
55. Hamlin, PA. Meta-analysis: Making sense of maintenance rituximab? Comments. *Current Oncology Reports* 2009; **11**: 329-330.
56. Hensel, M, Scheuer, L, Salwender, H, Finke, J, Buerkle, D, Duerk, HA, *et al.* How much rituximab do we need: a multicenter, randomized trial comparing 1, 3 or 6 infusions of Rituximab added to 6 cycles of CHOP chemotherapy in untreated patients with advanced follicular non-Hodgkins lymphoma (HD2000-Trial). *Blood* 2004; **104**: 230b-
57. Herold, M, Pasold, R, Srock, S, Nesper, S, Niederwieser, D, Neubauer, A, Iken, G, *et al.* Rituximab plus mitoxantrone, chlorambucil, prednisolon (R-MCP) is superior to MCP alone in advanced indolent and follicular lymphoma - results of a phase iii study (OSHO 39). *Annals of Oncology* 2005; **16 Suppl. 5** 51-52.
58. Hiddemann, W, Forstpointner, R, Fiedler, F, Gramatzski, M, Dorken, B, Illiger, H, *et al.* Combined immunochemotherapy (R-FCM) is superior to chemotherapy (FCM) alone in recurrent indolent lymphoma - results of a prospective randomized comparison. *European Journal of Cancer* 2001; **37**: S46-

Appendix 9: List of excluded studies continued; *Excluded studies for head-to-head evidence review (n=108)*

59. Hiddemann, W, Hoster, E, Buske, C, Dreyling, M, Kneba, M, Hallek, M, *et al.* Rituximab Is the Essential Treatment Modality That Underlies the Significant Improvement in Short and Long Term Outcome of Patients with Advanced Stage Follicular Lymphoma - A 10 Year Analysis of GLSG Trials. *Blood* 2006; **108**: 147-
60. Hieke, K. and Herold, M. Adding rituximab to standard chemotherapy appears dominant vs. chemotherapy alone in advanced stage NHL - Interim results from a randomized clinical trial (RCT). *Value in Health* 2005; **8**: A38-A38.
61. Hieke, K, Pasold, R, Nesper, S, Neiderwieser, D, Neubauer, A, Doelken, G, *et al.* Cost evaluation of Rituximab plus MCP vs. MCP alone in advanced stage indolent non-Hodgkin's-lymphoma based on a randomized controlled multicenter trial. *Blood* 2004; **104**: 28a-29a.
62. Hirt, C, Schueler, F, Kiefer, T, Schwenke, C, Herold, M, and Doelken, G. High molecular remission rate in follicular lymphoma patients after combination therapy with Rituximab and chemotherapy: Clinical significance of quantitative monitoring of minimal residual disease. *Onkologie* 2005; **28**: 144-
63. Hirt, C, Schuler, F, Kiefer, T, Schwenke, C, Haas, A, Niederwieser, D, *et al.* Rapid and sustained clearance of circulating lymphoma cells after chemotherapy plus rituximab: clinical significance of quantitative t(14;18) PCR monitoring in advanced stage follicular lymphoma patients. *British Journal of Haematology* 2008; **141**: 631-640.
64. Hochster, HS, Weller, E, Ryan, T, Habermann, TM, Gascoyne, R, *et al.* Results of E1496: A phase III trial of CVP with or without maintenance rituximab in advanced indolent lymphoma (NHL). *Journal of Clinical Oncology : ASCO.annual meeting proceedings* 2004; **22**: 556-
65. Hunault-Berger, MI. Intensive therapies in follicular non-Hodgkin lymphomas. *Blood* 2002; **100**: 1141-1152.

Appendix 9: List of excluded studies continued; Excluded studies for head-to-head evidence review (n=108)

66. Itoh, K, Igarashi, T, Ogura, M, Morishima, Y, Hotta, T, Kinoshita, A, *et al.* Randomized phase II study of concurrent and sequential combinations of rituximab (R) plus CHOP (R-CHOP) in untreated indolent B-NHL: 7-year follow-up results [abstract no.8616]. *Journal of Clinical Oncology: ASCO.annual meeting proceedings* 2008; **26** 482-
67. Jaeger, G, Brezinschek, R, Neumeister, P, and Linkesch, W. CHOP-induction and anti-CD20-(mAb-Thera™) consolidation as first-line treatment of follicular lymphoma. Preliminary data of a phase II study. *Onkologie* 2000; **23**: 151-
68. Kouroukis, CT, Browman, GP, Esmail, R, and Meyer, RM. Chemotherapy for older patients with newly diagnosed, advanced-stage, aggressive-histology non-Hodgkin lymphoma: a systematic review (Structured abstract). *Annals of Internal Medicine* 2002; **136**: 144-152.
69. Ladetto, M, De, Marco F., Benedetti, F, Vitolo, U, Patti, C, Rambaldi, A, *et al.* Clinical and Molecular Results of the Multicenter Randomized GITMO-III Trial in Poor Risk Follicular Lymphoma (FL) at Diagnosis: Rituximab-Supplemented High-Dose Sequential Chemotherapy (R-HDS) Is Superior to CHOP-R in Molecular Remissions Rate, EFS and PFS. *Blood* 2006; **108**: 101-
70. Ladetto, M, Ricca, I, Benedetti, F, Liberati, M, Vitolo, U, Musso, M, *et al.* Multicenter prospective randomized GITMO trial comparing high dose sequential chemotherapy with autografting and CHOP both supplemented with rituximab in poor-risk follicular lymphoma: early evaluation on treatment feasibility and response rate. *Bone Marrow Transplantation* 2003; **31**: S7-S8
71. Ladetto, M, Ricca, I, Benedetti, F, Vitolo, U, Patti, C, Rambaldi, A, *et al.* Rituximab-supplemented high-dose sequential chemotherapy (HDS) has superior response rate and event-free survival (EFS) compared to R-CHOP in poor risk follicular lymphoma (FL) at diagnosis: results from a multicenter randomized GITMO trial. *Blood* 2005; **106**

Appendix 9: List of excluded studies continued; Excluded studies for head-to-head evidence review (n=108)

72. Lenz, G. Moderate increase of secondary hematologic malignancies after myeloablative radiochemotherapy and autologous stem-cell transplantation in patients with indolent lymphoma: results of a prospective randomized trial of the German Low Grade Lymphoma Study Group. *Journal of clinical oncology : official journal of the American Society of Clinical Oncology* 2004; **22**: 4926-4933.
73. Leonard, JPR. New Agents in Development for Non-Hodgkin's Lymphoma. *Seminars in Hematology* 2007; **44**: S18-S21.
74. Maloney, DG, Press, OW, Braziel, RM, Unger, JM, LeBlanc, ML, Grogan, T, *et al.* A phase II trial of CHOP followed by rituximab chimeric monoclonal anti-CD20 antibody for treatment of newly diagnosed follicular non-Hodgkin's lymphoma: SWOG 9800. *Blood* 2001; **98**: 843a-
75. Maloney, DG, Pender-Smith, B, Unger, JM, Braziel, RM, Radich, J, Press, OW, *et al.* Fc(gamma) receptor polymorphisms do not influence progression free survival (PFS) of follicular NHL patients treated with chop followed by rituximab (SWOG 9800). *Blood* 2004; **104**: 170A-
76. Marcus, R. Use of Rituximab in Patients with Follicular Lymphoma. *Clinical Oncology* 2007; **19**: 38-49.
77. Martinelli, G, Schmitz, S, Hess, U, Okkinga, E, Stupp, R, Taverna, C, *et al.* Long-term follow-up of patients with follicular lymphoma receiving single-agent rituximab at two different schedules in trial SAKK 35/98. *Journal of Clinical Oncology* 2010; **28**: 4480-4484.
78. Matsumoto, K, Maeda, Y, Ono, Y, Tamiya, T, Furuta, T and Ohmoto, T. Primary malignant lymphoma in the central nervous system treated with high dose methotrexate (MTX)-CHOP (M-CHOP). *No Shinkei Geka - Neurological Surgery* 1998; **26**: 889-895.

Appendix 9: List of excluded studies continued; Excluded studies for head-to-head evidence review (n=108)

79. McClanahan, F, Hielscher, T, Rieger, M, Hensel, M, Bentz, M, Schmidt-Wolf, I, *et al.* How Much Rituximab Do We Need: A Multicenter, Randomized Trial Comparing 1, 3 or 6 Infusions of Rituximab Combined with 6 Cycles of CHOP Chemotherapy in Untreated Patients with Advanced Follicular Lymphoma (HD2000-Trial). *Blood* 2009; **114**: 1051-1052.
80. Meckenstock, G, Kobbe, G, Kronenwett, R, Martin, S, Viardot, A, Aul, C, *et al.* First line treatment of advanced follicular lymphoma comparing fludarabine/mitoxantrone and high-dose chemotherapy, each combined with CD20-antibody rituximab. *Onkologie* 2005; **28**: 153-
81. Meckenstock, G, Martin, S, Kobbe, G, Moller, P, Bentz, M, Aul, C, *et al.* Firstline treatment of advanced follicular lymphoma comparing fludarabine / Mitoxantrone and high-dose chemotherapy, each combined with CD20-antibody Rituximab. *Onkologie* 2003; **26**: 174-
82. Meckenstock, G, Martin, S, Kobbe, G, Moller, P, Bentz, M, Rhagavachar, A, *et al.* Fludarabine/mitoxantrone versus high-dose chemotherapy, each combined with CD20-antibody rituximab, as first-line treatment of advanced follicular lymphoma. *Onkologie* 2002; **25**: 60-
83. Mori, M, Murai, Y, Suzuki, K, Nonaka, Y, Sato, H, Tomiyama, J, *et al.* Study of optimal CHOP dose ranges for elderly patients with non-Hodgkin's lymphoma. *Rinsho Ketsueki - Japanese Journal of Clinical Hematology* 1999; **40**: 199-204.
84. Nagai, H, Yano, T, Watanabe, T, Uike, N, Okamura, S, Hanada, S, *et al.* Remission induction therapy containing rituximab markedly improved the outcome of untreated mature B cell lymphoma. *British Journal of Haematology* 2008; **143**: 672-680.
85. Oborilova, AS. Fludarabine in treatment of follicular lymphoma. *Klinicka Onkologie* 2003; **16**: 203-210.

Appendix 9: List of excluded studies continued; Excluded studies for head-to-head evidence review (n=108)

86. Psyrri, A, Dimopoulos, MA, Fountzilias, G, Tsatalas, C, Anagnostopoulos, A, Papageorgiou, S, *et al.* Treatment of low-grade non-Hodgkin lymphomas with fludarabine and mitoxantrone followed by rituximab maintenance: Results of a phase II study. *Blood* 2006; **108**: 261B-262B.
87. Rambaldi, A, Lazzari, M, Manzoni, C, Carlotti, E, Arcaini, L, Baccarani, M, *et al.* Monitoring of minimal residual disease after CHOP and rituximab in previously untreated patients with follicular lymphoma. *Blood* 1-2-2002; **99**: 856-862.
88. Rivas, Vera S, Baez, E, Sobrevilla, CP, Baltazar, S, Tripp, F, Vela, J, *et al.* Is First Line Single Agent Rituximab the Best Treatment for Indolent Non-Hodgkin's Lymphoma? Update of a Multicentric Study Comparing Rituximab vs CNOP vs Rituximab Plus CNOP. *Blood* 2005; **106**: 684-
89. Schulz, H, Bohlius, JF, Trelle, S, Skoetz, N, Reiser, M, Kober, T, *et al.* Immunochemotherapy with rituximab and overall survival in patients with indolent or mantle cell lymphoma: a systematic review and meta-analysis. *JNCI: Journal of the National Cancer Institute* 200; **99**: 706-714.
90. Shen, T, Guan, ZZ, Shen, Z, She, Y, and Zhu, J. Results of multicentre phase IV study of rituximab in combination with CHOP chemotherapy in patients with previously untreated non-Hodgkin's lymphoma. *Blood* 2004; **104**: 239B-240B.
91. Shen, Z, Li, J, Wang, A, and Chen, Y. Survival benefits of patients with non-Hodgkin's lymphoma treated with rituximab combined with chemotherapy. *Blood* 2004; **104**: 240B-
92. Siddhartha, G and Vijay P. R-CHOP versus R-CVP in the treatment of follicular lymphoma: A meta-analysis and critical appraisal of current literature. *Journal of Hematology and Oncology* 2009; **2**: 14

Appendix 9: List of excluded studies continued; *Excluded studies for head-to-head evidence review (n=108)*

93. Sonneveld, P, van Putten W, Biesma, D, Holte, H, van-Marwijk, KM, Kramer, MHH, *et al.* Phase III Trial of 2-Weekly CHOP with Rituximab for Aggressive B-Cell Non-Hodgkins Lymphoma in Elderly Patients. *Blood* 2006; **108**: 66-
94. Stone, JM, Page, FJ, Laidlaw, CR, Cooper, I, Stone, JM, Page, FJ, *et al.* Selection of patients for randomised trials: a study based on the MACOP-B vs CHOP in NHL study. *Australian & New Zealand Journal of Medicine* 1994; **24**: 536-540.
95. Taskinen, M, Karjalainen-Lindsberg, ML, Leppa, S, Taskinen, M, Karjalainen-Lindsberg, ML, and Leppa, S. Prognostic influence of tumor-infiltrating mast cells in patients with follicular lymphoma treated with rituximab and CHOP. *Blood* 1-5-2008; **111**: 4664-4667.
96. Tripp, F, Baez, E, Avila, E, Baltazar, S, Garces, O, Reyes, G, *et al.* Efficacy and Safety of Rituximab+CHOP in IR and Maintenance Therapy with Rituximab vs Observation in De Novo Aggressive Non-Hodgkin Lymphoma. *Blood* 2007; **110**: 193b-194b.
97. Vose, JML. Long-term update of a phase II study of rituximab in combination with CHOP chemotherapy in patients with previously untreated, aggressive non-Hodgkin's lymphoma. *Leukemia and Lymphoma* 2005; **46**: 1569-1573.
98. Vose, JM, Link, BK, Grossbard, ML, Czuczman, M, Grillo-Lopez, A, Benyunes, M, *et al.* Long Term Follow-Up of a Phase II Study of Rituximab in Combination with CHOP Chemotherapy in Patients with Previously Untreated Aggressive Non-Hodgkin's Lymphoma (NHL). *Blood* 2002; **100**

Appendix 9: List of excluded studies continued; *Excluded studies for head-to-head evidence review (n=108)*

99. Walewski, J, Kraszewska, E, Mioduszewska, O, Romejko-Jarosinska, J, Hellmann, A, Czyz, J, *et al.* Rituximab (Mabthera, Rituxan) in patients with recurrent indolent lymphoma: evaluation of safety and efficacy in a multicenter study. *Medical Oncology* 2001; **18**: 141-148.
100. Wilson, WH. R-CHOP strikes again with survival benefit in follicular lymphoma. *Blood* 2005; **106**: 3678-3679.
101. Winter, JNW. Prognostic significance of Bcl-6 protein expression in DLBCL treated with CHOP or R-CHOP: A prospective correlative study. *Blood* 2006; **107**: 4207-4213.
102. Winter, JN, Weller, E, Horning, SJ, Krajewska, M, Variakojis, D, Habermann, TM, *et al.* Rituximab (R) alters the prognostic indicator profile in diffuse aggressive non-Hodgkin lymphomas. *Blood* 2003; **102**: 101a-102a.
103. Wunderlich, A, Kloess, M, Reiser, M, Rudolph, C, Truemper, L, Bittner, S, *et al.* Practicability and acute haematological toxicity of 2- and 3-weekly CHOP and CHOEP chemotherapy for aggressive non-Hodgkin's lymphoma: results from the NHL-B trial of the German High-Grade Non-Hodgkin's Lymphoma Study Group (DSHNHL). *Annals of Oncology* 2003; **14**: 881-893.
104. Xie, CL. Efficacy of Rituximab combined with CHOP for B cell non-Hodgkin's lymphoma. *Chinese Journal of Clinical Oncology* 2009; **36**: 1398-1400.
105. Xu, ZQ. Clinical study of Rituximab combined with CHOP in treatment of B cell non-Hodgkin's lymphoma. *Chinese Journal of Cancer Prevention and Treatment* 2007; **14**: 1589-1590.
106. Zinzani, PL, Pulsoni, A, Perrotti, A, Soverini, S, Zaja, F, De, Renzo A, *et al.* Fludarabine plus mitoxantrone with and without rituximab versus CHOP with and without rituximab as front-line treatment for patients with follicular lymphoma. *Journal of Clinical Oncology* 1-7-2004; **22**: 2654-2661.

Appendix 9: List of excluded studies continued; Excluded studies for head-to-head evidence review (n=108)

107. Zinzani, PL and Bosis, A. Multicenter Randomized Trial of Fludarabine and Mitoxantrone (FM) Plus Rituximab Versus CHOP Plus Rituximab as First-Line Treatment in Patients with Follicular Lymphoma (FL). *Blood* 2002; **100**: Abstract-
108. Zinzani, PL. A randomized trial of Fludarabine and Mitoxantrone plus Rituximab versus CHOP plus Rituximab as first-line treatment in patients with follicular lymphoma. *Blood* 2001; **98**: 842a-

Appendix 9: List of excluded studies continued

Excluded studies that could potentially inform a network meta-analysis (n=104)

1. Al-Ismail, SA, Whittaker, JA, Gough, J, Al-Ismail, SA, Whittaker, JA, and Gough, J. Combination chemotherapy including epirubicin for the management of non-Hodgkin's lymphoma. *European Journal of Cancer & Clinical Oncology* 1987; **23**: 1379-1384.
2. Alliot, C. CHOP versus CHOP plus granulocyte colony-stimulating factor in elderly patients with aggressive non-Hodgkin's lymphoma. *Journal of clinical oncology: official journal of the American Society of Clinical Oncology* 2005; **23**: 4797-4799.
3. Alliot, C. Fludarabine versus cyclophosphamide, vincristine, and prednisone in recurrent low-grade lymphomas. *Journal of clinical oncology: official journal of the American Society of Clinical Oncology* 2003; **21**: 2626-2627.
4. Andersen, J, Thorling, K, Bentzen, SM, Brincker, H, Christensen, BE, Pedersen, M, *et al.* Phase III trial of cyclophosphamide, doxorubicin, vincristine and prednisone (CHOP) versus cisplatin, etoposide, bleomycin and prednisone (CisEBP) for the treatment of advanced non-Hodgkin's lymphoma of high grade malignancy. The Danish Lymphoma Study Group. *Acta Oncologica* 1990; **29**: 995-999.
5. Aurer, I, Eghbali, H, Raemackers, JM, Khaled, HM, Van Glabbeke, M, Baila, L, *et al.* (R)CHOP Versus (R)CHOP: A Randomized Phase II Study of Gemcitabine Combined with (R)CHOP in Untreated Aggressive Non-Hodgkin's Lymphoma - EORTC Lymphoma Group Protocol 20021. *Blood* 2008; **112**: 1234-1235.
6. Ben, Shahar M, Gepstein, R, Haim, N, and Polliack, A. Phase III trial of a combination of chlorambucil (L) and prednisone (P) with or without mitoxantrone (M) in advanced low grade non-Hodgkin's lymphoma (NHL) and CLL. *Proceedings of the American Society of Clinical Oncology* 1998; **17**: 20a-

Appendix 9: List of excluded studies continued; excluded studies that could potentially inform a network meta-analysis (n=104)

7. Bessell, EM, Burton, A, Haynes, AP, Glaholm, J, Child, JA, Cullen, MH, Davies, *et al.* A randomised multicentre trial of modified CHOP versus MCOP in patients aged 65 years and over with aggressive non-Hodgkin's lymphoma. *Annals of Oncology* 2003; **14**: 258-267.
8. Bezwoda, W, Rastogi, R, Erazo Valla, A, Diaz-Maqueo, J, Pavlovsky, S, Morioka, H, *et al.* Long-term results of a multicentre randomised, comparative phase III trial of CHOP versus CNOP regimens in patients with intermediate- and high-grade non-Hodgkin's lymphomas. *European Journal of Cancer* 1995; **31A**: 903-911.
9. Bezwoda, WR and Rastogi, RB. A randomized comparative study of cyclophosphamide, vincristine, doxorubicin, and prednisolone and cyclophosphamide, vincristine, mitoxantrone, and prednisolone regimens in the treatment of intermediate- and high-grade lymphoma with 8 years' follow-up. *Seminars in Hematology* 1994; **31**: 3-
10. Bishop, JF, Wiernik, PH, Wesley, MN, Kaplan, RS, Diggs, CH, Barcos, MP, *et al.* A Randomized Trial of High Dose Cyclophosphamide Vincristine and Prednisone plus or minus Doxorubicin CVP Versus CAVP with Long-Term Follow-Up in Advanced Non-Hodgkin'S Lymphoma. *Leukemia (Basingstoke)* 1987; **1**: 508-513.
11. Bishop, JF, Wiernik, PH, Kaplan, RS. High dose cyclophosphamide, vincristine and prednisone plus or minus adriamycin (CAVP vs CVP) in advanced poorly differentiated lymphocytic and lymphocytic-histiocytic non-Hodgkin's lymphoma (NHL): A randomized trial. *Proceeds of the American Association of Cancer Research.* 1981;C-727.

Appendix 9: List of excluded studies continued; excluded studies that could potentially inform a network meta-analysis (n=104)

12. Bruno, S, Corrado, C, Santarelli, MT, Garay, G, Somoza, N, Tezanos, Pinto M, *et al.* Randomized trial of cyclophosphamide versus cyclophosphamide, vincristine and prednisone in low grade lymphoma. *Proceedings of the American Society of Clinical Oncology* 1988; **7** 243, Abstract-
13. Burchardt, CA, Brugger, W, Maschmeyer, G, Kofahl-Krause, D, Fischer, L, Roller, Fritz, B, *et al.* Peripheral Blood Stem Cell Mobilization After Bendamustine Containing Chemotherapy in Indolent Lymphomas Is Possible. Results From the Phase III Study of B-R Vs. CHOP-R (NHL 1-2003 trial) of the StiL (Study group indolent Lymphomas, Germany). *Blood* 2009; **114**: 1048-1049.
14. Burton, C, Linch, D, Hoskin, P, Milligan, D, Dyer, MJ, Hancock, B, *et al.* A phase III trial comparing CHOP to PMitCEBO with or without G-CSF in patients aged 60 plus with aggressive non-Hodgkin's lymphoma. *British Journal of Cancer* 27-3-2006; **94**: 806-813.
15. Burton, C, Cunningham, D, Qian, W, Maclellann, K, and Hancock, B. A phase III trial comparing CHOP to PMITCEBO with or without G-CSF in patients aged 60 plus with aggressive non-hodgkin's lymphoma. *Annals of Oncology* 2005; **16 Suppl. 5**: 103-
16. Burton, C, Smith, P, Vaughan-Hudson, G, Qian, W, Hoskin, P, Cunningham, D. Comparison of CHOP versus CIOP in good prognosis younger patients with histologically aggressive non-Hodgkin lymphoma. *British Journal of Haematology* 2005; **130**: 536-541.
17. Carrato, A, Koziner, B, Wong, G, Lowenthal, DA, Chapman, D, Little, C, *et al.* Randomized comparison of CHOP vs BLEO-CHOP for the treatment of non-Hodgkins lymphoma: a five year update. *Proceedings of the American Society of Clinical Oncology* 1987; **6**: 198, Abstract-

Appendix 9: List of excluded studies continued; excluded studies that could potentially inform a network meta-analysis (n=104)

18. Chen, SF, Chen, GQ, Lao, Y, Zhang, JZ, Li, ZQ, *et al.* Clinical comparison of ProMACE-CytaBOM and CHOP regimen for the treatment of Non-Hodgkin's lymphoma. *Chinese Journal of Cancer* 1997; **16**: 438-440.
19. Cooper, IA, Wolf, MM, Robertson, TI, Fox, RM, Matthews, JP, Stone, JM, *et al.* Randomized comparison of MACOP-B with CHOP in patients with intermediate-grade non-Hodgkin's lymphoma. The Australian and New Zealand Lymphoma Group. *Journal of Clinical Oncology* 1994; **12**: 769-778.
20. Dell'Olio, M, Bodenizza, C, Carella, AM, Falcone, A, Greco, MM, La, Sala A, *et al.* R-COMP vs. R-CHOP in the treatment in newly diagnosed elderly patients with aggressive non-hodgkins lymphoma. *Haematologica, the hematology journal: abstract.book.* 2007; **92**: 471-
21. Diggs, CH and Wiernik, PH. Cyclophosphamide, vinristine, and prednisone (CVP) vs. cyclophosphamide, adriamycin, vincristine and prednisone (CAVP) for disseminated non-hodgkin's lymphomas. *Proceedings of the American Association for Cancer Research* 1977; **mar 16-17** 288-
22. Ding, Y, Huabang, D, Yuhua, F, Xiaoyu, F, Zhijiu, L, and Yuhua, K. A randomised study of comparison of regimen ABVD vs CHOP in patients with intermediate and high grade lymphoma. *Ann Oncol* 1999; **10**: 105-
23. Economopoulos, T, Dimopoulos, MA, Mellou, S, Pavlidis, N, Samantas, E, Nicolaides, C, *et al.* Treatment of intermediate- and high-grade non-Hodgkin's lymphoma using CEOP versus CNOP. *European Journal of Haematology* 2002; **68**: 135-143.
24. Ezzat, A, Ibrahim, E, Stuart, R, Ajarim, D, Bazarbashi, S, El-Foudeh, M, *et al.* Adding high-dose tamoxifen to CHOP does not influence response or survival in aggressive non-Hodgkin's lymphoma: An interim analysis of a randomized phase III trial. *Medical Oncology (Basingstoke)* 2000; **17** 39-46.

Appendix 9: List of excluded studies continued; excluded studies that could potentially inform a network meta-analysis (n=104)

25. Fisher, RI, Gaynor, ER, Dahlberg, S, Oken, MM, Grogan, TM, Mize, EM, *et al.* A phase III comparison of CHOP vs. m-BACOD vs. ProMACE-CytaBOM vs. MACOP-B in patients with intermediate- or high-grade non-Hodgkin's lymphoma: results of SWOG-8516 (Intergroup 0067), the National High-Priority Lymphoma Study. *Annals of Oncology* 1994; **5 Suppl 2**: 91-95.
26. Fisher, RI, Gaynor, ER, Dahlberg, S, Oken, MM, Grogan, TM, Mize, EM, *et al.* Comparison of a standard regimen (CHOP) with three intensive chemotherapy regimens for advanced non-Hodgkin's lymphoma. *New England Journal of Medicine* 8-4-1993; **328**: 1002-1006.
27. Fisher, RI. Cyclophosphamide, doxorubicin, vincristine, and prednisone versus intensive chemotherapy in non-Hodgkin's lymphoma. *Cancer Chemotherapy & Pharmacology* 1997; **40 Suppl**: S42-S46.
28. Foussard, C, Deconinck, E, Desablens, B, Ghandouri, C, Milpied, N, Vilque, JP, *et al.* A randomized trial of fludarabine, mitoxantrone (FM) versus doxorubicin, cyclophosphamide, vindesine, prednisone (CHEP) as first line treatment in patients with advanced low-grade non- Hodgkin lymphoma (LG-NHL): A multicenter study by Goelams Group. *Blood* 1998; **92**: 316a-
29. Foussard, C, Deconinck, E, Desablens, B, Ghandour, C, Lucas, V, and Pignon, B. Fludarabine - mitoxantrone combination: preliminary results of a randomized trial versus m-chef as first line treatment in patients with advanced low-grade non-Hodgkin lymphoma by goelams group. *Ann Oncol* 1999; **10**: 127-
30. Foussard, C, Deconninck, E, Desablens, B, Maisonneuve, H, Gressin, R, Pignon, B, *et al.* Improved response after fludarabine, mitoxantrone (FM) in first line treatment of patients with advanced low-grade non-Hodgkin's lymphoma (LG-LNH) as compared to prednisone, doxorubicin, vindesine, cyclophosphamide (CHEP): a randomized trial by Goelams Group. *Proceedings of the American Society of Clinical Oncology* 2001; **20 (Pt 1)**: 280a, Abstract-

Appendix 9: List of excluded studies continued; excluded studies that could potentially inform a network meta-analysis (n=104)

31. Foussard, C, Colombat, P, Maisonneuve, H, Berthou, C, Gressin, R, Rousselet, MC, *et al.* Long-term follow-up of a randomized trial of fludarabine-mitoxantrone, compared with cyclophosphamide, doxorubicin, vindesine, prednisone (CHVP), as first-line treatment of elderly patients with advanced, low-grade non-Hodgkin's lymphoma before the era of monoclonal antibodies. *Annals of Oncology* 2005; **16**: 466-472.
32. Fridrik, MA, Hausmaninger, H, Lang, A, Greil, R, Drach, J, Lin, W, I Sequential alternating chemotherapy with cyclophosphamide, epirubicin, vincristine, prednisolon, ifosfamide, etoposide, methotrexate, dexamethasone, and filgrastim (CEOP/IMVP-Dexa) vs. standard cyclophosphamide, vincristine, doxorubicin, prednisolon (CHOP) in untreated aggressive non-Hodgkin's lymphoma. A prospective randomised study (NHL-5) of the AGMT. *Blood* 2002; **100**
33. Fridrik, MA, Hausmaninger, H, Greil, R, Lang, A, Drach, J, Fortelny, A, *et al.* Cyclophosphamide, doxorubicin, vincristine, prednisolone (CHOP) versus cyclophosphamide, epirubicin, vincristine, prednisolone, ifosfamide, VP-16, methotrexate, dexamethasone (CEOP/IMVP-Dexa) for aggressive non-Hodgkin's lymphoma. A multicenter randomized trial of the Austrian working party medical oncology. *Blood* 1999; **94**: 261b-
34. Gams, RA, Rainey, M, Dandy, M, Bartolucci, AA, Silberman, H, Omura, G, *et al.* Phase III study of BCOP v CHOP in unfavorable categories of malignant lymphoma: a Southeastern Cancer Study Group trial. *Journal of Clinical Oncology* 1985; **3**: 1188-1195.
35. Hagberg, H, Bjorkholm, M, Glimelius, B, Lindemalm, C, Mellstedt, H, Killander, A, *et al.* CHOP vs MEV for the treatment of non-Hodgkin's lymphoma of unfavourable histopathology: a randomized clinical trial. *European Journal of Cancer & Clinical Oncology* 1985; **21**: 175-179.

Appendix 9: List of excluded studies continued; excluded studies that could potentially inform a network meta-analysis (n=104)

36. Hagenbeek, A, Eghbali, H, Monfardini, S, Resegotti, E, Hoskin, J, deWolf, Peeters C, *et al.* Fludarabine compared with CVP chemotherapy in newly diagnosed patients with stages III and IV low grade malignant non- Hodgkin's lymphoma. Final analysis of a prospective randomized phase III intergroup study in 381 patients. *Blood* 2001; **98**: 843a-
37. Hagenbeek, A, Eghbali, H, Monfardini, S, Resegotti, E, Hoskin, J, deWolf, Peeters C, *et al.* Fludarabine versus conventional CVP chemotherapy in newly diagnosed patients with stages III and IV low grade malignant non-Hodgkin's lymphoma. Preliminary results from a prospective, randomized phase III clinical trial in 381 patients. *Blood* 1998; **92**: 315a, Abstract-
38. Hagenbeek, A, Eghbali, H, Monfardini, S, Vitolo, U, Hoskin, PJ, de Wolf-Peeters, C, *et al.* Phase III intergroup study of fludarabine phosphate compared with cyclophosphamide, vincristine, and prednisone chemotherapy in newly diagnosed patients with stage III and IV low-grade malignant Non-Hodgkin's lymphoma. *Journal of Clinical Oncology* 1-4-2006; **24**: 1590-1596.
39. Hou, M, Li, L, Qiu, M, Yan, X, Zhu, J, Gou, HF, *et al.* Clinical randomized comparative trial of ProMACE-CytaBOM regimen and CHOP regimen in treating non-Hodgkin's lymphoma. *Aizheng* 2005; **24**: 461-464.
40. Hou, MY. Comparison of short-term effect of ProMACE-CytaBOM regimen with CHOP regimen for non-Hodgkin's lymphoma. *Chinese Journal of Clinical Oncology* 1995; **22**: 857-859.
41. Jerkeman, M, Anderson, H, Cavallin-Stahl, E, Dictor, M, Hagberg, H, Johnson, A, *et al.* CHOP versus MACOP-B in aggressive lymphoma--a Nordic Lymphoma Group randomised trial. *Annals of Oncology* 1999; **10**: 1079-1086.

Appendix 9: List of excluded studies continued; excluded studies that could potentially inform a network meta-analysis (n=104)

42. Kimby, E, Bjorkholm, M, Gahrton, G, Glimelius, B, Hagberg, H, Johansson, B, *et al.* Chlorambucil/prednisone vs. CHOP in symptomatic low-grade non-Hodgkin's lymphomas: a randomized trial from the Lymphoma Group of Central Sweden. *Annals of Oncology* 1994; **5 Suppl 2**: 67-71.
43. Kitamura, K, Mori, M, Masuda, M, Hotta, T, Miyazaki, T, Miura, R, *et al.* Improved survival with THP-COP compared to CHOP for non-Hodgkin's lymphoma in the elderly: a Japanese cooperative study. *Blood* 1994; **84**: 164a-
44. Klasa, R, Meyer, R, Shustik, C, Sawka, C, Smith, A, Grenier, JF, *et al.* Fludarabine Versus CVP in Previously Treated Patients with Progressive Low Grade Non-Hodgkin's Lymphomas (lg-NHL). *Proceedings of the American Society of Clinical Oncology* 1999; **18**: 9a-
45. Koenig, HJ and Mueller, G. A Randomized Trial of Chop Versus Ceop e Equals Epirubicin in Intermediate and High Grade Non-Hodgkin'S Lymphoma Nhl. *Journal of Cancer Research and Clinical Oncology* 1990; **116**: 613-
46. Koppler, H, Pfluger, KH, Eschenbach, I, Pfab, R, Bruntsch, U, Zeller, W, *et al.* Sequential versus alternating chemotherapy for high-grade non-Hodgkin's lymphomas: preliminary results of a phase III multicentre trial. *Onkologie* 1990; **13**: 28-32.
47. Koppler, H, Pfluger, KH, Eschenbach, I, Pfab, R, Birkmann, J, Zeller, W, *et al.* Sequential versus alternating chemotherapy for high grade non-Hodgkin's lymphomas: a randomized multicentre trial. *Hematological Oncology* 1991; **9**: 217-223.
48. Koppler, H. Pfluger, KH. CHOEP versus alternating hCHOP/IVEP for high grade non-Hodgkin's lymphomas: A randomized multicentre trial. *Onkologie* 1991; **14**: 181-184.

Appendix 9: List of excluded studies continued; excluded studies that could potentially inform a network meta-analysis (n=104)

49. Kruglova, G. V. and Finogenova, I. A. COP vs CHOP in aggressive non-hodgkin's lymphomas (NHL). *Annals of Hematology* 1998; **77 Suppl 1** A30-
50. Liang, R, Todd, D, Chan, TK, Chiu, E, Lie, A, Ho, F, *et al.* COPP chemotherapy for elderly patients with intermediate and high grade non-Hodgkin's lymphoma. *Hematological Oncology* 1993; **11**: 43-50.
51. Lorusso, V, Palmieri, G, Bianco, AR, Abate, G, Catalano, G, De, Vita F, *et al.* CEOP-B/VIMB vs. promace-CytaBOM in the treatment of intermediate or high grade non-Hodgkin's lymphoma: A randomised multicenter study of Southern Italy Cooperative Group. *International Journal of Oncology* 2000; **16**: 149-154.
52. Luminari S. The GISL HD2000 trial comparing ABVD with BEACOPP and with CEC as initial treatment of patients with advanced Hodgkin lymphoma. *American Journal of Hematology/ Oncology* 2009; **8**
53. Meusers, P, Engelhard, M, Bartels, H, Binder, T, Fulle, HH, Gorg, K, *et al.* Multicenter randomized therapeutic study for advanced centrocytic lymphoma: COP vs. CHOP regimen. *Blut* 1988; **57**: 222-
54. Meusers, P, Engelhard, M, Bartels, H, Binder, T, Fulle, HH, Gorg, K, *et al.* Multicentre randomized therapeutic trial for advanced centrocytic lymphoma: anthracycline does not improve the prognosis. *Hematological Oncology* 1989; **7**: 365-380.
55. Meyer, RM, Benger, A, Findlay, B, Friedman, E, Haines, P, Leber, B, *et al.* A randomized phase II comparison of CHOP vs CHOP + etoposide (CHOPE) in patients with intermediate grade lymphoma. *Proceedings of the American Society of Clinical Oncology* 1998; **17**: 32a, Abstract-

Appendix 9: List of excluded studies continued; excluded studies that could potentially inform a network meta-analysis (n=104)

56. Meyer, RM, Benger, A, Browman, G, Bryant, D, Frank, G, Leber, B, *et al.* Randomized phase II comparison of standard CHOP with weekly 'CHOP' for elderly patients with intermediate grade lymphoma (IGL). *Proceedings of the American Society of Clinical Oncology* 1994; **13**: 369, Abstract-
57. Meyer, RM, Browman, GP, Samosh, ML, Benger, AM, Bryant-Lukosius, D, Wilson, WE, *et al.* Randomized phase II comparison of standard CHOP with weekly CHOP in elderly patients with non-Hodgkin's lymphoma. *Journal of Clinical Oncology* 1995; **13**: 2386-2393.
58. Miller, TP, Dalberg, S, Cassady, JR, Spier, C, Grogan, TM, Carlin, S *et al.* Superiority of a brief course of chop plus radiotherapy (RT) over chop alone in localized unfavorable non-Hodgkin's lymphoma (NHL) is seen in lowest risk subgroups: a southwest oncology group study. *Annals of Oncology* 1996; **7**: 23-
59. Mishima, Y, Sugimura, N, Matsumoto-Mishima, Y, Terui, Y, Takeuchi, K, Asai, S, Ennishi, D, *et al.* An imaging-based rapid evaluation method for complement-dependent cytotoxicity discriminated clinical response to rituximab-containing chemotherapy. *Clinical Cancer Research* 15-5-2009; **15**: 3624-3632.
60. Monfardini, S, Tancini, G, DeLena, M. Cyclophosphamide, vincristine, and prednisone (CVP) versus adriamycin, bleomycin, and prednisone (ABP) in stage IV non Hodgkin's lymphomas. *Medical Pediatric Oncology* 1977; **3**: 67-74.
61. Montoto S. High clinical and molecular response rates with fludarabine, cyclophosphamide and mitoxantrone in previously untreated patients with advanced stage follicular lymphoma. *Haematologica* 2008; **93**: 207-214.
62. Montoto, S, Lopez-Guillermo, A, Domingo-Domenech, E, Ribera, J, Altes, A, Estany, C, Besalduch, J, *et al.* High clinical and molecular response rates with fludarabine, cyclophosphamide and mitoxantrone (FCM) in previously untreated patients with advanced stage follicular lymphoma (FL). *Blood* 2003; **102**: 401a-

Appendix 9: List of excluded studies continued; excluded studies that could potentially inform a network meta-analysis (n=104)

63. Mori, M, Kitamura, K, Masuda, M, Hotta, T, Miyazaki, T, Miura, AB, *et al.* Long-term results of a multicenter randomized, comparative trial of modified CHOP versus THP-COP versus THP-COPE regimens in elderly patients with non-Hodgkin's lymphoma. *International Journal of Hematology* 2005; **81**: 246-254.
64. Mori, M. and Miura, AB. Study of optimal CHOP dose ranges for elderly patients with non-Hodgkin's lymphoma. [*Rinsho ketsueki*] *The Japanese journal of clinical hematology* 1999; **40**:199-204.
65. Morishima, Y, Ogura, M, Itoh, K, Ohtsu, T, Sasaki, Y, Kasai, M, *et al.* A Randomized Comparison of PBSC Mobilization By Lenograstim During Biweekly CHOP Vs High-CHOP in Pts with Non-Hodgkin's Lymphoma. *Proceedings of the American Society of Clinical Oncology* 1999; **18**: 63a-
66. Nickenig, C, Buske, C, Dreyling, M, Kneba, M, Lengfelder, E, *et al.* Immune chemotherapy (R-CHOP) significantly improve the time until therapy failure as well as total survival in older patients with follicular lymphoma - GLSG study results. *Medizinische Klinik* 2007; **102**: 35-
67. Nickenig, C, Dreyling, M, Hoster, E, Pfreundschuh, M, Truemper, L, Reiser, M, *et al.* Anthracyclin-containing regimens (CHOP) achieve higher response rates but not superior overall survival in follicular and mantle cell lymphoma. *Annals of Oncology* 2005; **16 Suppl. 5**: 151-152.
68. Niitsu, N, and Umeda, M. Prognostic factors of follicular lymphoma treated with combination chemotherapy. *Rinsho Ketsueki - Japanese Journal of Clinical Hematology* 1997; **38**: 496-504.
69. Ogura, M, Morishima, Y, Kagami, Y, Watanabe, T, Itoh, K, Igarashi, T, *et al.* Randomized phase II study of concurrent and sequential rituximab and CHOP chemotherapy in untreated indolent B-cell lymphoma. *Cancer Science* 2006; **97**: 305-312.

Appendix 9: List of excluded studies continued; excluded studies that could potentially inform a network meta-analysis (n=104)

70. Ohnoshi, T, Hayashi, K, Ueno, K, Murashima, M, Tada, A, Mizuta, J, *et al.* Chemotherapy of aggressive non-Hodgkin's lymphomas: a retrospective analysis of a single institution. *Rinsho Ketsueki - Japanese Journal of Clinical Hematology* 1989; **30**: 1201-1204.
71. Oriuchi, N, Higuchi, T, Endo, K, Tsukamoto, N, Matsuda, H, Kuji, I, *et al.* Application of 18F-FDG PET for the assessment of early response to the treatment and prognosis of patients. *Kaku Igaku - Japanese Journal of Nuclear Medicine* 2009; **46**: 96-99.
72. Pan, D, Chen, P, and Cai, XJ. The studies on clinical efficacy of biweekly regimen of CHOP chemotherapy on non-Hodgkin's malignant lymphoma. *Chinese Journal of Clinical Oncology* 2006; **33**: 455-457.
73. Pan, D, Qin, J, Farber, C, O'Brien, J, Filippa, D, Portlock, CS, *et al.* CHOP with high dose cyclophosphamide consolidation versus CHOP alone as initial therapy for advanced stage, indolent non-Hodgkin's lymphomas. *Leukemia & Lymphoma* 2003; **44**: 967-971.
74. Pan, D, Qin, J, Farber, C, Zelenetz, AD, O'Brien, JP, and Portlock, CS. Intensification with high dose cyclophosphamide following CHOP offers no significant benefit compared to CHOP alone as initial therapy for indolent non-Hodgkin's lymphomas. *Proceedings of the American Society of Clinical Oncology* 2001; **20 (Pt 2)**: 226b, Abstract-
75. Pavlovsky, S, Milone, G, Somoza, N, Corrado, C, Magnasco, H, Cerutti, I, *et al.* Comparative study of 1st generation versus 2d generation (CAVPE) combinations in intermediate and high-grade lymphomas]. [Spanish]. *Sangre* 1993; **38**: 17-23.

Appendix 9: List of excluded studies continued; excluded studies that could potentially inform a network meta-analysis (n=104)

76. Pavlovsky, S, Erazo, A, Diaz-Maqueo, JC, Somoza, N, Cervantes, G, Garay, G, *et al.* A randomized trial of CHOP versus CNOP (N=Mitoxantrone) in intermediate and high grade non-Hodgkin's lymphoma. *Proceedings of the American Society of Clinical Oncology* 1989; **8**: 258, Abstract-
77. Pavlovsky, S, Santarelli, MT, Erazo, A, Diaz Maqueo, JC, Somoza, N, Lluesma, Gonalons M, *et al.* Results of a randomized study of previously-untreated intermediate and high grade lymphoma using CHOP versus CNOP. *Annals of Oncology* 1992; **3**: 205-209.
78. Portlock, CS, Rosenberg, SA, Glatstein, E, and Kaplan, HS. Stage IV non-hodgkin's lymphoma: a prospective trial comparing CVP (Cyclophosphamide, Vincristine, Prednisone) alone vs. split course CVP with total lymphoid irradiation (CVP-RAD) vs. continuous single alkylating agent (SA). *Proceedings of the American Association for Cancer Research* 1975; **16**: 266-266.
79. Prentice, AG, Johnson, SA, Harper, P, Ewings, M, Ewings, P, Tyrell, CJ, *et al.* A trial of chlorambucil and prednisolone vs. mitoxantrone, chlorambucil and prednisolone in non-Hodgkin's lymphoma (NHL) of working formulation (WF) classes A to F at stage II or greater. *Blood* 1997; **90**: 249a, Abstract-
80. Rolski, J, Koralewski, P, Pawlicki, M, Rolski, J, Koralewski, P, and Pawlicki, M. Comparison of effectiveness of adriamycin and epirubicin administered in the CHOP protocol to patients with malignant non-hodgkin's lymphoma. *Wiadomosci Lekarskie* 1993; **46**: 356-359.
81. Sonneveld, P, de, Ridder M, van der Lelie, H, Nieuwenhuis, K, Schouten, H, Mulder, A, *et al.* Comparison of doxorubicin and mitoxantrone in the treatment of elderly patients with advanced diffuse non-Hodgkin's lymphoma using CHOP versus CNOP chemotherapy. *Journal of Clinical Oncology* 1995; **13**: 2530-2539.

Appendix 9: List of excluded studies continued; excluded studies that could potentially inform a network meta-analysis (n=104)

82. Sonneveld, P, van der Lelie, H, Nieuwenhuis, K, Schouten, H, de, Rider M, Hop, W, *et al.* Phase III study of doxorubicin (CHOP) compared with mitoxantrone (CNOP) in elderly patients with intermediate/high risk non-Hodgkin's lymphoma. *Blood* 1994; **84**: 384a-
83. Stuart, R, Ezzat, A, Ibrahim, E, Ranginwala, M, Ajarim, D, El, Foudeh M, *et al.* CHOP versus CHOP+High -dose tamoxifen in the management of aggressive non-Hodgkin's lymphoma: Interim analysis of a prospective randomized trial. *Proceedings of the American Society of Clinical Oncology* 1999; **18**: 38a-
84. Takagi, T, Sampi, K, Sawada, U, Sakai, C, Oguro, M, Takagi, T, *et al.* A comparative study of CHOP versus MEVP (mitoxantrone, etoposide, vindesine, prednisolone) therapy for intermediate-grade and high-grade non-Hodgkin's lymphoma: a prospective randomized study. *International Journal of Hematology* 1993; **57**: 67-71.
85. Thyss, A, Sotto, JJ, Mari, V, Rossi, JF, Fabbro, M, and Maisonneuve, H. Aggressive non-Hodgkin's lymphoma in the elderly: Early results of a phase III study comparing CHOP-like regimen and MEMID. *Annals of Oncology* 1999; **10**: 59-
86. Thyss, A, Gressin, R, Foussard, C, Lepeu, G, Fabbro, M, Delwail, V, *et al.* Phase III study of CHOP-like regimen compared with MEMID in elderly patients with aggressive Hodgkin's lymphoma: Preliminary results. *Blood* 1998; **92**: 622a, Abstract-
87. Thyss, A, Sotto, JJ, Mari, V, Rossi, JF, Fabbro, M, and Maisonneuve, H. Progressive non-Hodgkin's lymphoma in the elderly: Early results of a phase III study comparing CHOP-like regimen and MEMID. *Ann Oncol* 1999; **10**: 59-

Appendix 9: List of excluded studies continued; excluded studies that could potentially inform a network meta-analysis (n=104)

88. Tilly, H, Lepage, E, Coiffier, B, Blanc, M, Herbrecht, R, Bosly, A, *et al.* A randomized comparison of ACVBP and CHOP in the treatment of advanced aggressive non-Hodgkin's lymphoma: the LNH93-5 study. *Blood* 2000; **96**: 832a-
89. Tilly, H, Mounier, N, Coiffier, B, Bouabdallah, R, Casasnovas, O, Reman, O, *et al.* ACVBP regimen vs. CHOP in the treatment of advanced aggressive non-Hodgkin's lymphoma (NHL). Results of the LNH93-5 study with a median follow-up of 5 years. *Proceedings of the American Society of Clinical Oncology* 2003; **22**: 574-
90. Tilly, H, Lepage, E, Coiffier, B, Blanc, M, Herbrecht, R, Bosly, A, *et al.* Intensive conventional chemotherapy (ACVBP regimen) compared with standard CHOP for poor-prognosis aggressive non-Hodgkin lymphoma. *Blood* 15-12-2003; **102**: 4284-4289.
91. Tilly, H, Mounier, N, Coiffier, B, Casasnovas, O, Boubdallah, R, Reman, O, Bosly, *et al.* Superiority of intensive conventional chemotherapy ACVBP over CHOP in advanced aggressive non-Hodgkin's lymphoma (NHL). Results of the CELA study LNH93-5 with a median follow-up of 5 years. *8th Congress of the European Hematology Association* 2003;
92. Tirelli, U, Van, Glabbeke M, Teodorovic, I, Rosti, G, Zagonel, V, and Monfardini, S. A randomized comparison of CHOP vs. a combination of VP16, mitoxantrone and prednimustine (VMP) in patients (PTS)> 70 years of age with intermediate-high grade NHL. *Tumori* 1996; **82**: 59-
93. Tirelli, U, Van, Glabbeke M, Teodorovic, I, Thomas, J, Bron, D, Kluin-Nelemans, JC, *et al.* A randomized comparison of CHOP vs a new combination of VP-16, mitoxantrone and prednimustine (VMP) in patients (pts) more than 70 years of age with intermediate-high grade NHL: an EORTC lymphoma group study. *Proceedings of the American Society of Clinical Oncology* 1995; **14**: 398, Abstract-

Appendix 9: List of excluded studies continued; excluded studies that could potentially inform a network meta-analysis (n=104)

94. Tirelli, U and Carbone A. 20-year experience on malignant lymphomas in patients aged 70 and older at a single institute. *Critical Reviews in Oncology/Hematology* 2001; **37**: 153-158.
95. Tsurumi, H, Yamada, T, Sawada, M, Kasahara, S, Kanemura, N, Kojima, Y, *et al.* Biweekly CHOP or THP-COP regimens in the treatment of newly diagnosed aggressive non-Hodgkin's lymphoma. A comparison of doxorubicin and pirarubicin: a randomized phase II study. *Journal of Cancer Research & Clinical Oncology* 2004; **130**: 107-113.
96. Urasinski, I, Zdziarska, B, Wichert, K, Zuk, E, Urasinski, I, Zdziarska, B, *et al.* Results of treating patients with highly malignant non-Hodgkin's lymphomas; comparison of treatment efficacy with CHOP and CBVPM-AVBP. *Polski Merkuriusz Lekarski* 1998; **4**: 137-139.
97. Uyl-de-Groot, CA, Hagenbeek, A, Verdonck, LF, Löwenberg, B, and Rutten, FF. Cost-effectiveness of ABMT in comparison with CHOP chemotherapy in patients with intermediate- and high-grade malignant non-Hodgkin's lymphoma (NHL). *Bone Marrow Transplantation* 1995; **16**: 463-470.
98. Vaughan, HG. BNLI trial of CHOP vs chlorambucil in aggressive low grade stage III/IV non Hodgkin's lymphoma: a preliminary report. *British Journal of Haematology* 1990; **74**: 13-
99. Vose, JM, Link, BK, Grossbard, ML, Czuczman, M, Grillo-Lopez, A, Gilman, P, *et al.* Phase II study of rituximab in combination with chop chemotherapy in patients with previously untreated, aggressive non-Hodgkin's lymphoma. *Journal of Clinical Oncology* 15-1-2001; **19**: 389-397.

Appendix 9: List of excluded studies continued; excluded studies that could potentially inform a network meta-analysis (n=104)

100. Wolf, M, Matthews, JP, Stone, J, Cooper, IA, Robertson, TI, Fox, RM, *et al.* Long-term survival advantage of MACOP-B over CHOP in intermediate-grade non-Hodgkin's lymphoma. The Australian and New Zealand Lymphoma Group. *Annals of Oncology* 1997; **8 Suppl 1**: 71-75.
101. Wolf, M, Cooper, I, Robertson, T, Fox, R, Matthews, J, and Stone, J. Randomized comparison of macop-b with chop for intermediate-grade non-Hodgkin's lymphoma: long-term follow-up. *Annals of Oncology* 1996; **7**: 24-
102. Woof, M, Matthews, JP, Stone, J, Grigg, A and Benson, W. Confirmation of a long-term survival advantage of MACOP-B over CHOP in intermediate-grade non-Hodgkin's lymphoma (NHL). *Ann Oncol* 1999; **10**: 59-
103. Zinzani, PL, Tura, S, Cajozzo, A, Leone, G, Papa.G, Gentilini, P, Rossi, G, *et al.* Phase III comparative trial adriamycin vs idarubicin (CHOP vs CIOP) in the treatment of intermediate grade non-Hodgkin's lymphoma. *Blood* 1992; **80**: 476a-
104. Zinzani, PL, Martelli, M, Storti, S, Musso, M, Cantonetti, M, Leone, G, *et al.* Phase III comparative trial using CHOP vs CIOP in the treatment of advanced intermediate-grade non-Hodgkin's lymphoma. *Leukemia & Lymphoma* 1995; **19**: 329-335.

Appendix 10: List of excluded studies that met criteria for a network meta-analysis

1. Coiffier, B, Stamatoullas, A, Belanger, C, Bouabdallah, R, Haioun, C, Neidhardt, EM, *et al.* CHVP + interferon alpha 2b treatment is associated with a longer survival than fludarabine alone in elderly patients with high risk follicular lymphoma: A randomized study from the GELA. *Blood* 1998; **92**: 486a, Abstract-
2. Coiffier, B, Neidhardt-Berard, EM, Tilly, H, Belanger, C, Bouabdallah, R, Haioun, C, *et al.* Fludarabine alone compared to CHVP plus interferon in elderly patients with follicular lymphoma and adverse prognostic parameters: A GELA study. *Annals of Oncology* 1999; **10**: 1191-1197.
3. Nickenig, C, Dreyling, MH, Schiegnitz, E, Pfreundschuh, M, Truemper, LH, Reiser, M, *et al.* CHOP Improves Response Rates but Not Overall Survival in Follicular and Mantle Cell Lymphoma (MCL)- Results of a Randomized Trial of the German Low Grade Lymphoma Study Group (GLSG). *Blood* 2004; **104**: 176-
4. Nickenig, C, Dreyling, M, Schiegnitz, E, Wandt, H, Huber, C, Trumper, L, *et al.* CHOP significantly improves overall response and overall survival in patients with advanced follicular lymphoma - results of a randomized trial of the German Low Grade Lymphoma Study Group (GLSG). *Onkologie* 2004; **27**: 15-
5. Nickenig, C, Dreyling, M, Hoster, E, Pfreundschuh, M, Trumper, L, Reiser, M, *et al.* Combined cyclophosphamide, vincristine, doxorubicin, and prednisone (CHOP) improves response rates but not survival and has lower hematologic toxicity compared with combined mitoxantrone, chlorambucil, and prednisone (MCP) in follicular and mantle cell lymphomas: results of a prospective randomized trial of the German Low-Grade Lymphoma Study Group. *Cancer* 1-9-2006; **107**: 1014-1022.

Appendix 10: List of excluded studies that met criteria for a network meta-analysis

6. Rummel, MJ, von, Gruenhagen U, Niederle, N, Ballo, H, Weidmann, E, Welslau, M, *et al.* Bendamustine Plus Rituximab Versus CHOP Plus Rituximab in the First-Line-Treatment of Patients with Follicular, Indolent and Mantle Cell Lymphomas: Results of a Randomized Phase III Study of the Study Group Indolent Lymphomas (StiL) [Abstract No. 2596]. *Blood* 2008; **112**: 900-
7. Rummel, MJ, Niederle, N, Maschmeyer, G, Banat, A, von Gruenhagen, U, Losem, C, *et al.* Bendamustine Plus Rituximab Is Superior in Respect of Progression Free Survival and CR Rate When Compared to CHOP Plus Rituximab as First-Line Treatment of Patients with Advanced Follicular, Indolent, and Mantle Cell Lymphomas: Final Results of a Randomized Phase III Study of the StiL (Study Group Indolent Lymphomas, Germany). *Blood* 2009; **114**: 168-169.

Appendix 11: Data extraction tables

M39021 trial (Marcus et al)^{95,94}

METHODS

Allocation: randomised (1:1 ratio using stratification according to International Prognostic Index (IPI) scores)

Blinding: open label

Setting: multicentre, 47 centres in Australia, Belgium, Brazil, Canada, France, Israel, Poland, Portugal, Spain, Switzerland, and the UK

Treatment duration: treated every 21 days for a maximum of 8 cycles

Follow up: median 53 months (no range reported)

Design: Parallel group, Intention-to-treat

Power calculation: Yes

PARTICIPANTS

Diagnosis: Follicular lymphoma

N=322 (1 CVP enrolled patient withdrew consent.)

Age: Median age R-CVP 52 years; CVP = 53 years

Gender: Males: 174, Females: 148

Inclusion criteria: patients 18 years or older with untreated CD20 + follicular lymphoma (National Cancer Institute [NCI] Working Formulation Groups B, C, D; WHO follicular lymphoma Grades 1-3 confirmed by lymph node biopsy. All patients had to have stage III or IV disease, a performance status of 0 to 2 according to Eastern Clinical Oncology Group (ECOG) criteria, a life expectancy of more than 3 months, and a need for therapy in the opinion of the participating clinician.

Exclusion criteria: Patients were ineligible if there was evidence of histologic transformation to high-grade or diffuse large B-cell lymphoma, central nervous system involvement, or a history of severe cardiac disease or previous malignancy other than in situ carcinoma of the cervix and basal cell carcinoma of the skin. Patients were also excluded if they had impaired renal or hepatic function.

Enrolment details and diagnosis

322 patients enrolled between 2000-2002 from 47 sites in Australia, Belgium, Brazil, Canada, France, Israel, Poland, Portugal, Spain, Switzerland, and the UK. Patients diagnosed with CD20+ follicular lymphoma (NCI) and were previously untreated.

INTERVENTIONS

1. CVP; dose 750 mg/m² cyclophosphamide intravenously on day 1; 1.4 mg/m² of vincristine, up to a maximal dose of 2 mg intravenously, on day 1; and 40 mg/m² of prednisone per day orally on days 1 to 5. N= 159.

2. Rituximab + CVP; dose 375 mg/m² of rituximab intravenously on day 1 of 8 therapy cycles. N=162.

Patients in both groups were treated every 21 days for a maximum of 8 cycles.

MAINTENANCE THERAPY

None

Evaluation of response and definitions of outcomes

Tumour response and progression was determined using the guidelines by Cheson *et al.* Stable disease after cycle 4 was considered a “treatment failure” event by the independent DSMC, who believed that patients with stable disease would be more likely to continue the same therapy in the R-CVP arm but would be more likely to start a new treatment in the CVP arm; these patients were withdrawn from treatment.

Time to progression (TTP), defined as the interval between randomization and progression, relapse after response, or death from any cause.

Time to treatment failure (TTF), defined as the time between randomization and any one of the following events: progressive disease (PD), relapse after response, institution of new antilymphoma treatment (NLT); stable disease after cycle 4 (SD4), or death by any cause.

Disease-free survival defined as the time between complete response and relapse or death (not specified)

Time to next antilymphoma treatment defined as the time between randomisation and the date of next/new treatment or death (not specified)

Response duration defined as the time between response and relapse or death (not specified). Overall survival was defined as the time from randomisation to the date of death by any cause

Baseline characteristics of M39021 trial^{95,94}

Baseline characteristics	R-CVP, Number (%) (n=162)	CVP, Number (%) (n=159)
Age/Gender		
Median	52	53
Younger than 40 y	24 (15)	16 (10)
40-50 y	48 (30)	45 (28)
51-60 y	49 (30)	54 (34)
60 y or older	41 (25)	44 (28)
Male sex	88 (54)	85 (54)
Performance status (ECOG score)^a		
0	93 (57%)	90 (57%)
1	65 (40%)	60 (38%)
Greater than 1	4 (3%)	8 (5%)
Not evaluable/missing	0	1 (1%)
Histology class (IWF classification): Local review		
A (CLL)	0	2 (1%)
B (FL grade 1)	59 (36%)	53 (33%)

Baseline characteristics	R-CVP, Number (%) (n=162)	CVP, Number (%) (n=159)
C (FL grade 2)	87(54%)	89 (56%)
D (FL grade 3)	14 (9)	13 (8%)
Other	1 (1%)	1 (1%)
Not evaluable/missing	1 (1%)	1 (1%)
Histology class (IWF classification): Central review		
A (CLL)	0	2 (1%)
B (FL grade 1)	38 (2%3)	46 (29%)
C (FL grade 2)	82 (51%)	69 (43%)
D (FL grade 3)	19 (12%)	19 (12%)
Other	7 (4)	6 (2)
Not evaluable /missing	16 (10)	17 (11)
Stage (Ann Arbor)		
II	2 (1%)	2 (1%)
III-1 ^b	5 (3%)	4 (3%)
III-2 ^c	40 (25%)	41 (26%)
IV	114 (70%)	112 (70%)
Not evaluable/missing	1 (1%)	0
International Prognostic Index score^d		

Baseline characteristics	R-CVP, Number (%) (n=162)	CVP, Number (%) (n=159)
0	1 (1%)	1 (1%)
1	72 (44%)	69 (43%)
2	57 (35%)	57 (36%)
3	19 (12%)	21 (13%)
4	2 (1%)	3 (2%)
Not evaluable/missing	11 (7%)	8 (5%)
Follicular Lymphoma International Prognostic Index score^d		
0-2	80 (49%)	75 (47%)
3-5	71 (44%)	75 (47%)
Not evaluable/missing	11 (7%)	9 (6%)
1 or more B symptoms	65 (40%)	51 (32%)
Bulky disease ^f	63 (39%)	73 (46%)
Bone marrow involvement	103 (64%)	102 (64%)
1 or more extranodal sites	28 (17%)	27 (17%)
Elevated LDH ^g	39 (26%)	39 (26%)

Nb: Percentages based on evaluable patients. CLL= chronic lymphocytic leukemia; CVP=cyclophosphamide, vincristine, and prednisone; FL=follicular lymphoma; IWF= International Working Formulation; LDH=lactate dehydrogenase ^aPerformance status was defined according to the criteria of the Eastern Clinical Oncology Group. A higher score indicates poorer performance status; ^b Stage III-1: Involvement of lymph nodes on both sides of diaphragm. Abdominal disease limited to the upper abdomen (i.e., spleen, splenic hilar nodes, celiac nodes, porta hepatica node); ^c Stage III-2: Involvement of lymph nodes on both sides of diaphragm. Abdominal disease including para-aortic, mesenteric, and iliac involvement with or without disease in the upper abdomen; ^dHigher scores indicate a greater risk of death; ^e symptoms were defined as fever, weight loss, and night sweats; ^f Bulky disease is defined as nodal or extranodal mass >7 cm at its greater diameter; ^g The percentage calculation was not based on the 159 and 162 patients in the CVP and R-CVP groups, respectively, because LDH normal values were unavailable for seven patients in the CVP group and 10 patients in the R-CVP group.

Baseline characteristics used to determine patients in need of treatment in M39021 trial ^{95,94}

Parameter	R-CVP, no. (%) (N=162)^a	CVP, no. (%) (n=159)^a
Method of selecting patients		
BNLI criteria	45 (27.8)	46 (28.9)
Not BNLI criteria	117 (72.2)	113 (71.1)
B-symptoms ^b		
At least one present	65 (40.1)	51 (32.1)
All absent	97 (59.9)	108 (67.9)
Bulky disease ^c		
Yes	63 (38.9)	73 (45.9)
No	99 (61.1)	86 (54.1)
> 3 nodal sites with diameters > than 3 cm		
Yes	44 (27.2)	32 (20.1)
No	118 (72.8)	127 (79.9)
Baseline haemoglobin (R-CVP= 161, CVP= 158)		
Less than 100 g/L (%)	7 (4.3)	7 (4.4)
100 g/L or greater (%)	154 (95.7)	151 (95.6)
Baseline WBC (R-CVP= 161, CVP =158)		
Less than 3.0 10 ⁹ /L	1 (0.6)	1 (0.6)

Parameter	R-CVP, no. (%) (N=162)^a	CVP, no. (%) (n=159)^a
3.0 109/L or greater	160 (99.4)	157 (99.4)
Baseline neutrophils (R-CVP= 160, CVP =155)		
Less than 1.5 109/L	1 (0.6)	3 (1.9)
1.5 109/L or greater	159 (99.4)	152 (98.1)
Baseline platelets (R-CVP= 161, CVP =158)		
Less than 100 109/L	5 (3.1)	6 (3.8)
100 109/L or greater	156 (96.9)	152 (96.2)
Baseline β2 microglobulin (R-CVP= 147, CVP =141)		
Less than 3 mg/dL	1 (0.7)	0
3 mg/dL or greater	146 (99.3)	141 (100)
Baseline LDH (R-CVP= 152, CVP =152)		
Less than 2 ULN	39 (25.7)	39 (25.7)
2 ULN or greater	113 (74.3)	113 (74.3)
Baseline performance status ECOG (R-CVP= 162, CVP =158)		
Less than 1	4 (2.5)	8 (5.1)
1 or greater	158 (97.5)	150 (94.9)
Macroscopic liver involvement (R-CVP= 162, CVP =159)		
Yes	10 (6.2)	9 (5.7)

Parameter	R-CVP, no. (%) (N=162) ^a	CVP, no. (%) (n=159) ^a
No	152 (93.8)	150 (94.3)
Macroscopic renal involvement (R-CVP= 162, CVP =159)		
Yes	4 (2.5)	2 (1.3)
No	158 (97.5)	157 (98.7)
At least one symptom	132 (81.5)	125 (78.6)

BNLI= British Lymphoma Investigation Group; LDH=lactate dehydrogenase; ULN-upper limit of normal; WBC= white blood cells

^a Number per group unless otherwise stated ;^b symptoms were defined as fever, weight loss, and night sweats; ^c Bulky disease is defined as nodal or extranodal mass >7 cm at its greater diameter

Outcomes in the M39021 trial^{95,94}

	M39021^{94,95} Median FU=53 months	
Parameter	R-CVP N=162	CVP N=159
Overall response: Number (%)	131 (81) 95% CI (74% to 87%)	90 (57) 95% CI (49% to 64%)
p value	<0.0001	
Complete response (includes CRu): Number (%)	66 (41) 95% CI (33% to 49%)	16 (10) 95% CI (6% to 16%)
p value	<0.0001	
Partial response: Number (%)	65 (40)	74 (47)
	No p value reported	

	M39021^{94,95} Median FU=53 months	
Stable disease	12 (7)	33 (21)
p value	No p value reported	
Progressive disease	17 (11)	31 (20)
p value	No p value reported	
Overall survival rate (% alive using Kaplan-Meier estimate at 4 years)	83 95% CI (77 to 89)	77 95% CI (70 to 83)
p value	<0.0290	
Median overall survival	Not reached	Not reached
Number of deaths (42 month follow-up) (%)¹⁰¹	23 (14) ^a	35 (22) ^a
p value	No p value reported	
Deaths due to lymphoma: Number (%)	13 (8)	22 (14)
Median Time to treatment failure	27 months 95% CI (25 to 37)	7 months 95% CI (6 to 9)
p-value	<0.0001	
Median Response Duration	38 months 95% CI (28 to NE)	14 months 95% CI (9 to 18)
p-value	<0.0001	
Median Time To Next Treatment, months	49 (32 to NE)	12 (10 to 18)
p-value	<0.0001	
Median Disease-free survival, months	Not reached (35 to NE)	21 (14 to 38)
p-value	=0.0001	

	M39021^{94,95} Median FU=53 months	
Median Time to Progression, months	34 (27 to 48)	15 (12-18)
p-value	<0.0001	

Adverse events and treatment exposure reported in the M39021 trial^{95,94}

Adverse events (grade 3/4)	M39021^{95,94}	
	R-CVP N=162	CVP N=159
Neutropenia	39 (24)	22 (14)
Leukopenia taken from manufacturer's submission (could not be confirmed in manuscripts)	19 (12)	14 (9)
Experiencing at least one adverse event	157 (97)	153 (96)
Experiencing an adverse event with 24 hrs of infusion	115 (71)	81 (51)
Experiencing a total of 6 life threatening adverse event	5(3)	0
Grade 3 or 4 rituximab infusion related reaction	14 (9)	Not applicable
Leaving study before completing 4 cycles	6 (4)	13 (8%)
Leaving study early before completing 8 cycles	25 (15)	51 (32)

Treatment-related deaths	0 (0)	0 (0)
--------------------------	-------	-------

Number of treatment cycles and dose administered in M39021 trial^{95,94}

R-CVP N=162	CVP N=159
8 cycles administered to n=144 (89%)	8 cycles administered to n=103 (6%5)
<p>90% patients received the planned dose of prednisolone and vincristine at each administered cycle and this was comparable between the R-CVP and CVP arms. The proportion of patients who received more than 90% of cyclophosphamide was higher in the CVP group (>94%) than the R-CVP group (>85%). Ninety-six percent of patients received more than 90% of the planned dose of rituximab at each administered cycle.</p>	

Subgroup analyses

Multivariate analysis assessed the prognostic value of various parameters (BNLI criteria, age, extranodal sites, LDH, FLIPI, IPI, bone marrow involvement, elevated 2- microglobulin, B symptoms, bulky disease, nodal areas, haemoglobin level) on outcome in terms of TTP in the presence of the trial treatment effect. Only the FLIPI (categorized as 0 to 2 v 3 to 5 in the analysis) was a significant prognostic parameter for TTP in addition to the trial treatment. Patients with a FLIPI score of 0 to 2 who received R-CVP had the longest TTP. No other prognostic factor improved the predictive power. In two further multivariate analyses (one utilizing IPI instead of FLIPI, the other considering neither of the composite factors FLIPI and IPI), only haemoglobin level and number of nodal areas were found to be statistically significant predictors of TTP in addition to trial treatment.

Subgroup analyses of efficacy data in M39021 trial^{95,94}

Prognostic Factor	R-CVP, N=162			CVP, N=159			
	Number	Median TTP (months)	95% CI	Number	Median TTP (months)	95% CI	P value
FLIPI score							
0-1	28	Not reached	38 to NE ^a	23	22	16 to 40	0.0085
2	62	37	28 to NE	56	17	13 to 25	0.0003
3 to 5	61	26	16 to 34	71	11	10 to 15	0.0004
IPI score							
0 to 1	73	44	30 to NE	70	20	13 to 26	<0.0001
2	57	27	20 to 39	57	14	10 to 17	0.0003
3 to 4	21	40	11 to NE	24	12	8 to 25	0.0333
Histology at central review (IWF)							
Class B	38	34	27 to NE	46	17	11 to 24	0.0037
Class C	82	35	26 to NE	69	15	10 to 21	<0.0001
Class D	19	Not reached	30 to NE	19	14	7 to 24	<0.0046
B symptoms							
≥1	65	32	22 to NE	51	17	12 to 23	0.0014
All absent	97	37	26 to 48	108	14	11 to 20	<0.0001
Bulky disease							
Yes	63	38	25 to 48	73	13	11 to 21	<0.0001
No	99	32	26 to NE	86	16	13 to 21	<0.0001
Haemoglobin, g/dL							
≥12	132	39	31 to NE	121	17	13 to 22	<0.0001
<12	29	11	9 to 28	35	12	10 to 16	0.3941

^aNot estimable

Median Time to treatment progression (months) according to baseline FLIPI scores (univariate analysis)

FLIPI	R-CVP N=162	CVP N=159
FLIPI 0-1 (good prognosis)	Not reached	22
FLIPI 2 (intermediate prognosis)	37	17
FLIPI 3-5 (poor prognosis)	26	11

GLSG-2000 trial^{90,91}

METHODS

Allocation: Randomised (computer generated, in blocks stratified)

Blinding: Open label

Setting: Germany, multicentre

Treatment duration: 6-8 cycles (up to 24 weeks)

Follow up: Median 58 months

Design: Parallel group, Intention-to-treat analysis

Power calculation: Yes

PARTICIPANTS

Diagnosis: Follicular lymphoma (advance stage III-IV), untreated, grades I & II (WHO) classification

N=630 enrolled [not reported how many randomised]

Age: median age 57 (range 21-90)

Gender: 266 males and 291females

Inclusion criteria: Patients 18 years of age and older previously untreated, advanced-stage FL grades 1 and 2 according to the World Health Organization (WHO) classification. stage III or IV disease and a requirement for therapeutic intervention as defined by the presence of B-symptoms (night sweats, fever, or weight loss), bulky disease (mediastinal lymphomas greater than 7.5 cm or other lymphomas greater than 5 cm in maximal diameter), impairment of normal hematopoiesis with hemoglobin level less than 100 g/L, granulocyte count less than 1.5 10⁹/L, thrombocyte count less than 100 10⁹/L, or rapidly progressive disease.

Exclusion criteria: Patients were ineligible if they had FL grade III, were pregnant or lactating, or were women of childbearing potential not using a reliable method of contraception.

INTERVENTIONS

1. CHOP. Dose: 750 mg/m² cyclophosphamide; 50 mg/m² doxorubicin , 1.4 mg/m² vincristine: all given IV on day 1. Prednisolone given 100mg/m² daily on days 1 to 5 orally. N=278.
2. Rituximab + CHOP. Dose rituximab: 375 mg/m² the day before the respective R-CHOP course. N=279.

Treatment cycles were repeated after every 3 weeks for a total of 6 to 8 cycles.

Patients achieving CR after 4 cycles were treated with a total of 6 cycles only, whereas all other patients received 8 courses of CHOP or R-CHOP.

Treatment cycles: Every three weeks for a total of 6 to 8 cycles; number of cycles, patients achieving CR after 4 cycles were treated with a total of 6 cycles; all other patients received 8 cycles. Patients with progressive disease at anytime during R-CHOP or CHOP therapy were withdrawn from treatment.

MAINTENANCE THERAPY

Patients younger than 60 years achieving complete or partial response after CHOP or R-CHOP were offered a second randomisation for treatment in remission to either intensification by the DEXA-BEAM regimen consisting of dexamethasone 3 x 8 mg/day orally on days 1 to 10, bischloroethylnitrosourea (BCNU) 60 mg/m² daily on day 2, melphalan 20 mg/m² daily intravenously on day 3, etoposide 75 mg/m² daily intravenously on days 4 to 7, and cytosine arabinoside 2 x 100 mg/m² every 12 hours intravenously on days 4 to 7 with subsequent stem cell harvest followed by myeloablative radiochemotherapy with total body irradiation (12 Gy) and cyclophosphamide 60 mg/kg daily for 2 days and stem cell retransfusion or long-term interferon- (IFN- α) maintenance initiated at a dose of 3 x 5 million units/wk and reduced according to observed adverse effects. IFN maintenance therapy was given until lymphoma progression or the development of intolerable adverse effects. Second randomisation stratified for type of initial therapy (R-CHOP or CHOP) and the response (CR or PR). Only 25 patients did not receive either of these options.

Enrolment details and diagnosis

630 enrolled from 200 institutions between May 2000 and August 2003. In June 2003, significantly longer TTF recorded for R-CHOP arm ($p=0.001$) and randomisation stopped according to the protocol in August 2003. Grade 1 or 2 histological diagnosis for 390 patients confirmed by a central pathology review, 38 patients results still pending.

Evaluation response and definitions

Tumour response and progression was determined using the guidelines by Cheson et al. Response to therapy assessed every 2 cycles and 4 weeks after completion of last course, and consisted of:

- Physical exam- every three months
- Blood count and lactate dehydrogenase (LDH) level- every three months
- US of abdomen-every three months
- CT scan of previously involved areas every 6 months
- Patients fulfilling CR criteria had BM biopsy- every three months

Time to treatment failure was defined as the interval between the start of treatment and the documentation of resistance to initial therapy, disease progression or death. Response duration was defined as the interval from the end of successful induction therapy to the documentation of disease progression or death. Overall survival was defined as the interval between start of treatment and death. Time to next antilymphoma treatment was not defined.

Baseline characteristics

Baseline characteristics in GLSG-2000 trial⁹¹

Characteristic	R-CHOP n=279		CHOP N=278		P value
Median age (yrs), min-max	57	27-90	57	21-81	0.79
Male	120	43%	146	53%	0.027
Ann Arbor stage IV	194	70%	191	69%	0.85
Bone marrow involved	180	65%	179	64%	1.00
B-symptoms	108	39%	113	41%	0.60
Elevated LDH	73	26%	66	24%	0.56
Hb < 120 g/L	54	20%	56	20%	0.83
ECOG Performance Status 0	97	36%	88	32%	0.82
ECOG Performance Status 1	155	57%	167	61%	Not reported
ECOG Performance Status > 2	18	7%	19	7%	Not reported
FLIPI low risk	39	14%	31	11%	0.61
FLIPI intermediate risk	114	41%	119	44%	Not reported
FLIPI high risk	123	45%	123	45%	Not reported

Outcomes in the GLSG-2000 trial^{91,90}

	GLSG-2000 trial^{91,90} (median follow-up=56 months)	
	R-CHOP N= 279	CHOP N= 278
OR: Number (%)	271 (97) No CI reported	253 (91) No CI reported
p value reported in study	=0.0046	
Complete response: Number (%)	53 (20)	47 (17)
p value reported in study	No p value reported	
Partial response (includes unconfirmed complete responses): Number (%)	215 (77)	187 (74)
	No p value reported	
Stable disease including minor response	6 (2)	17 (6)
p value reported in study	No p value reported	
Progressive disease	3 (1)	6 (2)
p-value reported in study	No p value reported	
OS 5-year rate %	90 (CI NR)	84 (CI NR)
p-value reported in study	=0.0493	
Median OS	Not reached	Not reached
Number of deaths reported at 3 years⁹¹	6	17
p-value reported in study	=0.016	
Median Time to treatment failure	Not reached	35 months
p-value	<0.0001	
Duration of response at 5 years	66%	35%

p-value reported in study	p<0.0001	
Median Time to next anti-lymphoma treatment (reported at 18-month follow-up)⁹¹	Not reported	Not reported
p-value reported in study	=0.001	

ADVERSE EVENTS

Deaths reported in GLSG-200 trial⁹¹

GLSG-200 trial ⁹¹		
	R-CHOP N=223	CHOP N=205
Death due to lymphoma	1 (0)	9 (4)
Death due to infection	4 (2)	4 (2)
Death due to Cardiac failure	0	1 (0)
Apoplectic insult	0	1 (0)
Death due to GVHD after ASCT	0	1 (0)
Death cause unknown	1 (0)	1 (0)
Death by 18 months	2 (1)	2 (1)
Death by 36 months	6 (3)	17 (8)
	(p=0.016)	

Adverse events reported in GLSG-2000 trial⁹¹

GLSG-2000 trial ⁹¹						
	R-CHOP N=223	CHOP N=205	R-CHOP N=223	CHOP N=205	R-CHOP N=223	CHOP N=205
	Grade 1 and 2		Grade 3		Grade 4	
Haemoglobin level	112 (50)	100 (49)	18 (8)	18 (9)	2 (1)	2 (1)
Leukocyte	54 (24)	57 (28)	96 (43)	78 (38)	58 (26)	47 (23)
Granulocyte	42 (19)	41 (20)	49 (22)	47 (23)	91 (41)	62 (30)
Platelets count	38 (17)	33 (16)	9(4)	10 (5)	4 (2)	6 (3)
Infection	74 (33)	59 (29)	11 (5)	12(6)	0 (0)	2 (1)
Bleeding	9 (4)	6 (3)	0 (0)	0 (0)	0 (0)	0(0)
Nausea/vomiting	100 (45)	90 (44)	9 (4)	12(6)	0 (0)	0(0)
Stomatitis	58 (26)	59 (29)	2 (1)	4 (2)	0 (0)	0(0)
Obstipation	33 (15)	27 (13)	4 (2)	2 (1)	0 (0)	0 (0)
Diarrhoea	25(11)	23(11)	4 (2)	6 (3)	0 (0)	0 (0)
Fever	65 (29)	45 (22)	0 (0)	2 (1)	0 (0)	0 (0)
Cardiac dysfunction	7 (3)	8 (4)	4 (2)	2 (1)	2 (1)	0 (0)
Alopecia	42 (19)	51 (25)	140 (63)	115 (56)	9 (4)	10 (5)
Cardiac arrhythmia	13 (6)	8 (4)	2 (1)	0 (0)	2 (1)	0 (0)
Neurotoxicity	76 (34)	86 (42)	2 (1)	4 (2)	0 (0)	0 (0)
CNS toxicity	4 (2)	4 (2)	2 (1)	0 (0)	0 (0)	0 (0)

Allergy	13 (6)	0 (0)	2 (1)	0 (0)	0 (0)	0 (0)
	R-CHOP N=223			CHOP N=205		
Infections including fevers of unknown origin	11 (5)			14 (7)		
Stopped treatment due to adverse events	2 (1)			0 (0)		
Early cessation of rituximab AEs (%)	2 (1)			0 (0)		

Number of treatment cycles and dose administered: not reported

Subgroup analyses in GSLG-2000 trial⁹¹ time to treatment failure (TTF) and overall survival

Subgroup		Result
Age	<60	Median TTF not reached for CHOP (P for Cox regression=0.003) Estimated Relative risk for TTF for R-CHOP: 0.417 ,95% CI (0.233 to 0.747)
	≥60 or older	Median TTF 29 months for CHOP (p for Cox regression=0.004). Estimated Relative risk for TTF for R-CHOP: 0.354 , 95% CI (0.175-0.715)
IPI score	1-2	Median not reached (p for Cox regression=0.001) Estimated Relative risk for TTF for R-CHOP 0.412, 95% CI (0.242 to 0.701)
	3-5	29 months (P for Cox regression=0.009) Estimated Relative risk for TTF for R-CHOP 0.33, 95% CI (0.144-0.761)
Elderly patients		Estimated 4-years progression free survival was 62.2% for R-CHOP (n=109) versus 27.9 % after CHOP (n=112) (log rank: p< 0.0001). R-CHOP (n=109) prolonged overall survival in elderly patients with an estimated 4-years overall survival of 90% after immunochemotherapy versus 81 % after CHOP (n=112) alone (log rank test: p=0.039).
FLIPI score	Low risk group	R-CHOP prolonged 5-years TTF: R-CHOP 84% vs. 46% CHOP (p=0.0021)
	Intermediate risk group	TTF prolonged 5-years R-CHOP 73% vs. 37% CHOP (p<0.0001)
	High risk group	TTF prolonged 5-years R-CHOP 49% vs. CHOP 23% (p<0.0001)

OSHO-39 trial (Herold et al)⁹²

METHODS

Allocation: randomised (random number list)

Blinding: Open label

Setting: Germany, 34 centres

Treatment duration: 32 weeks consisting of 8 treatment cycles of rituximab

Follow up: Median 49 months for R-MCP, 42 months MCP (no range reported)

Design: parallel group, Intention-to-treat analysis

Power calculation: Yes (using primary population of follicular lymphoma)

PARTICIPANTS

Diagnosis: Follicular lymphoma

N=358 total (201 with FL)

Age: Median age MCP arm: 57 (range 31-75) Median age R-MCP arm 60 (33-78)

Gender: 89 males and 112 females

Inclusion criteria: age 18 and 75 years, untreated, histologically confirmed, CD20 indolent NHL (FL, grade 1 and 2 only; lymphoplasmacytic lymphoma) and MCL. Stage III or IV disease according to the Ann Arbor classification General performance status of less than or equal to 2 according to the Eastern Cooperative Oncology Group scale. Needing treatment for either, B symptoms or extranodal manifestation, hematopoietic insufficiency, rapid tumor growth, bulky disease (lymphoma > 7.5 cm in diameter; mediastinal tumor one third of thorax diameter at thoracic vertebra 5/6); or immunohematologic phenomena (eg, hemolytic anemia or immune thrombocytopenia)

Exclusion criteria:

Patients with concomitant diseases and/or restricted organ function not caused by lymphoma or patients with HIV infection were excluded from the study.

INTERVENTIONS

1. MCP. Dose mitoxantrone (8 mg/m² intravenously) on days 3 and 4, chlorambucil (3 3mg/m²orally)on days 3 to 7, and prednisolone (25 mg/m² orally) on days 3 to 7. N= 96
2. Rituximab-MCP. Dose rituximab 375 mg/m² intravenously on day 1 of each therapy cycle, followed by mitoxantrone (8 mg/m² intravenously) on days 3 and 4, chlorambucil (3 3mg/m²orally) on days 3 to 7, and prednisolone (25 mg/m² orally) on days 3 to 7. N=105.

MAINTENANCE

Maintenance therapy with interferon alfa-2a (4.5 MU three times per week until relapse) was planned in all study patients with FL who had achieved partial remission (PR) or complete remission (CR) and was initiated within 4 to 8 weeks after treatment completion; thus 3 x 4.5 MU per week until disease progression was initiated in 97% (n=102) and 92% (n=88) of planned patients in the R-MCP group and MCP group, respectively.

Enrolment details and diagnosis

Enrolment occurred between October 1998 and September 2003 at 34 centres in Germany. Follicular lymphoma was confirmed histologically by a designated reference pathologist.

Evaluation response and definitions

After completion of induction treatment, patients were observed every 8 weeks during the first year, at 3-month intervals during the second year, and then every 6 months from the third year onward. Tumour responses were assessed after two treatment cycles, after six treatment cycles, and 4 weeks after completion of study treatment. Response assessment included all diagnostic measures used in the pre-therapeutic staging (including computed tomography scans of neck, chest, abdomen, and pelvis and bone marrow biopsy).

Patients with disease progression after two cycles of therapy were prematurely withdrawn from study treatment and were considered as having treatment failure in the analysis of EFS. Patients who had not reached a PR or CR after six cycles of therapy were also classified as experiencing treatment failure in the EFS analysis. Patients with a CR or a PR after six cycles of chemotherapy or immunochemotherapy, respectively, received a further two consolidation cycles of MCP or R-MCP for a total of eight treatment cycles.

Progression free survival was defined as randomisation to disease progression or death from NHL. Overall survival was defined as the time from randomisation to the date of death by any cause. Response duration was defined as the time between response to treatment and disease progression or death by any cause. Event free survival was defined as the time between randomisation and relapse, disease progression or disease progression after two cycles or partial response after 6 cycles. Time to next antilymphoma treatment was defined as time between randomisation and date of next/new treatment.

Baseline characteristics

Baseline characteristics of OSHO-39 trial⁹²

Characteristic	R-MCP n=105 Number (%)	MCP n=96 Number (%)
Age, median (range)	57 (31-75)	60 (33-79)
Males	36 (37)	53 (50)
Ann Arbour Stage III	22 (23)	30 (29)
Ann Arbour Stage IV	74 (77)	75 (71)
ECOG performance status 0	54 (56)	69 (65)
ECOG performance status 1	36 (39)	29 (29)
ECOG performance status 2	6 (6)	7 (7)
LDH > normal	30 (31)	31 (30)
Bone marrow infiltrate	71 (74)	73 (70)
B symptoms: Nightly sweating	34 (35)	46 (44)
B symptoms: Fever >38°C	2 (2)	4 (4)
B symptoms: weight loss > 10% within 6 months	20 (21)	16 (15)
FLIPI Low (0-1)	6 (6)	9 (9)
FLIPI Intermediate (2)	37 (39)	39 (36)
FLIPI High (3-5)	53 (55)	59 (56)

Outcomes in OSHO-39 trial⁹²

	OSHO-39⁹² (median follow-up)	
	R-MCP N=105	MCP N=96
OR: Number (%)	97 (92) No CI reported	72 (75) No CI reported
p value reported in study	=0.0009	
CR: Number (%)	52 (50)	24 (25)
p value reported in study	=0.0004	
PR (includes unconfirmed complete responses): Number (%)	45(43) No p value reported	48 (50)
Stable disease	Not reported ^a	Not reported ^a
p value reported in study	No p value reported	
Progressive disease	3 (3) [After 2 cycles]	10 (10) [After 2 cycles]
p value reported in study	No p value reported	
OS rate at 4 years %	87 (CI NR)	74 (CI NR)
p value reported in study	=0.0096	
Median OS	Not reached	Not reached
Number of deaths at 4 years	15	25
p value reported in study	No p value reported	
Median PFS, months	Not reached	28.8

	OSHO-39⁹² (median follow-up)	
	R-MCP N=105	MCP N=96
p value reported in study	<0.0001	
Number of events	30 (29%)	50 (52%)
% PFS at 4 years	71%	40%
Median EFS, months	Not reached	26
p-value	<0.0001	
Median response duration, months	Not reached	35
p-value	<0.0001	
Median TTNT, months	Not reached	29.4
p-value	=0.0002	

^a Stable disease not reported but “< partial response” reported at cycle 6: R-MCP= 7 & MCP=22 and at cycle 8: R-MCP= 8 & MCP=24

Deaths reported in OSHO-39 trial⁹²

	R-MCP N=105	MCP N=96
Death cause unknown	15 (14)	25 (26) 0
Cause-specific deaths (p=0.0159)	7 (7)	17 (18)

Adverse events reported in OSHO-39 trial⁹²

Adverse events: N (%)	OSHO-39⁹²					
	Grade 1 or 2		Grade 3		Grade 4	
	R-MCP N=105	MCP N=96	R-MCP N=105	MCP N=96	R-MCP N=105	MCP N=96
Haemoglobin level	18 (17)	18 (19)	2 (2)	3 (3)	1 (1)	1 (1)
Leukocyte/WBC	3 (3)	8 (8)	25 (24)	21 (22)	50 (48)	35 (36)
Platelets count	31 (30)	32 (33)	4 (4)	6 (6)	0 (0)	1 (1)
Infection	44 (42)	34 (35)	6 (6)	7 (7)	1 (1)	1 (1)
Nausea/vomiting	25 (24)	14 (14)	1 (1)	6 (6)	0 (0)	0 (0)
Stomatitis	11 (10)	7 (7)	1 (1)	1 (1)	0 (0)	0 (0)
Diarrhoea	11 (10)	4 (4)	2 (2)	0 (0)	0 (0)	2 (2)
Rash	16 (15)	1 (1)	0 (0)	2 (2)	0 (0)	0 (0)

	OSHO-39⁹²					
	Grade 1 or 2		Grade 3		Grade 4	
Heartburn	15 (14)	3 (3)	1 (1)	0 (0)	0 (0)	0 (0)
Insomnia	15 (14)	7 (7)	0 (0)	0 (0)	0 (0)	0 (0)
Bone pain	10 (10)	10 (10)	2 (2)	0 (0)	0 (0)	0 (0)
Gastro-intestinal	9 (9)	5 (5)	2 (2)	1 (1)	0 (0)	1 (1)
Other (not specified)	11 (10)	8 (8)	0 (0)	1 (1)	0 (0)	1 (1)

Number of treatment cycles and dose administered in OSHO-39 trial

R-MCP N=105	MCP N=96
8 cycles administered to n=92 (88%)	8 cycles administered to n=64 (67%)
<p>The mean dose of study drugs administered in the OSHO-39 trial⁹² were rituximab, 660–680 mg/cycle; mitoxantrone, 24–28 mg/cycle; chlorambucil, 68–81 mg/cycle and prednisolone, 226–231 mg/cycle.</p> <p>The authors stated that the dose intensity of the chemotherapy did not differ between treatment arms.⁹²</p> <p>Interferon-α maintenance treatment (3 x 4.5 million units per week until disease progression) was initiated in 97% and 92% of responding patients in the R-MCP and MCP arms, respectively.</p>	

Subgroup analyses

None

FL2000 trial (Salles et al)⁹³

METHODS

Allocation: randomised (methods not specified)

Blinding: open label

Setting: France and Belgium, 54 centres

Treatment duration: 72 weeks

Follow up: median 5 years (range: 0.2-6.4 years)

Design: Parallel, Intention-to-treat analyses

Power calculation: Yes

PARTICIPANTS

Diagnosis: Follicular lymphoma

N=360 (*358 analysed) (1 patient withdrew consent after registration; 1 patient had a major inclusion violation (which was registered at relapse))

Age: median 61 years (range 25-75)

Gender: 178 males and 180 females

Inclusion criteria: Untreated patients 18-75 years of age ; histologic diagnosis of FL grade 1, 2, 3a performed in last 3 months on LN biopsy (pathologic review by panel of 3 expert pathologists) stage II-IV (Ann Arbor); fulfil any one of following criteria for high tumour burden: (1) presence of a bulk tumour defined by either one of the following: tumour lesion with a largest diameter greater or equal than 7 cm, spleen enlargement with a craniocaudal diameter greater than 20 cm, existence of 3 lymph nodes in 3 distinct nodal areas with a diameter greater or equal than 3 cm, pleural effusion, ascites, or symptomatic compressive syndrome; (2) presence of B symptoms (fever, night sweats, or weight loss); (3) a performance status on the Eastern Cooperative Oncology Group scale greater than 1;(4) elevated serum levels of lactic dehydrogenase (above normal values) or β 2-microglobulin (≥ 30 mg/dL).

Exclusion criteria: Patients with contraindications to anthracyclines, interferon, or rituximab, with known positivity for HIV or active viral hepatitis, or with a previous malignancy were not eligible for the study.

INTERVENTIONS

1. CHVPi: 12 courses: 6 courses every 28 days, 6 courses every 56 days c: 600 mg/m² cyclophosphamide intravenously on day 1, 25 mg/m² adriamycin/doxorubicin intravenously on day 1, 100 mg/m² etoposide: intravenously on day 1, 40 mg/m² prednisolone orally from day 1 to day 5. Interferon-alpha2a subcutaneously during 18 months, 3 times a week at an initial dose of 4.5 million units (MU) per injection for patients younger than 70 years or 3 MU per for patients older than 70 years. N=183.
2. Rituximab + CHVPi. Doses as per comparator arm on same days of cycle. Rituximab= 375 mg/m². 6 cycles every 28 days. however cycles 1 and 2: CHVPi only; cycles 3, 4: R-CHVP-I (+extra R on day 8 of cycle); cycles 5 + 6= RCHVP-I: Cycles 7-12- interferon only every 56 days. N=175.

MAINTENANCE THERAPY

None

Evaluation and response and outcomes definitions

- Evaluation of response performed after 6 chemotherapy courses (6 months) and at the end of the whole treatment (18 months).
- Disease evaluation for response assessments was recommended in the International Workshop criteria: Complete response (CR): disappearance of all lesions and of radiologic or biologic abnormalities observed at diagnosis and the absence of new lesions. Unconfirmed complete response (CRu): CR with persistence of some radiologic abnormalities, which had to have regressed in size by at least 75%. Partial response (PR): regression of all measurable lesions by more than 50%, the disappearance of nonmeasurable lesions, and the absence of new lesions. Stable disease: regression of any measurable lesion by 50% or less or no change in the nonmeasurable lesions, but without growth of existing lesions or the appearance of new lesions.
- Progressive disease: appearance of a new lesion, any growth of the initial lesion by more than 25%, or growth of any measurable lesion that had regressed during treatment by more than 50% from its smallest dimensions.
- Responding patients with previous bone marrow involvement for which bone marrow evaluation was missing at evaluation were considered as having a PR even if they met the criteria of CRu or CR. Any residual marrow infiltrate that could not be demonstrated to be a reactive infiltrate using immunostaining was considered as a positive bone marrow biopsy, and the response, if other criteria were met, as a PR.
- Patients who completed their treatment had a complete clinical examination every 3 months for the first year and then every 6 months for 5 years. A CT scan was performed yearly, and a new bone marrow biopsy was performed 18 months after treatment completion or when clinically indicated.
- Overall survival was defined as the time from randomisation to the date of death by any cause. Event free survival was defined as time from randomisation to disease progression, death any cause, relapse or new antilymphoma treatment. Response duration was defined as

Enrolment details and diagnosis

Patients were enrolled between May 2000 and May 2002. Histologic diagnosis of FL grade 1, 2, 3a performed in last 3 months on LN biopsy (pathologic review by panel of 3 expert pathologists for 344 patients, 4 diagnoses of FL could not be formally confirmed due to technical problems, 12 cases were classified as non FL subtypes), according to WHO criteria.

Baseline characteristics on FL2000 trial⁹³

Patient characteristics	R-CHVPi (n, %)	CHVP-I (n, %)	Missing values
ECOG performance status > 1	11 (6%)	16 (9%)	0 missing values
B symptoms presence	38 (22%)	52 (29%)	1 missing value
Ann Arbor stage III or IV	152 (87%)	165 (91%)	2 missing values
Number of nodal sites involved > 4	86 (49%)	78 (43%)	0 missing values
Bone marrow involvement:	108 (62%)	121 (67%)	4 missing values
Extranodal sites > 1	60 (35%)	73 (40%)	3 missing values
LDH more than upper normal value	64 (37%)	66 (36%)	5 missing values
Haemoglobin < 12 g/dL	37 (21%)	30 (17%)	2 missing values
β 2-microglobulin > 3 mg/L	62 (38%)	56 (33%)	28 missing values
IPI score > 2	60 (36%)	71 (39%)	10 missing values
FLIPI 0-1 factors	28 (16%)	37 (21%)	9 missing values
FLIPI 2 factors	63 (37)	59 (33)	9 missing values
FLIPI 3 factors or more	79 (46)	83 (46)	9 missing values

Outcomes in the FL2000 trial⁹³

	FL2000⁹³ (Median follow-up= 60 months)			
	6 month follow-up data		18 month follow-up data (response rate only)	
	R-CHVPi N= 175	CHVPi N=183	R-CHVPi N= 175	CHVPi N=183
OR: Number (%) (No CI reported)	164 (94%)	156 (85%)	142 (81)	131 (72)
p value reported in study	Not reported		Not reported	
CR: Number (%)	63(36)	29(16)	90 (51)	71 (39)
p value reported in study	<0.001 ^a		=0.035 ^a	
PR^d: Number (%)	101(58)	127 (69)	52 (30)	60 (33)
	<0.001 ^a		=0.035 ^a	
Stable disease	2 (1)	9 (5)	1 (1)	3 (2)
p value reported in study	<0.001 ^a		=0.035 ^a	
Progressive disease	8 (5)	18 (10)	31 (18)	47 (26)
p value reported in study	<0.001 ^a		=0.035 ^a	
Overall survival rate at 5 years%	84, 95% CI (78-84)	79, 95% CI (72-84)	^a P values calculated by Salles <i>et al.</i> ⁹³ using a global X ² test for all strata	
p value reported in study	=0.1552			
Median overall survival	Not reported			
Number of deaths at 18 months	1 (1)	2 (1)		
p value reported in study	No p value reported			
Median event-free survival (EFS), months	Not reached	35		
p value reported in study	=0.0004			
5 yr EFS	53% (95% CI, 45%-60%)	37% 95% CI (29%-44%)		
p value reported in study	= 0.001			
Duration of response at 4 years	64% ^b (95% CI, 55%-72%)	37% 95% CI (29%-44%)		
p value reported in study	=0.012			

Adverse events (grade 3 and 4 combined) in the FL200 trial⁹³

	Induction (6 months of treatment)		Consolidation additional (12 months of treatment)	
	R-CHVPi N=175	CHVPi N=183	R-CHVPi N=175	CHVPi N=183
Haemoglobin level	6 (3)	9 (5)	1 (1)	4 (2)
Neutrophil	103 (59)	114 (62)	11 (6) ^a	69 (38)
Platelet count	5(3)	6 (3)	2 (2)	4 (2)
Fever	2 (1)	2 (1)	0 (0)	1 (1)
Infection	4 (2)	0 (0)	2 (1)	2 (1)
Cardiac dysfunction	2 (1)	3 (2)	0 (0)	1 (1)

^a Significant difference between two treatment arms, p<0.001

Numbers of cycles administered

- 95% of patients in the R-CHVPi arm and 94% of patients in the CHVPi arm received the initial 6 cycles of treatment
- Amongst patients who did not progress during therapy, 161 (98%) and 153 (98%) of the patients received the planned chemotherapy courses during the first 6 months in the R-CHVPi and CHVPi arms, respectively.
- In the CHVPi arm, 116 (87%) of 134 patients without death or progression received the 6 planned cycles of chemotherapy consolidation.
- 237 (66%) patients followed the interferon treatment according to the protocol, with dose adaptation (45 patients) or short (less than 4 weeks) interruptions (55 patients), without significant differences in adaptation between the 2 study arms.
- Interferon treatment was stopped in 50 patients resulting from disease progression (R-CHVPi arm. 19 cases and CHVPi arm, 31 cases, respectively) and was interrupted either for more than 1 month (16 cases) or definitively (72 cases) resulting from toxicity. These major interruptions were observed in 41 patients in the RCHVPi arm and 47 patients in the CHVPi arm.

Subgroup analyses

Because the FL2000 trial was not stratified by the FLIPI, checked for effects of prognostic factors on outcome resulting from sampling fluctuation in the treatment groups using multivariate analysis of survival. The Cox regression model included FLIPI and treatment as explanatory variables. The interactions between risk factors and treatment were also included in the model

Results:

Significantly different outcomes for each group both for 5-year EFS and OS ($P < 0.001$ for each). When the low- and intermediate-risk groups were considered together and compared with the high-risk group, this index was also able to discriminate risk groups for patients in each treatment arm. When considering together the 187 patients who presented either a low or an intermediate FLIPI score, no significant difference in outcome was observed according to each treatment arm. However, the outcome of the 162 patients with the highest FLIPI score (3-5 adverse prognostic factors) was found to be significantly different both for 5-year EFS ($P = .001$) and OS ($P = .025$) between the CHVP+I- and R-CHVP+I-treated patients. 5-year OS probability for patients in the FL2000 in the different FLIPI prognostic subgroups (low, intermediate, and high) was found to be, respectively, 95%, 89%, and 70% as opposed to 91%, 78%, and 53%

Appendix 12: Outcomes definitions for time to event data

Note: does not include OS or PFS

Table 89: Definitions used in the trials for Response duration

From when response (complete or partial) achieved to:

	Death not specified	Relapse	Disease progression	Death any cause
M39021 ^{94,95}	✓	✓		
GLSG-2000 ^{90,91}			✓	✓
OSHO-39 ⁹²			✓	
FL2000 ⁹³		✓	✓	✓

^a It was unclear how relapsed was defined and how this differed from disease progression

Table 90: Definitions used in the trials for Time to treatment failure

	Resistance to initial therapy	Disease progression	Death any cause	Death not specified	Relapse after response	New antilymphoma treatment	Stable disease after cycle 4
M39021 ^{94,95} From randomisation:			✓		✓	✓	✓
GLSG-2000 ^{90,91} From start of treatment	✓	✓		✓			

Table 91: Definitions used in the trials for Time to next antilymphoma treatment

From randomisation to

	Date of next/new treatment	Death not specified
M39021 ^{94,95}	✓	✓
GLSG2000 ^{90,91}	Not defined	
OSHO-39 ⁹²	✓	

Table 92: Definitions used in the trials for Event free survival

From randomisation to...

	Disease progression after 2 cycles or partial response at 6 cycles	Disease progression	Death any cause	Relapse	New antilymphoma treatment
FL2000 ⁹³		✓	✓	✓	✓
OSHO-39 ^{92 a}	✓	✓		✓	

^a All counted as a 'treatment failure' by Herold *et al.*⁹²

Table 93: Definitions used in the trials for other outcomes reported

Outcome	Study	Definition
Time to progression (TTP)	M39021 ^{94,95}	Randomisation to disease progression, relapse after response, death by any cause
Disease-free survival	M39021 ^{94,95}	Complete response to relapse or death (not specified)

Appendix 13: Chi square test analysis for response rate data

CR= complete response; CRu= unconfirmed complete response; PR=partial response;
SD= stable disease; PD= disease progression

Table 94: R-CVP vs. CVP Chi square test

	Observed		Expected	
	R-CVP	CVP	R-CVP	CVP
CR	49	12	30.8	30.2
PR (includes CRu)	82	78	80.7	79.3
SD	12	33	22.7	22.3
PD	17	31	24.2	23.8
Death	2	5	3.5	3.5
Treatment arm totals	162	159	162.0	159.0
p value	<0.001			

Table 95: R-CVP vs. CVP (combining PD and death categories) Chi square test

	Observed		Expected	
	R-CVP	CVP	R-CVP	CVP
CR	49	12	30.8	30.2
PR (includes CRu)	82	78	80.7	79.3
SD	12	33	22.7	22.3
PD + Dead	19	36	27.8	27.2
Treatment arm totals	162	159	162.0	159.0
p value	<0.001			

Table 96: R-CHOP vs. CHOP Chi square test

	Observed		Expected	
	R-CHOP	CHOP	R-CHOP	CHOP
CR	53	47	50.1	49.9
PR (includes CRu)	215	206	210.9	210.1
SD (includes 'minor response' as well)	6	17	11.5	11.5
PD	3	6	4.5	4.5
Dead	2	2	2.0	2.0
Treatment arm totals	279	278	279	278
p value	0.15			

Table 97: R-CHOP vs. CHOP (combining PD and death) Chi square test

	Observed		Expected	
	R-CHOP	CHOP	R-CHOP	CHOP
CR	53	47	50.1	49.9
PR (includes CRu)	215	206	210.9	210.1
SD (includes 'minor response' as well)	6	17	11.5	11.5
PD + Dead	5	8	6.5	6.5
Treatment arm totals	279	278	279.0	278.0
p value	0.09			

Table 98: R-MCP vs. MCP Chi square test

	Observed		Expected	
	R-MCP	MCP	R-MCP	MCP
CR	52	24	39.7	36.3
PR	45	48	48.6	44.4
<PR + PD	8	24	16.7	15.3
Treatment arm totals	105	96	105	96
p value	<0.001			

Table 99: R-CHVPi vs. CHVPi (6 months data) Chi square test

	Observed		Expected	
	R-CHVPi	CHVPi	R-CHVPi	CHVPi
CR	63	29	45.0	47.0
PR (includes CRu)	101	127	111.5	116.5
SD	2	9	5.4	5.6
PD	8	18	12.7	13.3
Dead	1	0	0.5	0.5
Treatment arm totals	175	183	175.0	183.0
p value	<0.001			

Table 100: R-CHVPi vs. CHVPi (6 months data): combining categories SD + PD + death Chi square test

	Observed		Expected	
	R-CHVPi	CHVPi	R-CHVPi	CHVPi
CR	63	29	45.0	47.0
PR (includes CRu)	101	127	111.5	116.5
SD + PD + Dead	11	27	18.6	19.4
Treatment arm totals	175	183	175.0	183.0
p value	<0.001			

Table 101: R-CHVPi vs. CHVPi (18 months data) Chi square test

	Observed		Expected	
	R-CHVPi	CHVPi	R-CHVPi	CHVPi
CR	90	71	78.70112	82.29888268
PR (includes CRu)	52	60	54.7486	57.25139665
SD	1	3	1.955307	2.044692737
PD	31	47	38.12849	39.87150838
Dead	1	2	1.46648	1.533519553
Treatment arm totals	175	183	175	183
p value	0.123063805			

Table 102: R-CHVPi vs. CHVPi- 18 months data: combining categories SD + PD + death

	Observed		Expected	
	R-CHVPi	CHVPi	R-CHVPi	CHVPi
CR	90	71	78.70112	82.29888268
PR (includes CRu)	52	60	54.7486	57.25139665
SD + PD + Dead	33	52	41.55028	43.44972067
Treatment arm totals	175	183	175	183
p value	0.031978375			

Appendix 14: Exploratory meta-analyses

Three exploratory meta-analyses were conducted to explore the results of synthesising the ORR, CR and PR from the four trials.

There were several problems with the validity of these analyses. Firstly, the level of statistical heterogeneity calculated in RevMan⁸⁹ using the I^2 statistic was very high (range $I^2=56-88\%$). The I^2 describes the percentage of the variability in effect estimates that is due to heterogeneity rather than sampling error (chance),¹⁰⁶ and an $I^2 >50\%$ is considered to be a high enough level of heterogeneity to suggest meta-analysis is not appropriate. Ideally, this high level of heterogeneity would be explored further and explained by estimating the predictive distribution of a new study. This was not undertaken due to resource constraints.

Reasons for the high level of heterogeneity could be due to differences in treatment effects in the four trials. Examination of the confidence intervals for the results from the individual trials showed that there was little overlap in the meta-analyses for CR, and to a lesser extent for PR, indicating evidence for heterogeneity of intervention effects. Indeed, the GLSG-2000^{91,90} trial observed much higher ORR (a combination of CR and PR) for both the R-chemotherapy and chemotherapy alone arms in comparison to the other studies. This was mostly accounted for by an increase in the numbers of PR (20% CR and 77% PR in the R-CHOP arm), whereas in the OSHO-39 trial⁹² there was a more even split between the CR/PR categories (R-MCP CR=50% and PR=43%). As well as evidence for different intervention effects in the four trials, there are other possible explanations for the high level of heterogeneity. Firstly, each study administered a different therapeutic intervention with respect to the chemotherapy regimen used; this included different chemotherapeutic agents (CVP, CHOP, MCP and CHVPi) and different regimens of treatment (three weekly versus four weekly cycles, 6 cycles of treatment versus 8 cycles of treatment). Secondly, there was a difference in the sample sizes of the studies; for example the GLSG-2000 trial^{90,91} was the largest trial with an intention-to-treat population of n=557 patients whilst the OSHO-39 trial⁹² was substantially smaller (n=201).

The AG also notes that the choice of chemotherapeutic regimen is not solely determined by clinical efficacy. For example, R-CHOP is less likely to be given to patients who are

elderly or unfit, whilst more likely to be given to treat aggressive or bulky disease, which may impact on the perceived efficacy. Additionally, the analyses assume that rituximab has no synergistic interaction with the chemotherapeutic component of a regimen for the treatment effect. The AG also comment that the analyses of ORR, CR and PR are not independent analyses given the same patients are counted in more than one analysis.

The AG therefore believes the response rates from the individual trials to be a more robust estimator of the efficacy of the specific R-chemotherapy regimens. These are subsequently used in the decision model (see section 6) rather than meta-analysed response rates. The findings from the meta-analyses are presented in below for completeness, but the use of these are strongly cautioned against.

Overall response rate

The addition of rituximab to chemotherapy showed a significant improvement in ORR compared with chemotherapy alone when the four trials were combined; with a relative risk of 1.18 (95% CI, 1.04-1.33, $p=0.01$). (Figure 51) This translated as an 18% increased likelihood of being a responder (complete or partial) to treatment if receiving R-chemotherapy compared with chemotherapy alone.

Figure 51: Forest plot for meta-analysis of overall response rate of the four trial



Complete response rate

The addition of rituximab to chemotherapy showed a significant improvement in CR compared with chemotherapy alone when the four trials were combined; with a relative risk of 2.05 (95% CI, 1.27-3.30, $p=0.003$). (Figure 52) This translated as a 105% (i.e. over double) increased likelihood of being a complete responder to treatment if receiving R-chemotherapy compared with chemotherapy alone.

Figure 52: Forest plot for meta-analysis of complete response rate of four trials



Partial response rate

The meta-analysis of PR incorporated the results from three trials (M39021 trial^{94,95} not being directly comparable- see section 5.2.2 for further details). For PR, the addition of rituximab to chemotherapy did not show a significant improvement in PR compared with chemotherapy; the relative risk calculated as 0.95 (95% CI, 0.83-1.08, $p=0.44$); this translated as a 5% decreased likelihood of being a partial responder if receiving R-chemotherapy compared to chemotherapy alone (Figure 53).

Figure 53: Forest plot for meta-analysis of partial response rate of four trials



The meta-analysed PR appears counter-intuitive when compared with the meta-analysed results for ORR and CR. However, this might be explained by the way in which the rituximab-chemotherapy combination affects the movement of the number of patients within each response category ('non-responder', 'partial responder' and 'complete responder'). It is plausible that the rituximab-chemotherapy combination might 'shift' more non-responders to partial responders relative to the chemotherapy alone group, thus increasing the numbers within the PR group. However, at the same time the rituximab-chemotherapy combination appears to have an effect in patients who would otherwise be partial responders and 'shift' such patients to 'complete responders'. This effect of shifting PRs to CRs would thus reduce the numbers within the PR group, negating the increase in numbers with the PR group as a result of the 'non-responder' to 'PR' conversion. These two effects may result in the number of PRs in the R-chemotherapy arm being similar to the number of PRs in the chemotherapy alone group.

Using the FL2000 18-month response rate data

The six-month response rate data from the FL2000 trial⁹³ were considered most appropriate for the meta-analysis of response rates as the intervention and comparator treatment arms up until that timepoint was comparable with the other three trials. The trial participants went on to receive a further 12 months of treatment which consisted of interferon only for the both treatment arms and bimonthly CHVP for the comparator arm. The results are presented in Figures 54 to 56. The use of the 18-month response

rate data did not materially affect the results, with the exception of reducing the median relative risk by 0.4 for CR and reducing statistically heterogeneity considerably in the analysis of PR.

Figure 54: Forest plot for meta-analysis of overall response rate using the FL2000⁹³ 18-month response rates



Figure 55: Forest plot for meta-analysis of complete response rate using the FL2000⁹³ 18-month response rates



Figure 56: Forest plot for meta-analysis of partial response using the FL2000⁹³ 18-month response rates



Appendix 15: Full results of sensitivity analyses

Table 103: Sensitivity analyses for R-CVP versus CVP

	CVP			R-CVP (base case)			R-CVP (scenario)			ICER – Cost per QALY gained	
	LY	QALY	Cost	LY	QALY	Cost	LY	QALY	Cost	Base case	Scenario
Base case	9.86	5.99	£30,793	11.50	6.95	£38,183	12.03	7.25	£49,520	£7,720	£14,959
Time horizon											
5 years	4.06	2.98	£23,278	4.37	3.22	£28,360	4.43	3.27	£38,683	£20,998	£54,094
10 years	6.57	4.51	£27,472	7.38	5.07	£33,813	7.60	5.22	£44,673	£11,287	£24,126
Lifetime	10.80	6.24	£31,278	12.69	7.26	£38,795	13.30	7.57	£50,186	£7,360	£14,125
Discounting											
0% costs, 0% benefits	9.86	7.73	£35,632	11.50	9.09	£44,002	12.03	9.52	£56,241	£6,147	£11,469
0% costs, 3.5% benefits	9.86	5.99	£35,632	11.50	6.95	£44,002	12.03	7.25	£56,241	£8,745	£16,463
3.5% costs, 0% benefits	9.86	7.73	£30,793	11.50	9.09	£38,183	12.03	9.52	£49,520	£5,426	£10,421
Parametric distribution											
Weibull	9.76	5.94	£31,041	11.37	6.89	£38,669	11.81	7.15	£50,199	£8,054	£15,958
Gompertz	9.97	6.05	£30,279	12.18	7.26	£35,349	12.91	7.66	£45,421	£4,174	£9,419
Death event in PFS											
none	10.30	6.25	£32,058	11.72	7.07	£38,766	12.22	7.35	£50,046	£8,224	£16,386
CVP arm	9.86	5.99	£30,793	11.35	6.87	£37,759	11.89	7.17	£49,139	£7,984	£15,599
R-CVP arm	10.04	6.10	£31,327	11.50	6.95	£38,183	12.03	7.25	£49,520	£8,080	£15,914
Resistance to rituximab											
-10%	9.86	5.99	£30,793	11.19	6.79	£38,229	11.76	7.11	£49,565	£9,379	£16,851
-15%	9.86	5.99	£30,793	11.01	6.70	£38,246	11.61	7.03	£49,579	£10,616	£18,100

	CVP			R-CVP (base case)			R-CVP (scenario)			ICER – Cost per QALY gained	
	LY	QALY	Cost	LY	QALY	Cost	LY	QALY	Cost	Base case	Scenario
-20%	9.86	5.99	£30,793	10.82	6.60	£38,249	11.45	6.95	£49,586	£12,328	£19,650
-25%	9.86	5.99	£30,793	10.62	6.50	£38,235	11.28	6.86	£49,580	£14,870	£21,624
-30%	9.86	5.99	£30,793	10.41	6.38	£38,210	11.09	6.77	£49,563	£19,102	£24,234
Utility values											
PFS1 = 0.805; PFS2 = 0.805; PD = 0.7363	9.86	5.81	£30,793	11.50	7.01	£38,183	12.03	7.39	£49,520	£6,180	£11,862
PFS1 = 0.805; PFS2 = 0.805; PD = 0.7363	9.86	6.08	£30,793	11.50	7.11	£38,183	12.03	7.43	£49,520	£7,147	£13,804
-10%	9.86	5.40	£30,793	11.50	6.26	£38,183	12.03	6.52	£49,520	£8,578	£16,621
-20%	9.86	4.80	£30,793	11.50	5.56	£38,183	12.03	5.80	£49,520	£9,650	£18,699
-30%	9.86	4.20	£30,793	11.50	4.87	£38,183	12.03	5.07	£49,520	£11,029	£21,370
Higher in PFS1 (+10%)	9.86	6.12	£30,793	11.50	7.27	£38,183	12.03	7.63	£49,520	£6,447	£12,395
No disutility	9.86	6.00	£30,793	11.50	6.96	£38,183	12.03	7.25	£49,520	£7,704	£14,928
Disutility = -10%	9.86	6.00	£30,793	11.50	6.95	£38,183	12.03	7.25	£49,520	£7,715	£14,949
Disutility = -20%	9.86	5.99	£30,793	11.50	6.95	£38,183	12.03	7.24	£49,520	£7,725	£14,969
Disutility = -30%	9.86	5.99	£30,793	11.50	6.95	£38,183	12.03	7.24	£49,520	£7,736	£14,990
Treatment pathway											
Second-line after progression	10.14	6.17	£30,228	11.60	7.01	£37,977	12.13	7.31	£49,315	£9,230	£16,828
R-CVP, no retreatment if early relapse	9.86	5.99	£30,793	11.31	6.83	£37,550	11.87	7.15	£49,026	£8,123	£15,816
Patients receive CHOP & R-CHOP instead of salvage HDT & R-HDT	9.86	5.99	£30,793	11.50	6.95	£38,183	12.03	7.25	£49,520	£7,720	£14,959
Patients receive CHOP & R-CHOP instead of FC & R-FC	10.11	6.14	£31,913	11.73	7.08	£39,172	12.24	7.36	£50,394	£7,742	£15,145
Last 3 scenarios	10.11	6.14	£31,913	11.52	6.94	£38,193	12.07	7.25	£49,636	£7,841	£15,919
All patients receive salvage with rituximab	12.14	7.14	£38,358	13.36	7.86	£44,421	13.72	8.07	£55,262	£8,506	£18,325

	CVP			R-CVP (base case)			R-CVP (scenario)			ICER – Cost per QALY gained	
	LY	QALY	Cost	LY	QALY	Cost	LY	QALY	Cost	Base case	Scenario
All patients receive salvage without rituximab	6.99	4.45	£28,838	9.18	5.74	£36,776	9.96	6.18	£48,402	£6,159	£11,273
All patients receive CHOP	9.36	5.67	£28,377	11.11	6.71	£36,174	11.71	7.05	£47,764	£7,553	£14,127
All patients receive R-CHOP	10.11	6.14	£31,913	11.73	7.08	£39,172	12.27	7.38	£50,519	£7,742	£15,034
Effectiveness of FC											
No loss of response	10.10	6.14	£31,188	11.73	7.08	£38,530	12.24	7.36	£49,834	£7,827	£15,271
Response 10% lower compared to CHOP regimens	9.98	6.07	£30,990	11.62	7.01	£38,358	12.13	7.30	£49,679	£7,776	£15,114
Response 30% lower compared to CHOP regimens	9.74	5.93	£30,598	11.39	6.89	£38,010	11.93	7.19	£49,362	£7,676	£14,832
Response 40% lower compared to CHOP regimens	9.61	5.85	£30,400	11.28	6.83	£37,840	11.82	7.14	£49,204	£7,615	£14,673
Response 50% lower compared to CHOP regimens	9.49	5.78	£30,212	11.17	6.77	£37,676	11.72	7.08	£49,056	£7,565	£14,523
PFS reduction -10%	9.72	5.92	£30,835	11.39	6.89	£38,223	11.92	7.19	£49,559	£7,625	£14,754
PFS reduction -20%	9.57	5.83	£30,870	11.25	6.81	£38,259	11.79	7.12	£49,593	£7,520	£14,525
PFS reduction -30%	9.39	5.73	£30,875	11.09	6.73	£38,270	11.64	7.04	£49,608	£7,409	£14,282
Costing of salvage therapy											
Response rate same as CHOP regimens	9.86	5.99	£30,793	11.50	6.95	£38,183	12.03	7.25	£49,520	£7,720	£14,959
Response rate 20% greater than CHOP regimens	9.86	5.99	£30,793	11.50	6.95	£38,183	12.03	7.25	£49,520	£7,720	£14,959
Response rate 30% greater than CHOP regimens	9.86	5.99	£30,793	11.50	6.95	£38,183	12.03	7.25	£49,520	£7,720	£14,959
Nb of cycle of ESHAP = 3	9.86	5.99	£30,793	11.50	6.95	£38,183	12.03	7.25	£49,520	£7,720	£14,959
Nb of cycle of ESHAP = 4	9.86	5.99	£30,793	11.50	6.95	£38,183	12.03	7.25	£49,520	£7,720	£14,959
Harvest success rate: 1	9.86	5.99	£30,793	11.50	6.95	£38,183	12.03	7.25	£49,520	£7,720	£14,959
Harvest success rate: 0.95	9.86	5.99	£30,793	11.50	6.95	£38,183	12.03	7.25	£49,520	£7,720	£14,959

	CVP			R-CVP (base case)			R-CVP (scenario)			ICER – Cost per QALY gained	
	LY	QALY	Cost	LY	QALY	Cost	LY	QALY	Cost	Base case	Scenario
Harvest success rate: 0.90	9.86	5.99	£30,793	11.50	6.95	£38,183	12.03	7.25	£49,520	£7,720	£14,959
Harvest success rate: 0.85	9.86	5.99	£30,793	11.50	6.95	£38,183	12.03	7.25	£49,520	£7,720	£14,959
Harvest success rate: 0.75	9.86	5.99	£30,793	11.50	6.95	£38,183	12.03	7.25	£49,520	£7,720	£14,959
Only one administration	9.86	5.99	£30,793	11.50	6.95	£38,183	12.03	7.25	£49,520	£7,720	£14,959
1 additional administration	9.86	5.99	£30,793	11.50	6.95	£38,183	12.03	7.25	£49,520	£7,720	£14,959
Adverse events											
No adverse events	9.86	6.00	£30,337	11.50	6.96	£37,390	12.03	7.25	£48,637	£7,353	£14,588
Costs + 20%	9.86	5.99	£30,884	11.50	6.95	£38,341	12.03	7.25	£49,697	£7,791	£15,027
Costs – 20%	9.86	5.99	£30,702	11.50	6.95	£38,024	12.03	7.25	£49,344	£7,650	£14,891
Nb of cycles											
6 cycles for CHOP	9.86	5.99	£30,793	11.50	6.95	£38,183	12.03	7.25	£49,520	£7,720	£14,959
6 cycles for FC	9.87	6.01	£32,540	11.52	6.96	£39,728	12.04	7.26	£50,926	£7,521	£14,714
Management costs											
Cost +20%	9.86	5.99	£31,730	11.50	6.95	£39,123	12.03	7.25	£50,962	£7,724	£15,362
Cost -20%	9.86	5.99	£29,856	11.50	6.95	£37,242	12.03	7.25	£48,078	£7,716	£14,556
Cost pharmacy = £35	9.86	5.99	£30,948	11.50	6.95	£38,459	12.03	7.25	£49,951	£7,847	£15,179
No monitoring costs	9.86	5.99	£28,037	11.50	6.95	£34,234	12.03	7.25	£46,450	£6,475	£14,708
Monitoring cost +20%	9.86	5.99	£31,344	11.50	6.95	£38,972	12.03	7.25	£50,134	£7,969	£15,009
Monitoring cost -20%	9.86	5.99	£30,242	11.50	6.95	£37,393	12.03	7.25	£48,906	£7,471	£14,909
No 3 rd line treatment costs	9.86	5.99	£26,933	11.50	6.95	£34,999	12.03	7.25	£46,495	£8,427	£15,626
No cost palliative care	9.86	5.99	£26,223	11.50	6.95	£34,564	12.03	7.25	£46,232	£8,715	£15,984

	CVP			R-CVP (base case)			R-CVP (scenario)			ICER – Cost per QALY gained	
	LY	QALY	Cost	LY	QALY	Cost	LY	QALY	Cost	Base case	Scenario
No terminal care costs	9.86	5.99	£29,000	11.50	6.95	£36,789	12.03	7.25	£48,253	£8,138	£15,379
No terminal or palliative care costs	9.86	5.99	£24,429	11.50	6.95	£33,170	12.03	7.25	£44,965	£9,132	£16,404
Maximum age at which aggressive therapy is given											
60 years	9.75	5.93	£30,441	11.41	6.90	£37,903	11.95	7.21	£49,281	£7,690	£14,821
70 years	9.95	6.05	£31,118	11.59	7.00	£38,465	12.10	7.29	£49,764	£7,735	£15,040
75 years	10.02	6.09	£31,419	11.65	7.03	£38,724	12.17	7.32	£49,993	£7,748	£15,117
80 years	10.07	6.12	£31,653	11.70	7.06	£38,929	12.21	7.34	£50,172	£7,747	£15,149
BSA											
1.6 m2	9.86	5.99	£28,432	11.50	6.95	£34,266	12.03	7.25	£43,586	£6,095	£12,105
1.7 m2	9.86	5.99	£30,110	11.50	6.95	£36,994	12.03	7.25	£47,684	£7,192	£14,038
1.8 m2	9.86	5.99	£30,110	11.50	6.95	£36,994	12.03	7.25	£47,684	£7,192	£14,038
1.9 m2	9.86	5.99	£31,550	11.50	6.95	£39,512	12.03	7.25	£51,584	£8,318	£16,003
Maximum time in PFS1											
5 years	9.68	5.90	£31,256	10.60	6.48	£40,882	10.79	6.60	£53,183	£16,656	£31,354
6 years	9.72	5.92	£31,170	10.74	6.56	£40,500	10.99	6.72	£52,669	£14,527	£27,043
7 years	9.74	5.94	£31,103	10.86	6.63	£40,182	11.16	6.81	£52,240	£13,044	£24,178
8 years	9.77	5.95	£31,051	10.97	6.69	£39,911	11.30	6.89	£51,873	£11,964	£22,151
9 years	9.78	5.96	£31,009	11.05	6.74	£39,682	11.41	6.95	£51,564	£11,143	£20,651
10 years	9.80	5.97	£30,975	11.13	6.78	£39,490	11.52	7.01	£51,301	£10,513	£19,516
11 years	9.81	5.97	£30,948	11.19	6.81	£39,326	11.60	7.05	£51,080	£10,016	£18,645
12 years	9.82	5.98	£30,926	11.25	6.84	£39,183	11.68	7.09	£50,885	£9,613	£17,951

	CVP			R-CVP (base case)			R-CVP (scenario)			ICER – Cost per QALY gained	
	LY	QALY	Cost	LY	QALY	Cost	LY	QALY	Cost	Base case	Scenario
13 years	9.82	5.98	£30,906	11.29	6.86	£39,058	11.74	7.12	£50,717	£9,287	£17,394
14 years	9.83	5.98	£30,890	11.33	6.88	£38,948	11.79	7.15	£50,568	£9,018	£16,944
15 years	9.84	5.99	£30,876	11.37	6.89	£38,854	11.84	7.17	£50,439	£8,797	£16,577
16 years	9.84	5.99	£30,864	11.40	6.91	£38,774	11.88	7.18	£50,329	£8,616	£16,274
17 years	9.84	5.99	£30,855	11.42	6.92	£38,701	11.91	7.20	£50,230	£8,461	£16,023
18 years	9.85	5.99	£30,846	11.44	6.93	£38,635	11.94	7.21	£50,141	£8,331	£15,815
19 years	9.85	5.99	£30,838	11.46	6.93	£38,576	11.97	7.22	£50,063	£8,223	£15,642
Greater OS for R-CHOP compared to CHOP											
5%	10.41	6.26	£31,444	11.95	7.16	£38,677	12.41	7.42	£49,930	£8,067	£15,969
10%	10.94	6.51	£32,043	12.37	7.35	£39,130	12.76	7.58	£50,307	£8,441	£17,080
15%	11.42	6.73	£32,572	12.74	7.52	£39,531	13.08	7.72	£50,638	£8,837	£18,263
20%	11.85	6.92	£33,033	13.07	7.66	£39,878	13.36	7.84	£50,924	£9,232	£19,489
25%	12.21	7.09	£33,424	13.36	7.79	£40,170	13.60	7.94	£51,163	£9,613	£20,696
Maintenance duration effect											
36 months	9.86	5.99	£30,793	11.50	6.95	£38,183	11.97	7.22	£49,684	£7,720	£15,469
48 months	9.86	5.99	£30,793	11.50	6.95	£38,183	12.08	7.27	£49,373	£7,720	£14,524
60 months	9.86	5.99	£30,793	11.50	6.95	£38,183	12.17	7.32	£49,115	£7,720	£13,828
72 months	9.86	5.99	£30,793	11.50	6.95	£38,183	12.24	7.36	£48,896	£7,720	£13,305
Hazard ratio maintenance											
0.48	9.86	5.99	£30,793	11.50	6.95	£38,183	12.13	7.31	£49,411	£7,720	£14,205
0.66	9.86	5.99	£30,793	11.50	6.95	£38,183	11.88	7.16	£49,676	£7,720	£16,210

Table 104: Sensitivity analyses for R-CHOP versus CHOP

	CHOP			R-CHOP (base case)			R-CHOP (scenario)			ICER – Cost per QALY gained	
	LY	QALY	Cost	LY	QALY	Cost	LY	QALY	Cost	Base case	Scenario
Base case	11.55	6.84	£34,983	12.40	7.37	£40,708	13.02	7.72	£54,134	£10,834	£21,687
Time horizon											
5 years	4.28	3.13	£25,929	4.44	3.25	£30,003	4.52	3.31	£42,241	£33,975	£91,356
10 years	7.19	4.90	£30,458	7.63	5.21	£35,660	7.90	5.40	£48,618	£16,650	£36,367
Lifetime	13.15	7.23	£35,994	14.07	7.78	£41,705	14.79	8.16	£55,183	£10,362	£20,533
Discounting											
0% costs, 0% benefits	11.55	9.01	£40,994	12.40	9.76	£47,222	13.02	10.28	£61,687	£8,306	£16,295
0% costs, 3.5% benefits	11.55	6.84	£40,994	12.40	7.37	£47,222	13.02	7.72	£61,687	£11,788	£23,434
3.5% costs, 0% benefits	11.55	9.01	£34,983	12.40	9.76	£40,708	13.02	10.28	£54,134	£7,634	£15,081
Parametric distribution											
Weibull	11.43	6.77	£35,483	12.16	7.25	£41,186	12.75	7.59	£55,009	£12,030	£23,824
Gompertz	11.72	6.92	£34,115	12.87	7.58	£36,733	13.80	8.09	£48,766	£3,941	£12,490
Death event in PFS											
none	12.04	7.11	£36,344	12.61	7.48	£41,296	13.21	7.82	£54,651	£13,463	£25,867
CVP arm	11.55	6.84	£34,983	12.25	7.28	£40,281	12.88	7.65	£53,759	£11,872	£23,141
R-CVP arm	11.76	6.95	£35,559	12.40	7.37	£40,708	13.02	7.72	£54,134	£12,470	£24,200
Resistance to rituximab											
-10%	11.55	6.84	£34,983	12.18	7.25	£40,769	12.82	7.62	£54,194	£13,843	£24,447
-15%	11.55	6.84	£34,983	12.06	7.19	£40,796	12.71	7.57	£54,220	£16,328	£26,301
-20%	11.55	6.84	£34,983	11.93	7.13	£40,814	12.59	7.51	£54,239	£20,163	£28,629

	CHOP			R-CHOP (base case)			R-CHOP (scenario)			ICER – Cost per QALY gained	
	LY	QALY	Cost	LY	QALY	Cost	LY	QALY	Cost	Base case	Scenario
-25%	11.55	6.84	£34,983	11.78	7.05	£40,822	12.46	7.45	£54,252	£26,939	£31,646
-30%	11.55	6.84	£34,983	11.62	6.97	£40,826	12.32	7.38	£54,260	£42,361	£35,734
Utility values											
PFS1 = 0.805; PFS2 = 0.805; PD = 0.7363	11.55	6.66	£34,983	12.40	7.45	£40,708	13.02	7.92	£54,134	£7,167	£15,113
PFS1 = 0.805; PFS2 = 0.805; PD = 0.7363	11.55	6.95	£34,983	12.40	7.55	£40,708	13.02	7.94	£54,134	£9,518	£19,354
-10%	11.55	6.15	£34,983	12.40	6.63	£40,708	13.02	6.95	£54,134	£12,038	£24,097
-20%	11.55	5.47	£34,983	12.40	5.89	£40,708	13.02	6.18	£54,134	£13,543	£27,109
-30%	11.55	4.79	£34,983	12.40	5.16	£40,708	13.02	5.40	£54,134	£15,478	£30,982
Higher in PFS1 (+10%)	11.55	7.02	£34,983	12.40	7.73	£40,708	13.02	8.17	£54,134	£8,019	£16,628
No disutility	11.55	6.87	£34,983	12.40	7.40	£40,708	13.02	7.75	£54,134	£10,760	£21,580
Disutility = -10%	11.55	6.85	£34,983	12.40	7.38	£40,708	13.02	7.73	£54,134	£10,809	£21,651
Disutility = -20%	11.55	6.83	£34,983	12.40	7.35	£40,708	13.02	7.71	£54,134	£10,860	£21,724
Disutility = -30%	11.55	6.81	£34,983	12.40	7.33	£40,708	13.02	7.69	£54,134	£10,910	£21,796
Treatment pathway											
Second-line after progression	11.60	6.87	£34,821	12.48	7.41	£40,765	13.10	7.76	£54,190	£10,945	£21,576
R-CVP, no retreatment if early relapse	11.55	6.84	£34,983	12.40	7.37	£40,708	13.02	7.72	£54,134	£10,834	£21,687
Patients receive CHOP & R-CHOP instead of salvage HDT & R-HDT	10.30	6.25	£31,905	11.83	7.12	£38,928	12.51	7.50	£52,598	£8,058	£16,517
Patients receive CHOP & R-CHOP instead of FC & R-FC	11.80	6.98	£36,067	12.61	7.48	£41,493	13.22	7.82	£54,882	£10,833	£22,251
Last 3 scenarios	10.54	6.39	£32,989	12.04	7.23	£39,713	12.70	7.60	£53,346	£7,967	£16,750
All patients receive salvage with rituximab	12.45	7.32	£39,045	13.63	8.00	£45,002	14.06	8.25	£57,917	£8,745	£20,293
All patients receive salvage without rituximab	7.60	4.81	£30,140	9.76	6.06	£37,961	10.68	6.59	£51,809	£6,245	£12,153

	CHOP			R-CHOP (base case)			R-CHOP (scenario)			ICER – Cost per QALY gained	
	LY	QALY	Cost	LY	QALY	Cost	LY	QALY	Cost	Base case	Scenario
All patients receive CHOP	9.83	5.95	£29,624	11.56	6.95	£37,321	12.27	7.35	£51,130	£7,714	£15,337
All patients receive R-CHOP	10.54	6.39	£32,989	12.13	7.29	£40,137	12.77	7.65	£53,656	£7,933	£16,436
Effectiveness of FC											
No loss of response	11.80	6.97	£35,363	12.61	7.48	£41,013	13.21	7.82	£54,415	£11,268	£22,509
Response 10% lower compared to CHOP regimens	11.67	6.91	£35,174	12.50	7.42	£40,861	13.11	7.77	£54,274	£11,045	£22,098
Response 30% lower compared to CHOP regimens	11.44	6.77	£34,790	12.30	7.31	£40,548	12.92	7.67	£53,986	£10,669	£21,348
Response 40% lower compared to CHOP regimens	11.31	6.70	£34,599	12.19	7.25	£40,390	12.82	7.62	£53,840	£10,489	£20,980
Response 50% lower compared to CHOP regimens	11.20	6.63	£34,420	12.09	7.20	£40,237	12.73	7.57	£53,706	£10,331	£20,622
PFS reduction -10%	11.42	6.76	£35,026	12.29	7.30	£40,744	12.91	7.66	£54,170	£10,582	£21,233
PFS reduction -20%	11.27	6.68	£35,061	12.15	7.23	£40,774	12.79	7.60	£54,200	£10,310	£20,733
PFS reduction -30%	11.10	6.58	£35,071	12.00	7.15	£40,784	12.65	7.53	£54,216	£10,019	£20,199
Costing of salvage therapy											
Response rate same as CHOP regimens	11.55	6.84	£34,216	12.40	7.37	£40,145	13.02	7.72	£53,652	£11,221	£22,011
Response rate 20% greater than CHOP regimens	11.55	6.84	£35,750	12.40	7.37	£41,271	13.02	7.72	£54,615	£10,448	£21,364
Response rate 30% greater than CHOP regimens	11.55	6.84	£36,043	12.40	7.37	£41,534	13.02	7.72	£54,834	£10,393	£21,281
Nb of cycle of ESHAP = 3	11.55	6.84	£36,271	12.40	7.37	£41,624	13.02	7.72	£54,921	£10,132	£21,121
Nb of cycle of ESHAP = 4	11.55	6.84	£37,558	12.40	7.37	£42,540	13.02	7.72	£55,708	£9,430	£20,555
Harvest success rate: 1	11.55	6.84	£37,093	12.40	7.37	£42,255	13.02	7.72	£55,457	£9,771	£20,798
Harvest success rate: 0.95	11.55	6.84	£36,565	12.40	7.37	£41,869	13.02	7.72	£55,126	£10,037	£21,020
Harvest success rate: 0.90	11.55	6.84	£36,038	12.40	7.37	£41,482	13.02	7.72	£54,796	£10,303	£21,243

	CHOP			R-CHOP (base case)			R-CHOP (scenario)			ICER – Cost per QALY gained	
	LY	QALY	Cost	LY	QALY	Cost	LY	QALY	Cost	Base case	Scenario
Harvest success rate: 0.85	11.55	6.84	£35,511	12.40	7.37	£41,095	13.02	7.72	£54,465	£10,569	£21,465
Harvest success rate: 0.75	11.55	6.84	£34,456	12.40	7.37	£40,321	13.02	7.72	£53,803	£11,100	£21,910
Only one administration	11.55	6.84	£34,349	12.40	7.37	£40,224	13.02	7.72	£53,722	£11,119	£21,940
1 additional administration	11.55	6.84	£34,561	12.40	7.37	£40,385	13.02	7.72	£53,859	£11,024	£21,856
Adverse events											
No adverse events	11.55	6.87	£34,028	12.40	7.40	£39,604	13.02	7.75	£52,920	£10,479	£21,288
Costs + 20%	11.55	6.84	£35,174	12.40	7.37	£40,929	13.02	7.72	£54,376	£10,891	£21,746
Costs – 20%	11.55	6.84	£34,792	12.40	7.37	£40,487	13.02	7.72	£53,891	£10,778	£21,629
Nb of cycles											
6 cycles for CHOP	11.51	6.81	£34,234	12.27	7.29	£37,122	12.93	7.67	£50,718	£5,951	£19,092
6 cycles for FC	11.57	6.85	£36,680	12.42	7.37	£42,054	13.03	7.73	£55,398	£10,206	£21,261
Management costs											
Cost +20%	11.55	6.84	£35,813	12.40	7.37	£41,550	13.02	7.72	£55,591	£10,859	£22,398
Cost -20%	11.55	6.84	£34,154	12.40	7.37	£39,865	13.02	7.72	£52,677	£10,810	£20,977
Cost pharmacy = £35	11.55	6.84	£35,062	12.40	7.37	£40,921	13.02	7.72	£54,545	£11,089	£22,064
No monitoring costs	11.55	6.84	£31,292	12.40	7.37	£36,160	13.02	7.72	£50,627	£9,214	£21,897
Monitoring cost +20%	11.55	6.84	£35,722	12.40	7.37	£41,617	13.02	7.72	£54,835	£11,159	£21,646
Monitoring cost -20%	11.55	6.84	£34,245	12.40	7.37	£39,798	13.02	7.72	£53,432	£10,510	£21,729
No 3 rd line treatment costs	11.55	6.84	£33,111	12.40	7.37	£38,881	13.02	7.72	£52,501	£10,921	£21,960
No cost palliative care	11.55	6.84	£29,502	12.40	7.37	£36,764	13.02	7.72	£50,769	£13,744	£24,085
No terminal care costs	11.55	6.84	£33,549	12.40	7.37	£39,521	13.02	7.72	£53,100	£11,303	£22,141

	CHOP			R-CHOP (base case)			R-CHOP (scenario)			ICER – Cost per QALY gained	
	LY	QALY	Cost	LY	QALY	Cost	LY	QALY	Cost	Base case	Scenario
No terminal or palliative care costs	11.55	6.84	£28,067	12.40	7.37	£35,577	13.02	7.72	£49,735	£14,213	£24,538
Maximum age at which aggressive therapy is given											
60 years	11.13	6.63	£33,780	12.16	7.25	£39,946	12.81	7.62	£53,470	£9,832	£19,745
70 years	11.90	7.02	£36,129	12.63	7.47	£41,530	13.24	7.82	£54,886	£11,758	£23,230
75 years	12.17	7.16	£37,152	12.80	7.56	£42,270	13.40	7.90	£55,592	£12,763	£24,704
80 years	12.33	7.25	£37,973	12.91	7.61	£42,906	13.52	7.96	£56,187	£13,377	£25,559
BSA											
1.6 m2	11.55	6.84	£33,716	12.40	7.37	£37,617	13.02	7.72	£48,435	£7,384	£16,669
1.7 m2	11.55	6.84	£34,665	12.40	7.37	£39,796	13.02	7.72	£52,385	£9,712	£20,067
1.8 m2	11.55	6.84	£34,665	12.40	7.37	£39,796	13.02	7.72	£52,385	£9,712	£20,067
1.9 m2	11.55	6.84	£35,378	12.40	7.37	£41,768	13.02	7.72	£56,143	£12,094	£23,517
Maximum time in PFS1											
5 years	11.33	6.71	£35,877	11.56	6.91	£44,464	11.86	7.09	£59,233	£43,733	£61,115
6 years	11.37	6.74	£35,698	11.69	6.99	£43,896	12.03	7.20	£58,465	£32,857	£49,043
7 years	11.41	6.76	£35,567	11.79	7.05	£43,429	12.18	7.29	£57,834	£26,749	£41,756
8 years	11.43	6.78	£35,462	11.88	7.11	£43,038	12.31	7.37	£57,300	£22,835	£36,904
9 years	11.45	6.79	£35,379	11.96	7.15	£42,708	12.42	7.43	£56,854	£20,149	£33,528
10 years	11.47	6.80	£35,312	12.03	7.19	£42,428	12.51	7.48	£56,474	£18,210	£31,050
11 years	11.49	6.81	£35,262	12.09	7.22	£42,202	12.59	7.52	£56,167	£16,745	£29,166
12 years	11.50	6.81	£35,220	12.14	7.25	£42,006	12.66	7.56	£55,900	£15,607	£27,698
13 years	11.51	6.82	£35,184	12.19	7.27	£41,837	12.72	7.59	£55,673	£14,718	£26,544

	CHOP			R-CHOP (base case)			R-CHOP (scenario)			ICER – Cost per QALY gained	
	LY	QALY	Cost	LY	QALY	Cost	LY	QALY	Cost	Base case	Scenario
14 years	11.52	6.82	£35,153	12.23	7.29	£41,686	12.78	7.61	£55,470	£13,999	£25,615
15 years	11.53	6.82	£35,128	12.26	7.30	£41,559	12.82	7.64	£55,298	£13,427	£24,869
16 years	11.53	6.83	£35,106	12.29	7.32	£41,454	12.86	7.65	£55,152	£12,963	£24,252
17 years	11.54	6.83	£35,089	12.31	7.33	£41,359	12.90	7.67	£55,024	£12,576	£23,746
18 years	11.54	6.83	£35,074	12.34	7.34	£41,275	12.93	7.68	£54,910	£12,256	£23,326
19 years	11.55	6.83	£35,060	12.35	7.35	£41,201	12.95	7.69	£54,811	£11,995	£22,985
Greater OS for R-CHOP compared to CHOP											
5%	11.71	6.91	£35,155	12.52	7.42	£40,825	13.13	7.77	£54,241	£11,213	£22,292
10%	11.85	6.98	£35,308	12.62	7.47	£40,930	13.23	7.81	£54,337	£11,588	£22,876
15%	11.97	7.04	£35,439	12.71	7.51	£41,022	13.31	7.85	£54,420	£11,950	£23,415
20%	12.08	7.09	£35,553	12.79	7.54	£41,099	13.39	7.89	£54,490	£12,283	£23,910
25%	12.17	7.14	£35,645	12.86	7.57	£41,164	13.45	7.91	£54,549	£12,565	£24,323
Maintenance duration effect											
36 months	11.55	6.84	£34,983	12.40	7.37	£40,708	12.97	7.69	£54,364	£10,834	£22,703
48 months	11.55	6.84	£34,983	12.40	7.37	£40,708	13.07	7.75	£53,931	£10,834	£20,827
60 months	11.55	6.84	£34,983	12.40	7.37	£40,708	13.15	7.79	£53,572	£10,834	£19,478
72 months	11.55	6.84	£34,983	12.40	7.37	£40,708	13.22	7.83	£53,276	£10,834	£18,495
Hazard ratio maintenance											
0.48	11.55	6.84	£34,983	12.40	7.37	£40,708	13.13	7.78	£53,961	£10,834	£20,051
0.66	11.55	6.84	£34,983	12.40	7.37	£40,708	12.85	7.62	£54,390	£10,834	£24,628

Table 105: Sensitivity analyses for R-MCP versus MCP

	MCP			R-MCP (base case)			R-MCP (scenario)			ICER – Cost per QALY gained	
	LY	QALY	Cost	LY	QALY	Cost	LY	QALY	Cost	Base case	Scenario
Base case	11.45	6.79	£36,103	12.35	7.36	£41,370	12.89	7.67	£54,079	£9,316	£20,493
Time horizon											
5 years	4.25	3.12	£27,233	4.43	3.26	£30,660	4.49	3.31	£42,324	£24,366	£80,497
10 years	7.12	4.87	£31,621	7.61	5.22	£36,341	7.84	5.38	£48,633	£13,598	£33,482
Lifetime	13.04	7.18	£37,112	13.99	7.76	£42,361	14.63	8.10	£55,109	£8,963	£19,510
Discounting											
0% costs, 0% benefits	11.45	8.94	£42,032	12.35	9.73	£47,913	12.89	10.19	£61,663	£7,416	£15,677
0% costs, 3.5% benefits	11.45	6.79	£42,032	12.35	7.36	£47,913	12.89	7.67	£61,663	£10,401	£22,379
3.5% costs, 0% benefits	11.45	8.94	£36,103	12.35	9.73	£41,370	12.89	10.19	£54,079	£6,643	£14,356
Parametric distribution											
Weibull	11.35	6.74	£36,499	12.11	7.24	£41,822	12.63	7.54	£54,903	£10,594	£22,833
Gompertz	11.59	6.85	£35,367	12.82	7.57	£37,623	13.64	8.02	£48,991	£3,146	£11,653
Death event in PFS											
none	11.95	7.07	£37,490	12.56	7.47	£41,961	13.08	7.77	£54,602	£11,192	£24,562
CVP arm	11.45	6.79	£36,103	12.19	7.27	£40,942	12.75	7.60	£53,702	£10,023	£21,849
R-CVP arm	11.67	6.91	£36,690	12.35	7.36	£41,370	12.89	7.67	£54,079	£10,457	£22,899
Resistance to rituximab											
-10%	11.45	6.79	£36,103	12.13	7.24	£41,432	12.70	7.57	£54,140	£11,718	£23,067
-15%	11.45	6.79	£36,103	12.00	7.18	£41,457	12.59	7.52	£54,165	£13,632	£24,788

	MCP			R-MCP (base case)			R-MCP (scenario)			ICER – Cost per QALY gained	
	LY	QALY	Cost	LY	QALY	Cost	LY	QALY	Cost	Base case	Scenario
-20%	11.45	6.79	£36,103	11.87	7.12	£41,476	12.47	7.46	£54,184	£16,494	£26,946
-25%	11.45	6.79	£36,103	11.73	7.04	£41,483	12.34	7.40	£54,195	£21,253	£29,731
-30%	11.45	6.79	£36,103	11.57	6.96	£41,485	12.20	7.33	£54,203	£30,902	£33,489
Utility values											
PFS1 = 0.805; PFS2 = 0.805; PD = 0.7363	11.45	6.59	£36,103	12.35	7.44	£41,370	12.89	7.86	£54,079	£6,165	£14,092
PFS1 = 0.805; PFS2 = 0.805; PD = 0.7363	11.45	6.89	£36,103	12.35	7.54	£41,370	12.89	7.88	£54,079	£8,186	£18,216
-10%	11.45	6.11	£36,103	12.35	6.62	£41,370	12.89	6.90	£54,079	£10,352	£22,770
-20%	11.45	5.43	£36,103	12.35	5.88	£41,370	12.89	6.13	£54,079	£11,646	£25,616
-30%	11.45	4.75	£36,103	12.35	5.15	£41,370	12.89	5.37	£54,079	£13,309	£29,275
Higher in PFS1 (+10%)	11.45	6.96	£36,103	12.35	7.72	£41,370	12.89	8.11	£54,079	£6,898	£15,572
No disutility	11.45	6.80	£36,103	12.35	7.37	£41,370	12.89	7.68	£54,079	£9,291	£20,440
Disutility = -10%	11.45	6.79	£36,103	12.35	7.36	£41,370	12.89	7.67	£54,079	£9,308	£20,475
Disutility = -20%	11.45	6.79	£36,103	12.35	7.35	£41,370	12.89	7.66	£54,079	£9,325	£20,510
Disutility = -30%	11.45	6.78	£36,103	12.35	7.34	£41,370	12.89	7.65	£54,079	£9,342	£20,546
Treatment pathway											
Second-line after progression	11.57	6.86	£35,693	12.49	7.44	£41,475	13.03	7.75	£54,184	£10,125	£20,944
R-CVP, no retreatment if early relapse	11.45	6.79	£36,103	12.35	7.36	£41,370	12.89	7.67	£54,079	£9,316	£20,493
Patients receive CHOP & R-CHOP instead of salvage HDT & R-HDT	10.16	6.18	£32,938	11.79	7.11	£39,588	12.42	7.47	£52,589	£7,155	£15,261
Patients receive CHOP & R-CHOP instead of FC & R-FC	11.70	6.93	£37,204	12.56	7.47	£42,157	13.08	7.77	£54,811	£9,232	£21,026
Last 3 scenarios	10.41	6.33	£34,038	12.00	7.23	£40,374	12.62	7.57	£53,321	£7,035	£15,452
All patients receive salvage with rituximab	12.36	7.28	£40,209	13.61	8.00	£45,717	14.02	8.24	£58,020	£7,574	£18,491

	MCP			R-MCP (base case)			R-MCP (scenario)			ICER – Cost per QALY gained	
	LY	QALY	Cost	LY	QALY	Cost	LY	QALY	Cost	Base case	Scenario
All patients receive salvage without rituximab	7.41	4.71	£31,113	9.70	6.05	£38,621	10.59	6.55	£51,811	£5,604	£11,227
All patients receive CHOP	9.69	5.88	£30,613	11.52	6.95	£37,990	12.19	7.33	£51,144	£6,907	£14,146
All patients receive R-CHOP	10.41	6.33	£34,038	12.10	7.29	£40,820	12.70	7.63	£53,697	£7,041	£15,111
Effectiveness of FC											
No loss of response	11.70	6.93	£36,492	12.56	7.47	£41,678	13.08	7.77	£54,360	£9,655	£21,314
Response 10% lower compared to CHOP regimens	11.58	6.86	£36,299	12.45	7.41	£41,525	12.98	7.72	£54,218	£9,487	£20,916
Response 30% lower compared to CHOP regimens	11.34	6.72	£35,911	12.24	7.30	£41,213	12.79	7.62	£53,935	£9,188	£20,156
Response 40% lower compared to CHOP regimens	11.21	6.65	£35,717	12.14	7.24	£41,055	12.69	7.56	£53,789	£9,027	£19,783
Response 50% lower compared to CHOP regimens	11.09	6.58	£35,535	12.03	7.19	£40,903	12.60	7.52	£53,653	£8,896	£19,442
PFS reduction -10%	11.32	6.72	£36,146	12.23	7.29	£41,409	12.78	7.61	£54,117	£9,101	£20,050
PFS reduction -20%	11.17	6.63	£36,182	12.10	7.22	£41,438	12.66	7.55	£54,145	£8,865	£19,558
PFS reduction -30%	10.99	6.53	£36,192	11.95	7.14	£41,447	12.52	7.47	£54,159	£8,608	£19,031
Costing of salvage therapy											
Response rate same as CHOP regimens	11.45	6.79	£35,317	12.35	7.36	£40,803	12.89	7.67	£53,591	£9,704	£20,833
Response rate 20% greater than CHOP regimens	11.45	6.79	£36,890	12.35	7.36	£41,938	12.89	7.67	£54,567	£8,929	£20,152
Response rate 30% greater than CHOP regimens	11.45	6.79	£37,189	12.35	7.36	£42,206	12.89	7.67	£54,798	£8,874	£20,074
Nb of cycle of ESHAP = 3	11.45	6.79	£37,423	12.35	7.36	£42,293	12.89	7.67	£54,872	£8,613	£19,892
Nb of cycle of ESHAP = 4	11.45	6.79	£38,743	12.35	7.36	£43,215	12.89	7.67	£55,665	£7,910	£19,292
Harvest success rate: 1	11.45	6.79	£38,266	12.35	7.36	£42,931	12.89	7.67	£55,421	£8,251	£19,557
Harvest success rate: 0.95	11.45	6.79	£37,725	12.35	7.36	£42,541	12.89	7.67	£55,086	£8,517	£19,791

	MCP			R-MCP (base case)			R-MCP (scenario)			ICER – Cost per QALY gained	
	LY	QALY	Cost	LY	QALY	Cost	LY	QALY	Cost	Base case	Scenario
Harvest success rate: 0.90	11.45	6.79	£37,184	12.35	7.36	£42,151	12.89	7.67	£54,750	£8,784	£20,025
Harvest success rate: 0.85	11.45	6.79	£36,644	12.35	7.36	£41,761	12.89	7.67	£54,415	£9,050	£20,259
Harvest success rate: 0.75	11.45	6.79	£35,562	12.35	7.36	£40,980	12.89	7.67	£53,744	£9,583	£20,727
Only one administration	11.45	6.79	£35,453	12.35	7.36	£40,882	12.89	7.67	£53,659	£9,601	£20,755
1 additional administration	11.45	6.79	£35,670	12.35	7.36	£41,045	12.89	7.67	£53,799	£9,506	£20,667
Adverse events											
No adverse events	11.45	6.80	£35,996	12.35	7.37	£41,287	12.89	7.68	£53,892	£9,331	£20,348
Costs + 20%	11.45	6.79	£36,124	12.35	7.36	£41,387	12.89	7.67	£54,117	£9,308	£20,511
Costs – 20%	11.45	6.79	£36,082	12.35	7.36	£41,354	12.89	7.67	£54,042	£9,324	£20,474
Nb of cycles											
6 cycles for CHOP	11.45	6.79	£36,103	12.35	7.36	£41,370	12.89	7.67	£54,079	£9,316	£20,493
6 cycles for FC	11.47	6.80	£37,814	12.36	7.36	£42,718	12.90	7.68	£55,334	£8,704	£20,036
Management costs											
Cost +20%	11.45	6.79	£37,328	12.35	7.36	£42,626	12.89	7.67	£55,919	£9,370	£21,194
Cost -20%	11.45	6.79	£34,878	12.35	7.36	£40,115	12.89	7.67	£52,239	£9,263	£19,792
Cost pharmacy = £35	11.45	6.79	£36,182	12.35	7.36	£41,581	12.89	7.67	£54,478	£9,549	£20,856
No monitoring costs	11.45	6.79	£32,666	12.35	7.36	£36,963	12.89	7.67	£50,675	£7,600	£20,529
Monitoring cost +20%	11.45	6.79	£36,790	12.35	7.36	£42,252	12.89	7.67	£54,760	£9,660	£20,485
Monitoring cost -20%	11.45	6.79	£35,416	12.35	7.36	£40,489	12.89	7.67	£53,398	£8,973	£20,500
No 3 rd line treatment costs	11.45	6.79	£34,209	12.35	7.36	£39,531	12.89	7.67	£52,404	£9,413	£20,742
No cost palliative care	11.45	6.79	£30,484	12.35	7.36	£37,397	12.89	7.67	£50,677	£12,228	£23,020

	MCP			R-MCP (base case)			R-MCP (scenario)			ICER – Cost per QALY gained	
	LY	QALY	Cost	LY	QALY	Cost	LY	QALY	Cost	Base case	Scenario
No terminal care costs	11.45	6.79	£34,645	12.35	7.36	£40,170	12.89	7.67	£53,016	£9,773	£20,944
No terminal or palliative care costs	11.45	6.79	£29,025	12.35	7.36	£36,197	12.89	7.67	£49,614	£12,684	£23,471
Maximum age at which aggressive therapy is given											
60 years	11.02	6.57	£34,868	12.12	7.25	£40,617	12.69	7.58	£53,433	£8,528	£18,492
70 years	11.81	6.97	£37,258	12.58	7.47	£42,200	13.10	7.77	£54,815	£9,973	£22,116
75 years	12.08	7.11	£38,306	12.75	7.55	£42,941	13.26	7.84	£55,512	£10,659	£23,667
80 years	12.24	7.21	£39,134	12.86	7.61	£43,574	13.37	7.89	£56,099	£11,099	£24,650
BSA											
1.6 m2	11.45	6.79	£35,051	12.35	7.36	£38,536	12.89	7.67	£48,769	£6,164	£15,638
1.7 m2	11.45	6.79	£35,855	12.35	7.36	£40,541	12.89	7.67	£52,455	£8,289	£18,925
1.8 m2	11.45	6.79	£35,855	12.35	7.36	£40,541	12.89	7.67	£52,455	£8,289	£18,925
1.9 m2	11.45	6.79	£36,427	12.35	7.36	£42,346	12.89	7.67	£55,957	£10,469	£22,264
Maximum time in PFS1											
5 years	11.26	6.68	£36,843	11.52	6.91	£45,008	11.75	7.05	£59,088	£36,602	£60,170
6 years	11.30	6.71	£36,694	11.64	6.99	£44,454	11.92	7.16	£58,329	£27,820	£47,647
7 years	11.33	6.72	£36,585	11.75	7.05	£44,001	12.07	7.25	£57,706	£22,799	£40,277
8 years	11.35	6.74	£36,497	11.84	7.10	£43,621	12.20	7.32	£57,181	£19,527	£35,414
9 years	11.37	6.75	£36,429	11.92	7.15	£43,302	12.30	7.38	£56,742	£17,277	£32,065
10 years	11.39	6.76	£36,375	11.98	7.18	£43,032	12.39	7.43	£56,369	£15,642	£29,618
11 years	11.40	6.76	£36,333	12.04	7.21	£42,813	12.47	7.47	£56,066	£14,403	£27,766
12 years	11.41	6.77	£36,299	12.09	7.24	£42,623	12.54	7.51	£55,804	£13,437	£26,330

	MCP			R-MCP (base case)			R-MCP (scenario)			ICER – Cost per QALY gained	
	LY	QALY	Cost	LY	QALY	Cost	LY	QALY	Cost	Base case	Scenario
13 years	11.42	6.77	£36,268	12.14	7.26	£42,461	12.60	7.54	£55,582	£12,685	£25,206
14 years	11.43	6.78	£36,243	12.18	7.28	£42,316	12.65	7.56	£55,383	£12,074	£24,305
15 years	11.43	6.78	£36,221	12.21	7.30	£42,194	12.70	7.59	£55,216	£11,584	£23,580
16 years	11.44	6.78	£36,204	12.24	7.31	£42,092	12.74	7.60	£55,072	£11,188	£22,984
17 years	11.44	6.78	£36,190	12.26	7.32	£42,001	12.77	7.62	£54,947	£10,855	£22,496
18 years	11.44	6.79	£36,177	12.28	7.33	£41,919	12.80	7.63	£54,836	£10,579	£22,089
19 years	11.45	6.79	£36,167	12.30	7.34	£41,849	12.82	7.64	£54,740	£10,352	£21,758
Greater OS for R-CHOP compared to CHOP											
5%	11.61	6.87	£36,277	12.46	7.41	£41,489	12.99	7.72	£54,185	£9,620	£21,106
10%	11.75	6.94	£36,433	12.57	7.46	£41,594	13.09	7.76	£54,280	£9,918	£21,704
15%	11.88	7.00	£36,565	12.66	7.50	£41,686	13.18	7.80	£54,361	£10,208	£22,261
20%	11.99	7.05	£36,680	12.74	7.54	£41,764	13.25	7.83	£54,431	£10,468	£22,766
25%	12.08	7.09	£36,773	12.81	7.57	£41,830	13.31	7.86	£54,488	£10,691	£23,191
Maintenance duration effect											
36 months	11.45	6.79	£36,103	12.35	7.36	£41,370	12.84	7.64	£54,299	£9,316	£21,436
48 months	11.45	6.79	£36,103	12.35	7.36	£41,370	12.93	7.69	£53,884	£9,316	£19,712
60 months	11.45	6.79	£36,103	12.35	7.36	£41,370	13.01	7.73	£53,546	£9,316	£18,470
72 months	11.45	6.79	£36,103	12.35	7.36	£41,370	13.08	7.77	£53,263	£9,316	£17,547
Hazard ratio maintenance											
0.48	11.45	6.79	£36,103	12.35	7.36	£41,370	12.99	7.72	£53,898	£9,316	£19,063
0.66	11.45	6.79	£36,103	12.35	7.36	£41,370	12.74	7.58	£54,338	£9,316	£23,044

Appendix 16: Additional results for the scenario analysis incorporating first-line maintenance

Figure 57: Scenario analysis: Undiscounted life years

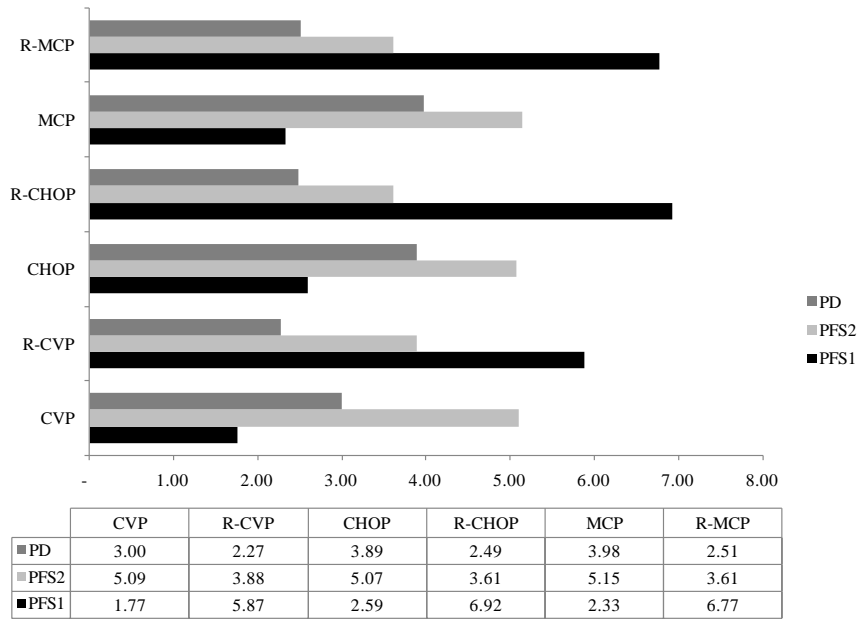

Undiscounted Life Years

Figure 58: Scenario analysis: Discounted QALYs

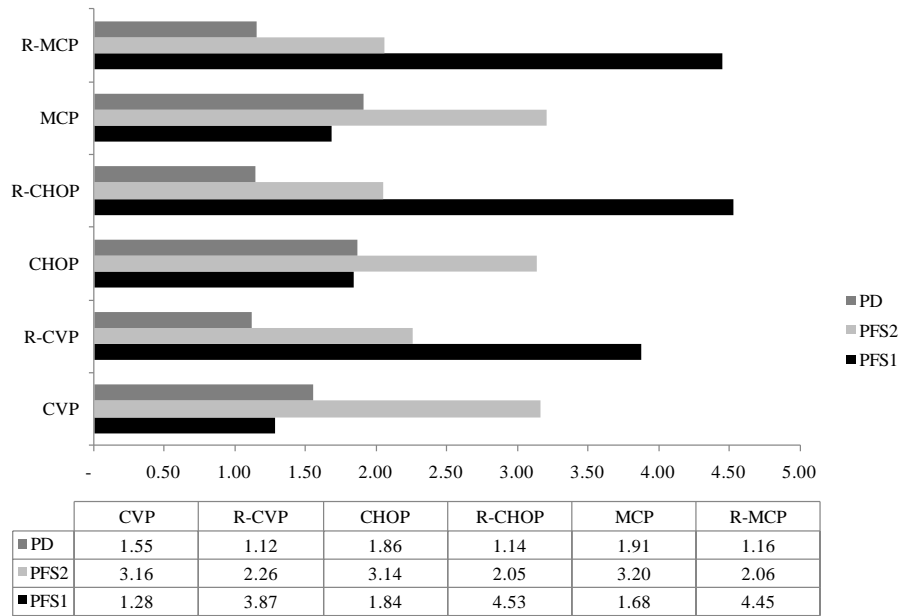

Discounted QALYs

Figure 59: Scenario analysis: Management and treatment costs for patients treated with CVP in first-line induction with or without rituximab

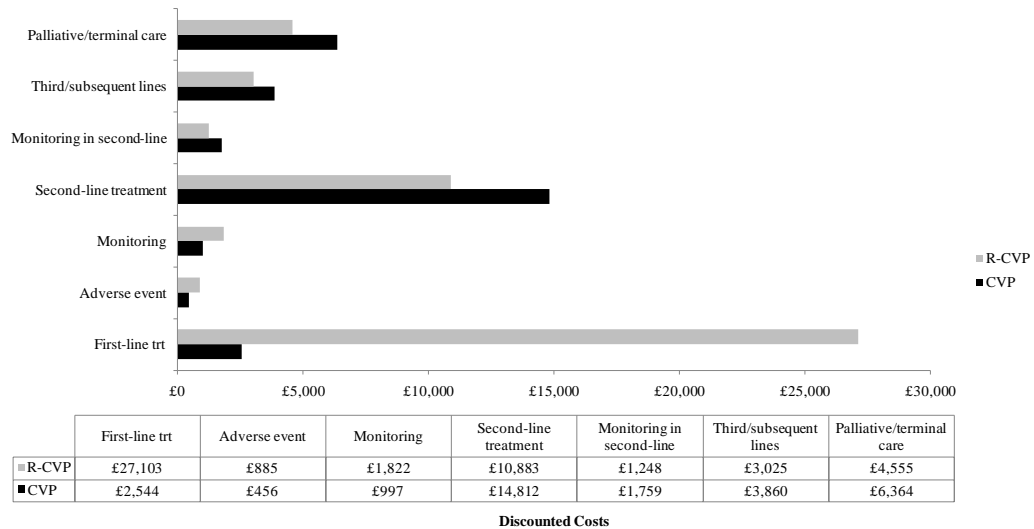

Figure 60: Scenario analysis: Management and treatment costs for patients treated with CHOP in first-line induction with or without rituximab

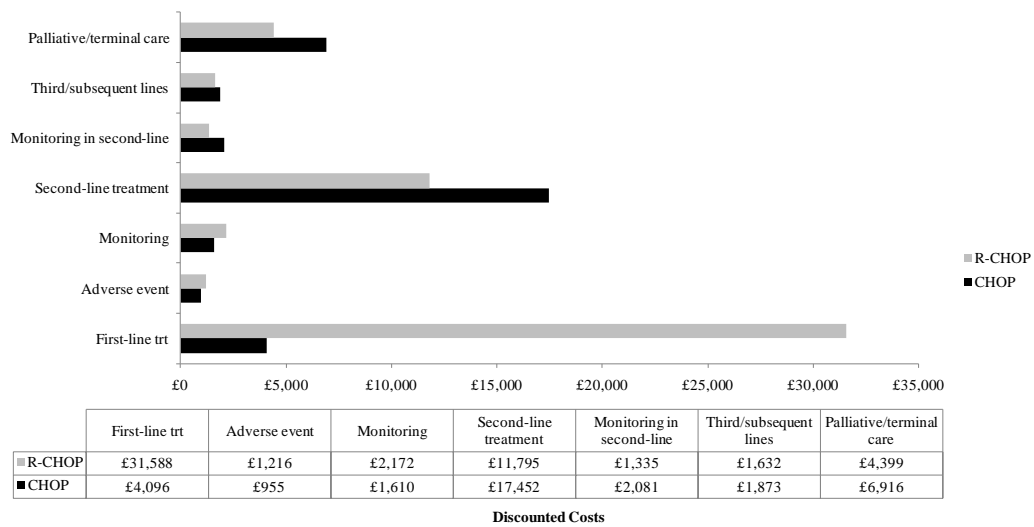
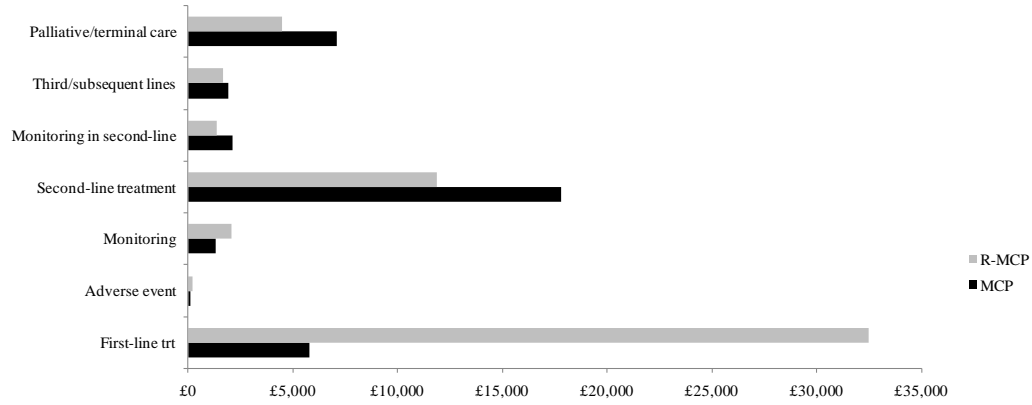

Figure 61: Scenario analysis: Management and treatment costs for patients treated with MCP in first-line induction with or without rituximab



	First-line trt	Adverse event	Monitoring	Second-line treatment	Monitoring in second-line	Third/subsequent lines	Palliative/terminal care
R-MCP	£32,483	£190	£2,065	£11,863	£1,339	£1,676	£4,465
MCP	£5,791	£107	£1,311	£17,797	£2,125	£1,894	£7,078

Discounted Costs

REFERENCES

1. Cancer Research UK. Cancer in the UK : July 2010. URL:
http://info.cancerresearchuk.org/prod_consump/groups/cr_common/@nre/@sta/documents/generalcontent/018070.pdf Accessed 2011.
2. Cancer Research UK. Non-Hodgkin lymphoma (NHL) statistics - Key Facts. URL: <http://info.cancerresearchuk.org/cancerstats/types/nhl/> Accessed 2011.
3. Office for National Statistics. Cancer statistics registrations: Registrations of cancer diagnosed in 2008, England. URL:
http://www.statistics.gov.uk/downloads/theme_health/mb1-39/mb1-no39-2008.pdf Accessed 2011.
4. Cancer Research UK Non-Hodgkin lymphoma - UK mortality statistics. <http://info.cancerresearchuk.org/cancerstats/types/nhl/mortality/> Accessed 2011.
5. Rohatiner, A. Z. and Lister, T. A. The clinical course of follicular lymphoma. *Best Practice and Research Clinical Haematology*. 2005; **18** 1-10.
6. Armitage, J. O. and Weisenburger, D. D. New approach to classifying non-Hodgkin's lymphomas: clinical features of the major histologic subtypes. Non-Hodgkin's Lymphoma Classification Project. *Journal of Clinical Oncology*. 1998; **16** 2780-2795.
7. The Non-Hodgkin's Lymphoma Classification Project. A clinical evaluation of the International Lymphoma Study Group classification of non-Hodgkin's lymphoma. *Blood* 1997; **89** 3909-3918.
8. Macmillan Cancer Support. Follicular lymphoma. 2009. URL:
http://www.macmillan.org.uk/Cancerinformation/Cancertypes/Lymphomanon-Hodgkin/TypesofNHL/Follicular.aspx#DynamicJumpMenuManager_6_Anchor_2 Accessed 2011.
9. Cancer Research UK. Outlook for low grade lymphomas. URL:
<http://www.cancerhelp.org.uk/type/non-hodgkins-lymphoma/treatment/statistics-and-outlook-for-non-hodgkins-lymphoma#low> Accessed 2011.

10. Cancer Research UK. UK Non-Hodgkin lymphoma (NHL) statistics. Cancer Statistics. URL:
<http://info.cancerresearchuk.org/cancerstats/types/nhl/incidence/> Accessed 2011
11. Freytes, C O and Burzynski, J A. Lymphoma, Follicular. 2009. URL:
<http://emedicine.medscape.com/article/203268-overview> Accessed 2011.
12. Tan, D, Rosenberg, S. A., Levy, R, Lavori, R, Tibshiranio, R, Hoppe, R. T. *et al.* Survival in Follicular Lymphoma. The Stanford Experience, 1960-2003. *Blood* 2007; **110** 3428A-
13. Tan, D, Rosenberg, S. A., Slava, B, Levy, R, Lavori, R, Hoppe, R. T., and Warnke, R. A. Closing the gap: A comparison of observed versus expected survival in follicular lymphoma at Stanford University from 1960-2003. *Journal of Clinical Oncology* 2008; **26 suppl**
14. Fisher, R. I., LeBlanc, M., Press, O. W., Maloney, D. G., Unger, J. M., and Miller, T. P. New treatment options have changed the survival of patients with follicular lymphoma. *Journal of Clinical Oncology* 20-11-2005; **23** 8447-8452.
15. Liu, Q., Fayad, L., Cabanillas, F., Hagemester, F. B., Ayers, G. D., Hess, M., *et al.* Improvement of overall and failure-free survival in stage IV follicular lymphoma: 25 years of treatment experience at The University of Texas M.D. Anderson Cancer Center. *Journal of Clinical Oncology* 1-4-2006; **24** 1582-1589.
16. National Cancer Intelligence Network (NCIN). One, Five and Ten Year Cancer Prevalence. 2010. URL:
<http://www.ncin.org.uk/publications/reports/default.aspx> Accessed 2011.
17. Cancer Research UK. Non-Hodgkin lymphoma - UK incidence statistics: Trends over time. URL:
<http://info.cancerresearchuk.org/cancerstats/types/nhl/incidence/#trends>
Accessed 2011

18. Dreyling, M. Newly diagnosed and relapsed follicular lymphoma: ESMO Clinical Practice Guidelines for diagnosis, treatment and follow-up. *Annals of Oncology*. 2010; **21 Suppl 5** v181-v183.
19. Fisher, S. G. and Fisher, R. I. The epidemiology of non-Hodgkin's lymphoma. *Oncogene* 23-8-2004; **23** 6524-6534.
20. Serraino, D., Salamina, G., Franceschi, S., Dubois, D., La, Vecchia C., Brunet, J. B., and Ancelle-Park, R. A. The epidemiology of AIDS-associated non-Hodgkin's lymphoma in the World Health Organization European Region. *British Journal of Cancer* 1992; **66** 912-916.
21. Ioachim, H. L. Neoplasms associated with immune deficiencies. *Pathology Annual* 1987; **22 Pt 2** 177-222.
22. Kersey, J. H., Shapiro, R. S., and Filipovich, A. H. Relationship of immunodeficiency to lymphoid malignancy. *Pediatric Infectious Disease Journal* 1988; **7 S10-S12**.
23. Cartwright, R A and McNally, R J Q. Epidemiology of non-Hodgkin's lymphoma *Hematology Oncology* 1994; **3** 1-34.
24. Filipovich, A. H., Mathur, A., Kamat, D., and Shapiro, R. S. Primary immunodeficiencies: genetic risk factors for lymphoma. *Cancer Research*. 1992; **52** 5465s-5467s.
25. Skarin, A. T. and Dorfman, D. M. Non-Hodgkin's lymphomas: current classification and management. *C: A Cancer Journal for Clinicians*. 1997; **47** 351-372.
26. British Committee for Standards in Haematology Guidelines on diagnosis and therapy: Nodal non-Hodgkin's lymphoma. 2003. URL: http://www.bcshguidelines.com/documents/nodal_NHL_bcsh_2003.pdf Accessed 2011.
27. Solal-Celigny, P., Roy, P., Colombat, P., White, J., Armitage, J. O., Arranz-Saez, R. *et al*. Follicular lymphoma international prognostic index. *Blood* 1-9-2004; **104** 1258-1265.

28. Horning, S. J. Natural history of and therapy for the indolent non-Hodgkin's lymphomas. *Seminars in Oncology*. 1993; **20** 75-88.
29. Gallagher, C. J., Gregory, W. M., Jones, A. E., Stansfeld, A. G., Richards, M. A., Dhaliwal, H. S. *et al.* Follicular lymphoma: prognostic factors for response and survival. *Journal of Clinical Oncology* 1986; **4** 1470-1480.
30. Al-Tourah, A. J., Gill, K. K., Chhanabhai, M., Hoskins, P. J., Klasa, R. J., Savage, K. J. *et al.* Population-based analysis of incidence and outcome of transformed non-Hodgkin's lymphoma. *Journal of Clinical Oncology* 2008; **26** 5165-5169.
31. Olin, R. L., Kanetsky, P. A., Ten Have, T. R., Nasta, S. D., Schuster, S. J., and Andreadis, C. Determinants of the optimal first-line therapy for follicular lymphoma: a decision analysis. *American Journal of Hematology* 2010; **85** 255-260.
32. Coiffier, B. First-line treatment of follicular lymphoma in the era of monoclonal antibodies. *Clinical Advances in Hematology and Oncology* 2005; **3** 484-91.
33. Carbone, P P, Meier, H S, Musshoff, K, Smithers, D W, and Tubiana, M. Report of the Committee on Hodgkin's Disease Staging Classification. *Cancer Research* 1971; **31** 1861-
34. Hiddemann, W., Buske, C., Dreyling, M., Weigert, O., Lenz, G., and Unterhalt, M. Current management of follicular lymphomas. *British Journal of Haematology*. 2007; **136** 191-202.
35. Knight, C, Hind, D, Brewer, N, and Abbott, V. Rituximab (MabThera®) for aggressive non-Hodgkin's lymphoma: systematic review and economic evaluation. *Health Technology Assessment* 2004; **8**
36. Morton, L. M., Turner, J. J., Cerhan, J. R., Linet, M. S., Treseler, P. A., Clarke, C. A *et al.* Proposed classification of lymphoid neoplasms for epidemiologic research from the Pathology Working Group of the

International Lymphoma Epidemiology Consortium (InterLymph). *Blood* 2007; **110** 695-708.

37. National Cancer Institute SEER Training. URL: <http://training.seer.cancer.gov/lymphoma/abstract-code-stage/morphology/formulation.html> Accessed 2011.
38. Lennert, K., Feller, A. C., Diebold, J, Paulli, A, and Le Torneau, A. Histopathology of Non-Hodgkin's Lymphomas (Based on the Updated Kiel Classification). Berlin: Springer; 2002
39. Longo, D. L. What's the deal with follicular lymphomas? *Journal of Clinical Oncology* 1993; **11** 202-208.
40. Ghielmini, M., Rufibach, K., Salles, G., Leoncini-Francini, L., Leger-Falandry, C., Cogliatti, S. *et al.* Single agent rituximab in patients with follicular or mantle cell lymphoma: clinical and biological factors that are predictive of response and event-free survival as well as the effect of rituximab on the immune system: a study of the Swiss Group for Clinical Cancer Research (SAKK). *Annals of Oncology*. 2005; **16** 1675-1682.
41. Luminari, S. and Federico, M. Prognosis of follicular lymphomas. *Hematological Oncology* 2006; **24** 64-72.
42. Oken, M. M., Creech, R. H., Tormey, D. C., Horton, J., Davis, T. E., McFadden, E. T., and Carbone, P. P. Toxicity and response criteria of the Eastern Cooperative Oncology Group. *American Journal of Clinical Oncology* 1982; **5** 649-655.
43. Decaudin, D., Lepage, E., Brousse, N., Brice, P., Harousseau, J. L., Belhadj, K. *et al.* Low-grade stage III-IV follicular lymphoma: multivariate analysis of prognostic factors in 484 patients--a study of the groupe d'Etude des lymphomes de l'Adulte. *Journal of Clinical Oncology* 1999; **17** 2499-2505.
44. Soubeyran, P., Eghbali, H, Bonchion, F, Trojanic, M, Richauid, P, and Hoernia, B. Low-grade follicular lymphomas: Analysis of prognosis in a series of 281 patients. *European Journal of Cancer* 1991; **27** 1606-1613.

45. Morrison, V. A. Non-Hodgkin's lymphoma in the elderly. Part 1: Overview and treatment of follicular lymphoma. *Oncology (Williston Park)* 2007; **21** 1104-1110.
46. Warnke, R. A., Kim, H., Fuks, Z., and Dorfman, R. F. The coexistence of nodular and diffuse patterns in nodular non-Hodgkin's lymphomas: significance and clinicopathologic correlation. *Cancer* 1977; **40** 1229-1233.
47. Hicks, E E, Rappaport, H, and Winter, W J. Follicular lymphoma; a re-evaluation of its position in the scheme of malignant lymphoma, based on a survey of 253 cases. *Cancer* 1956; **9** 792-821.
48. Ezdinli, E. Z., Costello, W. G., Kucuk, O., and Berard, C. W. Effect of the degree of nodularity on the survival of patients with nodular lymphomas. *Journal of Clinical Oncology* 1987; **5** 413-418.
49. Hu, E., Weiss, L. M., Hoppe, R. T., and Horning, S. J. Follicular and diffuse mixed small-cleaved and large-cell lymphoma--a clinicopathologic study. *Journal of Clinical Oncology* 1985; **3** 1183-1187.
50. Farinha, P., Masoudi, H., Skinnider, B. F., Shumansky, K., Spinelli, J. J., Gill, K. *et al.* Analysis of multiple biomarkers shows that lymphoma-associated macrophage (LAM) content is an independent predictor of survival in follicular lymphoma (FL). *Blood* 2005; **106** 2169-2174.
51. Medeiros, L. J., Picker, L. J., Gelb, A. B., Strickler, J. G., Brain, S. W., Weiss, L. M. *et al.* Numbers of host "helper" T cells and proliferating cells predict survival in diffuse small-cell lymphomas. *Journal of Clinical Oncology* 1989; **7** 1009-1017.
52. Strickler, J. G., Copenhaver, C. M., Rojas, V. A., Horning, S. J., and Warnke, R. A. Comparison of "host cell infiltrates" in patients with follicular lymphoma with and without spontaneous regression. *American Journal of Clinical Pathology* 1988; **90** 257-261.
53. Federico, M., Vitolo, U., Zinzani, P. L., Chisesi, T., Clo, V., Bellesi, G., *et al.* Prognosis of follicular lymphoma: a predictive model based on a retrospective

- analysis of 987 cases. Intergruppo Italiano Linfomi. *Blood* 1-2-2000; **95** 783-789.
54. Bastion, Y., Berger, F., Bryon, P. A., Felman, P., Ffrench, M., and Coiffier, B. Follicular lymphomas: assessment of prognostic factors in 127 patients followed for 10 years. *Annals of Oncology* 1991; **2 Suppl 2** 123-129.
 55. Romaguera, J. E., McLaughlin, P., North, L., Dixon, D., Silvermintz, K. B., Garnsey, L. A. *et al.* Multivariate analysis of prognostic factors in stage IV follicular low-grade lymphoma: a risk model. *Journal of Clinical Oncology* 1991; **9** 762-769.
 56. Lopez-Guillermo, A., Montserrat, E., Bosch, F, Terol, M J, Campo, E, and Rozman, C. Applicability of the International Index for Aggressive Lymphomas to patients with low-grade lymphoma. *Journal of Clinical Oncology* 1994; **12** 1343-1348.
 57. Solal-Celigny, P., Cahu, X., and Cartron, G. Follicular lymphoma prognostic factors in the modern era: what is clinically meaningful? *International Journal of Hematology*. 2010; **92** 246-254.
 58. Federico, M., Bellei, M., Marcheselli, L., Luminari, S., Lopez-Guillermo, A., Vitolo, U. *et al.* Follicular lymphoma international prognostic index 2: a new prognostic index for follicular lymphoma developed by the international follicular lymphoma prognostic factor project. *Journal of Clinical Oncology* 2009; **27** 4555-4562.
 59. Morschhauser, F., Dreyling, M., Rohatiner, A., Hagemester, F., and Bischof, Delaloye A. Rationale for consolidation to improve progression-free survival in patients with non-Hodgkin's lymphoma: a review of the evidence. *Oncologist* 2009; **14 Suppl 2** 17-29.
 60. Wake, B., Hyde, C., Bryan, S., Barton, P., Song, F., Fry-Smith, A., and Davenport, C. Rituximab as third-line treatment for refractory or recurrent Stage III or IV follicular non-Hodgkin's lymphoma: a systematic review and economic evaluation. *Health Technology Assessment* 2002; **6** 1-85.

61. Roche. MabThera (R) (rituximab) for the first-line treatment of follicular non-Hodgkin's lymphoma: submission to the National Institute for Health and Clinical Excellence (NICE). 2010;
62. Horning, S. J. and Rosenberg, S. A. The natural history of initially untreated low-grade non-Hodgkin's lymphomas. *New England Journal of Medicine*. 1984; **311** 1471-1475.
63. Martinsson, U., Glimelius, B., Hagberg, H., and Sundstrom, C. Primarily asymptomatic low-grade non-Hodgkin lymphomas: prediction of symptom-free survival and total survival. *European Journal of Haematology*. 1989; **43** 332-338.
64. Brice, P., Bastion, Y., Lepage, E., Brousse, N., Haioun, C., Moreau, P. *et al.* Comparison in low-tumor-burden follicular lymphomas between an initial no-treatment policy, prednimustine, or interferon alfa: a randomized study from the Groupe d'Etude des Lymphomes Folliculaires. Groupe d'Etude des Lymphomes de l'Adulte. *Journal of Clinical Oncology* 1997; **15** 1110-1117.
65. Ardeschna, K. M., Smith, P., Norton, A., Hancock, B. W., Hoskin, P. J., MacLennan, K. A. *et al.* Long-term effect of a watch and wait policy versus immediate systemic treatment for asymptomatic advanced-stage non-Hodgkin lymphoma: a randomised controlled trial. *Lancet* 2003; **362** 516-522.
66. Young, R. C., Longo, D. L., Glatstein, E., Ihde, D. C., Jaffe, E. S., and DeVita, V. T., Jr. The treatment of indolent lymphomas: watchful waiting v aggressive combined modality treatment. *Seminars in Hematology*. 1988; **25** 11-16.
67. Heinzlmann, F., Ottinger, H., Engelhard, M., Soekler, M., Bamberg, M., and Weinmann, M. Advanced-stage III/IV follicular lymphoma: treatment strategies for individual patients. *Strahlentherapie und Onkologie* 2010; **186** 247-254.
68. Hiddemann, W. Rituximab maintenance therapy in follicular lymphoma comes of age. *Leukemia Research* 2006; **30 Suppl 1** S1-S2.

69. Salles, G., Seymour, J F, Feugier, P, Offner, F, Lopez-Guillermo, A., Bouabdallah, R, and Pedersen, L M Rituximab maintenance for 2 years in patients with untreated high tumor burden follicular lymphoma after response to immunochemotherapy (Abstract 8004). *ASCO Annual Meeting* 2010;
70. National Institute for Health and Clinical Excellence (NICE). Rituximab for the treatment of relapsed or refractory stage III or IV follicular non-Hodgkin's lymphoma (review of technology appraisal guidance no. 137). London: NICE; 2008
71. van Oers, M. H., Van, Glabbeke M., Giurgea, L., Klasa, R., Marcus, R. E., Wolf, M. *et al.* Rituximab maintenance treatment of relapsed/resistant follicular non-Hodgkin's lymphoma: long-term outcome of the EORTC 20981 phase III randomized intergroup study. *Journal of Clinical Oncology* 2010; **28** 2853-2858.
72. van Oers, M. H., Klasa, R., Marcus, R., Wolf, H., Kimby, E., Gascoyne, R. D., *et al.* Rituximab maintenance improves clinical outcome of relapsed/resistant follicular non-Hodgkin lymphoma in patients both with and without rituximab during induction: results of a prospective randomized phase 3 intergroup trial. *Blood* 2006; **108** 3295-33014.
73. British Committee for Standards in Haematology Best Practice in Lymphoma Diagnosis and Reporting. 2010. URL: http://www.bcshguidelines.com/documents/Lymphoma_diagnosis_bcsh_042010.pdf Accessed 2011.
74. British Committee for Standards in Haematology Best Practice in Lymphoma Diagnosis and Reporting: Specific disease appendix. 2010. URL: http://www.bcshguidelines.com/documents/Lymphoma_disease_app_bcsh_042010.pdf Accessed 2011.
75. Rummel, M, Niederle, N, Maschmeyer, G, Banat, A, von Gruenhagen, U, Losem, C, *et al.* Bendamustine Plus Rituximab Is Superior in Respect of Progression Free Survival and CR Rate When Compared to CHOP Plus Rituximab as First-Line Treatment of Patients with Advanced Follicular, Indolent, and Mantle Cell Lymphomas: Final Results of a Randomized Phase

- III Study of the StiL (Study Group Indolent Lymphomas, Germany). ASH Annual Meeting, 2009. 51st Annual Meeting, New Orleans, USA.
76. Multicentric Study, Three Randomized Arms (R-CVP vs R-CHOP vs R-FM),for Patients With Stage II-IV Follicular Lymphoma. URL: <http://clinicaltrials.gov/ct2/show/NCT00774826> Accessed 2011.
77. First-Line R-CVP vs R-CHOP Induction Immunochemotherapy for Indolent Lymphoma and R Maintenance. (PLRG4). URL: <http://clinicaltrials.gov/ct2/show/NCT00801281> Accessed 2011.
78. Alkylator Combination In Follicular lymphoma Immuno-Chemotherapy for Older patients: a phase III comparison of first-line R-CVP versus R-FC (previous acronym: RiCH FLO). URL: <http://public.ukcrn.org.uk/search/StudyDetail.aspx?StudyID=6898> Accessed 2011.
79. Siddhartha, G. and Vijay, P. R-CHOP versus R-CVP in the treatment of follicular lymphoma: a meta-analysis and critical appraisal of current literature. *Journal of Hematology and Oncology*. 2009; **2** 14-
80. National Institute for Health and Clinical Excellence (NICE) Rituximab for the treatment of follicular lymphoma: NICE technology appraisal guidance no. 110. London: NICE; 2006.
81. Anderson, K. C., Bates, M. P., Slaughenhaupt, B. L., Pinkus, G. S., Schlossman, S. F., and Nadler, L. M. Expression of human B cell-associated antigens on leukemias and lymphomas: a model of human B cell differentiation. *Blood* 1984; **63** 1424-1433.
82. European Medicines Agency (EMA). MabThera: European Public Assessment Report (EPAR)-Product information: Annex I - Summary of product Characteristics. URL: http://www.ema.europa.eu/docs/en_GB/document_library/EPAR_-_Product_Information/human/000165/WC500025821.pdf. Accessed 2011.

83. EMEA MabThera: EPAR- Product information. URL:
http://www.ema.europa.eu/docs/en_GB/document_library/EPAR_-_Product_Information/human/000165/WC500025821.pdf. Accessed 2011.
84. British Medical Association, Royal Pharmaceutical Society of Great Britain
 British National Formulary No. 61. 2011. URL: <http://bnf.org/bnf/index.htm>
 Accessed 2011.
85. British Committee for Standards in Haematology. Follicular lymphoma. 2011;
86. Moher, D, Liberati, A, Tetzlaff, J, Altman, D G, and The PRISMA Group.
 Preferred Reporting Items for Systematic Reviews and Meta-Analyses The
 PRISMA Statement. *Journal of Clinical Epidemiology* 2009; **62** 1006-1012.
87. Cheson, B D, Horning, S. J., Coiffier, B., Shipp, M A, Fisher, R. I., Connors,
 J. M. *et al.* Report of an international workshop to standardize response
 criteria for non-Hodgkin's lymphomas. NCI Sponsored International Working
 Group. *Journal of Clinical Oncology*. 1999; **17** 1244-
88. Centre for Reviews and Dissemination Systematic reviews: CRD's guidance
 for undertaking reviews in health care. York: Centre for Reviews &
 Dissemination; 2009.
89. Review Manager (RevMan) [Computer program].Version 5.0. 2008;
90. Buske, C., Hoster, E., Dreyling, M., Forstpointner, R., Kneba, M., Schmitz,
 N., Schmits, R. *et al.* Rituximab in Combination with CHOP in Patients with
 Follicular Lymphoma: Analysis of Treatment Outcome of 552 Patients
 Treated in a Randomized Trial of the German Low Grade Lymphoma Study
 Group (GLSG) after a Follow up of 58 Months [Abstract No. 2599]. *Blood*
 2008; **112**
91. Hiddemann, W., Kneba, M., Dreyling, M., Schmitz, N., Lengfelder, E.,
 Schmits, R. *et al.* Frontline therapy with rituximab added to the combination
 of cyclophosphamide, doxorubicin, vincristine, and prednisone (CHOP)
 significantly improves the outcome for patients with advanced-stage follicular
 lymphoma compared with therapy with CHOP alone: results of a prospective

- randomized study of the German Low-Grade Lymphoma Study Group. *Blood* 2005; **106** 3725-3732.
92. Herold, M., Haas, A., Srock, S., Naser, S., Al-Ali, K. H., Neubauer, A., Dolken, G. *et al.* Rituximab added to first-line mitoxantrone, chlorambucil, and prednisolone chemotherapy followed by interferon maintenance prolongs survival in patients with advanced follicular lymphoma: an East German Study Group Hematology and Oncology Study. *Journal of Clinical Oncology* 2007; **25** 1986-1992.
93. Salles, G., Mounier, N., de, Guibert S., Morschhauser, F., Doyen, C., Rossi, J. F. *et al.* Rituximab combined with chemotherapy and interferon in follicular lymphoma patients: results of the GELA-GOELAMS FL2000 study. *Blood* 2008; **112** 4824-4831.
94. Marcus, R., Imrie, K., Solal-Celigny, P., Catalano, J. V., Dmoszynska, A., Raposo, J. C. *et al.* Phase III study of R-CVP compared with cyclophosphamide, vincristine, and prednisone alone in patients with previously untreated advanced follicular lymphoma. *Journal of Clinical Oncology* 2008; **26** 4579-4586.
95. Marcus, R., Imrie, K., Belch, A., Cunningham, D., Flores, E., Catalano, J., *et al.* CVP chemotherapy plus rituximab compared with CVP as first-line treatment for advanced follicular lymphoma. *Blood* 2005; **105** 1417-1423.
96. National Institute for Health and Clinical Excellence (NICE). *Guide to the methods of technology appraisal*. London: NICE; 2008.
97. A Study of MabThera (Rituximab) in Elderly Patients With Untreated Follicular Non-Hodgkin's Lymphoma (NHL). URL: <http://clinicaltrials.gov/ct2/show/NCT01144364>. Accessed 2011.
98. BNLI RCT of MCD vs FMD in follicular NHL. URL: <http://public.ukcrn.org.uk/search/StudyDetail.aspx?StudyID=908> Accessed 2011.

99. National Cancer Institute. National Cancer Institute Common Toxicity Criteria (CTC). URL:
http://ctep.cancer.gov/protocolDevelopment/electronic_applications/ctc.htm.
[Accessed 2011.](#)
100. World Health Organisation. *WHO Handbook for reporting results of Cancer Treatment*. WHO offset publication No. 48 Neoplasma. 1980; 20: 37-46. 1980;
101. Solal-Celigny, P, Imrie, K, Belch, A, Robinson, K, Cunningham, D, Rueda, A, *et al*. Mabthera (Rituximab) plus CVP chemotherapy for first-line treatment of stage III/IV follicular non-Hodgkin's lymphoma (NHL): Confirmed efficacy with longer follow-up. *Blood* 2005; **106** 106A-
102. Parmar, M. K., Torri, V., and Stewart, L. Extracting summary statistics to perform meta-analyses of the published literature for survival endpoints. *Statistics in Medicine* 1998; **17** 2815-2834.
103. Marcus, R., Imrie, K., Solal-Celigny, P., Catalano, J. V., Dmoszynska, A., Raposo, J. C. *et al*. Phase III study of R-CVP compared with cyclophosphamide, vincristine, and prednisone alone in patients with previously untreated advanced follicular lymphoma. *Journal of Clinical Oncology* 2008; **26** 4579-4586.
104. European Medicines Agency (EMA) Assessment report for MabThera: International non-proprietary name/Common name: rituximab Procedure No.EMA/H/C/000165/II/0053. 2008;
105. Buske, C. The Follicular Lymphoma International Prognostic Index (FLIPI) separates high-risk from intermediate- or low-risk patients with advanced-stage follicular lymphoma treated front-line with rituximab and the combination of cyclophosphamide, doxorubicin, vincristine, and prednisone (R-CHOP) with respect to treatment outcome. *Blood* 2006; **108** 1504-1508.
106. Higgins, J P T, Green, S. Cochrane Handbook for Systematic Reviews of Interventions Version 5.0.2 [updated September 2009]. The Cochrane Collaboration, 2009. Available from www.cochrane-handbook.org. 2009;

107. Brundage, MD, Pater, JL, and Zee, B .Assessing the reliability of two toxicity scales: Implication for interpreting toxicity data. *Journal of the National Cancer Institute* 1993; **85** 1148-
108. Moher, D, Schulz, K F, Altman, D G, and for the Consort Group. The CONSORT statement: revised recommendations for improving the quality of reports of parallel group randomized trials. *Annals of Internal Medicine* 2001; **134** 657-662.
109. Buske, C., Kneba, M., Lengfelder, E., Pfreundschuh, M., Ludwig, W. D., Graeven, U. *et al.* Front - Line Combined Immuno-Chemotherapy (R-CHOP) Significantly Improves the Time to Treatment Failure and Overall Survival in Elderly Patients with Advanced Stage Follicular Lymphoma - Results of a Prospective Randomized Trial of the German Low Grade Lymphoma Study Group (GLSG). *Blood* 2006; **108** 146-147.
110. Drummond, M F and Jefferson, T O. Guidelines for authors and peer reviewers of economic submissions to the BMJ. *British Medical Journal* 1996; **313** 275-283.
111. Eddy, D M. The role of mathematical modeling in Assessing medical technology. *Technology Assessment* 1985;154-
112. Ray, J. A., Carr, E., Lewis, G., and Marcus, R. An evaluation of the cost-effectiveness of rituximab in combination with chemotherapy for the first-line treatment of follicular non-Hodgkin's lymphoma in the UK. *Value in Health* 2010; **13** 346-357.
113. Dundar, Y., Hounsome, J, McLeod, C., Bagust, A., Boland, A., Davis, H., Walley, T., and Dickson, R. Rituximab for the first line treatment of stage III-IV follicular non-Hodgkin's lymphoma. 2006;
114. Dundar, Y., Bagust, A., Hounsome, J., McLeod, C., Boland, A., Davis, H., Walley, T., and Dickson, R. Rituximab for the first-line treatment of stage III/IV follicular non-Hodgkin's lymphoma. *Health Technol.Assess.* 2009; **13 Suppl 1** 23-28.

115. Gomez, J. R. Pharmacoeconomic analysis of adding rituximab to chemotherapy as first line treatment for patients with advanced follicular lymphoma. *Pharmacoeconomics - Spanish Research Articles* 2010; **7** 55-67.
116. Hornberger, J., Reyes, C., Lubeck, D. and Valente, N. Economic evaluation of rituximab plus cyclophosphamide, vincristine and prednisolone for advanced follicular lymphoma. *Leukemia & Lymphoma* 2008; **49** 227-236.
117. Scottish and Newcastle Lymphoma Group SNLG@ed.ac.uk: Database analysis (Roche data on file). 2004;
118. Swenson, W. T., Wooldridge, J. E., Lynch, C. F., Forman-Hoffman, V. L., Chrischilles, E., and Link, B. K. Improved survival of follicular lymphoma patients in the United States. *Journal of Clinical Oncology* 2005; **23** 5019-5026.
119. Wild, D, Pettengell, R., and Lewis, G. Utility elicitation in patients with follicular lymphoma. ISPOR 9th Annual European Congress. Copenhagen, Denmark; 28-31 October, 2006.
120. Wild, D, Pettengell, R., and Lewis, G. Utility elicitation in patients with follicular lymphoma. Unpublished report by Oxford Outcomes prepared for Roche UK. 2005;
121. Tolley, K, Morgan, G, Cartwright, R, and Williams, R Economic aspects of non-Hodgkin's lymphoma. 1998;
122. Guadagnolo, B. A., Punglia, R. S., Kuntz, K. M., Mauch, P. M., and Ng, A. K. Cost-effectiveness analysis of computerized tomography in the routine follow-up of patients after primary treatment for Hodgkin's disease. *Journal of Clinical Oncology* 2006; **24** 4116-4122.
123. Seviles CfMaM ASP Drug Pricing Files. 2006;
124. Hoover, D, Crystal, S, Kumar, R, Sambamoorthi, U, and Cantor, J. Medical expenditures during the last year of life: findings from the 1992-1996 Medicare current beneficiary survey. *Health Services Research* 2002; **37** 1625-1642.

125. Roche. Rituximab for the first line maintenance treatment of follicular non-hodgkin's lymphoma: Roche Submission to the National Institute for Health and Clinical Excellence. 2010;
126. Guidance on Cancer Services Improving Supportive and Palliative Care for Adults with Cancer. Economic Review . London: NICE; 2004;
127. Greenhalgh, J, Bagust, A., Boland, A., Blundell, M, Oyee, J, Dundar, Y., and Hockenhull, J. Rituximab for the first-line maintenance treatment of follicular non-Hodgkin's lymphoma: A Single Technology Appraisal. 2010;
128. National Institute for Health and Clinical Excellence (NICE). Rituximab for the maintenance treatment of follicular non-Hodgkin's lymphoma following response to first-line chemotherapy. URL: <http://guidance.nice.org.uk/TA/Wave19/59> Accessed 2011
129. Johnston, A, Bouafia-Sauvy, F, Broussais-Guillaumot, F, Michallet, AS, Traulle, C, Salles, G, and Coiffier, B. Re-treatment with rituximab in 178 patients with relapsed and refractory B-cell lymphomas: a single institution case control study. *Leukemia and Lymphoma* 2010; **51** 399-405.
130. Coiffier, B., Bouafia-Sauvy, F, Thieblemont, C, Hequet, O, Arnaud, P, Dumontet, C, and Espinouse, D Rituximab re-treatment in B-cell lymphoma patients : efficacy and toxicity in 59 patients treated in one center. *Blood* 2002; **100** 1390 [abstract]-
131. Borgerding, A., Hasenkamp, J., Glass, B., Wulf, G., and Trumper, L. Rituximab retherapy in patients with relapsed aggressive B cell and mantle cell lymphoma. *Annals of Hematology* 2010; **89** 283-289.
132. Martin, A., Conde, E., Arnan, M., Canales, M. A., Deben, G., Sancho, J. M. *et al.* R-ESHAP as salvage therapy for patients with relapsed or refractory diffuse large B-cell lymphoma: the influence of prior exposure to rituximab on outcome. A GEL/TAMO study. *Haematologica* 2008; **93** 1829-1836.
133. Weide, R., Hess, G., Koppler, H., Heymanns, J., Thomalla, J., Aldaoud, A., *et al.* High anti-lymphoma activity of bendamustine/mitoxantrone/rituximab in

- rituximab pretreated relapsed or refractory indolent lymphomas and mantle cell lymphomas. A multicenter phase II study of the German Low Grade Lymphoma Study Group (GLSG). *Leuk.Lymphoma* 2007; **48** 1299-1306.
134. National Institute for Health and Clinical Excellence (NICE) Rituximab for the first-line treatment of stage III-IV follicular lymphoma (Review of TA 110): Final scope. 2010. URL:
<http://www.nice.org.uk/nicemedia/live/12982/50703/50703.pdf> Accessed 2011.
135. Sebban, C., Brice, P., Delarue, R, Haioun, C., Souleau, B, Mounier, N., and Brousse, N. Impact of rituximab and / or high-dose therapy with autotransplant at time of relapse in patients with follicular lymphoma: a GELA study. *Journal of Clinical Oncology* 2008; **26** 3614-3620.
136. Office for National Statistics Interim Life Tables, England & Wales, 1980-82 to 2007-09. URL:
<http://www.statistics.gov.uk/StatBase/Product.asp?vlnk=14459> Accessed 2011.
137. Collet, D. Modelling survival data in medical research. 2003; **2nd edition**. Boca Raton, FL: Chapman & Hall/CRC
138. Nickenig, C., Dreyling, M., Hoster, E., Pfreundschuh, M., Trumper, L., Reiser, M. *et al*. Combined cyclophosphamide, vincristine, doxorubicin, and prednisone (CHOP) improves response rates but not survival and has lower hematologic toxicity compared with combined mitoxantrone, chlorambucil, and prednisone (MCP) in follicular and mantle cell lymphomas: results of a prospective randomized trial of the German Low-Grade Lymphoma Study Group. *Cancer* 2006; **107** 1014-1022.
139. Montserrat, E., Garcia-Conde, J., Vinolas, N., Lopez-Guillermo, A., Hernandez-Nieto, L., Zubizarreta, A. *et al*. CHOP vs. ProMACE-CytaBOM in the treatment of aggressive non-Hodgkin's lymphomas: long-term results of a multicenter randomized trial.(PETHEMA: Spanish Cooperative Group for the Study of Hematological Malignancies Treatment, Spanish Society of Hematology). *European Journal of Haematology*. 1996; **57** 377-383.

140. Forstpointer, R., Unterhalt, M., Dreyling, M., Bock, HP, Repp, R, Wandt, H, and Pott, C. Maintenance therapy with rituximab leads to a significant prolongation of response duration after salvage therapy with a combination of rituximab, fludarabine, cyclophosphamide, and mitoxantrone (R-FCM) in patients with recurring and refractory follicular and mantle cell lymphomas: results of a prospective randomized study of the German Low Grade Lymphoma Study Group (GLSG). *Blood* 2006; **108** 4003-4008.
141. UK Department of Health National Health Service Reference Costs (2009/10). URL: http://www.dh.gov.uk/en/Publicationsandstatistics/Publications/PublicationsPolicyAndGuidance/DH_123459 Accessed 2011.
142. Surrey, West Sussex and Hampshire Cancer Network NHS Clinical policies & protocols: 2nd line/salvage regimens for Lymphoma: ESHAP. URL: http://www.swshcn.nhs.uk/healthcare-professionals/clinical-policies-and-protocols/haematology_protocols/2nd-line-salvage-regimens-for-lymphoma/ESHAP.pdf Accessed 2011
143. London Specialised Commissioning Group Adult BMT Costing and Pricing Model Workshop. 2009. URL: www.kentmedwaycancernetwork.nhs.uk/EasySiteWeb/getresource.axd?AssetID=93605&type=full&servicetype=Attachment Accessed 2011.
144. Guest, J. F., Ruiz, F. J., Greener, M. J., and Trotman, I. F. Palliative care treatment patterns and associated costs of healthcare resource use for specific advanced cancer patients in the UK. *European Journal of Cancer Care (Engl.)* 2006; **15** 65-73.
145. Friedlich, J. D., Cheung, M. C., Imrie, K. R., Hales, B., Mittmann, N., and Buckstein, R. Discrimination of health states in follicular lymphoma with utilities derived from the EuroQOL EQ5D instrument. *Blood* 2006; **108** 3329-
146. Pettengell, R., Donatti, C, Hoskin, P. J., Poynton, C, Kettle, PJ, Hancock, B. W., and Johnson, S. The impact of follicular lymphoma on health-related quality of life. *Annals of Oncology* 2008; **19** 570-576.

147. Gao, G., Liang, X., Jiang, J., Zhou, X., Huang, R., Chu, Z., and Zhan, Q. A systematic review and meta-analysis of immunochemotherapy with rituximab for B-cell non-Hodgkin's lymphoma. *Acta Oncologica* 2010; **49** 3-12.
148. Schulz, H, Bohlius, J, Skoetz, N, Trelle, S, Kober, T, Reiser, M, Dreyling, M., and Herold, M. Chemotherapy plus Rituximab versus chemotherapy alone for B-cell non-Hodgkin's lymphoma. *Cochrane Database of Systematic Reviews* 2007, Issue 4. Art.No.: CD003805. DOI: 10.1002/14651858.CD003805.pub2. 2007;
149. Schulz, H, Bohlius, J, Trelle, S, Skoetz, N, Reiser, M, Kober, T, Schwarzer, G, and Herold, M. Immunochemotherapy With Rituximab and Overall Survival in Patients With Indolent or Mantle Cell Lymphoma. *Journal of the National Cancer Institute* 2007; **99** 706-714.
150. Office for National Statistics Mid Year Population Estimates 2008: 13/05/10. URL: <http://www.statistics.gov.uk/statbase/product.asp?vlnk=15106>. Accessed 2011.
151. Cancer Research UK. Performance status. URL: <http://www.cancerhelp.org.uk/about-cancer/cancer-questions/performance-status> Accessed 2011.