

Single Technology Appraisal

Lenalidomide for the maintenance treatment of multiple myeloma after autologous stem cell transplantation [ID475]

Committee Papers

NATIONAL INSTITUTE FOR HEALTH AND CARE EXCELLENCE

SINGLE TECHNOLOGY APPRAISAL

Lenalidomide for the maintenance treatment of multiple myeloma after autologous stem cell transplantation [ID475]

Contents:

The following documents are made available to consultees and commentators:

The [final scope and final stakeholder list](#) are available on the NICE website.

1. [Company submission from BMS/Celgene](#)
2. [Clarification questions and company responses](#)
3. [Patient group, professional group and NHS organisation submission](#)
from:
 - a. [Myeloma UK](#)
 - b. [Royal College of Pathologists, British Society of Haematology and the UK Myeloma Forum](#)
4. [Expert personal perspectives](#) from:
 - a. [Mr Stephen Billcliffe – patient expert, nominated by Myeloma UK](#)
Dr Pratt – clinical expert, nominated by the Royal College of Pathologists
Dr Pratt supports the statement from the Royal College of Pathologists, British Society for Haematology and the UK Myeloma Forum and will not be submitting an individual statement
Dr Ramasamy – clinical expert, nominated by the Royal College of Pathologists
Dr Ramasamy supports the statement from the Royal College of Pathologists, British Society for Haematology and the UK Myeloma Forum and will not be submitting an individual statement
Ms Sheila Mckinlay – patient expert, nominated by Myeloma UK
Ms McKinlay supports the statement from Myeloma UK and will not be submitting an individual statement
5. [Evidence Review Group report prepared by Peninsula Technology Assessment Group \[PenTAG\]](#)
6. [Evidence Review Group – factual accuracy check](#)
7. [Technical Report](#)
8. [Technical engagement response from BMS/Celgene](#)

9. **Technical engagement response from consultees and commentators:**
 - a. Myeloma UK
 - b. Royal College of Pathologists (RCP) and British Society of Haematology (BSH)

10. **Evidence Review Group critique of company response to technical engagement prepared by PenTAG**

Any information supplied to NICE which has been marked as confidential, has been redacted. All personal information has also been redacted.

NATIONAL INSTITUTE FOR HEALTH AND CARE EXCELLENCE

Single technology appraisal

Lenalidomide for the maintenance treatment of multiple myeloma after autologous stem cell transplantation [ID475]

Document B

Company evidence submission

February 2020

File name	Version	Contains confidential information	Date
Revlimid_MM maint_NICE_Section B [ID475]	1.0	Yes	18 February 2020

Contents

Abbreviations	6
B.1 Decision problem, description of the technology and clinical care pathway	9
B.2 Clinical effectiveness	28
B.3 Cost effectiveness	60
References	110

Tables

Table 1 The decision problem	10
Table 2 Technology being appraised	12
Table 3 Multiple myeloma incidence and mortality in England and Wales	15
Table 4 First stem cell transplants given to patients with multiple myeloma in the United Kingdom and Republic of Ireland (2017–2018).....	20
Table 5. Comparison of CALGB 100104, IFM 2005-02, GIMEMA and Myeloma XI. 28	
Table 6. Summary of clinical effectiveness evidence (Myeloma XI).....	31
Table 7 Myeloma XI: cohort relevant to decision problem.....	32
Table 8. Key eligibility criteria for maintenance therapy in Myeloma XI.....	36
Table 9. Study maintenance drug, dose and duration	37
Table 10. Dose reduction recommendations.....	37
Table 11. Outcome measures available from Myeloma XI and their inclusion into the economic model	39
Table 12. Summary of Myeloma XI methodology.....	40
Table 13. [REDACTED]	42
Table 14. Summary of statistical analyses used in Myeloma XI	45
Table 15. [REDACTED]	47
Table 16. [REDACTED]	51
Table 17. Comparative summary of key efficacy and safety outcomes in CALGB 100104, GIMEMA, IFM 2005-02 and Myeloma XI.....	57
Table 18. End-of-life criteria	59
Table 19. Summary of results of identified published cost-effectiveness analyses ..	61
Table 20. Features of the economic analysis	66
Table 21: Criteria considered for determining the most suitable parametric survival models.....	68
Table 22: Parametric survival curves for PFS – goodness of fit statistics	71
Table 23. Parametric survival curves for OS – goodness of fit statistics	76
Table 24. Parametric survival curves for TOT – goodness of fit statistics	81
Table 25 [REDACTED]	85
Table 26. Summary of utility values for cost-effectiveness analysis	86
Table 27. Summary of utility values for scenario analysis	86
Table 28. Summary of utility values for adverse events	87
Table 29. Lenalidomide as maintenance acquisition costs.....	88
Table 30. Adverse event costs	89
Table 31. [REDACTED]	91
Table 32. Subsequent therapy costs	93
Table 33. Subsequent treatment use	95
Table 34. Summary of variables applied in the economic model	97
Table 35: Model assumptions	98
Table 36. Base-case results	99
Table 37. Probabilistic incremental cost-effectiveness analysis results (with PAS) 100	
Table 38. Scenario analysis results.....	102
Table 39. Comparison of model outputs and Myeloma XI.....	105
Table 40. Validation of cost-effectiveness analysis	105

Figures

Figure 1. Characteristic pattern of remission and relapse following conventional chemotherapy in multiple myeloma	16
Figure 2 Changes in patient emotional and physical well-being over time	18
Figure 3. Proposed place of lenalidomide maintenance therapy in the NHS England chemotherapy treatment algorithm.....	25
Figure 4. An overview of the maintenance phase of the Myeloma XI trial (protocol Version 5.0 onwards)	35
Figure 5. Summary of participants included in the Myeloma XI analysis.....	46
Figure 6. [REDACTED]	49
Figure 7. [REDACTED]	50
Figure 8. Determining state membership	65
Figure 9 Log-cumulative hazard plot (A) and quantile-quantile plot (B) for PFS.....	69
Figure 10 Log-cumulative hazard plot (A) and quantile-quantile plot (B) for OS	70
Figure 11. [REDACTED]	72
Figure 12 [REDACTED]	73
Figure 13 [REDACTED]	74
Figure 14 [REDACTED]	75
Figure 15 [REDACTED]	76
Figure 16 [REDACTED]	77
Figure 17. [REDACTED]	78
Figure 18 [REDACTED]	79
Figure 19. [REDACTED]	80
Figure 20. [REDACTED]	81
Figure 21. [REDACTED]	82
Figure 22. [REDACTED]	100
Figure 23. [REDACTED]	101
Figure 24. [REDACTED]	102

Abbreviations

AE	adverse event
AIC	Akaike information criterion
AMT	anti-myeloma therapy
ANC	absolute neutrophil count
ASCO	American Society of Clinical Oncology
ASCT	autologous stem cell transplant
ASH	American Society of Hematology
BCSH	British Committee for Standards in Haematology
BIC	Bayesian information criterion
BNF	British National Formulary
BOR	bortezomib
BSBMT	British Society of Blood and Marrow Transplantation
BSH	British Society for Haematology
CEAC	cost-effectiveness acceptability curves
CI	confidence interval
CTD	cyclophosphamide, thalidomide and dexamethasone
CTDa	attenuated cyclophosphamide, thalidomide and dexamethasone
CR	complete response
CrCl	creatinine clearance
CrI	credible interval
Dara-VD	daratumumab, bortezomib, dexamethasone
DEX	dexamethasone
DOR	duration of response
ECOG	Eastern Cooperative Oncology Group
EHA	European Haematology Association
EMA	European Medicines Agency
eMIT	electronic market information tool
EORTC	European Organisation for Research and Treatment of Cancer
EORTC QLQ-C30	EORTC Quality of Life Questionnaire – Core 30
EORTC QLQ-MY20	EORTC Quality of Life Questionnaire – Multiple Myeloma 20
EPAR	European Public Assessment Report
EQ-5D	5-dimension European Quality of Life questionnaire
ERG	evidence review group
ESMO	European Society for Medical Oncology
FDA	Food and Drugs Administration
G-CSF	granulocyte-colony stimulating factor
HMRN	Haematological Malignancy Research Network
HR	hazard ratio
HRG	healthcare resource group
HRQoL	health-related quality of life
ICER	incremental cost-effectiveness ratio
IFM	<i>Intergroupe Francophone du Myelome</i>
IMiD®	immunomodulatory drug
IMWG	International Myeloma Working Group
ITT	intent-to-treat
ISS	International Staging System

IV	intravenous
KD	carfilzomib, dexamethasone
KRD	carfilzomib, lenalidomide, dexamethasone
LDH	lactate dehydrogenase
LEN	lenalidomide
LY	life-year
MDS	myelodysplastic syndrome
MIMS	monthly index of medical specialities
MM	multiple myeloma
MPT	melphalan, prednisone and thalidomide
MRC	Medical Research Council
MRD	minimal residual disease
MSM	multi-state Markov
MTA	multiple technology appraisal
MTC	mixed treatment comparison
NCCN	National Comprehensive Cancer Network
NDMM	newly diagnosed multiple myeloma
NICE	National Institute for Health and Care Excellence
NMA	network meta-analysis
NR	not reported
ORR	overall response rate
OS	overall survival
PANO	panobinostat
PAS	patient access scheme
PD	progressive disease
PFS	progression-free survival
PFS2	progression-free survival 2
PO	<i>per os</i> (orally)
PR	partial response
PRISMA	Preferred Reporting Items for Systematic Reviews and Meta-Analyses
PSA	probabilistic sensitivity analysis
QALY	quality-adjusted life-year
QoL	quality of life
RCT	randomised controlled trial
RD	lenalidomide and dexamethasone
RDI	relative dose intensity
SAE	serious adverse event
SC	subcutaneous
SD	stable disease
SE	standard error
SLR	systematic literature review
SmPC	summary of product characteristics
SoC	standard of care
SPM	second primary malignancy
STA	single technology appraisal
TEAE	treatment-emergent adverse event
TSD	technical support document
TTP	time to progression

TTR	time to response
VAT	value added tax
VCD	bortezomib, cyclophosphamide, dexamethasone
VTD	bortezomib, thalidomide, dexamethasone
WCBP	women of childbearing potential
VGPR	very good partial response

B.1 Decision problem, description of the technology and clinical care pathway

B.1.1 *Decision problem*

The objective of this single technology appraisal (STA) is to assess the clinical and cost effectiveness of lenalidomide monotherapy according to its licence as a maintenance treatment for adult patients with newly diagnosed multiple myeloma (MM) who have undergone autologous stem cell transplantation (ASCT). This licence was granted by the European Medicines Agency (EMA) on 16 February 2017.¹

The final scope for this STA was issued on 12 December 2019, as detailed in Table 1. The submission focuses on patients with newly diagnosed MM who have undergone an ASCT. This population, which is one of several indications covered in the marketing authorisation for lenalidomide, is the focus of the current STA for the following reasons.

- Data on maintenance therapy with lenalidomide indicate a meaningful clinical benefit in patients with newly diagnosed MM who have received their first ASCT, as demonstrated in the CALGB 100104 and IFM 2005-02 trials²⁻⁴ used to support the original EMA licence variation,¹ and in the Myeloma XI trial which aligns more closely with UK clinical practice.⁵
- Other populations with MM that are covered by the marketing authorisation for lenalidomide, and which are not the focus of the current STA, are already funded in England & Wales based on National Institute for Health and Care Excellence (NICE) guidance TA586⁶, TA587,⁷ and TA171.⁸

This submission does not include indications outside of the licensed indication which is the subject of this appraisal, such as lenalidomide maintenance therapy in patients with MM who are undergoing tandem ASCT or ASCT beyond the first-line treatment setting.

Table 1 The decision problem

	Final scope issued by NICE	Decision problem addressed in the company submission	Rationale if different from the final NICE scope
Population	People with newly diagnosed multiple myeloma (MM) who have had autologous stem cell transplantation (ASCT).	Adults with newly diagnosed MM who have had ASCT	N/A
Intervention	Lenalidomide	Lenalidomide as monotherapy for maintenance treatment	N/A
Comparator(s)	Established clinical management without lenalidomide maintenance therapy (including monitoring and follow up)	Observation	N/A
Outcomes	The outcome measures to be considered include: <ul style="list-style-type: none"> • overall survival • progression-free survival • time to relapse or progression • adverse effects of treatment • health-related quality of life 	The outcome measures to be considered include: <ul style="list-style-type: none"> • overall survival • progression-free survival • adverse effects of treatment • health-related quality of life 	N/A
Economic analysis	The reference case stipulates that the cost effectiveness of treatments should be expressed in terms of incremental cost per quality-adjusted life year. The reference case stipulates that the time horizon for estimating clinical and cost effectiveness should be sufficiently long to reflect any differences in costs or outcomes between the	The reference case has been adhered to as described in Section B.3	N/A

	technologies being compared. Costs will be considered from an NHS and Personal Social Services perspective. The availability of any commercial arrangements for the interventions, comparator and subsequent treatment technologies will be taken into account.		
Subgroups to be considered	N/A	No subgroups considered.	N/A
Special considerations including issues related to equity or equality	Guidance will only be issued in accordance with the marketing authorisation. Where the wording of the therapeutic indication does not include specific treatment combinations, guidance will be issued only in the context of the evidence that has underpinned the marketing authorisation granted by the regulator.	N/A	N/A

ASCT, autologous stem cell transplantation; MM, multiple myeloma; N/A, not applicable; NICE, National Institute of Health and Care and Excellence.

B.1.2 Description of the technology being appraised

The summary of product characteristics (SmPC) and European public assessment report (EPAR) can be found in Appendix C.

Table 2 Technology being appraised

UK approved name and brand name	Lenalidomide (REVLIMID®▼)
Mechanism of action	Lenalidomide is an oral immunomodulatory imide drug (IMiD) based on the chemical structure of thalidomide that has anti-neoplastic, anti-angiogenic and proerythropoietic properties. ^{9,10} Lenalidomide inhibits the proliferation of certain haematopoietic tumour cells through binding to the ubiquitin E3 ligase cereblon. ¹¹ This induces the cereblon-mediated degradation of the lymphoid transcriptional factors, Ikaros (IKZF1) and Aiolos (IKZF3), which are essential for the differentiation of MM cells. ¹¹ It also inhibits the production of proinflammatory cytokines and enhances T cell- and Natural Killer cell-mediated immunity. ^{11,12}
Marketing authorisation/CE mark status	Lenalidomide was granted EMA marketing authorisation on the 26 January 2017 for the indication considered in this submission: lenalidomide as monotherapy is indicated for the maintenance treatment of adult patients with newly diagnosed multiple myeloma who have undergone autologous stem cell transplantation. ¹
Indications and any restriction(s) as described in the summary of product characteristics (SmPC)	<p>Indications</p> <p>Lenalidomide as monotherapy is indicated for the maintenance treatment of adult patients with newly diagnosed multiple myeloma who have undergone autologous stem cell transplantation.^{9,13} Maintenance treatment should be continued until progression or intolerance.¹³</p> <p>Other indications not covered by this submission include:</p> <ul style="list-style-type: none"> • Other multiple myeloma indications <ul style="list-style-type: none"> ○ Lenalidomide as combination therapy with dexamethasone, or bortezomib and dexamethasone, or melphalan and prednisone is indicated for the treatment of adult patients with previously untreated MM who are not eligible for transplant.¹³ ○ Lenalidomide in combination with dexamethasone is indicated for the treatment of MM in adult patients who have received at least one prior therapy.¹³ • Myelodysplastic syndromes <ul style="list-style-type: none"> ○ Lenalidomide as monotherapy is indicated for the treatment of adult patients with transfusion-dependent anaemia due to low- or intermediate-1-risk myelodysplastic syndromes associated with an isolated deletion 5q cytogenetic

	<p>abnormality when other therapeutic options are insufficient of inadequate.¹³</p> <ul style="list-style-type: none"> • Mantle cell lymphoma <ul style="list-style-type: none"> ○ Lenalidomide as monotherapy is indicated for the treatment of adult patients with relapsed or refractory mantle cell lymphoma.¹³ • Follicular lymphoma <ul style="list-style-type: none"> ○ Lenalidomide in combination with rituximab (anti-CD20 antibody) is indicated for the treatment of adult patients with previously treated follicular lymphoma (Grade 1–3a).¹³ <p>Restrictions</p> <ul style="list-style-type: none"> • Lenalidomide is contraindicated in patients with known hypersensitivity to the active substance or to any of the excipients,^a in women who are pregnant and women of childbearing potential unless all of the conditions of the pregnancy protection programme are met.¹³ • The SmPC describes in more detail other warnings and precautions, as well as dosing in special populations.¹³
<p>Method of administration and dosage</p>	<p>Oral treatment</p> <p>The recommended starting dose for lenalidomide maintenance therapy as detailed in the SmPC is 10mg once daily continuously (on days 1 to 28 of repeated 28-day cycles) given until disease progression or intolerance. After 3 cycles, the dose can be increased to 15mg orally if tolerated. This dosage recommendation is based on the registration trials, CALGB 100104 and IFM 2005-02,^{2,4} which were used to support the original EMA licence variation.^{9,13}</p> <p>This cost-effectiveness analysis underpinning this submission utilises a lenalidomide maintenance dosing schedule of 10 mg/day given on days 1–21 of a 28-day cycle. This is the schedule used in Myeloma XI⁵ and is thus expected to align with UK clinical practice. Further details regarding selection of this dosage regimen to inform the cost-effectiveness analysis can be found in section B.3.</p>
<p>Additional tests or investigations</p>	<p>Lenalidomide is structurally related to thalidomide, which is known to be a human teratogenic active substance that causes severe life-threatening birth defects. If lenalidomide is taken during pregnancy, a teratogenic effect of lenalidomide is expected. Lenalidomide is contraindicated in women of childbearing potential (and male partners), unless appropriate contraceptive measures and pregnancy testing are carried out:</p> <ul style="list-style-type: none"> • A medically supervised pregnancy test (with a minimum sensitivity of 25 mIU/mL) should be performed during the consultation when lenalidomide is prescribed, or in the 3 days prior to the visit to the prescriber once the patient has been using effective contraception for at least 4 weeks. The pregnancy test

B.1.3 Health condition and position of the technology in the treatment pathway

B.1.3.1 Overview of the disease

Multiple myeloma (MM) is a rare, incurable, malignant haematological disease arising from the monoclonal expansion of plasma cells in the bone marrow.^{15,16} In the UK, the incidence of MM continues to increase with a 30% rise in cases diagnosed since 1990.¹⁷ According to the Haematological Malignancy Research Network (HMRN), MM accounted for approximately 10% of the haematological malignancies diagnosed in the period 2010–2016,¹⁸ whilst data published by Cancer Research UK shows that MM represented 2% of all cancer cases diagnosed in 2014–2016.¹⁹

Table 3 presents the most recent UK incidence and mortality data for MM. In 2017, there were 5,289 new cases of MM diagnosed in England and Wales.

Table 3 Multiple myeloma incidence and mortality in England and Wales

	England	Wales
Incidence^a		
Cases 2016	4,731 ²⁰	249 ²¹
Cases 2017	5,034 ²⁰	255 ²¹
Deaths^a		
Cases 2016	2,606 ²⁰	154 ^{b,22}
Cases 2017	2,611 ²⁰	139 ²²

^a Based on myeloma (C90) code.

^b Calculation based on 2016 CRUK data (England & Wales).

CRUK, Cancer Research UK; N/A, not available; WCISU, Welsh Cancer Intelligence and Surveillance Unit.
Source: ONS,²⁰ WCISU,²¹ and CRUK.²²

MM is slightly more common in men accounting for approximately 57% of cases diagnosed in England.¹⁷ Primarily a disease of the elderly, 43% of incident cases in England in 2017 were in patients aged 75 years and over,²⁰ and the median age at diagnosis was around 73 years old.¹⁸ However, MM can also affect younger patients with approximately 27% of incident cases in England in 2017 diagnosed in patients younger than 65 years, of whom approximately 41% were women.²⁰ The 5-year survival rate in adults with MM in England and Wales is approximately 47%.²³

MM is recognised as an incurable disease and prolonging disease-free remission is thus a key treatment goal.

While treatment can result in remission, the course of MM in response to current treatment regimens is characterised by cycles of remission and relapse (Figure 1).²⁴ Many patients relapse owing to the continued presence of resistant malignant cells in the form of minimal residual disease (MRD). As the number of lines of therapy increases, the duration of response decreases and patients ultimately develop refractory disease.²⁴⁻²⁶ This pattern of relapse and remission and the presence of residual disease suggest that continuous therapy is required to suppress residual disease, maximise depth of response and prolong the first remission; a key factor in optimising patient survival.^{24,27,28}

Figure 1. Characteristic pattern of remission and relapse following conventional chemotherapy in multiple myeloma

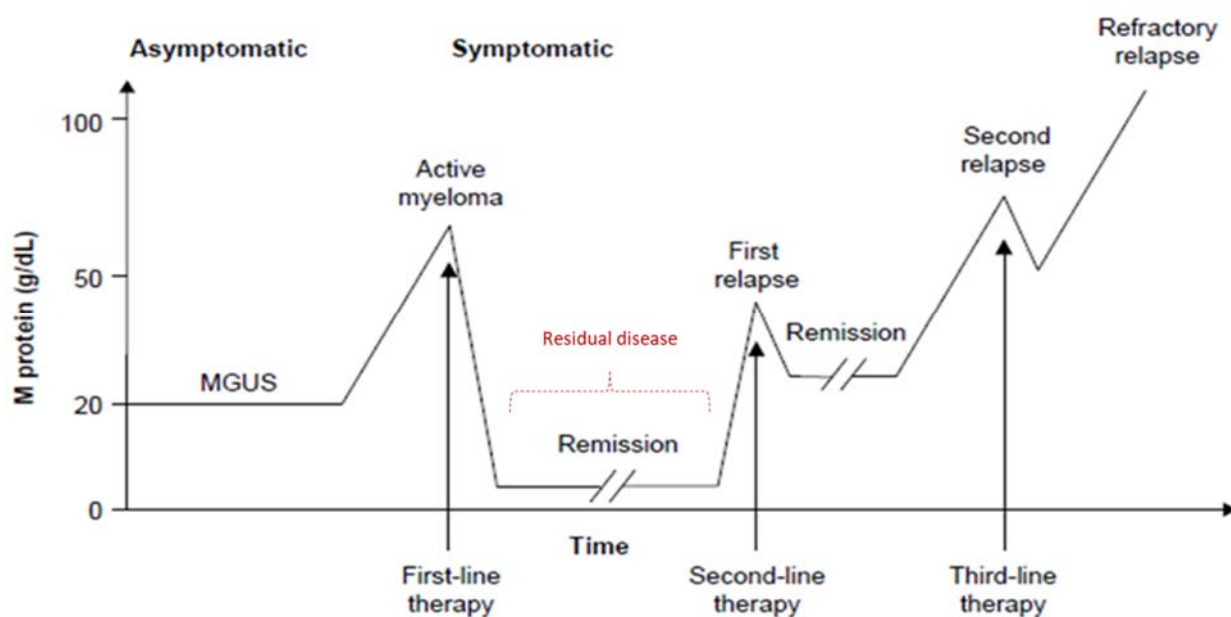

Therapeutic strategies are designed to eliminate the residual clonal cells that mediate relapse (residual disease, shown in red), with a view of extending the length of a patient's remission, especially the first remission where a patient usually experiences their best and longest clinical and quality of life improvements. Within this context, maintenance therapy after an ASCT offers an important treatment strategy.

Note: residual disease (or MRD) refers to residual myeloma cells located primarily in the bone marrow. The 2016 IMWG guidelines provide a range of criteria for use in detecting MRD in the bone marrow.²⁹

Key: IMWG, International Myeloma Working Group; MGUS, monoclonal gammopathy of undetermined significance; MRD, minimal residual disease.

Image source: adapted from Borello 2012.²⁴

B.1.3.2 Impact of disease and current treatments on patients and their carers

Patients with multiple myeloma suffer from a range of debilitating symptoms, including skeletal destruction, which arises from activation of osteoclasts by MM cells and leads to lytic bone lesions (80% of patients), pathological fractures (26%), bone pain (58%), mobility problems, osteoporosis (23%), impaired bone marrow function, hypercalcaemia (symptomatic or asymptomatic; 10–30% of patients), anaemia (75% of patients) and general ill health.^{25,30-32} Secretion of M-proteins by plasma cells results in renal insufficiency (up to 50%) and kidney failure, and patients are more susceptible to recurrent infections because of a compromised B-cell lineage.^{25,30,33}

The course of disease is not uniform and varies according to factors related to:

- the patient (age, frailty and renal function)^{25,34}
- tumour load, assessed by the International Staging System as well as Durie and Salmon stages of classification^{35,36}
- cytogenetic anomalies, including translocations 4;14 and 4;16, and deletion 17p^{37,38} (these high-risk cytogenetic anomalies were incorporated into a revised International Staging System in 2015)³⁹
- sensitivity of the tumour to treatment.⁴⁰

As the disease progresses, patients may also face a greater symptomatic burden owing to the cumulative toxic effects of treatment, such peripheral neuropathy.

Therapies aimed at alleviating disease and/or treatment-related symptoms can also impose a considerable burden on patients. Bone lesions and anaemia are frequently reported in patients with MM, and can be managed through bisphosphonates and blood transfusions; however, both treatments require intravenous administration and the burden of undergoing such treatments can have a substantial impact on patients' quality of life.⁴¹

One European study found that patients' symptom burden and comorbidities increased with each additional line of treatment, while the duration of the treatment-free interval decreased with successive lines of therapy.⁴² In addition, the period of first remission is generally when patients enjoy the best quality of life over the duration of their disease.^{26,43}

MM also has a significant emotional impact on patients, particularly when they relapse on their initial front-line treatment. In one study, patients reported feeling scared, depressed, worried, confused, frustrated and powerless.⁴⁴ Some patients in this study also reported that multiple relapses were associated with loss of hope as they felt they were “getting closer to the end”,⁴⁴ and similar emotional challenges have been reported for caregivers of patients with MM.⁴⁵ These issues are further highlighted by a recent study involving face-to-face interviews with 50 patients across the UK, France, Germany, Italy and Spain; all of whom had experienced a diagnosis and at least one clinical relapse of their MM.⁴⁶ As illustrated in Figure 2, patients’ well-being can be depicted by a series of peaks and troughs. For this particular patient, the highest peak post-diagnosis represents their first remission following stem cell transplant, while the troughs equate to periods of negative emotions following each relapse.

Figure 2 Changes in patient emotional and physical well-being over time

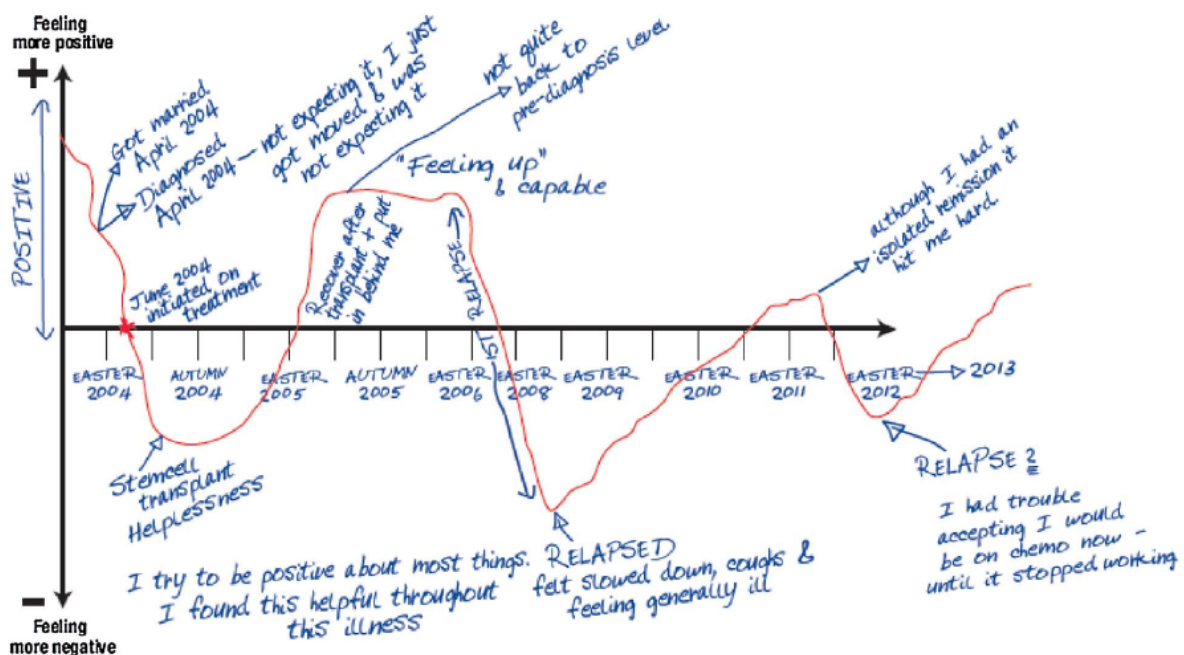

Note: Patients were asked to draw diagrams illustrating changes in their emotional and physical well-being over time. This example is a UK based MM patient’s diagram depicting their emotional journey. Patient diagnosed with MM nine years earlier, who had experienced two relapses (according to physician records).

Source: Hulin et al.⁴⁶

Taken together, this evidence supports the fact that prolonging the first remission period is crucial in providing long-term benefits and minimising the impact of MM on patients’ lives. This is echoed in NICE guidance TA228, where the committee stated

that “The main objective of first-line therapy is to achieve a period of stable disease (termed the plateau phase) for as long as possible, thereby prolonging survival and maximising quality of life”.⁴⁷

While considered a disease of the elderly, around a third of patients with MM are diagnosed before the age of 65. Younger patients can lose up to 30 years of life-expectancy due to MM compared with normal mortality expectations of respective populations adjusted for age, sex, year of diagnosis and nationality.⁴⁸

B.1.3.3 Clinical pathway of care and context of the proposed use of the technology

The UK myeloma treatment pathway illustrating the potential place of maintenance therapy, the technology under review, is shown in Figure 3.

Management of multiple myeloma is multi-phased. The approach to treatment of newly diagnosed multiple myeloma (NDMM) is dictated by a patient’s eligibility for ASCT with subsequent management based on this choice. For patients in good clinical condition (i.e.. fit patients [based on age, performance status and comorbidities]⁴⁹), induction followed by high-dose therapy (HDT) and ASCT is the standard treatment.⁵⁰ The majority of NDMM patients are deemed transplant non-eligible, whilst approximately 25–30%^{51,52} of all newly diagnosed patients receive an ASCT (see section B.1.3.3.2). International guidelines highlight the clinical benefits of maintenance therapy for patients who have undergone ASCT,^{50,53} but no active treatment is currently recommended by NICE and this represents an area of unmet clinical need (see section B.1.3.3.4 for further discussion on the role of maintenance therapy).

Lenalidomide is the only licensed maintenance treatment post-ASCT (see section B.1.3.3.4).⁹

B.1.3.3.1 Induction therapy

The primary aim of induction therapy is to induce a response and reduce tumour burden, thereby improving the likelihood of a successful ASCT.⁵⁴ Response rates to induction therapy have been significantly increased by the use of novel agent-based combinations.⁵⁰ Currently, three-drug regimens (such as bortezomib, thalidomide,

dexamethasone [VTD] as recommended by NICE guidance TA311⁵⁵) have shown improved efficacy over two-drug combinations⁵⁰ and are considered the standard for those likely to tolerate them.⁵⁶ Typically patients receive 4 to 6 cycles of induction therapy before proceeding to high-dose chemotherapy and stem cell collection.⁵⁰

B.1.3.3.2 High dose chemotherapy and stem cell transplantation

Autologous transplant using the patient’s own stem cells (i.e. ASCT), as opposed to allogenic transplant using donor stem cells, is the most common type of stem cell transplant used to treat MM.⁵⁷ British Society of Blood and Marrow Transplantation (BSBMT) data from 2018 records that a total of 1404 first-line ASCTs were performed in the UK and Republic of Ireland, compared with only 29 allografts in patients with MM (Table 4).⁵⁸

Table 4 First stem cell transplants given to patients with multiple myeloma in the United Kingdom and Republic of Ireland (2017–2018)

Disease category	Allograft			Autograft	
	BM	PB	CB	BM	PBSC
PCD: Myeloma (2018)	1	28	0	0	1404
PCD: Myeloma (2017)	1	42	1	1	1380

Note: BSBMT does not present data for tandem or salvage transplants.

Note: whilst data for non-1st transplants in PCD: Myeloma are not given, the overall rate of non-1st transplant autografts in 2018 (all categories) was 12.3% (346 of 2812), the rest being 1st line.

Key: BM, bone marrow; BSBMT, British Society of Blood and Marrow Transplantation; CB, cord blood; PB, peripheral blood; PBSC, peripheral blood stem cell; PCD: Plasma Cell Dyscrasias.

Source: BSBMT.⁵⁸

To prepare for ASCT, patients undergo peripheral blood stem cell collection with growth factor support (granulocyte colony-stimulating factor treatment), followed by myeloablative conditioning and reinfusion of collected stem cells.⁵⁹

Melphalan (200 mg/m² intravenous) is the standard conditioning high-dose chemotherapy (HDT) regimen before ASCT.⁵⁰ The aim of HDT-ASCT is to improve the depth of response to induction treatment, translating into improved response duration, and ultimately improved progression-free survival (PFS) and overall survival (OS).⁵⁹

Eligibility criteria for ASCT vary between healthcare providers but are generally based on age, performance status, and the presence of comorbidities.^{34,60} However, clinical guidelines do not limit the recommended age for ASCT. National Comprehensive Cancer Network (NCCN) guidelines state that advanced age is not a contraindication to transplant,⁵³ while European Society for Medical Oncology (ESMO) guidelines recommend ASCT in patients less than 65 years or less than 70 years if they are fit and in good clinical condition.⁵⁰ Historically, most transplantations have occurred in patients aged 60 years or younger, but there has been a trend in the past decade towards increased use of ASCT in patients aged over 60 years.⁶¹

Market research indicates that approximately 40% of patients with MM are eligible for ASCT, but that not all patients who meet eligibility criteria have a successful transplant (approximately 25–30% receive one).^{51,52} These results are consistent with a recent European survey which found that 44% of patients were considered by physicians to be eligible for SCT during their first line therapy, but only 31% went on to receive a transplant.⁵² This difference was even greater in the UK, with 54% of patients considered to be eligible for ASCT versus 30% actually receiving ASCT.⁵² Reasons why a high proportion of ASCT-eligible patients in the UK do not receive a transplant include factors such:

- failure to respond adequately to induction therapy
- failure to mobilise haematopoietic stem cells for collection (whilst 85–90% of patients mobilise readily,^{62,63} a significant minority do not
- progression from an ASCT-eligible to ineligible state (e.g. due to worsening co-morbidities, infections or declining organ function^{64,65}) from the time of initial assessment to scheduled ASCT.

Further discussion around technical parameters of ASCT (such as stem cell mobilisation, early vs late transplant) are provided in Appendix L.

B.1.3.3.3 Consolidation therapy*

Chemotherapy may be given for a short period after ASCT as consolidation therapy. Several trials indicate that consolidation therapy can improve the depth of response.⁵⁰ However, in the era of novel agent-based induction therapy, there is insufficient evidence for the systematic application of consolidation therapy.⁵⁰ Post-ASCT consolidation therapy thus remains controversial,⁵⁴ and is not endorsed nor routinely undertaken in the treatment of MM in the UK. In keeping with UK clinical practice, consolidation therapy was not used in Myeloma XI.⁵

B.1.3.3.4 Maintenance therapy

While induction followed by ASCT is the standard of care for the younger, fitter subset (~25–30%)^{51,52} of NDMM patients, it is not a cure. Patients typically experience disease progression within 2.5 years of transplant and have a life-expectancy of 5–7 years.^{4,34} Even in patients who achieve a complete response to their first-line treatment (induction and ASCT), residual disease persists following ASCT and is a central contributing factor to relapse.²⁷ The literature points to continuous suppression of residual disease and support of immunomodulatory functions to help improve the long-term outcomes of patients.⁶⁶⁻⁶⁸ As such, a strong clinical rationale exists for the use of immunomodulatory-based maintenance therapy, even in patients with MM who have a complete response after ASCT.

Maintenance therapy post-ASCT is therefore administered long-term with the biological goal of suppressing any MRD and with the clinical objectives of extending response duration, thereby prolonging PFS, and ultimately OS.⁶⁹

Because maintenance treatment is given for a prolonged period of time, tolerability and safety are key to its viability post-ASCT.⁷⁰ Maintenance duration is related to the tolerability of the intervention and, although the duration length has yet to be optimised, 2–3 years appears to be preferred.⁷¹ Cumulative toxicities arising from long-term exposure can lead to discontinuation and impact treatment duration.⁷²

* Note: in this submission, consolidation should not be confused with salvage therapy (used in patient with < partial response to induction therapy to bring about a sufficient response [≥ partial response] for patients to proceed to ASCT, see Figure 3), or intensification therapy, which can be considered the same as salvage therapy.

Lenalidomide (as a monotherapy) is not associated with significant peripheral neuropathy, unlike some other anti-myeloma treatments that have been evaluated in the maintenance setting and which has limited their long-term use.⁷¹ In this setting, a strong emphasis is also placed on convenience of administration and the lifestyle implications for patients associated with continuous treatment. The feasibility of dosing for an extended time may be limited by the route of administration. Lenalidomide has the benefit of being an oral therapy, and hence suitable for daily treatment.⁷³

Lenalidomide as maintenance therapy post-transplant is recommended in the 2017 ESMO guidelines,⁵⁰ and lenalidomide is recommended as the preferred maintenance therapy post-transplant by the 2019 NCCN guidelines⁷⁴ and 2019 American Society of Clinical Oncology (ASCO) and Cancer Care Ontario (CCO) guidelines.⁷⁵ Furthermore, lenalidomide monotherapy is the only maintenance therapy approved by the European Medicines Agency (EMA) in patients with newly diagnosed MM who have received an ASCT.

There is currently no published guidance on selecting patients for post-ASCT maintenance therapy. In clinical trials that have evaluated lenalidomide as post-ASCT maintenance therapy, the degree of response required for randomisation to maintenance treatment has consisted of either maintaining at least stable disease since ASCT (GIMEMA,³⁴ IFM 2005-02,³ CALGB 100104^{2,4}) or achieving a minimal response to ASCT (Myeloma XI).⁵

Note: It should be noted that the term 'maintenance' is only relevant in the transplant-eligible/post-ASCT setting. The term 'continuous' therapy is the preferred term for long-term treatment in the transplant ineligible setting, as was appraised in TA587.⁷ It is important to distinguish the two to avoid confusion.

B.1.3.3.5 Proposed place of lenalidomide maintenance therapy in the UK treatment pathway

Currently, no other pharmacological therapies are approved by the EMA as maintenance therapy post-ASCT, hence there are no active treatments

recommended by NICE and patients in England and Wales are managed through observation only. As such, lenalidomide will not displace any currently used first-line therapy (Figure 3).

Figure 3. Proposed place of lenalidomide maintenance therapy in the NHS England chemotherapy treatment algorithm

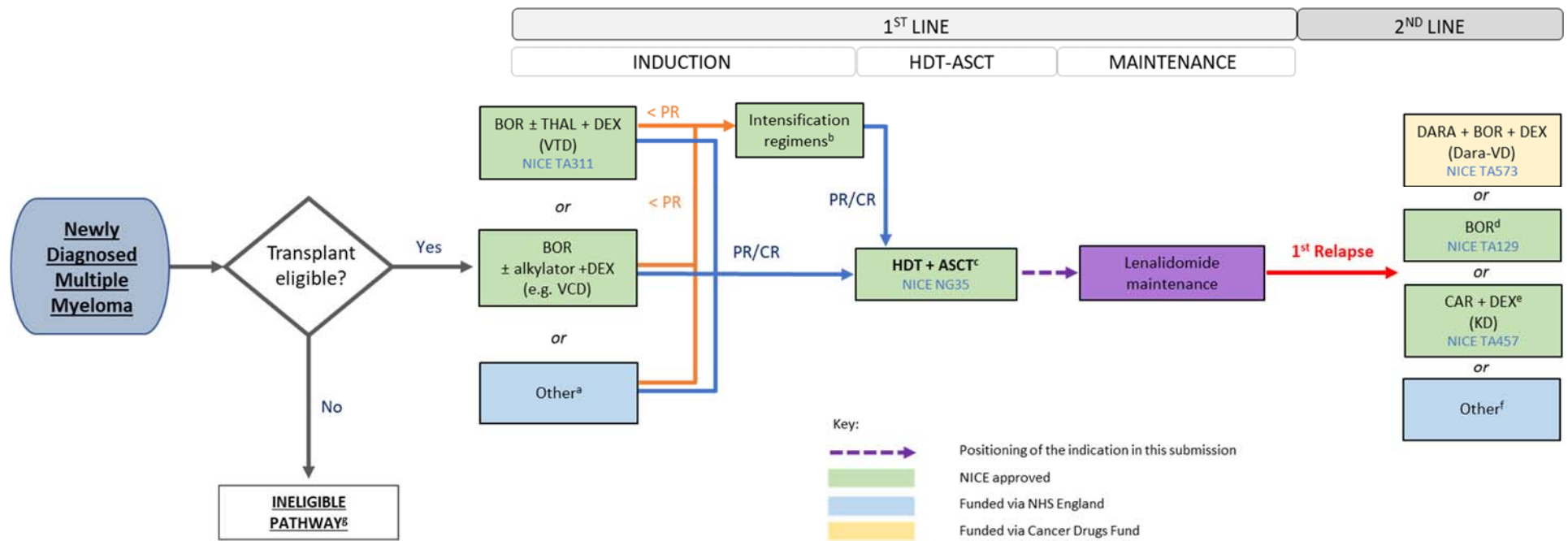

^a Although CTD was used in Myeloma XI (see section B.2) and listed in the relevant NHS treatment algorithm (Multiple Myeloma v0.7 2015), it is not a NICE recommended induction regimen nor is it licensed for such use. However, CTD was stated to be a standard induction regimen in the NICE committee discussion as part of TA311 (2014).⁵⁵

^b Also referred to as intensification therapy (see B.1.3.3.3), NHS treatment algorithm uses VCD or PAD, whilst Myeloma XI uses VCD. Thresholds vary e.g. Myeloma XI (< VGPR).

^c Preferred form of ASCT is PBSCT. In addition, a small proportion of patients may receive an allogeneic stem cell transplant (see Table 4).

^d Frequently given with dexamethasone i.e. VD.

^e If previous treatment did not include BOR.

^f Can include watchful waiting or observation. The NHS treatment algorithm also recommends CTD, PAD or a LEN based regimen (e.g. RD).⁷⁶ However, the latter should be used in transplant ineligible patients with prior BORT, as discussed in TA586 (2019).⁶

^g Not relevant to this submission.

Note: pathway does not include 2nd ASCT.

Key: ASCT, autologous stem cell transplant; BOR, bortezomib; CR, complete response; CTD, cyclophosphamide, thalidomide and dexamethasone; Dara-VD, daratumumab and bortezomib and dexamethasone; DEX, dexamethasone; HDT, high-dose therapy; LEN, lenalidomide; NICE, National Institute for health and Care Excellence; PAD, bortezomib and doxorubicin and dexamethasone; PBSCT, peripheral blood (autologous) stem cell transplant; PR, partial response, RD, lenalidomide and dexamethasone; VCD, bortezomib/cyclophosphamide/dexamethasone; VD, bortezomib and dexamethasone; VGPR, very good PR; VTD, bortezomib and thalidomide and dexamethasone.

Source: adapted from National Chemotherapy Algorithms - NHS England (Multiple Myeloma, v0.7 2015)⁷⁶ and relevant NICE guidance to 2019.^{6,55,77-80}

B.1.3.4 Clinical guidelines relevant to this submission

A number of clinical practice guidelines are available on the management of multiple myeloma which include guidance on maintenance therapy for patients who have undergone ASCT.^{25,50,74,75,81}

United Kingdom guidelines

In 2013, the joint British Committee for Standards in Haematology (BCSH) and UK Myeloma Forum (UKMF) issued guidelines on the management of MM including maintenance therapy.²⁵ This was prior to data being reported from studies evaluating lenalidomide in the maintenance setting (CALGB 100104, IFM-2005-05). A revised version of the BCSH guidelines (now the British Society for Haematology [BSH]) is currently under development and due to be released in 2020. The BSH has also published guidance on management of the long-term complications of MM (2017),⁸² many of which are relevant to the post-ASCT setting. However, these guidelines do not include specific recommendations on anti-myeloma therapies and are therefore not discussed in this section.

The 2013 BCSH guidelines have since been superseded by international guidelines published by ESMO, 2017,⁵⁰ the NCCN 2019,⁷⁴ and the American Society of Clinical Oncology and Cancer Care Ontario (ASCO–CCO, 2019),⁷⁵ all of which make recommendations regarding post-ASCT maintenance therapy.

European guidelines

The 2017 ESMO guidelines recommend the use of lenalidomide as maintenance therapy following ASCT in patients less than 65 years old or less than 70 years old (if patients are in good clinical condition).⁵⁰ This recommendation was based on high quality and strong evidence (level 1A) of an improvement in PFS and OS,^{49,83} which has been further supported by a more recent meta-analysis,⁸⁴ and is in line with the EMA's approval of lenalidomide as maintenance therapy post-ASCT.⁹

The 2017 European Myeloma Network (EMN) guidelines also recommend lenalidomide (level 1A evidence), for maintenance therapy post-ASCT (for at least 2 years or until tolerated).⁸¹

North American Guidelines

The 2019 NCCN guidelines for MM (version 1.2020) recommend lenalidomide as the preferred maintenance therapy post-ASCT,⁷⁴ based primarily on high-level evidence (category 1) from two phase 3 studies, CALGB 100104 (NCT00114101)² and IFM-2005-02 (NCT00430365).^{3 4}

Similarly, the 2019 joint ASCO–CCO guidelines provide a strong recommendation for the use of lenalidomide as maintenance therapy for standard-risk patients, starting approximately day 90–110 post ASCT at 10–15 mg until progression (evidence quality: high, benefit outweighs harm).⁷⁵ Furthermore, the supporting evidence suggests that patients who receive lenalidomide as part of induction therapy may experience an additional treatment benefit from maintenance therapy with lenalidomide.⁷⁵

B.1.4 *Equality considerations*

No equality issues relating to the use of lenalidomide have been identified or are anticipated.

B.2 Clinical effectiveness

B.2.1 Identification and selection of relevant studies

Appendix D provides full details of the systematic literature review (SLR) used to identify and select clinical evidence relevant to this submission.

Of the four studies that assessed lenalidomide maintenance identified by the SLR (eligibility criteria given in Appendix D), only a single study (Myeloma XI⁵) was considered relevant to the decision problem specified in the final scope (Section B.1, Table 1). Three additional studies (CALGB 100104,^{2,4} GIMEMA,³⁴ and IFM 2005-02³) that also assessed lenalidomide maintenance therapy, two of which (CALGB 100104 and IFM 2005-02) were used to support the EMA label extension for lenalidomide as maintenance therapy, in patients with newly diagnosed MM following ASCT⁸⁵ were also identified.

Myeloma XI is the only study that accurately reflects the decision problem (Section B.1, Table 1) and current UK clinical practice in treating patients with MM. This is based on the considerations detailed in Table 5 (and in further detail in appendix D [Table 39, Table 40 and Figure 24]) and discussed below. Thus, Myeloma XI will be presented in detail in section B.2.3 onwards and provides the primary source of clinical data used to inform the economic model (presented in section B.3). Of the other studies, CALGB 100104 was considered relevant for economic model validation purposes (see section B.3) because it had the longest follow up,^{2,84} and importantly, it was the only other study, in addition to Myeloma XI, which replicated the UK care pathway reasonably closely for this patient population (using no consolidation, conducted in people who underwent ASCT and maintenance treatment given until progression) although still using a 28 days maintenance protocol. By comparison, care pathways used in GIMEMA and IFM2005-02 were substantially different than those pertinent with the UK setting.

Table 5. Comparison of CALGB 100104, IFM 2005-02, GIMEMA and Myeloma XI.

	CALGB 100104	IFM 2005-02	GIMEMA	Myeloma XI
UK patients as proportion of study (%)	0 ^a	0 ^a	0 ^a	100

Study powered for detecting survival difference?	No	No	No	Yes ^b
Patient cross-over before PD allowed ^c	Yes	No	No	No
Early discontinuation	No	Yes ^d	No	No
Lenalidomide dose cycle ^e	1–28 of a 28-day cycle	1–28 of a 28-day cycle	1–21 of a 28-day cycle	1–21 of a 28-day cycle
Consolidation therapy (non-UK practice) ^f	No	No	Yes	No

^a CALGB 100101 was a US study, IFM 2005-02 a French/Swiss/Belgian and GIMEMA an Italian/Israeli.

^b Co-primary endpoint. Myeloma XI is the only RCT of date power to detect a survival difference in patients treated with maintenance therapy.

^c Confounds survival analysis.

^d IFM 2005-02 was stopped early (~2 years) due to safety concerns.

^e See section B.3 for RDI information. Overall patients in CALGB 100104 and IFM 2005-002 were exposed to more intensive treatment than expected in UK clinical practice.

^f See section B.1.3.3.3.

Shaded cells represent trial attributes consistent with decision problem, reflective of anticipated UK clinical practice or desirable statistical feature, as detailed in footnotes.

PD, progressive disease; RCT, randomized controlled trial.

B.2.1.1.1 UK population

The Myeloma XI population was based entirely in the UK at 110 sites in England, Scotland and Wales.⁵

B.2.1.1.2 Lenalidomide schedule and dosing

Specifically, Myeloma XI reflects real-world dosing regimens, treatment duration and clinical experience specific to UK practice. The lenalidomide maintenance regimen in Myeloma XI is 10 mg on days 1–21 of a 28-day cycle.⁵ In contrast, the registration trials (IFM 2005-02³ and CALGB 100104^{2,4}) use a lenalidomide regimen as per the EMA maintenance indication (days 1–28 of a 28-day cycle).¹ Overall patients in CALGB 100104 and IFM 2005-002 were exposed to more intensive treatment (see section B.3).²⁻⁴

B.2.1.1.3 UK clinical practice

Myeloma XI was the only study that used a treatment pathway relevant to UK clinical practice.

- *Myeloma XI*⁵ – Included patients who received induction therapy plus ASCT with no consolidation therapy post-ASCT; therefore the population in Myeloma XI reflects that stated in the decision problem and expected to be treated in UK clinical practice.
- *IFM 2005-002*³ – Patients received consolidation therapy post-ASCT with lenalidomide 25 mg (days 1–21 of a 28-day cycle) before randomisation to maintenance therapy, which does not reflect UK clinical practice.
- *GIMEMA*³⁴ – all patients were randomised to either six cycles of MPR (melphalan [0.18 mg/kg, days 1–4] plus prednisone [2 mg/kg, days 1–4] plus lenalidomide [10 mg, days 1–21 of a 28-day cycle]) or HDT plus ASCT (two 4-month cycles of melphalan [200 mg/m²] plus ASCT); therefore only half of patients in GIMEMA, who were subsequently randomized to maintenance or observation, had undergone an ASCT.

B.2.1.1.4 Study powered to detect differences in patient survival

Of the trials identified by the SLR, Myeloma XI is the only trial powered to detect a survival advantage for lenalidomide in ASCT-eligible patients; as such it addresses current uncertainty regarding the OS benefit of maintenance therapy.⁵ The magnitude of the OS benefit for lenalidomide maintenance varied across CALGB 100104, IFM 2005-02 and GIMEMA.^{2-4,34} GIMEMA did not report any survival difference with maintenance therapy; however, only about half of patients who received maintenance therapy received an ASCT³⁴ introducing substantial bias into the comparison of the three trials. Owing to the uncertainty in survival advantage, the Food and Drug Administration (FDA) requested a meta-analysis using patient-level data from all three trials, powered to detect a treatment effect on OS.⁸⁴ The results of the meta-analysis of 1208 patients receiving lenalidomide maintenance suggested that lenalidomide was associated with a statistically significant advantage in median OS compared with observation⁸⁴ although it should be noted that there was substantial heterogeneity in the study designs of the three trials. The results of Myeloma XI further support the survival benefit of lenalidomide maintenance demonstrating a statistically significant improvement in survival in the ASCT-eligible population relevant to the decision problem.⁵

B.2.1.1.5 Study design considerations.

Myeloma XI did not allow patients to switch from observation to lenalidomide following disease progression, whilst treatment-switching (prior to disease progression) was permitted in CALGB 100104.^{2,4,5}

B.2.2 List of relevant clinical effectiveness evidence

Details of Myeloma XI are given in Table 6. The population of interest are those patients eligible for an ASCT (Myeloma XI included both patients eligible and ineligible for ASCT, termed by Myeloma XI as intensive and non-intensive pathways, respectively). Furthermore, to fully align with the decision problem, the clinical evidence presented in this dossier is focussed on patients who received 10 mg lenalidomide maintenance after ASCT, from protocol Version 5.0 onwards (see definition given in Table 7 and illustration in Figure 4).

Table 6. Summary of clinical effectiveness evidence (Myeloma XI)

Study	Myeloma XI (NCT01554852) ⁵
Study design	Phase 3, multicentre, open-label, adaptive-design randomised clinical trial
Population of interest^a	Patients with newly diagnosed MM eligible for an ASCT (assessed on an individual patient basis dependent on performance status, clinical assessment and patient preference)
Intervention used in subgroup of interest	<p><i>Randomisation 1:</i> Induction therapy (allocation by transplantation eligibility status)</p> <ul style="list-style-type: none"> Intensive pathway (transplantation-eligible): randomisation to either CTD, RCD or KCRD Non-intensive pathway (transplantation-ineligible): randomisation to CTDa or RCDA <p><i>Randomisation 2:</i> intensification therapy (if required, allocation based on response to induction therapy)</p> <ul style="list-style-type: none"> Partial or minimal response to CTD or RCD^b (both intensive and non-intensive pathway: VCD <p>Randomisation 3: maintenance therapy (allocation by response to induction plus intensification)</p> <ul style="list-style-type: none"> Intensive pathway: maximum response following induction therapy with or without intensification therapy and at least 100 mg/m² high-dose melphalan. Non-intensive pathway: maximal response to randomisation
Comparator(s)	<p><i>Randomisation 1:</i> all patients were randomized to active treatment</p> <p><i>Randomisation 2:</i> no intensification</p>

Company evidence submission for post-ASCT maintenance with lenalidomide (ID475)

<i>Randomisation 3: observation</i>					
Indicate if trial supports application for marketing authorisation	Yes		Indicate if trial used in the economic model	Yes	X
	No	X		No	
Rationale for use/non-use in the model	A reanalysis of the maintenance stage of the Myeloma XI trial including data collected from protocol version 5.0 onwards was used in the model, which is most reflective of the decision problem of the identified studies (i.e. removal of patients not strictly treated with 10 mg lenalidomide), see Table 7 for a complete description. ⁸⁶				
Reported outcomes specified in the decision problem	PFS, OS, adverse events.				
All other reported outcomes	PFS2, response rate.				

^a Myeloma XI also included patients who were ineligible for ASCT, these patients are not considered as part of this submission and are not detailed in this table.

^b Patients who were allocated to KCRD did not undergo randomisation to intensification therapy.

CTD, attenuated cyclophosphamide, thalidomide, and dexamethasone; aRCD, attenuated lenalidomide, cyclophosphamide and dexamethasone; ASCT, autologous stem cell transplantation; CTD, cyclophosphamide, thalidomide, and dexamethasone; KCRD, carfilzomib, cyclophosphamide, lenalidomide and dexamethasone; OS, overall survival; MM, multiple myeloma; PFS, progression-free survival; PFS2, time to second objective disease progression; RCD, lenalidomide, cyclophosphamide and dexamethasone; VCD, bortezomib, cyclophosphamide and dexamethasone.

Source: Jackson *et al*, 2019;⁵ Celgene, 2019.⁸⁶

The Myeloma XI study is the source of data for this submission, the methodology of which is described in section B.2.3. In line with the scope of the submission, data are presented for patients that are aligned with the population defined by the decision problem, as detailed in Table 7, and referred to simply as Myeloma XI from this point onwards.

However, the methodology of the Myeloma XI study is presented for the maintenance randomisation as per the intention-to-treat (ITT) comparison. Furthermore, for completeness, details of the ITT data (as published) are also provided in Appendix M.8 as well as a general overview of the entire Myeloma XI study (Appendix M.1 though M.7).

Table 7 Myeloma XI: cohort relevant to decision problem

<p>This cohort includes patients who:</p> <ul style="list-style-type: none"> entered the intensive pathway

Company evidence submission for post-ASCT maintenance with lenalidomide (ID475)

- completed randomized induction (with or without intensification therapy as per the protocol)^a
- achieved a maximum response^b to induction therapy (with or without intensification therapy)^a
- were subsequently randomized to maintenance with lenalidomide 10 mg or observation under protocol Version 5.0 onwards (14 September 2011).

This analysis differs from the overall published maintenance analysis as it excludes the following patients:

1. Patients in the non-intensive treatment pathway (ineligible for ASCT).
2. Patients randomized to maintenance with lenalidomide 25 mg or observation before protocol Version 5.0.
3. Patients randomized to maintenance with lenalidomide and vorinostat (discontinued with protocol Version 6.0 (28 June 2013)).

^a see section B.1.3.3.3 for clarification on differentiating between intensification, consolidation and salvage therapy.

^b Myeloma XI specific term.

Key: ASCT, autologous stem cell transplant.

B.2.3 Summary of methodology of the relevant clinical effectiveness evidence

B.2.3.1 Study design

Myeloma XI (NCT01554852) is an adaptive-design randomized, multicentre, open-label clinical trial in patients newly diagnosed with MM.⁵ The study comprised two pathways (intensive pathway: ASCT-eligible patients; non-intensive pathway: ASCT-ineligible patients), and three randomisation stages (Table 6).

The decision of treatment pathway (intensive or non-intensive) was made on an individual patient basis based and took into account Eastern Cooperative Oncology Group (ECOG) performance status, clinical judgement and patient preference as assessed by the recruiting physician.⁵

The following key protocol amendments relating to study treatment and dosing were made during the study.⁵

- Initially patients were randomized 1:1 to receive maintenance with oral lenalidomide 25 mg daily (days 1–21 of a 28-cycle) or observation.
- The dosage was subsequently reduced to 10 mg daily (days 1–21 of a 28-day cycle) following a protocol amendment (version 5.0; 14 September 2011).

Company evidence submission for post-ASCT maintenance with lenalidomide (ID475)

- An additional treatment arm, lenalidomide 10 mg plus vorinostat 300 mg, was also introduced: patients were randomized 1:1:1 to either maintenance with lenalidomide 10 mg daily, lenalidomide 10 mg and vorinostat 300 mg daily, or observation (Version 5.0; 14 September 2011; Figure 4).
- A further protocol amendment, suspended randomisation of new patients to lenalidomide 10 mg plus vorinostat 300 mg (version 6.0; 28 June 2013).

The reduction in lenalidomide dose from 25 mg to 10 mg was motivated by emerging efficacy results from other studies that used lenalidomide 10 mg, weighted against the potential for late toxicity, which was reported at the time.⁵

This submission includes only patients in the intensive pathway eligible for maintenance therapy (randomisation stage 3) who were randomized 2:1 to receive lenalidomide 10 mg daily on days 1–21 of a 28-day cycle or observation from protocol Version 5.0 onwards (Figure 4). Lenalidomide was given orally until disease progression in the absence of toxicity. All analyses included are those pertinent to the population as defined by the scope of the submission, unless otherwise specified.

Figure 4. An overview of the maintenance phase of the Myeloma XI trial (protocol Version 5.0 onwards)

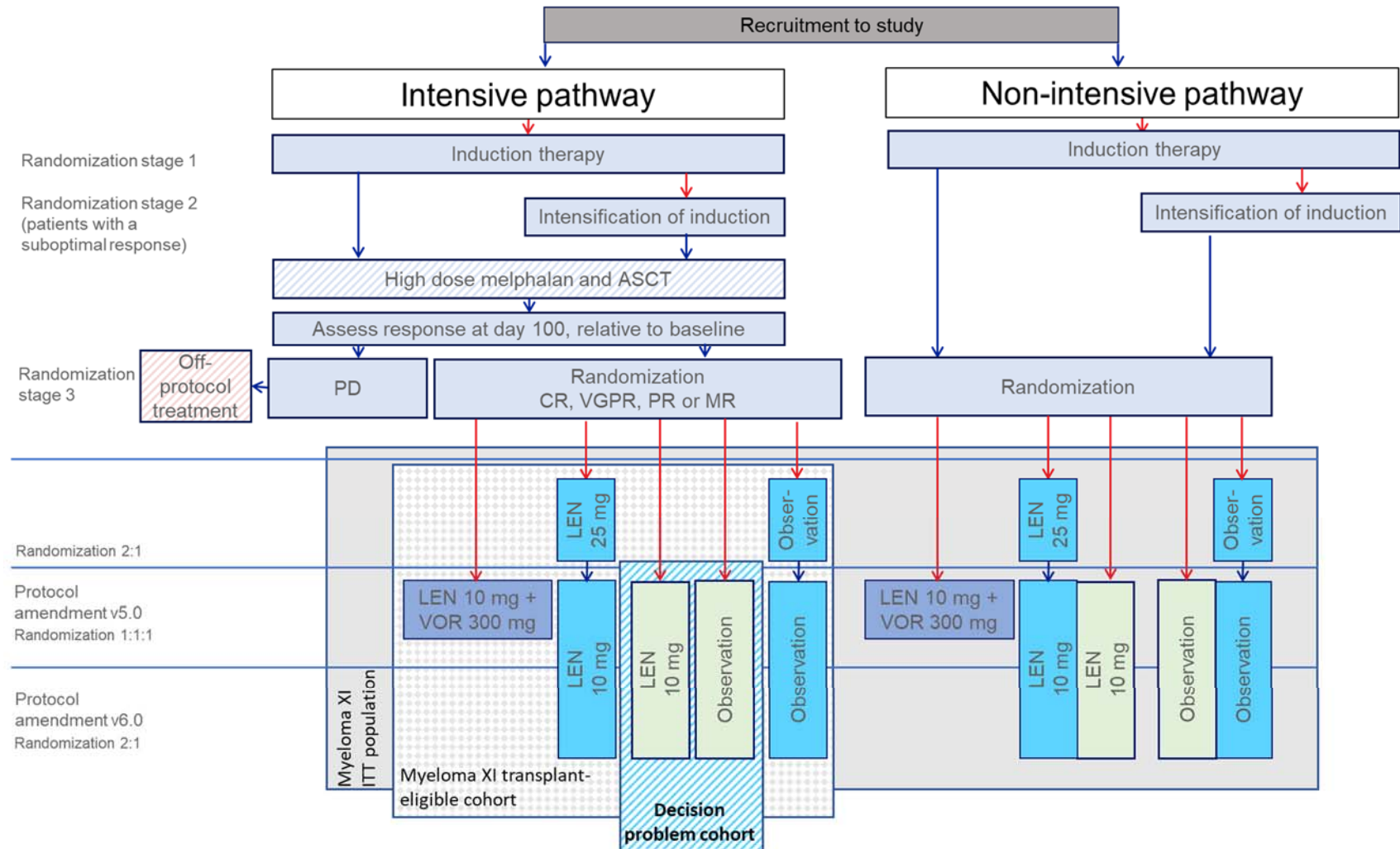

ASCT, autologous stem cell transplant; CR, complete response; LEN, lenalidomide; MR, minimal response; PD, progressive disease; PR, partial response; VGPR, very good partial response; VOR, vorinostat.

Source: Adapted from Jackson *et al*, 2019⁵

Company evidence submission for post-ASCT maintenance with lenalidomide (ID475)

© Celgene (2020). All rights reserved

B.2.3.2 Eligibility criteria for the maintenance therapy in Myeloma XI

The key inclusion and exclusion criteria for patients enrolled in the Myeloma XI study are presented in Table 8. Additional inclusion and exclusion criteria for maintenance randomisation are given in Appendix M.

Table 8. Key eligibility criteria for maintenance therapy in Myeloma XI

Inclusion criteria	Exclusion criteria
<p>Patients aged ≥ 18 years with newly diagnosed symptomatic MM or non-secretory MM based on:</p> <ul style="list-style-type: none"> • bone marrow clonal plasma cells; • organ or tissue impairment and/or symptoms considered by a clinician to be myeloma-related; • presence of paraprotein (M-protein) in serum or urine. 	<p>Previous or concurrent malignancies, including:</p> <ul style="list-style-type: none"> • myelodysplastic syndromes; • \geq grade 2 peripheral neuropathy; • acute renal failure (unresponsive to up to 72 h of rehydration based on creatinine $> 500 \mu\text{mol/L}$ or urine output $< 400 \text{ mL}$ per day, or requiring dialysis); • lactation or breast feeding • active or previous hepatitis C.
Additional criteria for maintenance randomisation	
<ul style="list-style-type: none"> • Patients with maximum response to a minimum of 4 cycles of randomized induction therapy with CTD, RCD or KCRD with or without up to 8 cycles of VCD. 	<ul style="list-style-type: none"> • Progressive disease or no change following lenalidomide induction therapy (component of KCRD) • Failed response to all protocol treatment (i.e. no response to any treatment following enrolment into Myeloma XI) • Receipt of any anti-myeloma treatment other than randomized trial treatment • Progressive disease or relapse from complete response.

CTD, cyclophosphamide, thalidomide and dexamethasone; h, hour; KCRD, carfilzomib, lenalidomide, cyclophosphamide and dexamethasone; RCD, lenalidomide, cyclophosphamide and dexamethasone; MM, multiple myeloma; VCD, bortezomib, cyclophosphamide and dexamethasone.

Source: Jackson et al, 2019⁵

B.2.3.3 Myeloma XI study locations and setting

The Myeloma XI study was co-sponsored by Cancer Research UK, Celgene, Amgen, Merck and Myeloma UK.⁵ Celgene Corporation provided unrestricted educational grants that supported trial coordination and laboratory studies.⁵ Overall, the study enrolled 4,420 patients, of which 1,971 underwent maintenance randomisation at 110 National Health Service hospitals in England, Wales and Scotland.⁵ The study was

entirely UK-based and therefore the results are applicable to UK clinical practice. A full list of sites can be found at ClinicalTrials.gov.⁸⁷

B.2.3.4 Myeloma XI maintenance study drugs and concomitant medicines

The protocol treatments used in the Myeloma XI maintenance arm (per decision problem) are given in Table 9.

Table 9. Study maintenance drug, dose and duration

	Study drug dosing	Treatment duration
Maintenance with lenalidomide	Lenalidomide 10 mg, days 1–21/28-day cycle (protocol Version 5.0 onwards)	In the absence of toxicity, lenalidomide is continued until disease progression.

Source: Jackson *et al*, 2019.⁵

On-treatment dose adjustments were allowed in case of adverse reactions. Treatment was discontinued in the presence of grade 3 or 4 neutropenia and for a platelet count of less than $30 \times 10^9/L$; on recovery delayed treatment was restarted at the previous dose (with the addition of granulocyte colony-stimulating factor in the case of grade 3 neutropenia with fever or grade 4 neutropenia). Upon neutropenia or thrombocytopenia recurrence, the dose was reduced by one dose level (e.g. from 10 mg to 5 mg daily) according to the dose adjustments given in Table 10.⁵

Table 10. Dose reduction recommendations

	Lenalidomide alone (10 mg starting dose)
Starting dose	10 mg
Dose level -1	5 mg
Dose level -2	5 mg every other day
Dose level -3	Discontinue

Note: A full description of dose reductions is given in Appendix M.

Source: Jackson *et al*, 2019.⁵

Concomitant treatment with bisphosphonates and thromboprophylaxis were allowed according to investigator's choice. Human granulocyte colony-stimulating factor support and prophylaxis for pneumonia, varicella, fungal infection and tumour lysis were allowed as per local practice (see Appendix M).⁸⁷ Concomitant use of other anti-myeloma therapy or investigational drugs during receipt of study treatment was prohibited.⁵

B.2.3.5 Outcome measures

The outcome data presented in the submission are as follows:

- *Efficacy*
 - PFS: analysis of patients randomized to lenalidomide or observation under protocol Version 5.0 onwards
 - OS: analysis of patients randomized to lenalidomide or observation under protocol Version 5.0 onwards

- *Safety*
 - Patients randomized to lenalidomide or observation under protocol Version 5.0 onwards who received at least one dose of lenalidomide as maintenance therapy

Data are presented for the 23 October 2017 data cut unless otherwise specified. There have been no relevant data cuts since this time. The final analysis is expected in 2022.

Table 11 summarises the outcome measures pertinent to the scope of this submission, relevant outcome data available and the data used in the economic model.

PFS, PFS2 and OS data for the Myeloma XI ITT population are available in Appendix D and M8. Results of subgroup analyses for ASCT-eligible subgroup are presented in Appendix D and M9, whilst a complete ITT subgroup analysis is shown in Appendix E.

Table 11. Outcome measures available from Myeloma XI and their inclusion into the economic model

Endpoint	Efficacy measures	Description	Data cut available	Used in economic model
Co-primary	PFS	Time from maintenance randomisation to progressive disease or death from any cause. Progression determined by the investigator according to the Modified International Uniform Response criteria of Response and Progression (based on Blade <i>et al</i> , 1998; Durie <i>et al</i> , 2006; Rajkumar <i>et al</i> , 2011). ⁸⁸⁻⁹⁰ Progression was measured at the start of each treatment cycle and every 28 days during follow-up.	Investigator assessment 23 October 2017 ^a Central review 23 October 2017	Investigator assessment 23 October 2017
	OS	Time from maintenance randomisation to death from any cause or last follow-up. Participants discontinuing protocol treatment, receiving non-protocol treatment or suffering a second malignancy were followed for OS unless they explicitly withdrew consent.	23 October 2017	23 October 2017
Secondary	PFS2 ^b	Defined as the time from maintenance randomisation to the date of: <ul style="list-style-type: none"> • second progressive disease • start of third antimyeloma treatment • or of death from any cause, whichever was first. 	23 October 2017	×
	Response rates	Response based on Modified International Uniform Response criteria of Response and Progression, ⁸⁸⁻⁹⁰ using local responses based on samples of blood, urine and bone marrow and other clinical assessments. Response was assessed as: complete response; very good partial response; partial response; minimal response; no change; progressive disease.	×	×
Safety	Toxicity	Reported based on adverse events, as graded by CTCAE V4.0 and determined by routine clinical assessment at each centre	23 October 2017	23 October 2017

^a However, this is not available for the Myeloma XI cohort presented in B2.6.

^b PFS2 data were not available for the Myeloma XI cohort presented in B2.6 but is shown in Appendix D for the Myeloma ITT and key ASCT-eligible subgroup.

CTCAE, common terminology for adverse events; ITT, intention to treat; OS, overall survival; PFS, progression-free survival; PFS2, time to second objective disease progression.

Source: Myeloma XI trial patient-level data analysis 2019⁸⁶ and Jackson *et al*, 2019.⁵

Company evidence submission for post-ASCT maintenance with lenalidomide (ID475)

B.2.3.6 Summary of Myeloma XI methodology

The Myeloma XI study methodology is summarised in Table 12.

Table 12. Summary of Myeloma XI methodology

Study details	Myeloma XI (NCT01554852) ⁵
Location	110 NHS hospitals in England, Wales and Scotland
Design	Phase 3, multicentre, open-label, adaptive-design UK study with three randomisation stages that assessed the efficacy and safety of different induction and intensification therapies with or without an ASCT followed by maintenance therapy with lenalidomide or observation.
Duration of maintenance follow-up	31 months (IQR, 18–50). Follow-up until disease progression.
Method of randomisation	<p>At enrolment, patients were recruited to the intensive pathway, if ASCT-eligible, or the non-intensive pathway, if not ASCT-eligible based on assessment by the recruiting physician.</p> <p>A centralized Clinical Trials Research Unit automated 24-hour telephone system was used to allocate participants to:</p> <ul style="list-style-type: none"> • Maintenance therapy: <ul style="list-style-type: none"> ○ randomisation 1:1 to lenalidomide 25 mg (1–21/28 days) or observation (protocol Version 2.0–4.0 until 13 September 2011) ○ randomisation 1:1:1 to lenalidomide 10 mg (1–21/28 days) or observation or lenalidomide 10 mg plus vorinostat 300 mg (protocol Version 5.0 until 28 June 2013) ○ randomisation 2:1 to lenalidomide 10 mg (1–21/28 days) or observation (protocol Version 6.0 until 11 August 2017) <p>Treatments were randomly allocated using validated computer-generated minimisation algorithms.</p> <p>Randomisation was stratified by treatment centre, allocated induction treatment (CTD vs RCD vs KCRD vs aCTD vs aRCD) and allocated intensification treatment (CVD vs no CVD).</p> <p>All Myeloma XI stratification details are presented in Appendix M.</p>
Blinding	<p>Open label study: investigators and patients were not masked to treatment allocation.</p> <p>Funders remained masked to treatment results until data cut-off for analysis.</p>

	Analyses of the Myeloma XI cohort used in this submission (see Table 7) were conducted unblinded to treatment allocation.
Maintenance treatment	<p>Oral lenalidomide 10 mg/day on days 1–21 of each 28-day cycle given continuously until disease progression or unacceptable toxicity.</p> <p>Dose adjustments were made dependent on renal function, and neutrophil and platelet counts. Dose delays and reductions were permitted in the case of study treatment toxicity.</p> <p>Antithrombotic prophylaxis was recommended for the first 3 months of study treatment as per the IMWG recommendation.</p> <p>Bisphosphonates and other supportive therapies were allowed at the discretion of the investigator.</p> <p>No switching between treatment groups was allowed.</p>
Co-primary endpoints	PFS and OS
Primary and secondary comparisons	For the co-primary endpoints, estimated summaries of time to event per treatment group were made using the Kaplan–Meier method. Comparisons between the allocated groups were made using the Cox proportional hazards model stratified by the minimization stratification factors, excluding centre, and to estimate hazard ratios and 95% CIs.
Subgroup analyses	<p>Prespecified subgroup analyses (ITT population) included:</p> <ul style="list-style-type: none"> • individual adverse cytogenetic abnormalities (e.g. chromosome 14 translocations and abnormalities of chromosome 1p, 1q, 13q and 17p) • cytogenetic risk status (standard risk [no adverse cytogenetic abnormalities], high risk [one adverse cytogenetic abnormality] or ultra-high risk [two or more adverse cytogenetic abnormalities]) • induction/intensification treatment prespecified in the statistical analysis plan within each pathway <p>Exploratory analysis of PFS, OS, PFS2 by sex, age and disease stage according to the International Staging System, and response at start of maintenance.</p>
Duration of follow-up	2 years following recruitment of the last participant into the trial, estimated at 4 years.

ASCT, autologous stem cell transplantation; CI, confidence interval; CTD, cyclophosphamide, thalidomide and dexamethasone; IQR, interquartile range; KCRD, carfilzomib, cyclophosphamide, lenalidomide and dexamethasone; NHS, National Health Service; OS, overall survival; PFS, progression-free survival; PFS2, time to second objective disease progression; RCD, lenalidomide, cyclophosphamide and dexamethasone; VCD, bortezomib, cyclophosphamide and dexamethasone.

Source: Jackson *et al*, 2019.⁵



B.2.4 Statistical analysis and definition of study groups in the relevant clinical effectiveness evidence

B.2.4.1 Myeloma XI sample size calculations (ITT population)

The study was powered to detect a difference in PFS and OS for the ITT population and the predefined subpopulation patients who were transplant-eligible (includes patients who were randomized to lenalidomide 25 mg before protocol Version 5.0).⁵

In total, 1971 patients entered the maintenance phase of Myeloma XI.

For the combined analysis across both pathways, 1057 PFS events were required in 1900 patients (based on an overall allocation ratio of ~1.35:1) to demonstrate a 6% increase in 5-year survival over a follow-up period of 4 years, equivalent to a hazard ratio of 0.84 and 80% power. A total of 1416 PFS events were required for 90% power. This assumed a two-sided 5% level of significance, a 2% dropout rate and a 3.25-year recruitment.⁵

Owing to the complex design of the Myeloma XI study, several pre-specified and final analyses were planned. For the maintenance phase, an interim analysis to compare OS between the lenalidomide and observation arms was planned when half of the required events (≥ 229 deaths) had occurred. To ensure an overall significance level of 5% was maintained, the O'Brien and Fleming alpha-spending function was used (interim analysis bound 0.94%, final analysis bound 4.7%).⁵ The bound for the interim analysis was advisory and was presented to the Independent Myeloma XI DMEC and the Independent Myeloma XI Trial Steering Committee on 1

September 2016 following which a decision not to release the interim analysis and to continue the trial was taken.⁵

B.2.4.2 Myeloma XI statistical analysis

Summaries of time to events for the co-primary endpoints, OS and PFS, and PFS2, were analysed using the Kaplan–Meier method. Hazard ratios were calculated using the Cox proportional hazards model, controlling for stratification factors at randomisation and excluding centre.⁵

Reported adverse events were used as a measure of toxicity. Cumulative incidence function curves for time to second primary malignancies were estimated using non-parametric maximum likelihood estimation.⁵

Pre-planned subgroup analyses included an analysis for the sub-cohort of patients eligible for ASCT. Results for this subgroup are presented in section B.2.7. Pre-specified subgroup analyses of PFS and OS were also conducted for the presence or absence of adverse individual cytogenetic abnormalities, cytogenetic risk, pathway (ASCT eligibility) and, induction and intensification status (type of induction and VCD intensification).⁵

Post-hoc exploratory analyses were conducted on PFS, OS and PFS2 by the following factors:

- Sex, age, disease stage according to the International Staging System;
- Response status at the start of maintenance
- Type of induction or intensification (limited to PFS2)
- Cytogenetic risk group (limited to PFS2)
- Subsequent receipt of lenalidomide in later lines of therapy
- A meta-analysis including ASCT-eligible patients in Myeloma XI and those of previously published trials.

Table 14. Summary of statistical analyses used in Myeloma XI

Outcome	Calculated as	Statistical analysis
PFS	<ul style="list-style-type: none"> Time from maintenance randomisation to disease progression (IMWG criteria) or death from any cause A prespecified subgroup analysis for the presence or absence of adverse individual cytogenetic abnormalities, cytogenetic risk, pathway (ASCT eligibility) and, induction and intensification status (type of induction and VCD intensification). A treatment comparison in each subgroup was assessed using a likelihood ratio test for heterogeneity of treatment effect using the same Cox model used in the main analysis with the addition of the subgroup and interaction terms. Subgroup effects were assessed using a test for heterogeneity, with one degree of freedom for two-category subgroups and two degrees of freedom test for the three category subgroups 	<ul style="list-style-type: none"> Survival distribution functions were analysed using the Kaplan–Meier method. PFS with a two-sided 95% CI was estimated Comparisons were made between the allocated groups using a Cox proportional hazards model stratified by the minimization factors excluding centre. Hazard ratios were calculated and presented with 95% CIs An interim analysis was pre-planned; study significance levels were spread over the pre-planned interim analysis and the final analysis by an O’Brien-Fleming alpha spending function Exploratory analyses based on a Cox proportional hazards model were conducted to assess the demographic and prognostic factors that most affected treatment outcome
OS	<ul style="list-style-type: none"> Time from maintenance randomisation to death from any cause or last follow-up. 	<ul style="list-style-type: none"> Survival distribution functions were analysed using the Kaplan–Meier method. Median OS with two-sided 95% CI was estimated Comparisons were made between the allocated groups using Cox proportional hazards model stratified by the minimization factors excluding centre. Hazard ratios were calculated and presented with 95% CIs
PFS2	<ul style="list-style-type: none"> Time from maintenance randomisation to date of second progressive disease, start of third-line therapy or death from any cause, whichever occurred first 	<ul style="list-style-type: none"> Similar methods were used as for the PFS analysis

ASCT, autonomous stem cell transplant; CI, confidence interval; IMWG, International Myeloma Working Group; VCD, bortezomib, cyclophosphamide and dexamethasone;

PFS, progression-free survival; PFS2, second progression-free survival; OS, overall survival.

Source: Jackson *et al*, 2019.⁵

Company evidence submission for post-ASCT maintenance with lenalidomide (ID475)

B.2.4.3 Myeloma XI maintenance participant flow

The Myeloma XI cohort considered for analysis, is presented in Figure 5. Patients in the non-intensive pathway were not considered for this analysis because they had not received ASCT, and therefore do not satisfy the marketing authorization for lenalidomide for the indication relevant to this decision problem. Patients randomized to observation before protocol Version 5.0 were also excluded from the analysis to preserve randomisation of the comparison with lenalidomide 10 mg. Patients who received lenalidomide in combination with vorinostat were also excluded.

Figure 5. Summary of participants included in the Myeloma XI analysis

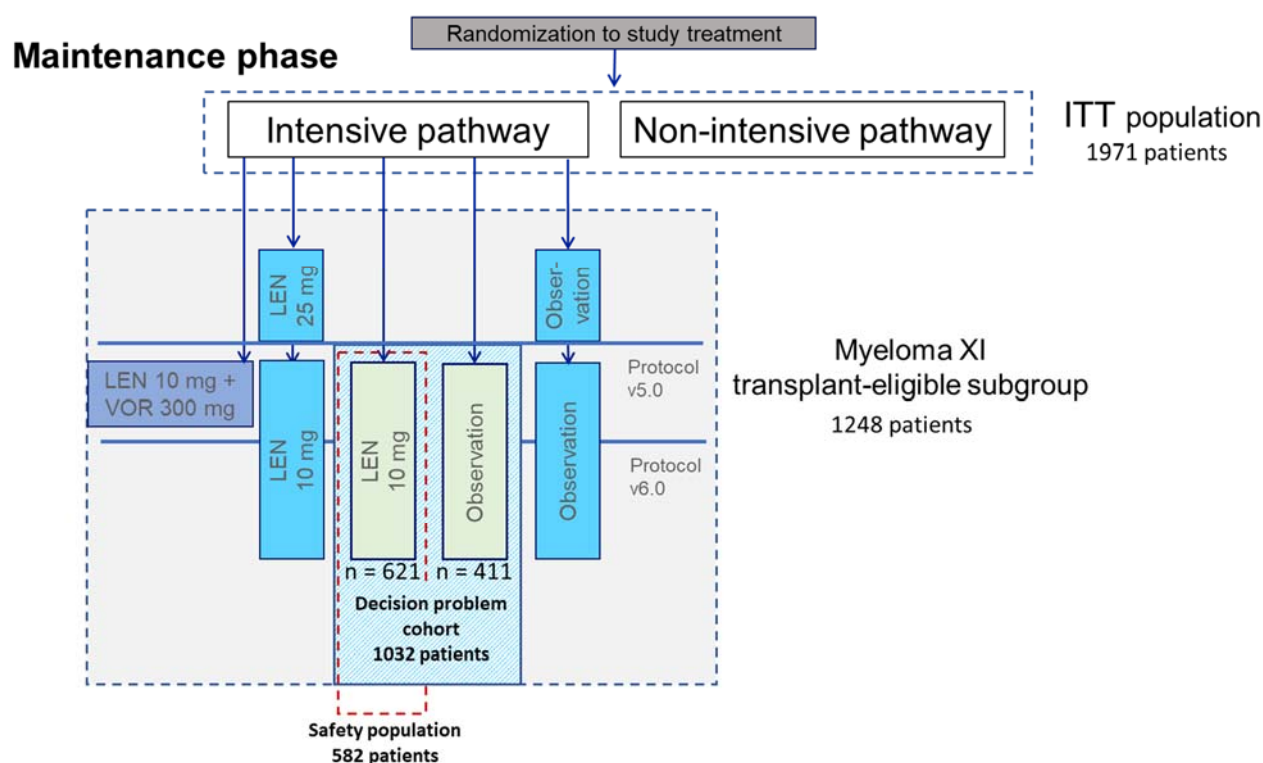

Note: Myeloma XI data used for efficacy analysis (N = 1,032) is shown in light blue box whilst the safety population (N = 582, lenalidomide arm only) is indicated by the dotted red box.

ASCT, autologous stem cell transplant; ITT, intention-to-treat; LEN, lenalidomide; VOR, vorinostat.

Source: Myeloma XI trial patient-level data analysis 2019⁸⁶ and Jackson *et al*, 2019.⁵

In total, 1971 patients were randomized to maintenance therapy between 13 January 2011 and 11 August 2017: 1137 patients to lenalidomide and 834 to observation (Figure 5).⁵ Of these, 1248 patients were included in the Myeloma XI transplant-eligible cohort (includes patients who were randomized to lenalidomide 25 mg or observation before protocol Version 5.0; Figure 5).

Company evidence submission for post-ASCT maintenance with lenalidomide (ID475)

The Myeloma XI data presented, defined by the scope of the decision problem (protocol Version 5.0 onwards), comprised 1032 patients: 621 patients were accrued to the lenalidomide 10 mg arm and 411 accrued to the observation arm (Figure 5).⁸⁶

Appendix D presents the CONSORT image depicting patient flow for Myeloma XI.

B.2.5 Quality assessment of the relevant clinical effectiveness evidence

Full details of quality assessment of Myeloma XI are provided in Appendix D.

B.2.6 Clinical effectiveness results

Efficacy results are presented for the Myeloma XI cohort being considered (n = 1032; Figure 5), which represents efficacy outcomes in a patient population defined by the scope of the decision problem (section B.2.4.3).

B.2.6.1 Summary of clinical data

Key efficacy outcomes are summarised in Table 15.

- Lenalidomide maintenance produced statistically and clinically significantly better outcomes than observation alone in terms of PFS, PFS2 and OS.
 - Improvement in the co-primary endpoint PFS of [REDACTED] compared with observation alone ([REDACTED]).
 - Improvement in the co-primary endpoint OS compared with observation alone ([REDACTED]).

Table 15. [REDACTED]

[REDACTED]	[REDACTED]	[REDACTED]	[REDACTED]
[REDACTED]	[REDACTED]	[REDACTED]	[REDACTED]
[REDACTED]	[REDACTED]	[REDACTED]	[REDACTED]
[REDACTED]	[REDACTED]	[REDACTED]	[REDACTED]

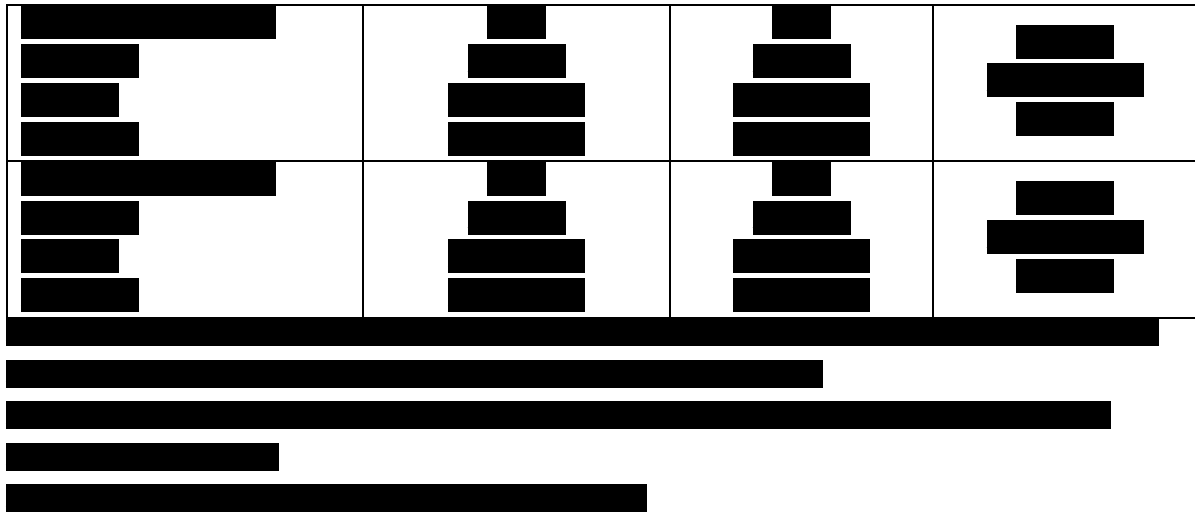

B.2.6.2 Progression-free survival

Analysis of the primary endpoints demonstrated that lenalidomide significantly reduced the risk of disease progression or death by [REDACTED] compared with observation ([REDACTED]).⁸⁶ Progression or death occurred in [REDACTED] patients in the maintenance arm ([REDACTED]) and [REDACTED] patients in the observation arm ([REDACTED]). As shown in Figure 6, the Kaplan–Meier curves separate early and remain well separated over the 60-month time frame. Lenalidomide was associated with an improvement in median PFS compared with observation: [REDACTED] ([REDACTED]; Figure 6). Patients who received lenalidomide 10 mg gained a median of [REDACTED] of time free from progression or death.⁸⁶

Figure 6. [REDACTED]

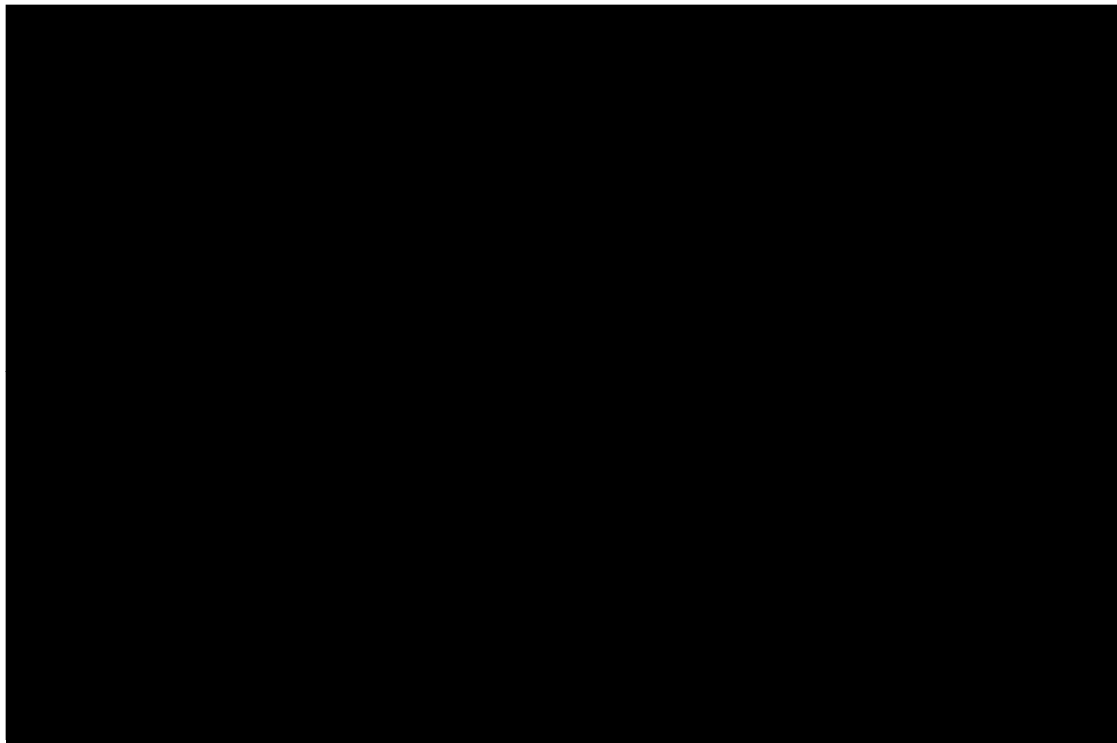

[REDACTED]
[REDACTED]

B.2.6.3 Overall survival

Lenalidomide was associated with a significant reduction of [REDACTED] in risk of death compared with observation ([REDACTED]). Deaths occurred in [REDACTED] [REDACTED] in the maintenance arm compared with [REDACTED] in the observation arm. As shown in Figure 7, the Kaplan–Meier curve for the lenalidomide maintenance arm appears to have stabilised. Median OS [REDACTED] in the maintenance arm and was [REDACTED] in the observation arm ([REDACTED]) at the time of the data cut.⁸⁶

Figure 7. [REDACTED]



[REDACTED]

[REDACTED]

B.2.6.4 Progression-free survival on next-line therapy (PFS2)

No PFS2 were available for the Myeloma XI cohort under consideration. However, data for the Myeloma XI ITT and key ASCT-eligible subgroup analysis are presented in Appendix D and M9.

B.2.7 Subgroup analysis

Prespecified subgroup PFS and OS analyses of the overall Myeloma XI trial ITT population are presented in Appendix E.

B.2.8 Meta-analysis

A meta-analysis was performed by the Myeloma XI study authors using Myeloma XI,⁵ CALGB 100104, IFM 2005-02 and GIMEMA, which was consistent with the findings of an older analysis (CALGB 100104, IFM 2005-02 and GIMEMA),⁸⁴ no meta-analysis was performed for this submission.

Transitivity issues between CALGB 100104, IFM 2005-02, GIMEMA and Myeloma XI with respect to the lenalidomide dosing regimen and use of lenalidomide as induction therapy, mean that any meta-analysis between these trials would be subject to a large subject to a high degree of heterogeneity, particularly with respect to OS.⁹¹

Thus, it was deemed inappropriate to conduct a meta-analysis of these studies, using the Myeloma XI data in this submission, either for clinical arguments or for use by the economic model.

B.2.9 Indirect and mixed treatment comparisons

No indirect or mixed treatment comparison was performed.

B.2.10 Adverse events

Safety and tolerability data are based on patients who received at least one dose of study drug. No safety data was available for the observation arm.

Safety data for the Myeloma XI ITT population are presented in Appendix F.

B.2.10.1 Most frequently reported adverse events

A total of [REDACTED] patients received at least one dose of lenalidomide maintenance therapy. Grade 1 or 2 adverse events reported by at least 10% of patients who received lenalidomide maintenance therapy, and grade 3 or 4 adverse events reported by at least 1% of patients (and all grade 5) are given in Table 16.

The pattern, incidence and severity of AEs was similar between the Myeloma XI cohort presented and the Myeloma XI ITT population (Appendix F).

Table 16. [REDACTED]

[REDACTED]	[REDACTED]	[REDACTED]	[REDACTED]	[REDACTED]
[REDACTED]	[REDACTED]	[REDACTED]	[REDACTED]	[REDACTED]
[REDACTED]	[REDACTED]	[REDACTED]	[REDACTED]	[REDACTED]

B.2.10.2 Serious adverse events

A complete list of serious adverse events (SAEs) is given for the Myeloma ITT population in Appendix F. At least one SAE was reported by 45% of patients in the lenalidomide arm and 17% in the observation arm; infections were the most frequently reported SAE in both treatment arms.⁵ No deaths occurred that were reported as related to treatment with lenalidomide.⁵

B.2.10.3 Second primary malignancies

A complete list of all secondary primary malignancies recorded in Myeloma XI is provided in Appendix F. The 3-year cumulative incidence of second primary malignancies (SPMs) was low, but higher in the lenalidomide arm than the observation arm (5.3% [95% CI 3.6–7.1%] vs 3.1% [1.8–4.5%]); HR 1.85 [95% CI 1.18–2.90]). The overall incidence of SPMs per 100 patient-years was 2.4 (95% CI 1.9–3.1) in the lenalidomide group and 1.4 (1.0–2.0) in the observation group. The 3-year cumulative incidence of deaths related to SPMs was also low in both groups (2.0% [95% CI 0.9–3.1%] in the lenalidomide group vs 0.9% [0.2–1.6%] in the observation arm).⁵

B.2.11 Ongoing studies

The Myeloma XI trial is ongoing with the final analysis expected in 2022.

B.2.12 Innovation

Lenalidomide represents a step-change in the management of transplant-eligible NDMM. It has the following innovative characteristics, which are meaningful to both patients and the NHS:

- Lenalidomide prolongs remission after ASCT in patients with newly diagnosed MM,⁵ which is a key treatment aim of MM.⁴⁷
- As an oral-based agent, lenalidomide is suitable for maintenance treatment via an administrative route that is generally preferred by patients.^{92,93}

Prolonging remission, especially in the first remission period where patients are likely to experience better HRQoL, is a treatment aim in MM and a key factor in patient survival.^{26,43} As MM follows a characteristic remission–relapse cycle²⁴ owing to the persistence or emergence of very low levels of clonal plasma cells known as minimal

residual disease,²⁹ patients can experience a relapse post-transplantation despite achieving a complete response to ASCT.^{27,29} Patients who are eligible for transplant tend to be younger, fitter, and stand to lose up to 30-years of life expectancy compared with normal mortality expectations,⁹⁴ and therefore represent a population who could benefit substantially from lenalidomide maintenance therapy. Continuous suppression of residual disease through the use of an immunomodulatory therapy, can improve outcomes in patients with MM, as demonstrated by Myeloma XI.^{5,66-68}

Myeloma XI is the only UK-based RCT of lenalidomide maintenance study conducted to date and follows UK-related dosing schedules, treatment intensity and duration of treatment specific to UK clinical practice.⁵ Lenalidomide maintenance therapy led to a statistically significant and clinically meaningful prolongation of PFS and OS in patients with MM post-ASCT compared with observation alone.⁸⁶ These important clinical benefits are therefore expected to translate to patients who will receive lenalidomide maintenance therapy in UK clinical practice should this treatment be reimbursed.

There is generally a strong preference by patients for oral-based treatments over other routes of administration.^{92,93} Lenalidomide, as an oral therapy, is convenient for continuous daily administration at home, which is unlikely to incur the lifestyle and cost implications associated with more invasive routes of administration.

Furthermore, treatment at home may offer patients a sense of control over their treatment with less interference in their daily lives including work, family and social activities resulting in an improved quality of life compared with hospital-based treatment.⁹³

B.2.13 Interpretation of clinical effectiveness and safety evidence

Although ASCT is the standard of care for transplant eligible patients with newly diagnosed MM, it is not curative and most patients relapse within ~2.5 years (median PFS range: 21.6–28.9 months).^{3,4,34} The typical pattern of relapse and remission (Figure 1) suggest that continuous anti-myeloma therapy is required to suppress residual disease, maximise depth of response and prolong the first

remission; a key factor in maintaining a patient's quality of life and ultimately extending their survival.^{24,27,28}

Lenalidomide is the only EMA-approved drug in the post-ASCT maintenance setting and has a known and manageable toxicity profile when used continuously.⁹ Consequently, lenalidomide maintenance is recommended by most contemporary MM guidelines recognised by clinicians in the UK.^{50,74,75,81}

Patients who received lenalidomide maintenance post-ASCT achieve a longer PFS and OS than those who do not receive treatment, as demonstrated by the Myeloma XI trial, which provides the primary clinical data supporting this submission.

B.2.13.1 Efficacy and safety profile

Lenalidomide maintenance provides a statistically significant and clinically meaningful increase in PFS in transplant eligible patients compared with observation

Compared with observation, lenalidomide maintenance post-ASCT was associated with a statistically significant increase in PFS of 26.2 months compared with observation.⁸⁶ This increase, representing an approximate doubling in median PFS and a 54% reduction in the risk of disease progression (HR 0.46, 95% CI, 0.37–0.58), can also be considered clinically meaningful as this represents a direct extension to the patient's first remission.

Lenalidomide maintenance was associated with a statistically significant survival benefit in patients who were transplant eligible

OS is still considered a gold standard in demonstrating clinical efficacy in oncology,⁹⁵ being an unambiguous endpoint that is insensitive to investigator interpretation and directly reflects clinical benefit to patients. Patients treated with lenalidomide maintenance had a significant survival advantage over observation (HR, 0.61; 95% CI, 0.42–0.87).⁸⁶

Although the precise median OS advantage in months is yet to be determined (median OS not reached for lenalidomide arm vs 61.7 months observation), this

improvement is clinically meaningful (especially given the length of follow up) on the basis that the Kaplan–Meier curve for the lenalidomide arm has appeared to have stabilised and it may be some time before the median is reached.

Lenalidomide has an acceptable and manageable adverse event profile for maintenance treatment

The safety profile for lenalidomide as maintenance therapy was consistent with the known safety profile for lenalidomide.^{1-4,26} Whilst lenalidomide maintenance therapy is associated with an increased risk of adverse events compared with observation, this is likely to be offset by the clear efficacy benefits gained by receiving an active maintenance treatment.

As expected given the known adverse event profile of lenalidomide, haematological events (neutropenia, thrombocytopenia and anaemia) were the most frequently reported grade 3 and 4 adverse events. Algorithms are available in the Summary of Product Characteristics to assist with the management of neutropenia and thrombocytopenia (Appendix C).⁹

The incidence of grade 3 and 4 peripheral neuropathy was low (0.2%), which is an important consideration for a long-term treatment such as maintenance therapy. The risk of SPMs was increased in patients treated with lenalidomide compared with observation, but the 3-year cumulative incidence of SPMs remained low in both treatment groups.⁵ Furthermore, clinicians have had over 10 years of experience managing lenalidomide treatment in patients with MM⁷ coupled with that gained from Myeloma XI.⁵

B.2.13.1 Context, strengths and limitation of the evidence base

Strengths

Myeloma XI is the largest RCT to date that has studied the effect of lenalidomide maintenance therapy in MM patients post-ASCT.⁵ Myeloma XI is composed exclusively of UK patients recruited from 110 NHS centres throughout the UK. The trial's study design is aligned with UK clinical practice and will form the basis of UK clinical practice should this indication be reimbursed for use in the NHS.

Myeloma XI is the first RCT in this maintenance indication that was powered for OS as a primary endpoint with no treatment-switching permitted. This helps remove previous ambiguity surrounding the impact of lenalidomide maintenance on patients' OS that led to some regulatory bodies resorting to a meta-analysis.⁸⁴ Furthermore, as the Myeloma XI was based in the UK, subsequent therapies used post-progression in the trial should also reflect UK clinical practice.

The effect of post-ASCT maintenance with lenalidomide is in line with data from other non-UK based trials that assessed the efficacy of lenalidomide as post-ASCT maintenance therapy (Table 17),^{2-4,34} when taking into account study design differences. Myeloma XI also demonstrated a similar adverse event profile for lenalidomide to that observed in other trials that have assessed its safety in the maintenance setting (Table 17).^{2-4,34,96}

Table 17. Comparative summary of key efficacy and safety outcomes in CALGB 100104, GIMEMA, IFM 2005-02 and Myeloma XI

Trial, country	Intervention vs comparator	Primary endpoint	Key secondary endpoint	Grade 3/4 AEs in lenalidomide arm, %
CALGB 100104 ⁴ USA N = 460	Lenalidomide vs placebo	<i>Median TTP,^a months</i> 46 vs 27 HR 0.48 (95% CI: 0.36–0.63; <i>p</i> < 0.001	<i>OS events,</i> 15% vs 23% <i>p</i> = 0.03	<i>Anaemia, 4.8</i> <i>Neutropenia, 15.5</i> <i>Thrombocytopenia, 6.9</i>
GIMEMA ³⁴ Italy and Israel N = 273	Lenalidomide vs placebo	<i>Median PFS, months</i> 41.9 vs 21.6 HR 0.47 (95% CI, 0.33–0.65; <i>p</i> < 0.001)	<i>HR for death 0.64</i> (95% CI: 0.36–1.15; <i>p</i> = 0.14)	<i>Anaemia, 1.7</i> <i>Neutropenia, 23.3</i> <i>Thrombocytopenia, 4.3</i>
IFM 2005-02 ³ France, Belgium and Switzerland N = 614	Lenalidomide vs placebo	<i>Median PFS, months</i> 41 vs 23 HR, 0.50 (95% CIs not reported; <i>p</i> < 0.001) ^b	<i>OS events, %</i> 26 vs 24; HR: 1.06 (95% CI not reported; <i>p</i> = 0.70) ^c	<i>Anaemia, 3</i> <i>Neutropenia, 51</i> <i>Thrombocytopenia, 14</i>
Myeloma XI UK [REDACTED]	Lenalidomide vs placebo	<i>Median PFS (95 % CI), months</i>		[REDACTED] [REDACTED] [REDACTED] [REDACTED]

--	--	--	--	--

^a Defined as time to progressive disease or death from any cause after transplantation. This definition aligns with the definition of PFS provided by both the IMWG⁹⁰ and FDA.⁹⁷ IMWG define TTP as ‘Duration from start of treatment to disease progression, with deaths from causes other than progression censored.’ FDA give a variation of TTP as follows ‘TTP is defined as the time from randomisation until objective tumor progression; TTP does not include deaths.’

^b July 2010 data cut-off

^c October 2011 data cut-off

AE, adverse event; CI, confidence interval; FDA, Food and Drug Administration; HR, hazard ratio; IMWG, International Myeloma Working Group; NA, not applicable; NR, not reached; OS, overall survival; PFS, progression-free survival; TTP, time to progression.

Limitations

The Myeloma XI ITT population comprised patients who were transplant-eligible and -ineligible, and following a series of protocol amendments, the dose in the lenalidomide arm was reduced from 25 mg to 10 mg meaning that a proportion of patients who received lenalidomide maintenance had initially received a higher dose of study treatment.⁵ This was addressed by the analysis conducted by Celgene that compared clinical outcomes in patients who were transplant-eligible and received lenalidomide 10 mg only as maintenance (Table 7),⁸⁶ and therefore represent the patient population specified in the decision problem. The results of this analysis are consistent with those for the transplant-eligible subgroup (Appendix D and E) as well as those from other trials (Table 17).^{2-5,34,86}

Myeloma XI was an open label trial, but data analysis was blinded; however, that of the Myeloma XI data analysis presented in B2.6 was not.

Myeloma XI has yet to report all its planned endpoints and subgroup analyses (e.g. response rates, primary endpoint subgroups analyses for high risk cytogenetics etc.).

However, these are unlikely to significantly impact on the clinical data used and outcomes reported in this submission.

Myeloma XI protocol amendments may have impacted power calculations of selected comparisons, although the statistical significance was reached on the primary endpoints demonstrating the robustness of the study to design amendments.

B.2.13.2 Life-expectancy

Although lenalidomide offers an extension to life compared to current NHS treatment options (observation), it does not qualify as a 'life-extending treatment at the end of life', Table 18.

Table 18. End-of-life criteria

Criterion	Data available	Reference in submission (section and page number)
The treatment is indicated for patients with a short life expectancy, normally less than 24 months	Median survival in the comparator arm was [REDACTED]	N/A
There is sufficient evidence to indicate that the treatment offers an extension to life, normally of at least an additional 3 months, compared with current NHS treatment	[REDACTED]	Section B.2.6

N/A, not applicable; NHS, National Health Service.

B.3 Cost effectiveness

B.3.1 *Published cost-effectiveness studies*

Systematic searching identified four cost-effectiveness evaluations⁹⁸⁻¹⁰² of maintenance treatment in patients with newly diagnosed MM who are undergoing or eligible for ASCT. No studies identified were evaluated from the UK payer perspective. A summary of the identified published cost-effectiveness analyses is presented in Table 19. Details of the methods used to identify these studies are presented in Appendix G.

Each of the four studies identified used portioned survival models and publically available trial data (CALGB 100101, GIMEMA and IFM 2005-02) to estimate the cost-effectiveness of maintenance compared with no maintenance in patients with newly diagnosed MM in the pre-progression, post-progression and death health states. Zhou *et al*, 2018¹⁰⁰ also compared bortezomib maintenance vs no maintenance and the analysis presented to PBAC¹⁰¹ compared thalidomide maintenance with observation. Neither of these analyses were considered relevant to this review as bortezomib and thalidomide are not licensed by the EMA for use in the UK clinical setting.

Published cost-effectiveness analyses reported diverse estimates of cost per QALY for maintenance with lenalidomide (Table 19). Cost-effectiveness ratio ranged between €31 000 per QALY⁹⁹, which is considered cost-effective, to €277 500⁹⁸, which is considered not cost-effective.

The variation in ICERs was driven by the clinical study underpinning the analysis (CALGB 100101 was the main source), using the list price for lenalidomide, the duration of model time horizon and the mix of therapies used in subsequent treatment lines in the model. For example, the study by Olry de Labry Lima *et al*, 2019⁹⁸ used sensitivity analysis to show that [REDACTED]

[REDACTED] The model time horizon was also an important driver of cost-effectiveness, as discussed in Dhanasiri *et al*.¹⁰³

Table 19. Summary of results of identified published cost-effectiveness analyses

Study	Model time-horizon	QALYs			Costs				ICER (cost/QALY)
		Maintenance	Comparator	Incremental		Maintenance	Comparator	Incremental	
Olry de Labry Lima, ^a 2019 ⁹⁸	10 years	CALGB 100101, 5.72	4.61	1.11	With CALGB 100101	€836 534	€528 964	€307 570	€277 457
		IFM 2005-02, 5.13	4.98	0.15	Total costs				
					Of which:	€ 826 434.58	€525 283.96:	€301 151	
					Total drug costs	(98.3%):	0	€535 435	
					Maintenance	€535 407.03	€303 957.26	–€173 303	
					First line	€130 354	€221 326.70	–€60 654	
					Second line	€160 673.56			
					AEs	€6487.91			
					Second primary cancers	(1.07%) €3611.82			
						(0.6%)			
					Probabilistic sensitivity analysis		€528 964	€260 625	€235 107
					With CALGB 100101	€789 589	€600 229	€229 690	€1 502 781
					With IFM 2005-02	€829 919			
Uyl de Groot, 2018 ⁹⁹	Lifetime	8.05	4.79	2.26	Total costs	€386 559	€315 023	€71 536	Deterministic, €31 695
					Maintenance (with HCRU)	€156 760	€18 519	€138 241	Probabilistic, €31 328
					Subsequent therapies	€159 540	€245 834	–€86 294	
						€56 941	€38 371	€18 571	

Company evidence submission for post-ASCT maintenance with lenalidomide (ID475)

					Future HC and productivity costs				
Zhou, 2018 ¹⁰⁰	Lifetime	N/A	N/A	2.99		N/A	N/A	US\$476,690	US\$159,240
PBAC, 2018 ¹⁰¹	25 years	6.52	4.08	2.44		Redacted	Redacted	Redacted	Redacted

^aBase case values reported for a time horizon of 120 months

AE, adverse event; HC, healthcare; HCRU, healthcare resource use; ICER, incremental cost-effectiveness ratio; N/A, not applicable; QALY, quality-adjusted life year; US\$, US dollar.

In summary, existing economic evaluations may be of limited use in the assessment of the cost-effectiveness of lenalidomide in the UK setting:

- A major limitation is in the evidence base considered in these analyses, comprising studies that do not fit the NICE decision problem. This is because the IFM 2005-02, CALGB 100101 and GIMEMA studies introduce potential biases with respect to treatment dose, patient switches to the observation arm, mixed ASCT and non-ASCT eligible populations and the use of consolidation therapy (section B.2.1). The PBAC submission⁹¹ also concluded that a meta-analysis of maintenance trials was to be treated with caution given the heterogeneity across trials.
- The use of subsequent therapies in these models is not in line with NICE recommendations and treatments available after first progression
- The limited comparability of costs and drug prices across these models would also suggest that the ICERs obtained from these studies are not applicable to the NICE decision problem.

B.3.2 Economic analysis

A *de novo* economic evaluation was developed to estimate the cost-effectiveness of lenalidomide as monotherapy for the maintenance treatment of adults with newly diagnosed MM who have undergone autologous stem cell transplantation. The resulting economic model is structurally similar to existing models of lenalidomide in other patient populations and is consistent with published economic evaluations in MM.^{80,104-107}

The perspective for the cost-effectiveness analysis is that of the NHS and personal social services (PSS), with costs and outcomes discounted at 3.5%, as per the NICE reference case.¹⁰⁸

B.3.2.1 Patient population

In line with the marketing authorisation and final NICE scope, the economic evaluation considered lenalidomide monotherapy (10 mg on days 1–21 of a 28-day cycle) maintenance treatment of adult patients with newly diagnosed MM who have undergone an ASCT.

The data used in this economic evaluation is taken from the analysis of Myeloma XI, as defined in Table 7, section B.2.⁸⁶

The dosage in Myeloma XI was considered to be reflective of UK clinical practice, compared with doses used in the EMA registration studies (CALGB 100104 and IFM 2005-02);^{2,3} and other studies of maintenance such as GIMEMA,³⁴ as detailed in section B.2.2.

B.3.2.2 Model structure

The economic model is a partitioned survival analysis (PartSA) model comprised of three health states (pre-progression, progressive disease, and death; Figure 8). State membership is defined by a set of non-mutually exclusive survival curves.¹⁰⁹ The OS curve is used to estimate the proportion of patients alive over time; the area under the extrapolated OS curve provides an estimate of mean life expectancy. A PFS curve is further used to define how many of these alive patients remain pre-progression at each time point: the area under the extrapolated PFS curve provides an estimate of mean time spent pre-progression. As such, the model does not use transition probabilities that describe transitions from one health state to the next. Partitioned survival models are common in cost-effectiveness analyses in oncology, and have been used in previous technology appraisals in MM.^{80,104-107}

Parametric survival models were used to calculate the area under the curve (AUC) for each outcome and to extrapolate Myeloma XI outcomes beyond the trial period. The model used time intervals of 28 days, reflecting the duration of one therapy cycle.

Health state membership is illustrated in Figure 8. In this analysis, time spent in each health state at a given time point is defined as:

- Pre-progression = PFS
- Progressive disease = OS – PFS
- Death = 1 – OS.

In addition to OS and PFS, a time-to-discontinuation (TTD) curve for lenalidomide was also estimated and used to define the proportion of patients who remained on treatment over time.

Figure 8. Determining state membership

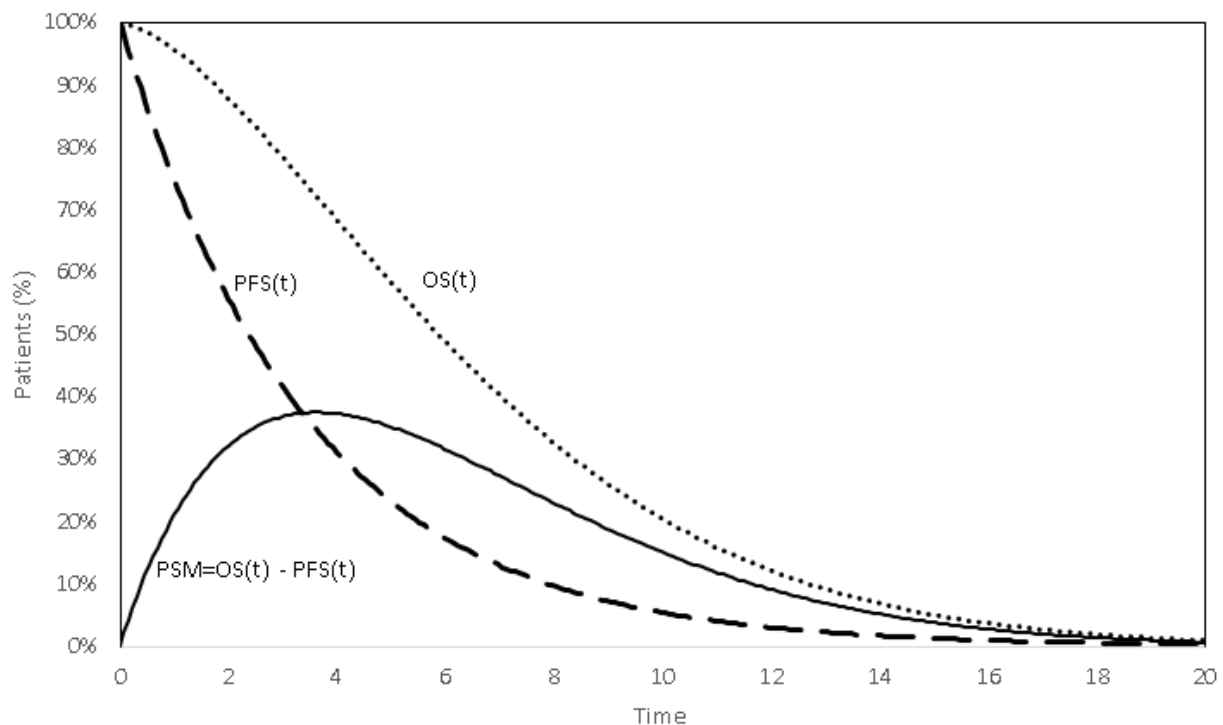

Key: OS, overall survival; PFS, progression-free survival; PSM, progressive disease state membership; t, time; TSD, technical source document.

Source: Adapted from TSD 19.¹¹⁰

Upon disease progression, patients are assumed to experience poorer quality of life (Section B.3.4) and to incur the costs of subsequent therapies used after first and second relapse (Section B.3.4.4), and higher medical resource use (and associated costs; Section B.3.4.2).

Outcomes, but not treatment costs, were adjusted with half-cycle correction, implemented using the life-table method.^b

The model adopted a lifetime time horizon, in accordance with the NICE reference case¹⁰⁸ and previous economic evaluations in MM.^{77,80,104,107}

An overview of the key economic analysis features is provided in Table 20.

^b The time in a given cycle is estimated by taking the average of the number of people at the start and end of the cycle.

Table 20. Features of the economic analysis

Factor	Current appraisal	
	Chosen values	Justification
Time horizon	Lifetime (40 years)	A lifetime time horizon complies with the NICE reference case and is consistent with previous economic evaluations in MM used in NICE technology appraisals. ^{77,80,104,107} The time horizon is sufficiently long to capture the remaining lifespan for the cohort in the model (starting at age 66)
Discount rates	3.5% (costs and outcomes)	Consistent with NICE reference case
Source of effectiveness data	Myeloma XI, as defined in Table 7, section B.2. ⁸⁶	See section B.2 Head to head comparison of maintenance vs. observation in the UK population, adhering to the criteria set by the decision problem.
Assumptions surrounding treatment effect	Independent statistical models were used for lenalidomide and observation in OS and joint models were used for PFS. All models were estimated from Myeloma XI data.	Comparison to longer-term follow-up from CALGB 100104 suggested alternative distributions for each model arm were more appropriate than constraining both model arms to follow the same distribution
Source of utilities	Acaster et al ¹¹¹	Acaster et al ¹¹¹ collected EQ-5D-3L in UK patients at different stages of the disease, allowing population of the model health states with data consistent with the reference case
Source of subsequent therapy data	Provided by survey of UK clinical experts	Reflective of UK clinical practice and NICE funding decisions.
Source of costs	Table 1 eMIT, MIMS, NHS reference costs	Consistent with NICE reference case
Year of costs	2020	Cost data was based on the most recently available, and uplifted where required using the most current inflation indices in the PSSRU.

ASCT, autologous stem cell transplant; EQ-5D-3L, EuroQol – 5 dimensions, 3-level version; MM, multiple myeloma; NHS, National Health Service; NICE National Institute for Health and Care Excellence; OS, overall survival; Personal Social Services Research Unit; PFS, progression-free survival.

B.3.2.3 Intervention technology and comparators

B.3.2.3.1 Intervention

Lenalidomide as monotherapy is the only therapy indicated for the maintenance treatment of adult patients with newly diagnosed MM who have undergone ASCT. Maintenance begins after haematological recovery, at approximately 100 days after ASCT, in people who have not experienced progression as detailed in section B.2 (see also Appendix M).⁵

The recommended starting dose of lenalidomide monotherapy is 10 mg orally once daily (OD) continuously on days 1–21 of a 28-day cycle, until disease progression or intolerance. After three cycles of lenalidomide maintenance, the dose can be increased to 15 mg OD if tolerated, however in UK clinical practice, it is expected that most patients will not require dose escalation and will remain on 10 mg OD (section B.2.3.4). The dose of 10 mg OD used in Myeloma XI is therefore considered reflective of UK clinical practice.

No alternative maintenance treatment is licensed or routinely used within the NHS. The comparator for this economic evaluation is established clinical management without lenalidomide maintenance therapy (referred to hereafter as observation), as represented by the observation arm of the intensive pathway of Myeloma XI.

B.3.2.3.2 Comparator

All analyses that follow are based on Myeloma XI (Table 7), based on the latest data cut available from Myeloma XI (23 October 2017). Analyses were performed in R using the ‘survival’ package and Kaplan–Meier plots were produced using ‘survminer’ package.¹¹²⁻¹¹⁴

B.3.2.4 Clinical parameters and variables

Analyses of PFS (section B.3.2.5), OS (section B.3.2.5.2) and time on treatment (section B.3.2.6) are based on the latest data cut from Myeloma XI presented in section B.2., Table 7. Although the follow-up of Myeloma XI was considerable for an oncology medicine, the trial is still ongoing; therefore, OS and PFS distributions were estimated to inform a life-time horizon in the model.

The most appropriate parametric distributions were based on both internal validity (log-hazard plots, Q-Q plots, goodness of fit to the observed data using AIC and BIC) and external validity (clinical plausibility of the extrapolations), using the process outlined in NICE decision support unit (DSU) technical support document (TSD) 14.¹¹⁵

Clinical plausibility of the extrapolations was assessed comparing son against the RPSFTM adjusted PFS and OS from the CALGB 100104 trial^{2,4} (Appendix O).

The CALGB 100104 study was used because it provides 10.5 years maximum follow-up, an additional [REDACTED] compared to Myeloma XI.

In the comparator arm, the Kaplan–Meier curves for PFS and OS from CALGB 100104 and Myeloma XI overlap for the total follow-up of Myeloma XI, suggesting that the study populations are similar and therefore the extended follow-up from CALGB 100104 is appropriate for validating Myeloma XI extrapolations for both endpoints.

For the lenalidomide arm, the dosing regimen differed between CALGB 100104 (28/28 days) and Myeloma XI (21/28 days). However, the Kaplan–Meier curves for PFS and OS from CALGB 100104 and Myeloma XI, again, were broadly similar, therefore despite the difference in dosing regimen, the CALGB 100101 data were deemed appropriate for longer term validation.

Table 21: Criteria considered for determining the most suitable parametric survival models

Criteria	Method	Description
Observed data	Goodness of fit statistics (AIC and BIC) ^{116,117}	Compare the relative goodness of fit for each of the parametric models while penalizing more complex models (more highly penalised by BIC) ¹¹⁷
	Visual inspection	Parametric survival curves overlaid on the KM to assess how closely the parametric curves match to the observed KM
Extrapolation	External data – CALGB 100101	Fitted parametric survival curves overlaid to actual KM from CALGB 100101 to assess plausibility of extrapolation over the longer term.

Abbreviations: AIC, Akaike information criterion; BIC, Bayesian information criterion; KM, Kaplan–Meier.

B.3.2.5 Estimation of parametric distributions for OS and PFS

To establish which parametric distributions could be considered for these endpoints, the PH / AFT assumptions were tested.

The log-cumulative hazard plots for PFS (Figure 9A) and OS (Figure 10A) show that the proportional hazard assumption may be appropriate as the maintenance and observation curves are parallel throughout the follow-up for both endpoints. The quantile-quantile plots (Figure 9B and Figure 10B) show that accelerated failure time models are also appropriate as the line is approximately straight. Both PH (exponential, Gompertz, Weibull) and AFT (generalised gamma, log-logistic, lognormal) distributions were fitted for OS and PFS (Appendix N).

Both joint models (estimating the hazard ratio/acceleration effect using treatment as a covariate) and independent (estimating curves separately for treatment and comparator) models were fitted. Whilst the first approach implies that the relative effect of maintenance is invariant over time, the second assumption estimates no explicit treatment effect over time, therefore not relying on the PH and AFT assumption holding.

Figure 9 Log-cumulative hazard plot (A) and quantile-quantile plot (B) for PFS

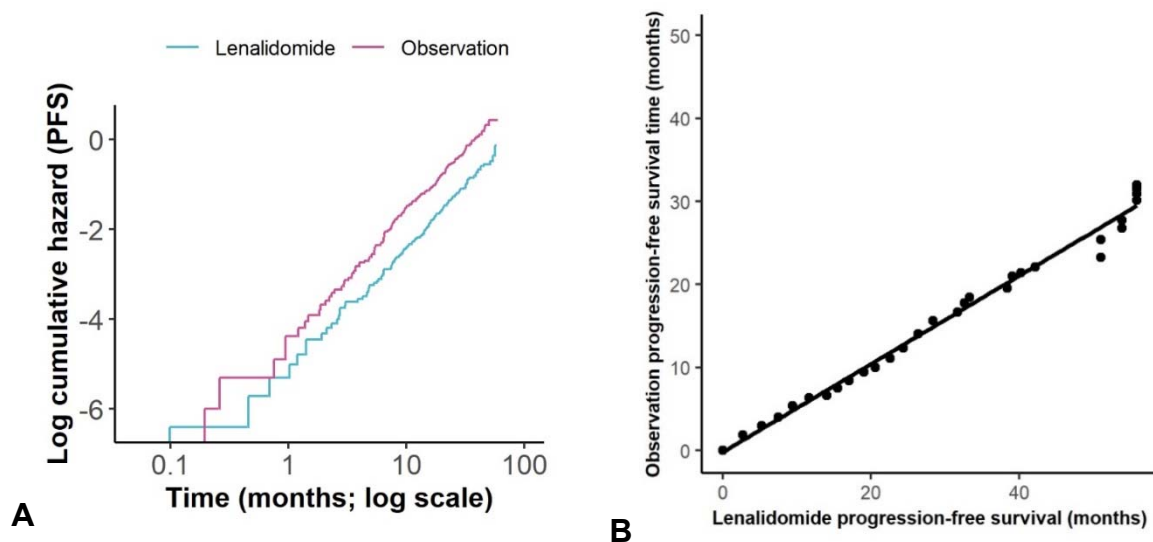

Abbreviations: PFS, progression-free survival.

Figure 10 Log-cumulative hazard plot (A) and quantile-quantile plot (B) for OS

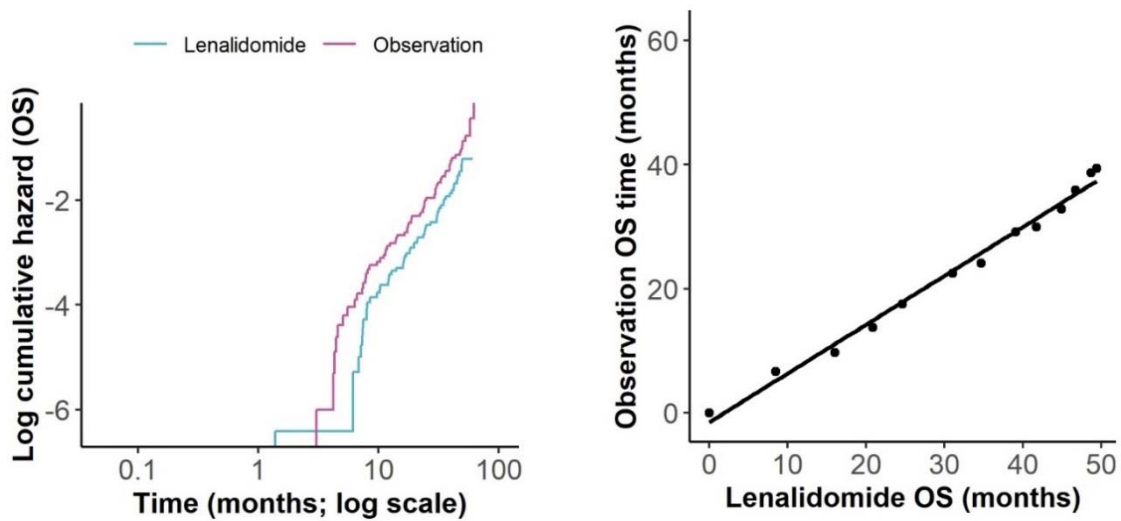

PFS, progression-free survival.

As the log-cumulative hazard plot and the QQ plots are not sufficient to choose between PH or AFT, joint or independent models were both estimated and visual inspection and CALGB 100101 Kaplan–Meier plots were used to conclude on the appropriateness of each approach. When joint modelling generated plausible curves, the independent model was not pursued further.

B.3.2.5.1 PFS distribution selection

Table 22 below reports AIC and BIC statistics for PFS, for both joint and independent models. These statistics are similar for most distributions except for the log-normal which appears a poor fit to Myeloma XI trial data.

Table 22: Parametric survival curves for PFS – goodness of fit statistics

Model	Lenalidomide (independent)				Observation (Independent)				Joint model†			
	AIC	AIC rank	BIC	BIC rank	AIC	AIC rank	BIC	BIC rank	AIC	AIC rank	BIC	BIC rank
Weibull	2546	1	2555	1	2970	1	2978	1	5514	1	5528	1
Log-log	2547	2	2556	3	2972	3	2980	2	5519	3	5533	2
Gompertz	2548	3	2557	4	2973	4	2981	3	5519	4	5534	3
Generalised gamma	2548	4	2561	5	2971	2	2983	5	5516	2	5535	4
Exponential	2551	5	2555	2	2978	5	2982	4	5529	5	5538	5
Log-normal	2559	6	2567	6	2983	6	2991	6	5545	6	5560	6

Abbreviations: AIC, Akaike information criterion; BIC, Bayesian information criterion; PFS, progression-free survival.

Visual inspection (Figure 11) indicates that joint models fit the lenalidomide and observation arms reasonably well. For observation, the Weibull, generalised gamma^c, log-logistic and Gompertz appear to reasonably fit the Myeloma XI Kaplan-Meier curve; for lenalidomide, no model appears incompatible with the Myeloma XI Kaplan–Meier.

^c The Weibull and generalise gamma overlap, as the generalized gamma Q parameter was estimates as 0.96, very close to 1, where the generalised gamma model reduces to a Weibull when Q = 1

Figure 11.

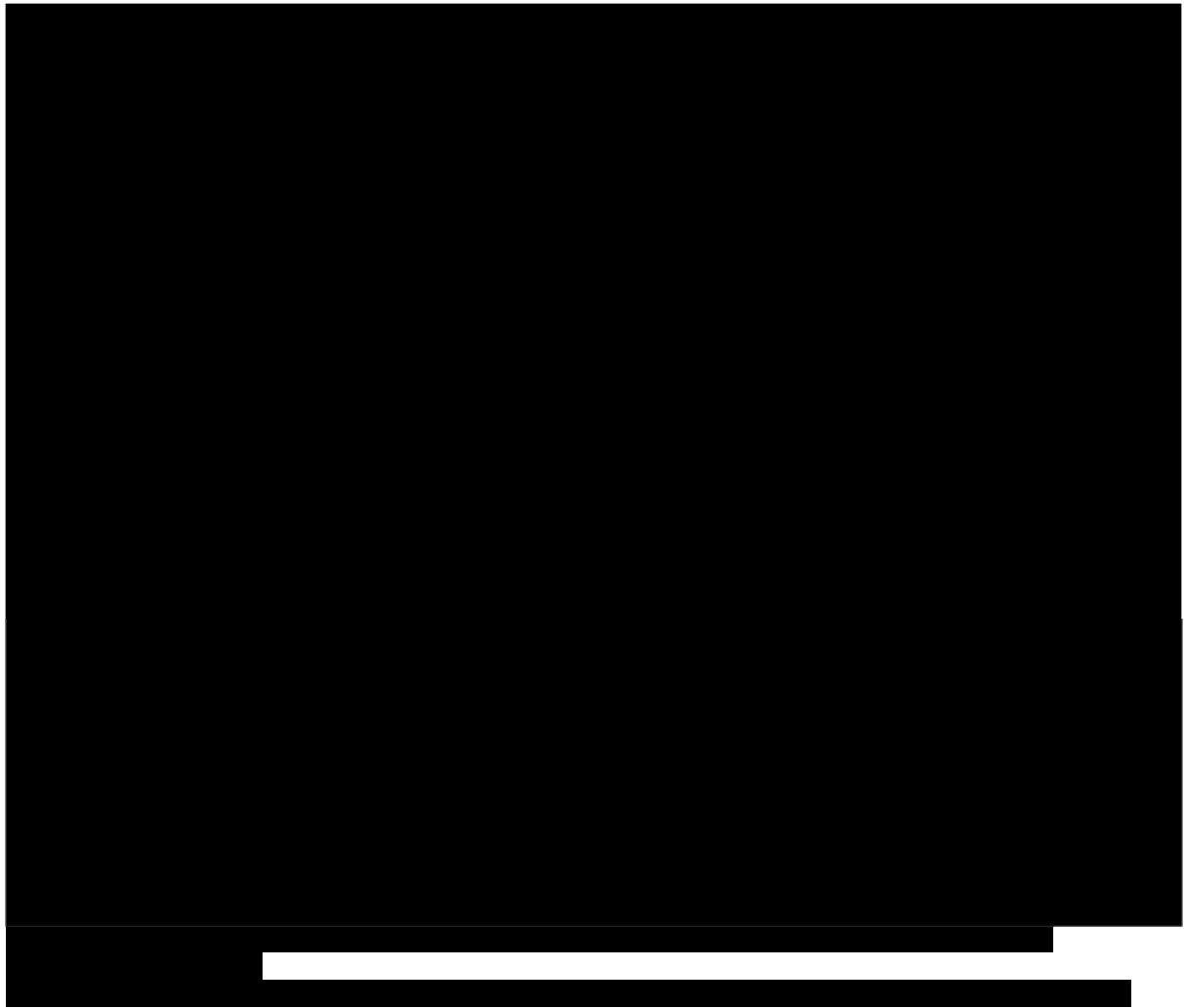

CALGB 100101 validation

The Kaplan–Meier plot of PFS in CALGB 100101 and Myeloma XI shows consistency between the two studies (Figure 12). PFS with observation in CALGB 100101 closely fits that in Myeloma XI, for both observation and lenalidomide.

Figure 12

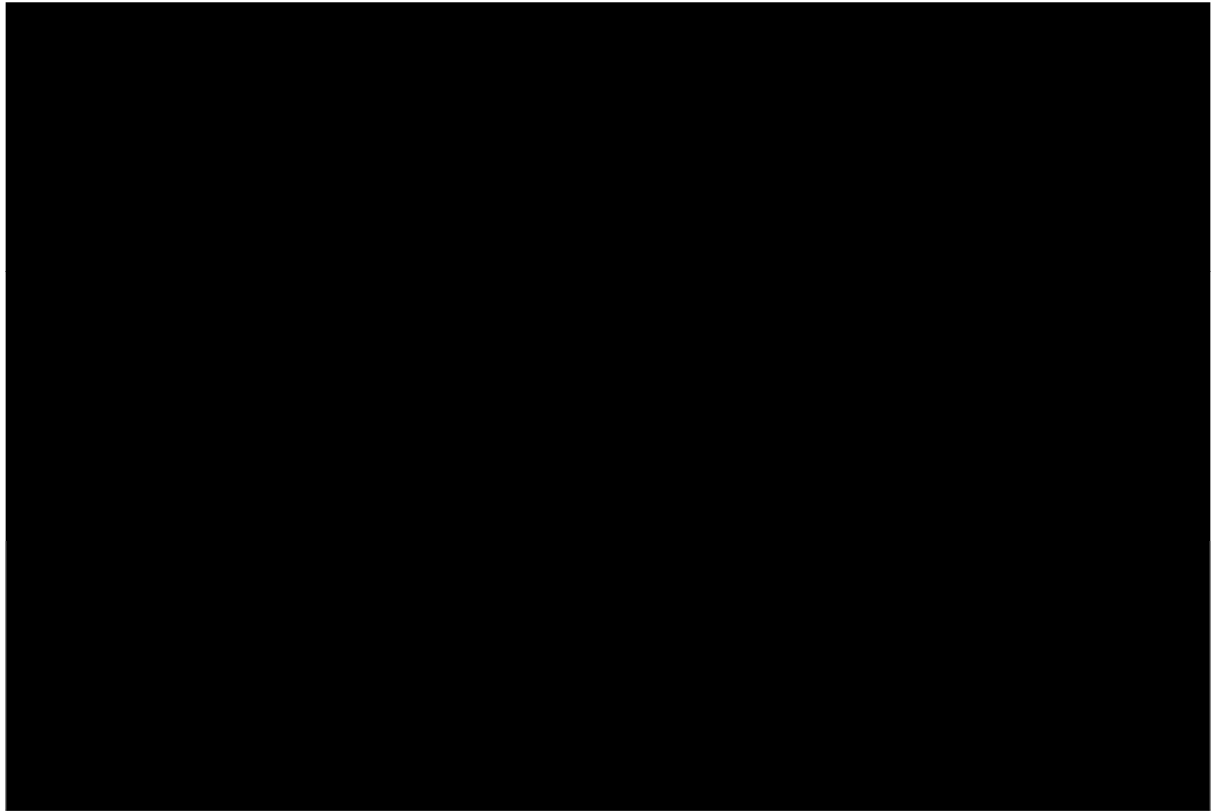

For both lenalidomide and observation, the log normal and Gompertz distributions appear to substantially deviate from the CALGB 100101 PFS Kaplan–Meier (overestimate and underestimate respectively, Figure 13). In addition, the Gompertz distribution for lenalidomide crosses the CALGB 100101 Kaplan–Meier curve for observation, violating clinical plausibility for survival in the untreated population. Log-normal and Gompertz will not be considered any further.

Although the Weibull and Gamma distributions fit the Myeloma XI Kaplan–Meier, they underestimate that of CALGB 100101 over the longer term for both lenalidomide and observation.

The log-logistic and exponential distributions are the most plausible extrapolations when considering fit to the CALGB 100101 PFS curves. The exponential distribution was chosen for the base case because the log-logistic provides optimistic estimates for PFS, predicting that 5% of untreated patients would remain in pre-progression at

20 years. Therefore, the exponential for both lenalidomide and observation is the most appropriate extrapolation for the model base case.

Figure 13

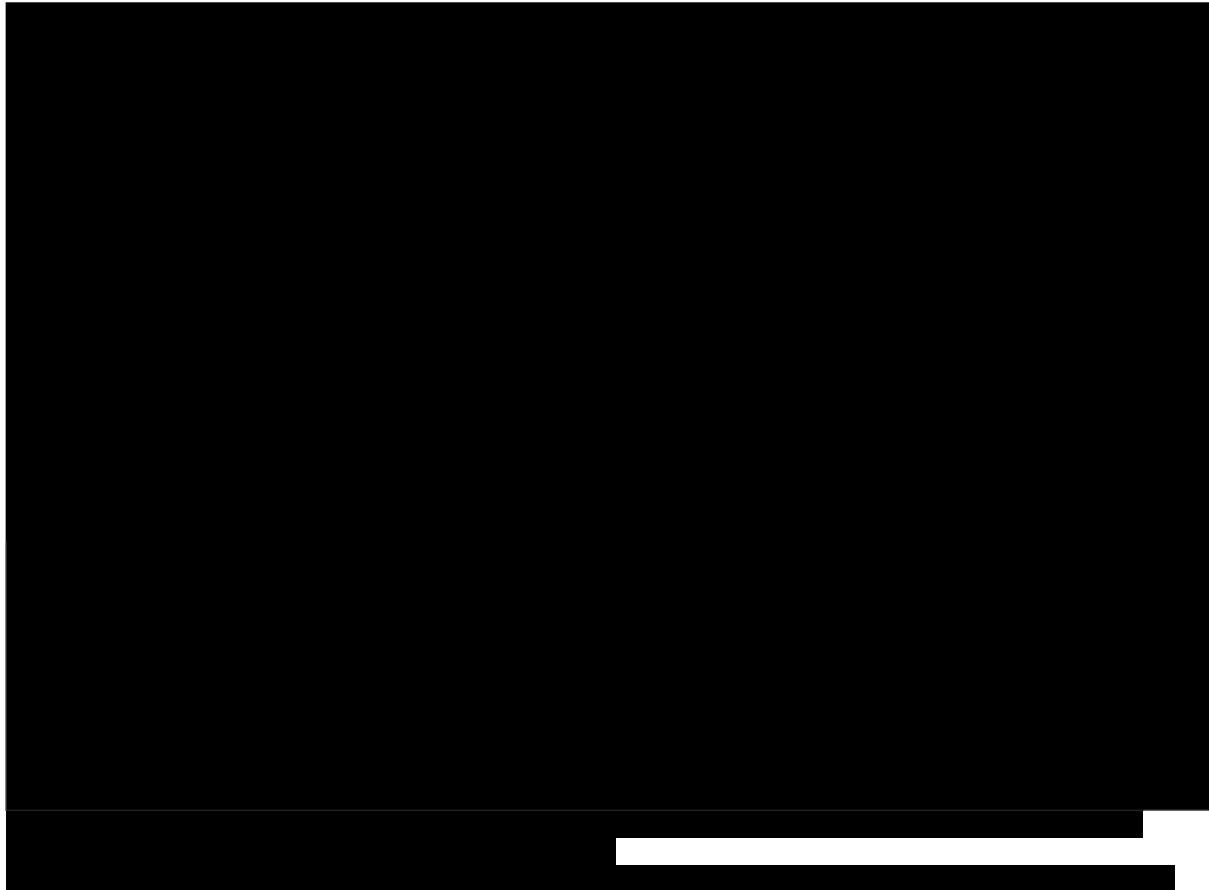

B.3.2.5.2 OS distribution selection

Both joint models and independent models were fitted. Joint models provided reasonable fit to the observation KM in most cases, but largely deviated from the lenalidomide KM, generating unsatisfactory approximations of both curves at the same time and therefore unsuitable for valid extrapolation (Figure 14). Therefore, independent models were used.

Figure 14

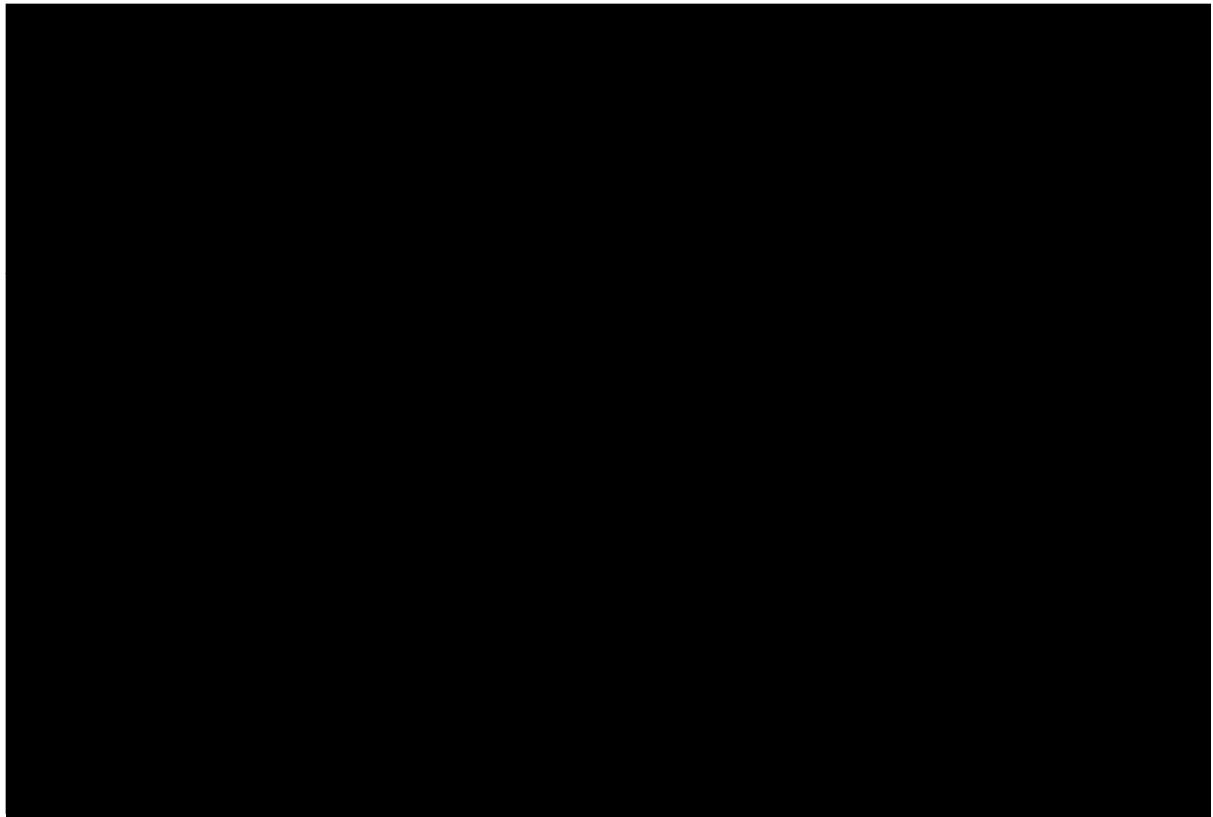

AIC and BIC statistics for independent models (Table 23) indicate that the generalised gamma model provides the best fit to the observed within-trial data. The generalised gamma, log-log, Weibull and lognormal distributions had a comparable fit, whilst the exponential models consistently ranked as worst fit. When using the BIC, the exponential and Weibull distributions for lenalidomide were the worst fit to the Myeloma XI data.

Table 23. Parametric survival curves for OS – goodness of fit statistics

Model	Lenalidomide				Observation			
	AIC	AIC rank	BIC	BIC rank	AIC	AIC rank	BIC	BIC rank
GG	1109.5	1	1118.4	1	1311.6	1	1319.7	1
LL	1109.7	2	1118.5	2	1312.8	3	1320.8	2
Wei	1111.5	4	1124.8	5	1312.7	2	1324.7	5
LN	1110.7	3	1119.5	3	1314.1	5	1322.1	4
Gom	1112.7	5	1121.6	4	1312.9	4	1320.9	3
Exp	1123.7	6	1128.1	6	1326.2	6	1330.2	6

AIC, Akaike Information Criterion; BIC, Bayesian Information Criterion; Exp, exponential; GG, generalised gamma; Gom, Gompertz; LL, log-logistic; LN, log-normal; OS, overall survival; Wei, Weibull.

Visual inspection (Figure 15) illustrate that all models except the exponential provide a reasonable visual fit for the Myeloma XI Kaplan–Meier.

Figure 15

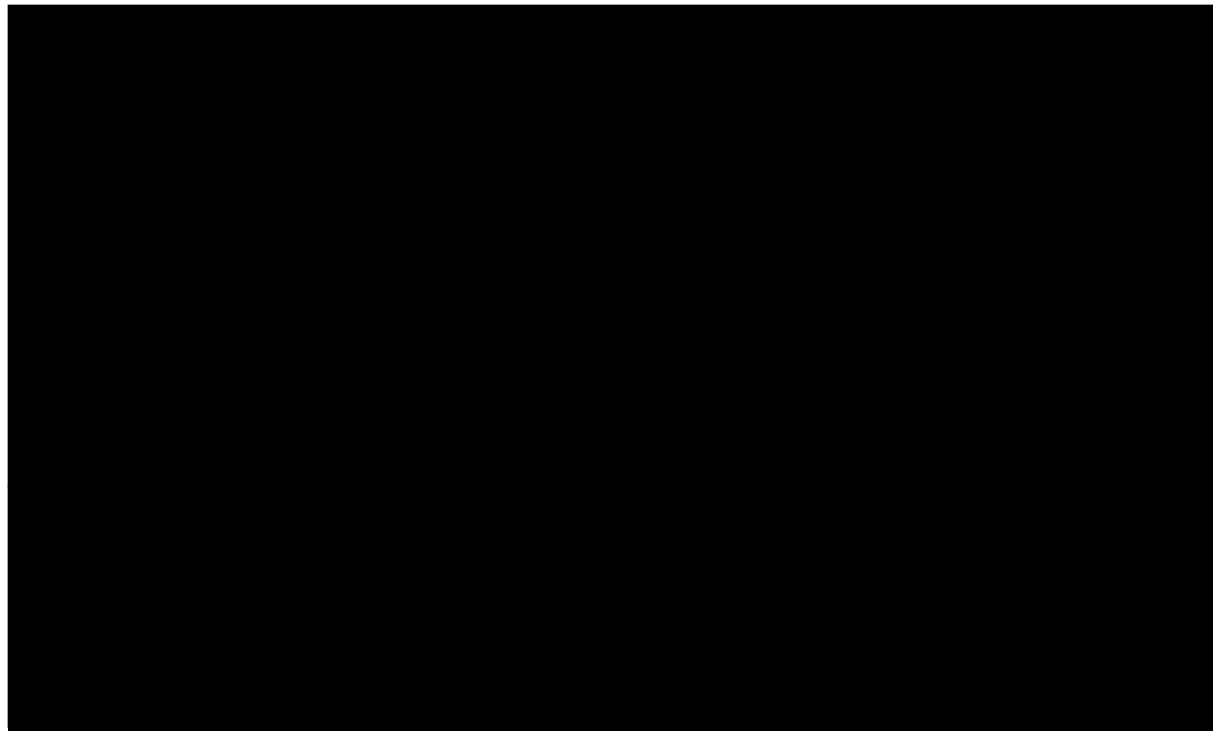



CALGB 100101 validation

The Kaplan–Meier curves (Figure 16) appear similar over time. OS curves in CALGB 100101 appear to separate further over longer follow up, suggesting that the PH assumption may not hold in the longer term, although this hypothesis cannot be challenged with Myeloma XI data.

Figure 16 

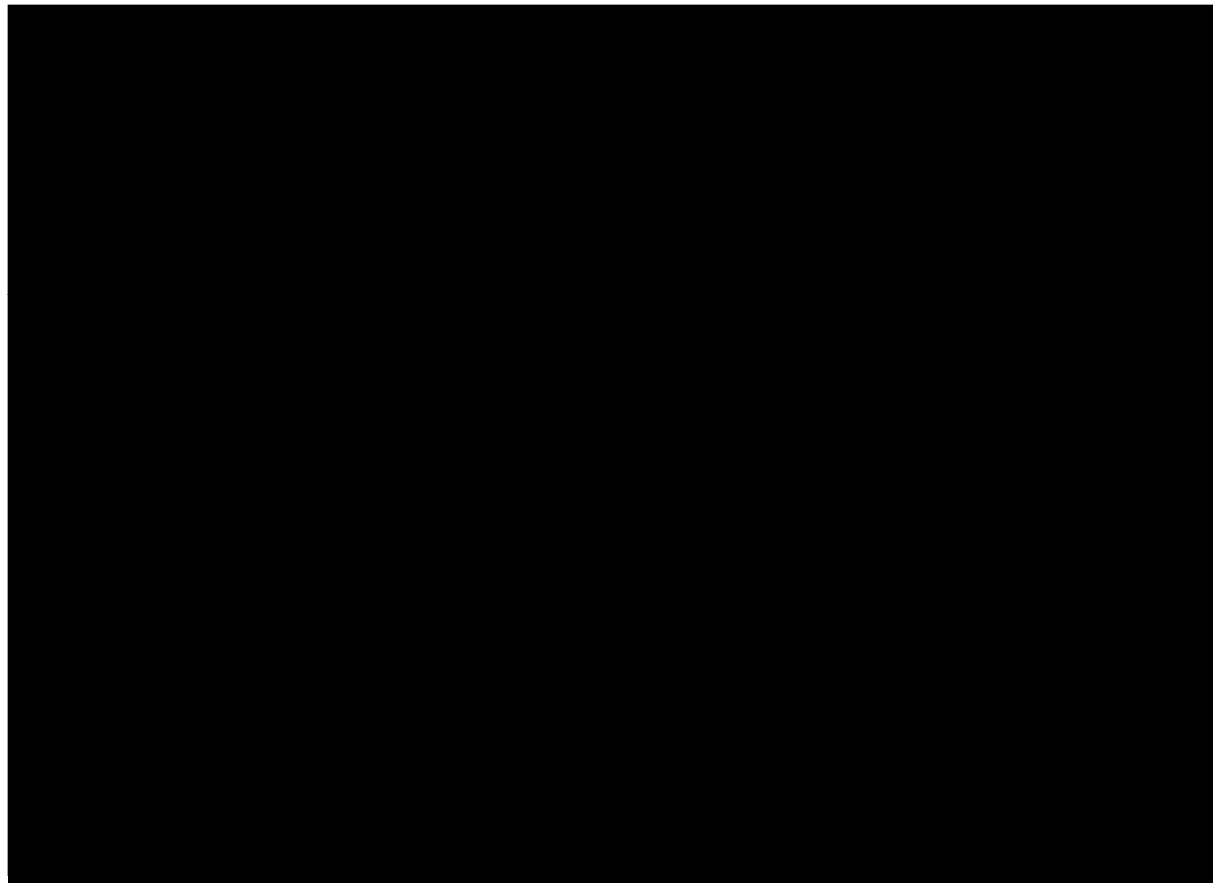

For both lenalidomide and observation, the exponential and Gompertz distributions poorly fit the CALGB 100101 Kaplan–Meier (in alignment with AIC and BIC rankings) and will therefore not be considered any further.

For observation, the Weibull appears the best and most plausible distribution as it closely fits both Myeloma XI and the CALGB 100101 data over the entire follow-up of this study. The generalized gamma, log-logistic, log-normal models do not provide better fit to the Myeloma and CALGB 100101 data up to 5 years, whilst they substantially deviate from the survival Kaplan–Meier over the longer term.

Figure 17. [Redacted]

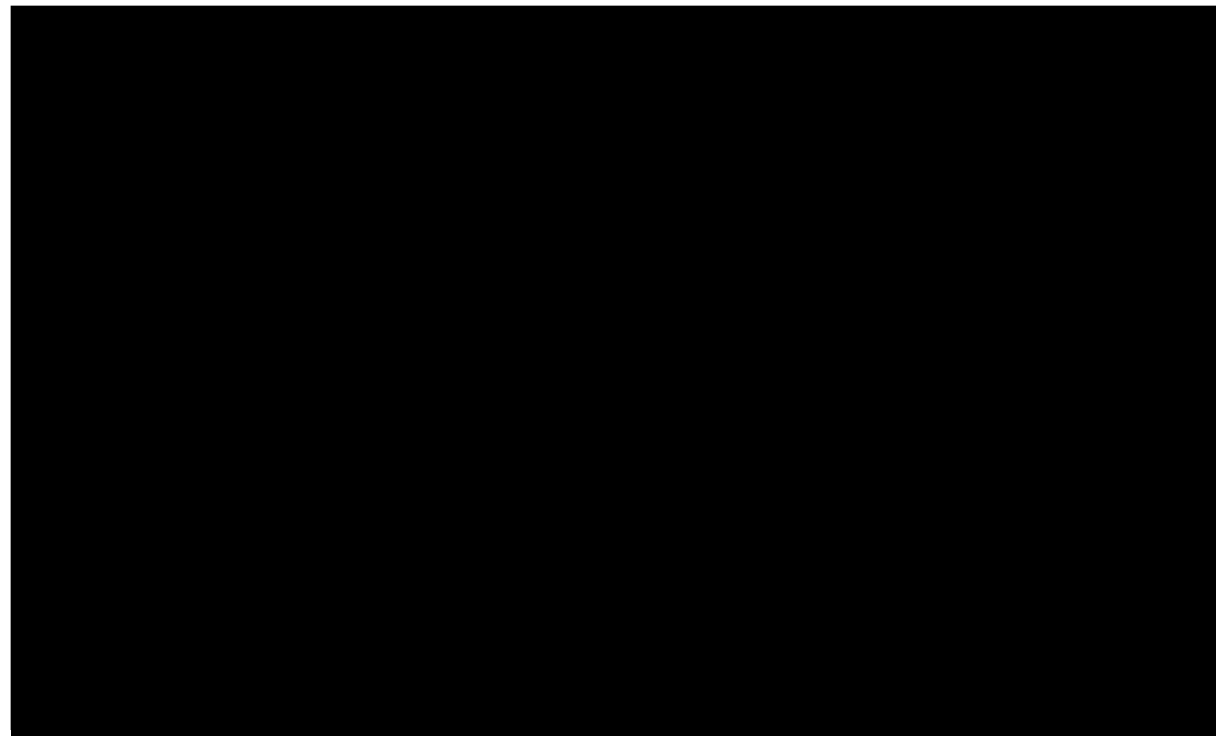

[Redacted]

For lenalidomide, the most plausible distributions are the log-logistic, generalised gamma and log-normal (Figure 17) although none closely fits CALGB 100101; the log-normal however overestimates the proportion of people who will remain alive in the longer term, approximately 35% of patients alive at 20 years. The log-logistic was considered the most reasonable fit against the CALGB 100101 Kaplan–Meier curve

for lenalidomide for the base case, whilst the generalised gamma was deemed the next most plausible fit. The Weibull was the least plausible as it largely underestimated the CALGB 100101 Kaplan–Meier.

In summary, the model uses the following base case:

- PFS: exponential distribution for both lenalidomide and observation (Figure 18).
- OS: log-logistic and Weibull distributions for lenalidomide and observation, respectively (Figure 19)

Figure 18



Figure 19. [REDACTED]

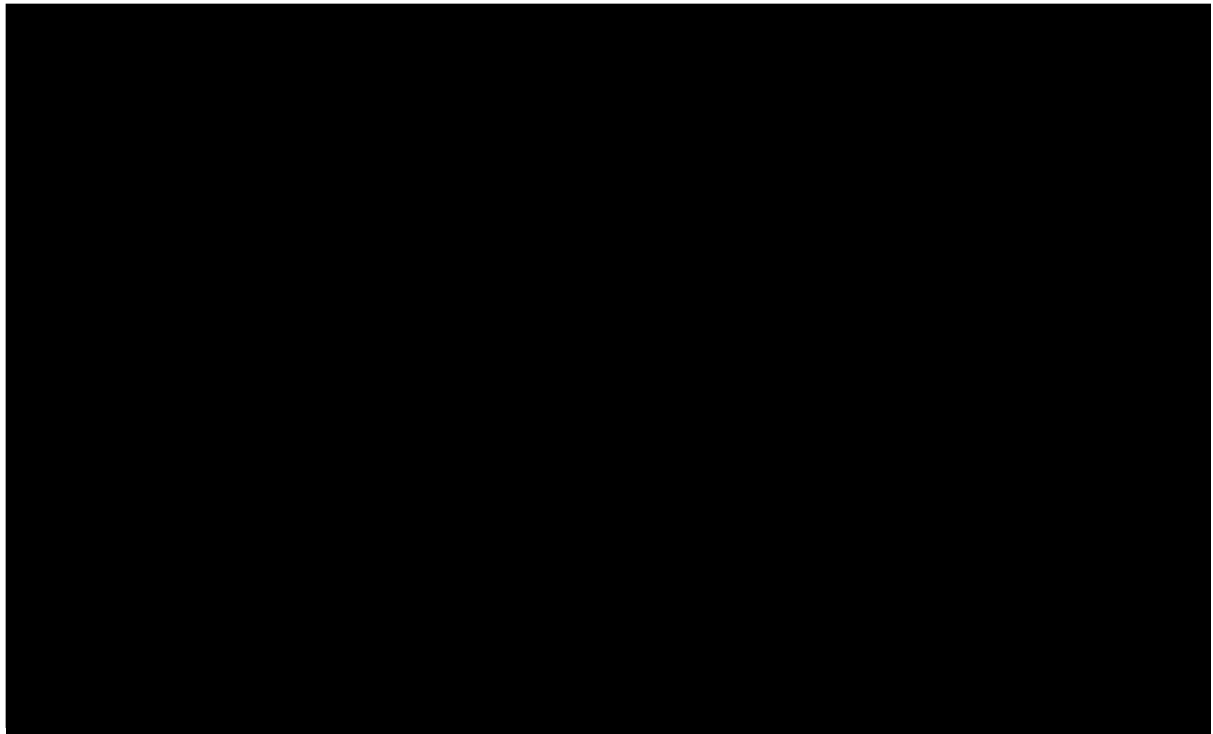

[REDACTED]

Scenario analyses were conducted using generalised gamma for lenalidomide OS and PFS.

B.3.2.6 Time on lenalidomide maintenance treatment

The Kaplan–Meier for time on treatment (ToT) (Figure 19) was obtained using discontinuation (as recorded by investigators) data from the lenalidomide Myeloma XI safety set (n=582, of which [REDACTED]

[REDACTED]. [REDACTED]

[REDACTED] compared with CALGB (median 25.4 months, 95% CI 19.9 - 30.8, n = 224, 16.1% on treatment at last follow-up).

Figure 20.



Parametric curves were fitted to Myeloma XI time on treatment. Goodness of fit statistics (Table 24) indicate that the exponential curve provides the best fit to the observed within-trial period based on both AIC and BIC. All models appear to have comparable fit, with the exception of the log-normal distribution.

Table 24. Parametric survival curves for TOT – goodness of fit statistics

Distribution	AIC	AIC rank	BIC	BIC rank
Exponential	2037.5	1	2041.9	1
Weibull	2039.1	2	2047.8	2
Gompertz	2039.1	3	2047.9	3
Generalized gamma	2040.8	4	2053.9	5
Log-logistic	2040.9	5	2049.6	4
Log-normal	2045.9	6	2054.7	6

Abbreviations: AIC, Akaike information criterion; BIC, Bayesian information criterion; TOT, time on treatment.

From visual assessment of the parametric curves (Figure 21) all models give a plausible fit to the Myeloma XI Kaplan–Meier, except for the log-normal and log-logistic models that slightly overestimate TOT after approximately 36 months. The similarity of fit between curves may explain why the AIC and BIC favour the simplest, exponential model. Therefore, the exponential distribution was selected for the base case (Figure 21).

Alternative scenarios were tested using the log-normal and log-logistic models.

Figure 21.



. For this reason, the probability of remaining on treatment in the model was rescaled using a

B.3.2.7 Lenalidomide dosing

A dose of 10 mg OD was assumed throughout the economic evaluation, with costs adjusted using the relative dose intensity (RDI), to ensure consistency with outcomes data. The treatment relative dosing intensity was also derived from Myeloma XI data, using real dosage data for lenalidomide as recorded by investigators. At the recommended dose of 10mg/day [REDACTED]

[REDACTED]. Although a small number of patients had missing data (n = 11), missing value imputation (0% RDI-imputed, 100% RDI-imputed, and excluding these patients from the analysis) provided negligible differences in the mean RDI.

B.3.3 Measurement and valuation of health effects

B.3.3.1 Health-related quality-of-life data from clinical trials

None of the three registration studies or Myeloma XI collected preference-based measures of HRQoL. It was therefore necessary to source estimates of utility values from published studies.

B.3.3.2 Mapping

Mapping was not conducted as patient-level quality of life data was not available from clinical studies.

B.3.3.3 Health-related quality of life studies

Utilities from the study by Acaster et al,¹¹¹ were used in the model. The authors conducted a cross-sectional postal survey of 605 UK patients with MM. Respondents were asked to rate their HRQoL using the EQ-5D-3L. The EQ-5D-3L is a generic, preference-based measure of HRQoL and is the measure of HRQoL in adults preferred by NICE.¹¹⁸ The tariff applied was estimated by Dolan et al¹¹⁹ and is consistent with the reference case.¹¹⁸

The survey defined 'first-line treatment', 'second-line treatment', 'later stage' and 'first treatment-free interval', as follows:

- First-line: first treatment received for myeloma;

- Second-line: treatment received after first relapse, either a repeat of first-line treatment (with good response) or alternative treatment;
- First treatment-free interval: first time a patient is classed as being in remission, and the patient is not receiving any active myeloma or maintenance treatment (although concomitant treatment is possible, e.g. painkillers or anaemia medication);
- Later stage: time from second remission onwards.

B.3.3.4 Adverse events

Adverse events were incorporated as utility decrements in the lenalidomide arm, calculated from the rate of adverse events in Myeloma XI, multiplied by the utility weight and adjusted for the duration of each adverse events.

Adverse event rates were Grade 3 or greater in at least 2% of patients treated with lenalidomide in Myeloma XI.⁵ The rate of adverse events per cycle was calculated based on number of individuals reporting each adverse event in the lenalidomide arm, over the median duration of follow-up in Myeloma XI.⁵ The study reported number of people who experienced adverse events rather than number of events per se. We assumed that this number would be a reasonable approximation of number of adverse events because adverse events are generally not expected to recur in practice. Adverse events rates were explored in the sensitivity analysis to assess the impact of this assumption.

Utility weights and duration by type of adverse events were obtained from a previous manufacturer's submission (TA510).¹²⁰

Adverse events were not assigned to the observation arm, as they were not reported in Myeloma XI.⁵ Non-zero adverse events rates were observed in the CALGB 100101 observation arm, therefore suggesting the approach may be conservative.

Table 25

B.3.3.5 Health-related quality of life data used in the cost-effectiveness analysis

Following the review of studies identified by the SLR (Appendix H), the base-case analysis uses data presented by Acaster et al (Table 26).¹¹¹

For the pre-progression health state, utility scores for the first treatment-free interval were assumed to reflect baseline utility for people who underwent ASCT, and currently receiving observation. The model assumed no differences in utility scores between patients receiving lenalidomide or observation.¹²¹

Second line utility weights from Acaster were assigned to the model post-progression state.

Utilities were also adjusted to decline in relation with age.¹²² A utility correction was applied to the pre-progression and post-progression utilities; the correction factor was calculated from age-specific utilities, relative to the age-specific utility of the cohort age at model start. Declining utility with age is a conservative assumption (i.e. likely to lead to a worse ICER for lenalidomide), because utility decreases as people progress to further stages of disease; the model does not explicitly model time to

further progressions after first progression; as it is likely that people on observation will progress faster, but the faster decline in corresponding utility was not modelled.

Table 26. Summary of utility values for cost-effectiveness analysis

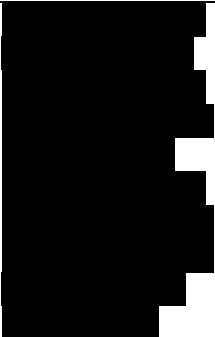
State	Utility value: mean	95% CI	Reference in submission (section and page number)	Justification
Health state utility values				
Pre-progression	0.72	0.69, 0.75 ^a	B 3.3.3.	
Progressive disease	0.67	0.64, 0.70 ^a		

CI, confidence interval.

^aCalculated using standard deviation reported by Acaster et al ¹¹¹.

Alternative sources of utility data for health states were used in sensitivity analyses and are summarised in Table 27.

Table 27. Summary of utility values for scenario analysis

Source	State	Utility value mean (SD)
Hatswell <i>et al.</i>	PFS	0.62 (0.46, 0.79) ^a
	PD	0.59 (0.57, 0.61)

PD, progressed disease; PFS, progression-free survival; SD, standard deviation.

^aCalculated using standard deviation.

Utility decrements for adverse events (Table 28) were obtained from NICE TA510.¹²⁰

Table 28. Summary of utility values for adverse events

Adverse event	Utility decrement	95% CI	Reference to section in submission
Neutrophil count decrease (neutropenia)	-0.39	-0.24, -0.55	B.3.3.4
Anaemia	-0.31	-0.20, -0.44	
Platelet count decrease (thrombocytopenia)	-0.31	-0.20, -0.44	
Lower/upper respiratory infection	-0.19	-0.12, -0.27	
Sepsis	-0.20	-0.12, -0.28	
Infestations and infections	-0.20	-0.12, -0.28	

CI, confidence interval.

B.3.4 Cost and healthcare resource use identification, measurement and valuation

Costs considered in the model include maintenance drug costs, medical resource use costs for follow-up and monitoring, and post-progression therapy costs.

Maintenance drug costs and adverse event management costs are considered in the lenalidomide arm only.

B.3.4.1 Intervention and comparators' costs and resource use

Lenalidomide drug costs were applied to the proportion of patients remaining on treatment in each model cycle, based on time on treatment (section B.3.2.6).¹²³

The cost of lenalidomide was the acquisition cost, adjusted by RDI, with no wastage and no additional administration costs, as it is an oral treatment. The acquisition cost of lenalidomide was accrued in the model at the start of each 28-day period (half cycle correction not applied).

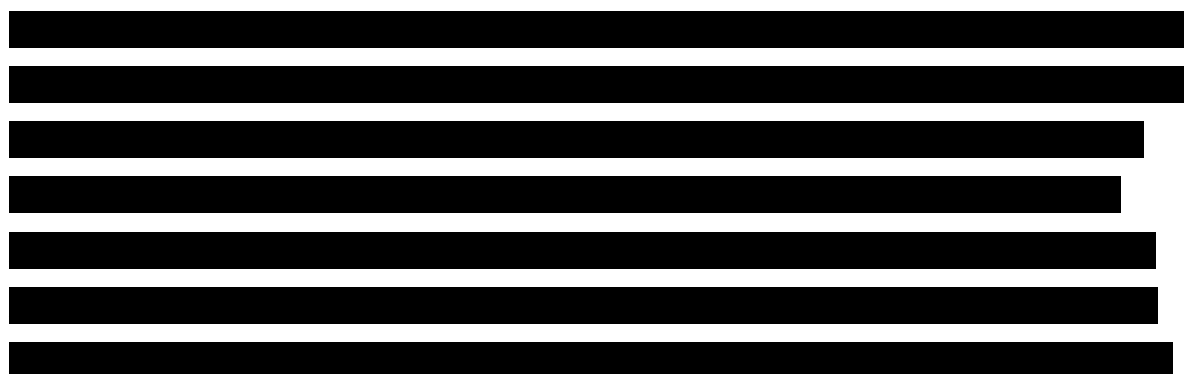

[REDACTED]

[REDACTED]

[REDACTED]

[REDACTED]

[REDACTED]

[REDACTED]

[REDACTED]

Table 29. Lenalidomide as maintenance acquisition costs

[REDACTED]	Administrati on days/cycle	List price per pack ^a	Units per pack	Cost per cycle	RDI	Cost per cycle with RDI applied
[REDACTED]	■	■	■	■	■	■
[REDACTED]	■	■	■	■	■	■

^aSource: British National Formulary ¹²⁴
 PAS, patient access scheme; RDI, relative dose intensity.

No initial drug costs were applied to observation.

B.3.4.2 Medical resource use costs

Medical resource use and costs were applied to both maintenance and observation in the model (B.3.4.2) to capture the costs of monitoring. Resource use included routine monitoring and care of multiple myeloma patients and differed between health states, as in TA587.¹²⁵ Medical resource use was informed by clinical practice, and therefore assumed to be more relevant to the decision problem, rather than taken from Myeloma XI where use was protocol driven.

To calculate the cost per year for routine laboratory tests and monitoring, resource use was obtained from questionnaires completed by seven UK clinicians in 2015,¹²⁶ who were asked to provide annual rates of laboratory tests and monitoring patterns for frontline treatment in transplant ineligible patients and in subsequent lines (i.e. post-progression). It was assumed that the cost of medical care during induction and during maintenance would be similar. The cost was applied to both maintenance and observation.

Laboratory tests unit costs were obtained from the most recent NHS reference costs (2017–2018) and uplifted to 2018/19.¹²⁷ Unit costs for medical resource use are presented in Appendix N.

B.3.4.3 Adverse events costs

The model included costs associated with managing Grade 3 and greater adverse events that occurred in $\geq 2\%$ of patients treated with lenalidomide. Adverse event costs were applied to the maintenance arm but not to observation. Unit costs for adverse event episodes were taken the NHS reference costs (2017–2018; Table 30)¹²⁷ weighted by activity across each complication score to capture the average severity. Frequencies of adverse events are reported in section B.2.10.

Table 30. Adverse event costs

Adverse reactions during lenalidomide maintenance	Cost ^a	HRG code
Neutrophil count decrease (neutropenia)	£382.38	Weighted average of the codes: SA08G, SA08H, SA08J for Other Haematological or Splenic Disorders
Anaemia	£296.19	Weighted average of the codes: SA04G, SA04H, SA04I, SA04J, SA04K, SA04L for Iron Deficiency Anaemia
Platelet count decrease (thrombocytopenia)	£280.28	Weighted average of the code: SA12G, SA12H, SA12J, SA12J, SA12K for Thrombocytopenia
Lower/upper respiratory infection	£609.08	Weighted average of the codes: DZ19H, DZ19J, DZ19K, DZ19L for Other Respiratory Disorders
Sepsis	£403.78	WH07D: Infections or Other Complications of Procedures, with Single Intervention, with CC
Infestations and infections	£403.78	WH07D: Infections or Other Complications of Procedures, with Single Intervention, with CC

^aSource: NHS Reference Costs 2017–2018; Day case costs¹²⁷. Further subject to uplift to 2018/19 prices. HRG, healthcare resource group.

B.3.4.4 Subsequent treatment costs

In Myeloma XI, all patients received further antimyeloma treatment after the first PFS event, and [REDACTED].⁵

The cost of subsequent treatment lines was included in the model based on the frequencies of further treatments lines, drug and administration costs and duration of treatment.

The cost of further treatment lines was the sum of drug acquisition cost and administration costs. The cost of adverse event during subsequent treatments were not included as these are likely to represent a very small proportion of the incremental cost. The cost of disease monitoring (i.e. laboratory and monitoring tests) were assumed to be accounted for in the medical resource use (which is state specific).

Currently, lenalidomide is reimbursed in this patient population for use after second relapse. In the event that maintenance with lenalidomide is reimbursed, a change in future treatment pathways is highly likely, because patients treated with lenalidomide in maintenance should not be retreated with lenalidomide-containing regimens,¹²⁸ (Section B2) and as confirmed by clinical experts consulted during NICE TA587).¹²⁵ Conversely, lenalidomide would continue to be available in later lines to these patients should they receive no maintenance, as in the observation arm of the model (status quo).

Further, new treatments for multiple myeloma, such as the combination of daratumumab, bortezomib and dexamethasone,⁸⁰ carfilzomib and dexamethasone⁷⁷ and ixazomib + lenalidomide + dexamethasone,¹⁰⁴ have become available as a result of both recent NICE reimbursement decisions and via the Cancer Drugs Fund. Such changes apply both to pathways reflected in the observation arm of the model (status quo) as well as to clinical pathways relevant for the maintenance arm.

For these reasons, the mix of subsequent therapies observed in Myeloma XI (Appendix P), reflecting clinical pathways in place when the trial was conducted, may no longer be representative of currently and future subsequent treatments, resulting in unrealistic and potentially inaccurate estimation of costs of care displaced by the introduction of maintenance in the multiple myeloma pathway.

A survey was conducted to elicit the frequencies of subsequent treatments types that would be used after first and second relapse from a convenience sample of eight UK physicians specialised in multiple myeloma (Appendix P). The resulting distribution

[REDACTED]

[REDACTED]. When clinicians indicated 'Other', the cost of chemotherapy was assumed. A discount of 15% was applied to the acquisition price for bortezomib, drawing on a simplified assumption reported in TA573.^{130,d} PAS agreements for other treatments are not publicly avail, hence no discounts were applied.

^d Not reported in **Error! Reference source not found.**

Table 32. Subsequent therapy costs

Regimen	Drug	Dose /day (mg)	Administration days/cycle	Price per pack	RDI (%)	Cost per cycle	Total cost per cycle
Lenalidomide + dexamethasone	██████████	████	████	████	████	████	████
	Dexamethasone	40	4	£20 ‡	95	£8	
Daratumumab	Daratumumab	16/kg	3.08	£360 †	98	£12,863	£12,863
Bortezomib + dexamethasone	Bortezomib	1.3/m ²	4	£762 †	87	£2,048	£2,058
	Dexamethasone	20	8	£20 ‡	95	£10	
Carfilzomib + dexamethasone	Carfilzomib	56/m ²	6	£1,056 †	94	£10,228	£10,236
	Dexamethasone	20	8	£20 ‡	94	£8	
Thalidomide + melphalan + prednisolone	██████████	████	████	████	████	████	████
	Melphalan	0.15/kg	4	£137 †	100	£97	
	Prednisolone	60/m ²	7	£8 ‡	100	£24	
Ixazomib + lenalidomide + dexamethasone	Ixazomib	4	3	£6,336 †	93	£5,899	████
	██████████	████	████	████	████	████	
	Dexamethasone	40	4	£20 ‡	93	£7	
Panobinostat + bortezomib + dexamethasone	Panobinostat	20	6	£4,656 †	81	£5,010	£6,808
	Bortezomib	1.3/m ²	4	£762 †	76	£1,790	
	Dexamethasone	40	4	£20 ‡	88	£8	
Bendamustine + prednisolone	Bendamustine	100/m ²	2	£19 †	80	£57	£79
	Prednisolone	100/m ²	5	£8 ‡	80	£23	
Conventional chemotherapy	Melphalan	25/m ²	1	£137 †	100	£101	£120
	Prednisolone	60/m ²	7	£8 ‡	100	£19	
DTPACE	Dexamethasone	40	4	£20 ‡	100	£8	████
	██████████	████	████	████	████	████	
	Cisplatin	10/m ²	4	£16 ‡	100	£116	
	Doxorubicin	10/m ²	4	£16 ‡	100	£115	
	Cyclophosphamide	400/m ²	4	£8 ‡	100	£49	

Company evidence submission for post-ASCT maintenance with lenalidomide (ID475)

Regimen	Drug	Dose /day (mg)	Administration days/cycle	Price per pack	RDI (%)	Cost per cycle	Total cost per cycle
	Etoposide	40/m ²	4	£4 ‡	100	£109	
Steroid only	Dexamethasone	40	12	£20 ‡	100	£24	£24
Pomalidomide + dexamethasone	Pomalidomide	4	21	£8,884 †	100	██████	██████
	Dexamethasone	40	4	£20 ‡	100	£8	
Daratumumab + bortezomib + dexamethasone	Daratumumab	16/kg	1.31	£360 †	94	£6,982	£8,921
	Bortezomib	1.3/m ²	4	£762 †	82	£1,930	
	Dexamethasone	20	8	£20 ‡	87	£9	

† Source: NHS Reference Costs 2017-2018 ¹²⁴.

‡ Source: Drugs and pharmaceutical electronic market information tool (eMIT) ¹²⁹.

Abbreviations: DTPACE, combination of dexamethasone, thalidomide, cisplatin, doxorubicin, cyclophosphamide and etoposide; PAS, patient access scheme; RDI, relative dose intensity.

Administration costs for intravenous and oral therapies were obtained from NHS reference costs (2017–2018, uplifted to 2018/19 prices).

The duration of treatment for each subsequent therapy by line of treatment is reported in Table 33. The duration of subsequent therapy is assumed not to be impacted by the treatment received in the ‘progression-free’ state.

Table 33. Subsequent treatment use

Therapy	Assumption for time on treatment (cycles)		Source
	1st relapse	2nd relapse	
[REDACTED]	[REDACTED]	[REDACTED]	NICE TA586 ¹³¹
Daratumumab	3.7	3.7	NICE TA510 ¹²⁰
Bortezomib + dexamethasone	7.6	7.6	NICE TA573 ¹³⁰
Carfilzomib + dexamethasone	9.8	9.8	
[REDACTED]	[REDACTED]	[REDACTED]	NICE TA505 ¹³²
[REDACTED]	[REDACTED]	[REDACTED]	
Panobinostat + bortezomib + dexamethasone	5.4	5.4	
Bendamustine	4.0	4.0	
Conventional chemo	12.0	12.0	NICE TA586 ¹³¹
DTPACE	3.0‡	3.0‡	South East London Cancer Network ¹³³
Dexamethasone	2.4	2.4	NICE TA427 ¹³⁴
[REDACTED]	[REDACTED]	[REDACTED]	
Daratumumab + bortezomib + dexamethasone	25.5	25.5	NICE TA573 ¹³⁰
	6.0	6.0	

†Assumed to be the same as THAL + DEX.

‡Assumption based on maximum of 3 cycles.¹³³

Abbreviations: DEX, dexamethasone; DTPACE, combination of dexamethasone, thalidomide, cisplatin, doxorubicin, cyclophosphamide and etoposide; NICE, National Institute for Health and Care Excellence; THAL, thalidomide.

Subsequent therapy costs were applied to PFS events in the period in which they occur. For simplicity, it was assumed that the first subsequent treatment starts upon progression, although it is recognised that in clinical practice there may be a delay

between progression and initiation of subsequent treatment. It was further assumed that the costs of subsequent therapies after first and second relapse are incurred at the same time and that patients would experience two further treatment lines of therapy.

Discounting was applied for the duration of treatment with the respective subsequent therapy (or end of the time horizon, whichever shorter), using a continuous discounting function:¹³⁵ for drug cost c per year, accrued for an average duration of treatment of s years from time of disease progression t , and γ is the logarithm of 1.035, then the total discounted cost for a given subsequent treatment is

$$\int_t^{t+s} ce^{-\gamma\tau} d\tau = \frac{ce^{-\gamma t}}{\gamma} (1 - e^{-\gamma s})$$

A scenario analysis was conducted to test the impact of using the distribution of subsequent therapies obtained from Myeloma XI (Appendix P).

B.3.5 Summary of base-case analysis inputs and assumptions

B.3.5.1 Summary of base-case analysis inputs

Table 34 summarises the variables and distributions applied in the economic model.

Table 34. Summary of variables applied in the economic model

Variable	Value (reference to appropriate table or figure in submission)	Measurement of uncertainty and distribution: CI (distribution)	Reference to section in submission
OS distributions	Lenalidomide: log-logistic observation: Weibull	Multivariate normal	B.3.2.5.2
PFS distributions	Lenalidomide: exponential observation: exponential	Multivariate normal	B.3.2.5
ToT distributions	Lenalidomide: exponential	Multivariate normal	B.3.2.6
Pre-progression utility	0.72	0.69, 0.75 (beta)	B.3.3.5
Progressive disease utility	0.67	0.64, 0.70 (beta)	B.3.3.5
AE disutility	Table 25	Gamma	B.3.3.4
AE rates	Table 25	Beta	B.3.3.4
AE costs	Table 30	Lognormal	B.3.4.3
Resource use rates	Medical resource use rates, Table 94 (Appendix N)	Lognormal	Appendix N
Resource use costs	Medical resource use rates, Table 94 (Appendix N)	Lognormal	Appendix N
Distribution of subsequent therapies	Table 31	Gamma	B.3.4.4

AE, adverse event; CI, confidence interval; OS, overall survival; PFS, progression-free survival; ToT, time on treatment.

B.3.5.2 Assumptions

Table 34 details the assumptions used in the economic model and the associated justifications.

Table 35: Model assumptions

Assumption	Justification	Reference in submission
PFS curve is prevented from crossing OS	To prevent illogical outcomes	B.3.2.2
Mortality rates do not fall below that of the general population	This patient population has life expectancy no better than the general population, or worse	B.3.8
Independent statistical models are used for lenalidomide and joint models observation which were extrapolated directly from Myeloma XI	Log-cumulative hazard plots did not provide conclusive information on the applicability of proportional hazards or otherwise. Comparison to longer-term follow-up from CALGB 100101 was used to establish which distributions for each model arm were more appropriate.	B.3.2.5.2
Base-case distribution – OS Lenalidomide: log-logistic observation: Weibull	This selection of distributions provides the most plausible fit to the long-term follow-up data available from CALGB 100101	B.3.2.5.2
Base-case distribution – PFS Lenalidomide: exponential observation: exponential	This selection of distributions provides the most plausible fit to the long-term follow-up data available from CALGB 100101	B.3.2.5.1
Utilities depend on health state and are equal between arms	There are no data that show evidence for a lenalidomide-specific utility benefit.	B.3.3.5
AEs are only applied in the treatment arm	No active treatment is used in the observation arm, no adverse events are modelled.	B.3.3.4
AEs considered include Grade 3 or greater AEs occurring in ≥2% of patients	The analysis only considered AEs that were expected to be a determinants of cost.	B.3.4.3
Medical resource differs by health state but is the same for both arms	This assumption was made in the absence of other data.	B.3.4.2
AE costs were not included for subsequent therapies	A simplifying assumption informed by a lack of data	B.3.4.3
The distribution of subsequent therapies is based on clinicians' questionnaires reflecting the	This is consistent with the expected use of products and clinical practice and is	B.3.4.4

distribution of the most likely treatment choices	consistent with the marketing authorisations and reimbursement status for the respective products.	
---	--	--

AE, adverse event; observation, best supportive care; OS, overall survival; PFS progression-free survival; SmPC, summary of product characteristics; TEAE, treatment-emergent adverse event.

B.3.6 *Base-case results*

B.3.6.1 **Base-case incremental cost-effectiveness analysis results**

In the base-case analysis, lenalidomide is associated [REDACTED] [REDACTED] [REDACTED] (Table 36). Full disaggregated outcomes are reported in Appendix J.

The cost-effectiveness is driven by the QALY gain based on long-term extrapolation of OS from Myeloma XI (validated using CALGB 100101), together with the offsetting of subsequent therapy costs [REDACTED] [REDACTED]

[REDACTED]

[REDACTED]

[REDACTED]

[REDACTED]

[REDACTED]

[REDACTED]

[REDACTED]

[REDACTED]

Table 36. Base-case results

[REDACTED]	[REDACTED]	[REDACTED]	[REDACTED]	[REDACTED]	[REDACTED]	[REDACTED]	[REDACTED]
[REDACTED]	[REDACTED]	[REDACTED]	[REDACTED]	[REDACTED]	[REDACTED]	[REDACTED]	[REDACTED]
[REDACTED]	[REDACTED]	[REDACTED]	[REDACTED]	[REDACTED]	[REDACTED]	[REDACTED]	[REDACTED]

Abbreviations: observation, best supportive care; ICER, incremental cost-effectiveness ratio; LYG, life years gained; QALY, quality-adjusted life year.

B.3.7 Sensitivity analyses

B.3.7.1 Probabilistic sensitivity analysis

Probabilistic sensitivity analysis (PSA) was performed by varying all inputs simultaneously over 1,000 iterations, based upon their respective distributions (section B.3.5.1). The results are presented on a cost-effectiveness plane (Figure 22) and as a cost-effectiveness acceptability curve (CEAC; Figure 23). The probability that lenalidomide was cost-effective at thresholds of £30,000 and £20,000 per QALY gained was [REDACTED]

Table 37. Probabilistic incremental cost-effectiveness analysis results (with PAS)

Treatment	Total costs (£)	Total QALYs	Incremental costs (£)	Incremental QALYs	ICER (£/QALY)
[REDACTED]	[REDACTED]	[REDACTED]	[REDACTED]	[REDACTED]	[REDACTED]
[REDACTED]	[REDACTED]	[REDACTED]	[REDACTED]	[REDACTED]	[REDACTED]

Abbreviations: ICER, incremental cost-effectiveness ratio; QALY, quality-adjusted life year.

Figure 22. [REDACTED]



Figure 23. [REDACTED]

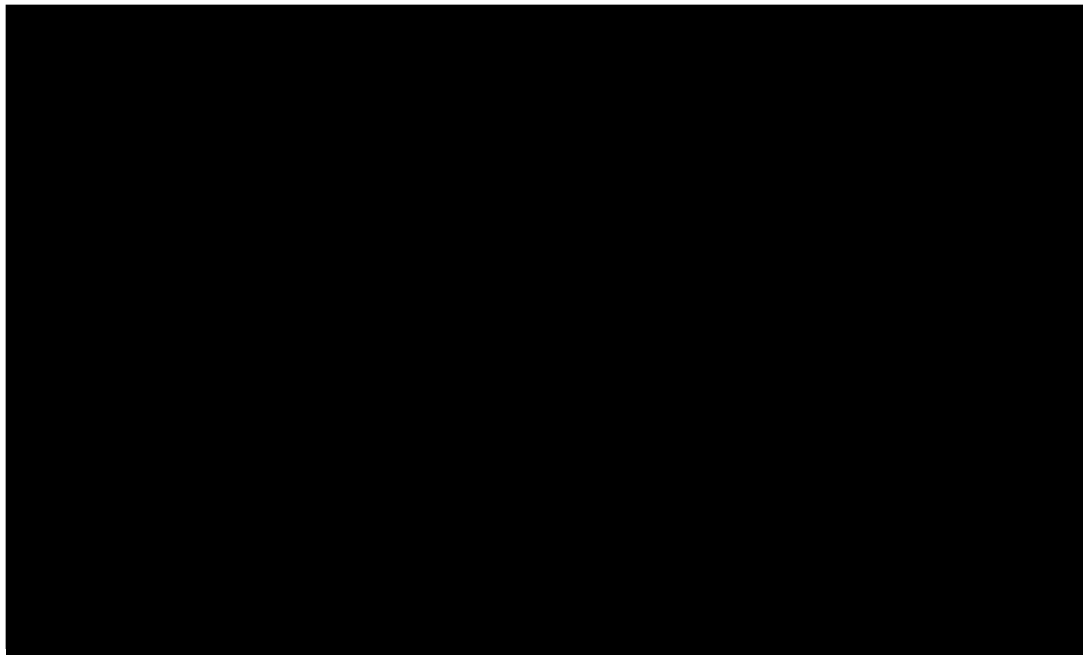

B.3.7.2 Deterministic sensitivity analysis

A series of deterministic sensitivity analyses were performed to evaluate the parameter uncertainty of individual inputs, holding all else constant. Where available, 95% confidence intervals (CIs) were used to inform this range; these were either as reported or calculated based on standard errors or standard deviations and subject numbers. When such information was not available, an arbitrary range of $\pm 15\%$ of the base-case value was used. All parameters described in section B.3.5 were varied. Figure 24 presents a tornado diagram with parameters shown in descending order of impact on the net monetary benefit (NMB). NMB was presented rather than the ICER to allow for results that are not associated with both increased costs and increased QALYs. The NMB is defined as:

$$NMB = \Delta QALYs \lambda - \Delta Costs$$

Where $\Delta Costs$ and $\Delta QALYs$ are the incremental costs and QALYs associated with lenalidomide, respectively, and λ represents the willingness to pay for a QALY; the willingness-to-pay threshold was assumed to be £30,000 per QALY for the UK base-case. A positive NMB indicates that lenalidomide is cost-effective at the willingness-to-pay threshold (conversely, a negative NMB would suggest lenalidomide is not cost-effective at a given willingness-to-pay threshold).

Figure 24. [REDACTED]

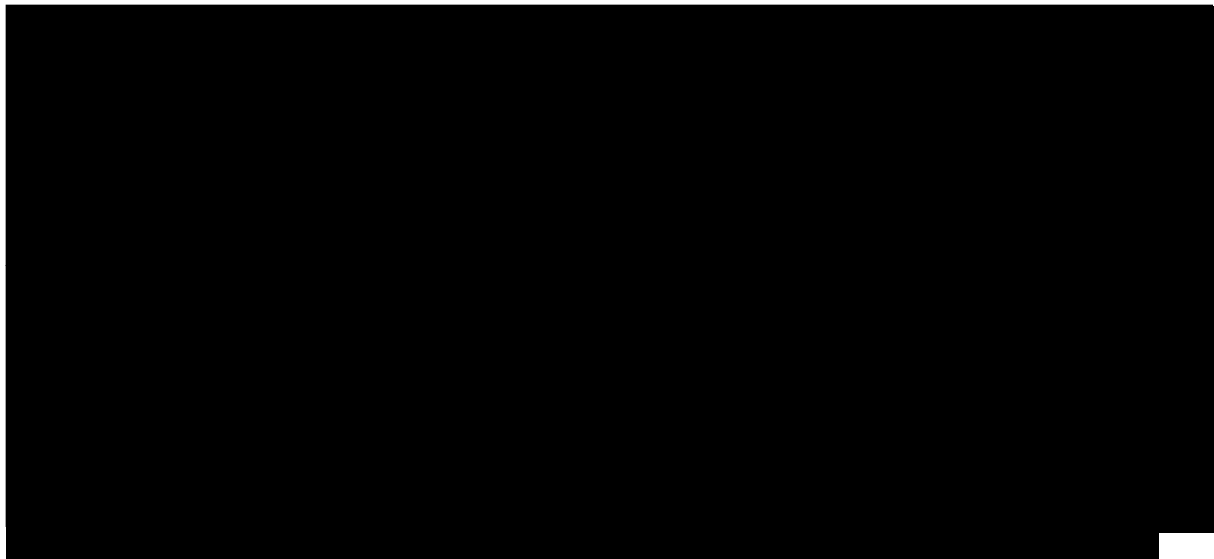

The parameters with the greatest impact on model outcomes relate to [REDACTED]
 [REDACTED]
 [REDACTED]
 [REDACTED]
 [REDACTED]

B.3.7.3 Scenario analysis

The results of scenario analysis results are provided in Table 38. The use of Myeloma XI instead of the UK Clinician Survey provides an ICER [REDACTED]
 [REDACTED] Similarly, a highly conservative scenario in which all subsequent therapy costs are removed from both arms of the model [REDACTED] reflecting the magnitude of QALY gain predicted by extrapolation of results from Myeloma XI (and validated with CALGB 100101).

Table 38. Scenario analysis results

Scenario	Incremental costs	Incremental QALYs	ICER
Base-case	[REDACTED]	[REDACTED]	[REDACTED]
Time horizon: 5 years	[REDACTED]	[REDACTED]	[REDACTED]
Time horizon: 10 years	[REDACTED]	[REDACTED]	[REDACTED]
Time horizon: 20 years	[REDACTED]	[REDACTED]	[REDACTED]
Hatswell utilities	[REDACTED]	[REDACTED]	[REDACTED]

Discount rate: 1.5% benefits, 6% costs			
0% pts receive subsequent therapies			
Include admin costs for oral therapies			
Discount rate for costs: 0%			
Discount rate for costs: 1.5%			
Double AE rates			
Cost of 'Other' treatments is zero			
Cost of 'Other' treatments is doubled			
Apply the post-LOE PAS to the UKCS subsequent treatments in the observation arm			

Abbreviations: AE, adverse event; HR, hazard ratio; ICER, incremental cost-effectiveness ratio; LOE, loss of effectiveness; MRU, medical resource use OS, overall survival; PAS, patient access scheme; PFS, progression-free survival; QALY, quality-adjusted life year; RDI, relative dose intensity; TTD, time-to-discontinuation.

B.3.7.4 Summary of sensitivity analyses results

The analyses indicate the results of the economic evaluation are robust.

Deterministic sensitivity analysis

Probabilistic sensitivity analysis indicated the

model was relatively linear, and lenalidomide was associated

B.3.8 Validation

B.3.8.1 Internal logic

In order to avoid illogical outcomes, rules were applied to:

- Prevent PFS curves crossing OS. If curves did cross, the OS curve was used for both outcomes
- Ensure that the hazards of OS and PFS do not fall below that of the age- and gender-matched general population risk of mortality⁵: when this occurs, the matched general population mortality applies

For greater transparency, the model reports the time point at which the PFS and OS curves would have crossed, had they been permitted to. In the base case, this is

⁵ PFS also contains mortality events therefore require rules to prevent these implied risks falling below that of the general population.

estimated as occurring after 30 years and this was therefore not considered a significant problem within the analysis.

In addition, HRQoL was constrained in probabilistic analysis to ensure that the HRQoL in the progressive disease state did not exceed that of the progression-free state in order to avoid the counterintuitive scenario by which there was a quality of life gain associated with disease progression.

B.3.8.2 Validation of cost-effectiveness analysis

Following completion of programming, the model was validated by external health economists. The following checks were performed on the cost-effectiveness model:

- Review of the analytical approach (checking the overall approach is fit for purpose)
- Cost-effectiveness model logic and calculations (checking the “wiring” of the model for errors)
- Face validity (checking inputs and outputs are sensible and in line with expectation)
- Sheet-by-sheet check (checking for typographical errors, lack of clarity, other miscellaneous comments and suggestions)
- Detailed review of approach to utility values, and subsequent treatment costs

B.3.8.3 Validity of model outputs

A comparison of model outcomes and results reported for Myeloma XI are reported in Table 39. The model results were highly congruent with Myeloma XI with respect to OS. Median PFS was overestimated in both observation and lenalidomide arms of the model. Sensitivity analysis suggests that PFS is not a large determinant of cost-effectiveness in the evaluation (Section B.3.7).

Table 39. Comparison of model outputs and Myeloma XI

	Model outcome		Myeloma XI ¹²³	
	Observation	Lenalidomide	Observation	Lenalidomide
OS at 1 years	96%	98%	95%	97%
OS at 2 years	88%	93%	88%	93%
OS at 3 years	79%	86%	79%	87%
OS at 4 years	68%	80%	71%	79%
Median PFS	3.4	5.1	2.3	4.5
PFS at 1 years	75%	88%	77%	90%
PFS at 2 years	56%	77%	55%	76%
PFS at 3 years	42%	67%	38%	65%
PFS at 4 years	31%	59%	25%	56%

Abbreviations: PFS, progression-free survival; OS, overall survival.

B.3.8.4 Validation of cost-effectiveness analysis

A comparison of the model outputs with other cost-effectiveness analyses shows that estimated life-years and life-years appear similar. Our model predicted [REDACTED] [REDACTED] over a time horizon of 40 years,

Table 40.

Table 40. Validation of cost-effectiveness analysis

Study	Life-years			QALYs		
	Maintenance	Comparator	Incremental	Maintenance	Comparator	Incremental
Olry de Labry Lima 2019 ⁹⁸	7.59	6.58	1.01	CALGB 100101: 5.72 IFM 2005-02: 5.13	4.61 4.98	1.11 0.15
Uyl de Groot 2018 ⁹⁹	9.54	6.76	2.79	8.05	4.79	2.26
Zhou, 2018 ¹⁰⁰	N/a	N/a	3.64	N/a	N/a	2.99
PBAC, 2018	8.50	5.39	3.11	6.52	4.08	2.44
De novo model	[REDACTED]	[REDACTED]	[REDACTED]	[REDACTED]	[REDACTED]	[REDACTED]

Abbreviations: PBAC, Pharmaceutical Benefits Advisory Committee; QALY, quality-adjusted life year.

Compared with the study from Olry de Lima [REF] (using CALGB 100101), [REDACTED] however the direct comparison of the Olry de Lima⁹⁸ outputs with those of our model is not appropriate because of the difference in time-horizon.

Although 10 years is too short to capture all potential benefits of maintenance (approximately 44% of the cohort still alive at 10 years in the Olry De lima⁹⁸ model), an assessment of the outputs of our model at 10 years provides estimates [REDACTED]

[REDACTED]
[REDACTED]
[REDACTED]
[REDACTED] at a 10 years horizon.

It is not possible to determine the reasons [REDACTED] despite the use of a different evidence base. As the study does not provide details for the handling of data from patients who switched from placebo to lenalidomide in CALGB 100101, it is possible that the extrapolation of naïve data may account for [REDACTED] between the two models.

[REDACTED] respect to the estimates reported in PBAC,⁹¹ which used a 25 years-time horizon. When using this time horizon, our model estimates [REDACTED]

[REDACTED] with respect to the PBAC model. When using QALYs, our model estimates [REDACTED]
[REDACTED] compared with the PBAC model

B.3.9 Interpretation and conclusions of economic evidence

Lenalidomide is the first and only treatment that has been found to improve PFS and OS in the maintenance treatment of adult patients with newly diagnosed MM who have undergone ASCT. MM is characterised by regression and remission which ultimately leads to treatment failure. Relapse is the result of the persistence of residual disease which can impair the activity of subsequent lines of therapy. There

is therefore an unmet need to find strategies that could prevent relapse and improve outcomes.

A de novo economic evaluation was conducted to estimate the cost-effectiveness of lenalidomide in this population, with clinical data taken from a subset of patients from the Myeloma XI clinical trial. The economic model is structurally similar to models of lenalidomide in other patient populations and is consistent with other economic evaluations in MM.^{120,130,132,134,136}

Use of a partitioned survival model is considered to capture key aspect of disease. The advantage of such an approach is that the model is defined by commonly reported endpoints and is easy to communicate. The principal disadvantage is that by assuming independence between OS and PFS, dependencies which may impact extrapolation are not considered. For the same reason, sensitivity analysis may become less meaningful (as changes in PFS parameters do not affect OS). The alternative to this approach (a state-transition model) was considered but ultimately not pursued on the basis that the principal data source used to populate the economic evaluation (Myeloma XI) and other studies used for validation have long-term follow-up, permitting reliable post-study extrapolation whilst retaining a simple model structure.

Myeloma XI was considered to be highly representative of the maintenance population of England and Wales; the trial was conducted in the UK and patients received the dosage of 10 mg orally OD on Days 1 to 21 of repeated 28-day cycles, in line with expected clinical practice. The trial demonstrated statistically significant improvements in PFS and OS for people who receive maintenance with lenalidomide. These findings are supported by the findings of other maintenance studies, CALGB 100101, IFM 2005-02.^{3,137}

A further key strength of this analysis is the use of other long-term data sources (specifically, CALGB 100101) to provide data on the long-term expected outcomes for patients who receive basic standard of care and lenalidomide as maintenance; extrapolation of data from Myeloma XI was based on concordance with longer-term data from CALGB 100101.

A key limitation of the analysis includes the reliance on external data sources to estimate QALYs. Whilst the use of external sources adds uncertainty to the model, these parameters were tested in the sensitivity analysis and found to be of limited influence.

The base-case analysis, [REDACTED]

Scenario analyses indicate that [REDACTED]

Another significant driver of results is the source of subsequent therapies. The proportion of patients who received different subsequent therapies after first and second relapse in each arm were informed by a survey of UK clinicians. However, the model also includes a pathway informed by the subsequent treatments received in Myeloma XI, which was not included in the base case as not considered to be reflective of current and future UK clinical practice. A small percentage of patients in Myeloma XI received re-treatment with lenalidomide after receiving maintenance therapy which is unlikely to be representative of use in clinical practice. Additionally, a proportion of patients received treatment regimens that were from the Cancer Drugs Fund and under current circumstances are not part of the multiple myeloma pathway. No patients in Myeloma XI received the combination of daratumumab, bortezomib and dexamethasone because this triplet was unavailable at that time; however, this therapy is expected to be given to the majority of patients, also reflected in the UK clinician survey. As daratumumab, bortezomib and dexamethasone is one of the most expensive treatment regimens, this omission in Myeloma XI may be a source of under-estimation of the cost of subsequent treatments.

Finally, it should be noted that whilst the model estimates the difference in rates of progression between maintenance and observation, it does not distinguish between

post-progression health states and time to progression to further treatment lines; in addition, the same utility is applied after progression regardless of arm. This assumption may not fully capture the incremental benefit of treatment on delaying or avoiding subsequent relapses and slowing the decline in QoL but was made due to an absence of any other data.

In conclusion, these results indicate lenalidomide is a cost-effective use of NHS resources in the maintenance treatment of adult patients with newly diagnosed MM who have undergone ASCT. Therefore, lenalidomide should be recommended for routine clinical practice in the NHS in newly diagnosed people with multiple myeloma who received ASCT.

References

1. European Medicines Agency. Summary of opinion (post authorisation). Revlimid (lenalidomide), January 2016. Available from: https://www.ema.europa.eu/en/documents/smop/chmp-post-authorisation-summary-positive-opinion-revlimid-ii-89g_en.pdf. (Accessed 26 September 2019).
2. Holstein SA, Jung SH, Richardson PG *et al*. Updated analysis of CALGB (Alliance) 100104 assessing lenalidomide versus placebo maintenance after single autologous stem-cell transplantation for multiple myeloma: a randomised, double-blind, phase 3 trial. *Lancet Haematol* 2017;4:e431–e442.
3. Attal M, Lauwers-Cances V, Marit G *et al*. Lenalidomide maintenance after stem-cell transplantation for multiple myeloma. *N Engl J Med* 2012;366:1782–91.
4. McCarthy PL, Owzar K, Hofmeister CC *et al*. Lenalidomide after stem-cell transplantation for multiple myeloma. *N Engl J Med* 2012;366:1770–81.
5. Jackson GH, Davies FE, Pawlyn C *et al*. Lenalidomide maintenance versus observation for patients with newly diagnosed multiple myeloma (Myeloma XI): a multicentre, open-label, randomised, phase 3 trial. *Lancet Oncol* 2019;20:57–73.
6. National Institute for Health and Care Excellence. TA586. Lenalidomide plus dexamethasone for multiple myeloma after 1 treatment with bortezomib, 26 June 2019. Available from: <https://www.nice.org.uk/guidance/ta586>. (Accessed 30 September 2019).
7. National Institute for Health and Care Excellence. TA587. Lenalidomide plus dexamethasone for previously untreated multiple myeloma, 26 June 2019. Available from: <https://www.nice.org.uk/guidance/TA587>. (Accessed 30 September 2019).
8. National Institute for Health and Care Excellence. TA171. Lenalidomide for the treatment of multiple myeloma in people who have received at least one prior therapy, 26 June 2019. Available from: <https://www.nice.org.uk/guidance/ta171> (Accessed 30 September 2019)
9. European Medicines Agency. Revlimid-EPAR. Available at (overview), <https://www.ema.europa.eu/en/medicines/human/EPAR/revlimid> (accessed 14 Feb 2020). Includes Medicine Overview: https://www.ema.europa.eu/en/documents/overview/revlimid-epar-medicine-overview_en.pdf; Risk Management Plan: https://www.ema.europa.eu/en/documents/rmp-summary/revlimid-epar-risk-management-plan-summary_en.pdf and Product Information: https://www.ema.europa.eu/en/documents/product-information/revlimid-epar-product-information_en.pdf
10. Quach H, Ritchie D, Stewart AK *et al*. Mechanism of action of immunomodulatory drugs (IMiDS) in multiple myeloma. *Leukemia* 2010;24:22–32.
11. Fink EC, Ebert BL. The novel mechanism of lenalidomide activity. *Blood* 2015;126:2366–9.
12. Acebes-Huerta A, Huergo-Zapico L, Gonzalez-Rodriguez AP *et al*. Lenalidomide induces immunomodulation in chronic lymphocytic leukemia and enhances antitumor immune responses mediated by NK and CD4 T cells. *BioMed Res Int* 2014;2014:265840.

Company evidence submission template for {ID475}

13. Electronic Medicines Compendium. Revlimid (lenalidomide) Summary of product characteristics, May 2019. Available from: <https://www.medicines.org.uk/emc/medicine/19841>. (Accessed 26 September 2019)
14. Joint Formulary Committee. British National Formulary (online) London: BMJ Group and Pharmaceutical Press <http://www.medicinescomplete.com> (accessed 14 Feb 2020).
15. Hoffbrand AV, Catovsky D, Tuddenham EGD. Postgraduate Haematology (fifth edition), 2005. Available from: <http://download.e-bookshelf.de/download/0000/5972/42/L-G-0000597242-0002362915.pdf> (Accessed 25 October 2017).
16. Morgan GJ, Walker BA, Davies FE. The genetic architecture of multiple myeloma. *Nat Rev Cancer* 2012;12:335–48.
17. Cancer Research UK. Myeloma incidence statistics, 2014–2016. Available from: <https://www.cancerresearchuk.org/health-professional/cancer-statistics/statistics-by-cancer-type/myeloma/incidence#heading-One>. (Accessed 27 September 2019)
18. Haematological Malignancy Research Network. Myeloma 2010–2016. Available from: <https://www.hmrn.org/statistics/disorders/24>. (Accessed 27 September 2019).
19. Cancer Research UK. Myeloma statistics. Available from: <https://www.cancerresearchuk.org/health-professional/cancer-statistics/statistics-by-cancer-type/myeloma>. (Accessed 27 September 2019).
20. Office for National Statistics. Cancer registration statistics, England 2017. Available from: <https://www.ons.gov.uk/peoplepopulationandcommunity/healthandsocialcare/conditionsanddiseases/bulletins/cancerregistrationstatisticsengland/2017> (Accessed 09 December 2019).
21. Welsh Cancer Intelligence and Surveillance Unit. Cancer incidence in Wales, 2001-2017. Available at, https://publichealthwales.shinyapps.io/Cancer_incidence_in_Wales_2001-2017/ (accessed, 21 January, 2020).
22. Cancer Research UK. Myeloma mortality statistics, 2017. Available from: <https://www.cancerresearchuk.org/health-professional/cancer-statistics/statistics-by-cancer-type/myeloma/mortality#heading-Zero>. (Accessed 31 January 2020)
23. Cancer Research UK. Myeloma survival statistics, December 2014. Available from: <https://www.cancerresearchuk.org/health-professional/cancer-statistics/statistics-by-cancer-type/myeloma/survival#heading-Zero>. (Accessed 3 January 2020)
24. Borrello I. Can we change the disease biology of multiple myeloma? *Leuk Res* 2012;36 (suppl 1):S3–12.
25. Bird JM, Owen RG, D'Sa S *et al*. Guidelines for the diagnosis and management of multiple myeloma 2014. Available from: http://www.bcsghguidelines.com/documents/MYELOMA_GUIDELINE_Feb_2014_for_BCSH.pdf (Accessed 25 October 2017).
26. Kumar SK, Therneau TM, Gertz MA *et al*. Clinical course of patients with relapsed multiple myeloma. *Mayo Clin Proc* 2004;79:867–74.
27. Paiva B, Gutierrez NC, Rosinol L *et al*. High-risk cytogenetics and persistent minimal residual disease by multiparameter flow cytometry predict

- unsustained complete response after autologous stem cell transplantation in multiple myeloma. *Blood* 2012;119:687–91.
28. Rawstron AC, Gregory WM, de Tute RM *et al*. Minimal residual disease in myeloma by flow cytometry: independent prediction of survival benefit per log reduction. *Blood* 2015;125:1932–5.
 29. Kumar S, Paiva B, Anderson KC *et al*. International Myeloma Working Group consensus criteria for response and minimal residual disease assessment in multiple myeloma. *Lancet Oncol* 2016;17:e328–e346.
 30. International Myeloma Foundation. Multiple myeloma: concise review of the disease and treatment options, 2016 (2nd Ed). Available from: <https://www.myeloma.org/sites/default/files/images/publications/UnderstandingPDF/concisereview.pdf>. (Accessed 25 October 2017).
 31. Kyle RA, Gertz MA, Witzig TE *et al*. Review of 1027 patients with newly diagnosed multiple myeloma. *Mayo Clin Proc* 2003;78:21–33.
 32. Rajkumar SV, Kumar S. Multiple Myeloma: Diagnosis and Treatment. *Mayo Clin Proc* 2016;91:101–19.
 33. Dimopoulos MA, Sonneveld P, Leung N *et al*. International Myeloma Working Group Recommendations for the Diagnosis and Management of Myeloma-Related Renal Impairment. *J Clin Oncol* 2016;34:1544–57.
 34. Palumbo A, Cavallo F, Gay F *et al*. Autologous transplantation and maintenance therapy in multiple myeloma. *N Engl J Med* 2014;371:895–905.
 35. Durie BG, Salmon SE. A clinical staging system for multiple myeloma. Correlation of measured myeloma cell mass with presenting clinical features, response to treatment, and survival. *Cancer* 1975;36:842–54.
 36. Greipp PR, San Miguel J, Durie BG *et al*. International staging system for multiple myeloma. *J Clin Oncol* 2005;23:3412–20.
 37. Fonseca R, Bergsagel PL, Drach J *et al*. International Myeloma Working Group molecular classification of multiple myeloma: spotlight review. *Leukemia* 2009;23:2210–21.
 38. Shaughnessy JDJ, Haessler J, van Rhee F *et al*. Testing standard and genetic parameters in 220 patients with multiple myeloma with complete data sets: superiority of molecular genetics. *Br J Haematol* 2007;137:530–6.
 39. Palumbo A, Avet-Loiseau H, Oliva S *et al*. Revised International Staging System for Multiple Myeloma: A Report From International Myeloma Working Group. *J Clin Oncol* 2015;33:2863–9.
 40. Hajek R. Strategies for the treatment of multiple myeloma in 2013: moving toward the cure. In: Hajek R, editor. Multiple myeloma – a quick reflection on the fast progress. IntechOpen, 2013. Available from: <http://www.intechopen.com/books/multiple-myeloma-a-quick-reflection-on-the-fast-progress/strategies-for-the-treatment-of-multiple-myeloma-in-2013-moving-toward-the-cure> (Accessed 25 October 2017).
 41. Cook R. Economic and clinical impact of multiple myeloma to managed care. *J Manag Care Pharm* 2008;14:19–25.
 42. Yong K, Delforge M, Driessen C *et al*. Multiple myeloma: patient outcomes in real-world practice. *Br J Haematol* 2016;175:252–64.
 43. Mohty B, El-Cheikh J, Yakoub-Agha I *et al*. Treatment strategies in relapsed and refractory multiple myeloma: a focus on drug sequencing and 'retreatment' approaches in the era of novel agents. *Leukemia* 2012;26:73–85.

44. Hulin C, Hansen T, Laurenson S, Streetly M. A European study of the emotional and physical impact of relapse on patients with multiple myeloma. Abstract presented at the 19th Congress of the European Haematology Association (EHA), 12–15 June 2014, Milan, Italy. Abstract P635.
45. Kurtin S, Lilleby K, Spong J. Caregivers of multiple myeloma survivors. *Clin J Oncol Nurs* 2013;17 (suppl):25–32.
46. Hulin C, Hansen T, Heron L *et al*. Living with the burden of relapse in multiple myeloma from the patient and physician perspective. *Leuk Res* 2017;59:75–84.
47. National Institute for Health and Care Excellence. TA228. Bortezomib and thalidomide for the first-line treatment of multiple myeloma, July 2011. Available from: <https://www.nice.org.uk/Guidance/ta228> (Accessed 25 October 2017).
48. SEER 2014. Available from: <http://seer.cancer.gov/statfacts/>. Accessed: Sept 2016.
49. Moreau P, Attal M, Facon T. Frontline therapy of multiple myeloma. *Blood* 2015;125:3076–84.
50. Moreau P, San Miguel J, Sonneveld P *et al*. Multiple myeloma: ESMO Clinical Practice Guidelines for diagnosis, treatment and follow-up. *Ann Oncol* 2017;28 (suppl 4):iv52–iv61.
51. Market Research. Data on file. Celgene 2016.
52. Raab MS, Cavo M, Delforge M *et al*. Multiple myeloma: practice patterns across Europe. *Br J Haematol* 2016;175:66–76.
53. National Comprehensive Cancer Network. NCCN guidelines 3rd version, 2016. Available from: https://www.nccn.org/professionals/physician_gls/pdf/myeloma.pdf. (Accessed September 2016).
54. Al Hamed R, Bazarbachi AH, Malard F, Harousseau JL, Mohty M. Current status of autologous stem cell transplantation for multiple myeloma. *Blood Cancer J* 2019;9:44.
55. National Institute for Health and Care Excellence. TA311. Bortezomib for induction therapy in multiple myeloma before high-dose chemotherapy and autologous stem cell transplantation ERG report, 23 April 2014. Available from: <https://www.nice.org.uk/Guidance/TA311>. (Accessed 30 September 2019).
56. Paul B, Lipe B, Ocio EM, Usmani SZ. Induction Therapy for Newly Diagnosed Multiple Myeloma. *Am Soc Clin Oncol Educ Book* 2019;39:e176-e186.
57. Mahajan S, Tandon N, Kumar S. The evolution of stem-cell transplantation in multiple myeloma. *Ther Adv Hematol* 2018;9:123–133.
58. British Society of Blood and Marrow Transplantation. 2018 activity by indication and stem source., available at, <http://bsbmt.org/activity/2018/> (accessed, 06 November, 2019).
59. Kumar SK, Rajkumar V, Kyle RA *et al*. Multiple myeloma. *Nat Rev Dis Primers* 2017;3:17046.
60. McCarthy PL, Hahn T. Strategies for induction, autologous hematopoietic stem cell transplantation, consolidation, and maintenance for transplantation-eligible multiple myeloma patients. *Hematology Am Soc Hematol Educ Program* 2013;2013:496–503.
61. Auner HW, Szydlo R, Hoek J *et al*. Trends in autologous hematopoietic cell transplantation for multiple myeloma in Europe: increased use and improved

- outcomes in elderly patients in recent years. *Bone Marrow Transplant* 2015;50:209–15.
62. Wuchter P, Ran D, Bruckner T *et al*. Poor mobilization of hematopoietic stem cells-definitions, incidence, risk factors, and impact on outcome of autologous transplantation. *Biol Blood Marrow Transplant* 2010;16:490–9.
 63. Goker H, Ciftciler R, Demiroglu H *et al*. Predictive factors for stem cell mobilization failure in multiple myeloma patients: a single center experience. *Transfus Apher Sci* 2019:102595.
 64. Larsen JT, Kumar S. Evolving paradigms in the management of multiple myeloma: novel agents and targeted therapies. *Rare Cancers Ther* 2015;3:47–68.
 65. Snowden JA, Saccardi R, Allez M *et al*. Haematopoietic SCT in severe autoimmune diseases: updated guidelines of the European Group for Blood and Marrow Transplantation. *Bone Marrow Transplant* 2012;47:770–90.
 66. Pessoa de Magalhaes RJ, Vidriales MB, Paiva B *et al*. Analysis of the immune system of multiple myeloma patients achieving long-term disease control by multidimensional flow cytometry. *Haematologica* 2013;98:79–86.
 67. Pratt G, Goodyear O, Moss P. Immunodeficiency and immunotherapy in multiple myeloma. *Br J Haematol* 2007;138:563–79.
 68. Roschewski M, Korde N, Wu SP, Landgren O. Pursuing the curative blueprint for early myeloma. *Blood* 2013;122:486–90.
 69. Facon T. Maintenance therapy for multiple myeloma in the era of novel agents. *Hematology Am Soc Hematol Educ Program* 2015;2015:279-85.
 70. Mohty M, Harousseau JL. Treatment of autologous stem cell transplant-eligible multiple myeloma patients: ten questions and answers. *Haematologica* 2014;99:408–16.
 71. Gay F, Jackson G, Rosinol L *et al*. Maintenance Treatment and Survival in Patients With Myeloma: A Systematic Review and Network Meta-analysis. *JAMA Oncol* 2018;4:1389-1397.
 72. Mateos M-V, González-Calle V. Targeted therapy and maintenance in myeloma. *British Medical Bulletin* 2017;122:163-178.
 73. Mateos MV, de la Calle VG. Lenalidomide as maintenance for every newly diagnosed patient with multiple myeloma. *Lancet Oncol* 2019;20:5-6.
 74. National Comprehensive Cancer Network. Multiple myeloma. V1.2020. September 2019, Available from: https://www.nccn.org/professionals/physician_gls/pdf/myeloma.pdf. (Accessed 27 September 2019).
 75. Mikhael J, Ismaila N, Cheung MC *et al*. Treatment of multiple myeloma: ASCO and CCO joint clinical practice guideline. *Journal of Clinical Oncology* 2019;37:1228–63.
 76. NHS England. National Chemotherapy Algorithms (Multiple Myeloma). Available at https://www.engage.england.nhs.uk/consultation/specialised-services-consultation/user_uploads/chemothrpy-algrthms-mltpl-myeloma.pdf (accessed, 04 February 2020).
 77. National Institute for Health and Care Excellence. TA457. Carfilzomib for previously treated multiple myeloma, 19 July 2017. Available from: <https://www.nice.org.uk/guidance/ta457>. (Accessed 30 September 2019).
 78. National Institute for Health and Care Excellence. NG35 (first-line treatment). Myeloma: diagnosis and management. Available from:

- <https://www.nice.org.uk/guidance/ng35/chapter/Recommendations#managing-newly-diagnosed-myeloma> (Accessed 30 September 2019).
79. National Institute for Health and Care Excellence. TA129. Bortezomib monotherapy for relapsed multiple myeloma, 23 October 2007. Available from: <https://www.nice.org.uk/Guidance/ta129>. (Accessed 30 September 2019).
 80. National Institute for Health and Care Excellence. TA573. Daratumumab with bortezomib and dexamethasone for previously treated multiple myeloma, 10 April 2019. Available from: <https://www.nice.org.uk/guidance/ta573>. (Accessed 30 September 2019)
 81. Gay F, Engelhardt M, Terpos E *et al*. From transplant to novel cellular therapies in multiple myeloma: European Myeloma Network guidelines and future perspectives. *Haematologica* 2018;103:197–211.
 82. Snowden JA, Greenfield DM, Bird JM *et al*. Guidelines for screening and management of late and long-term consequences of myeloma and its treatment. *Br J Haematol* 2017;176:888–907.
 83. Attal M, Palumbo A, Holstein SA *et al*. Lenalidomide (LEN) maintenance (MNTC) after high-dose melphalan and autologous stem cell transplant (ASCT) in multiple myeloma (MM): a meta-analysis (MA) of overall survival (OS). *Journal of Clinical Oncology* 2016;34 (suppl 15):8001.
 84. McCarthy PL, Holstein SA, Petrucci MT *et al*. Lenalidomide maintenance after autologous stem-cell transplantation in newly diagnosed multiple myeloma: a meta-analysis. *J Clin Oncol* 2017;35:3279–89.
 85. European Medicines Agency. Revlimid-H-C-717-II-0089-G: EPAR - assessment report - variation. 2017. Available from: https://www.ema.europa.eu/en/documents/variation-report/revlimid-h-c-717-x-0073-g-epar-assessment-report-variation_en.pdf. (Accessed 16 January 2019).
 86. Celgene. Myeloma XI trial patients-level data analysis write-up. 2019 (data on file).
 87. ClinicalTrials.gov. Use of thalidomide, lenalidomide, carfilzomib, bortezomib and vorinostat in the initial treatment of newly diagnosed multiple myeloma (Myeloma XI). 2018. Available from: <https://clinicaltrials.gov/ct2/show/NCT01554852>.
 88. Blade J, Samson D, Reece D *et al*. Criteria for evaluating disease response and progression in patients with multiple myeloma treated by high-dose therapy and haemopoietic stem cell transplantation. Myeloma Subcommittee of the EBMT. European Group for Blood and Marrow Transplant. *Br J Haematol* 1998;102:1115-23.
 89. Durie BG, Harousseau JL, Miguel JS *et al*. International uniform response criteria for multiple myeloma. *Leukemia* 2006;20:1467–73.
 90. Rajkumar SV, Harousseau JL, Durie B *et al*. Consensus recommendations for the uniform reporting of clinical trials: report of the International Myeloma Workshop Consensus Panel 1. *Blood* 2011;117:4691–5.
 91. Pharmaceutical Benefits Advisory Committee (Australia). Lenalidomide. Public Summary Document - March 2018 PBAC meeting. Celgene data on file. 2018.
 92. Stewart KD, Johnston JA, Matza LS *et al*. Preference for pharmaceutical formulation and treatment process attributes. *Patient Prefer Adherence* 2016;10:1385–99.

93. Borner M, Scheithauer W, Twelves C, Maroun J, Wilke H. Answering patients' needs: oral alternatives to intravenous therapy. *Oncologist* 2001;6 Suppl 4:12-6.
94. Ludwig H, Bolejack V, Crowley J *et al.* Survival and years of life lost in different age cohorts of patients with multiple myeloma. *J Clin Oncol* 2010;28:1599–605.
95. Pazdur R. Endpoints for assessing drug activity in clinical trials. *Oncologist* 2008;13 Suppl 2:19–21.
96. Facon T, Dimopoulos MA, Dispenzieri A *et al.* Final analysis of survival outcomes in the phase 3 FIRST trial of up-front treatment for multiple myeloma. *Blood* 2018;131:301-310.
97. Food and Drug Administration. Clinical Trial Endpoints for the Approval of Cancer Drugs and Biologics Guidance for Industry. Available at, <https://www.fda.gov/media/71195/download> (accessed, 6 December 2019). 2018.
98. Olry de Labry Lima A, Gimeno-Ballester V, Ríos Tamayo R *et al.* Cost-effectiveness of lenalidomide maintenance in patients with multiple myeloma who have undergone autologous transplant of hematopoietic progenitor cells. *Bone Marrow Transplantation* 2019;54:1908-1919.
99. Uyl-de Groot CA, Ramsden R, Boersma J, Zweegman S, Dhanasiri S. Lenalidomide As Maintenance Treatment for Patients with Newly Diagnosed Multiple Myeloma Post-Autologous Stem Cell Transplantation: A Pharmacoeconomic Assessment in the Netherlands. *Blood* 2018;132:3555-3555.
100. Zhou Z-Y, Parikh K, Chai X *et al.* Cost-Effectiveness Analysis of Lenalidomide for Maintenance Therapy after Autologous Stem Cell Transplant (ASCT) in Newly Diagnosed Multiple Myeloma (NDMM) Patients: A United States Payer Perspective. *Blood* 2018;132:3535-3535.
101. The Pharmaceutical Benefits Scheme. Lenalidomide: capsule, 5 mg, 10 mg and 15 mg; Revlimid® public summary document (PSD). July 2018 PBAC meeting. Available from <http://www.pbs.gov.au/info/industry/listing/elements/pbac-meetings/psd/2018-03/Lenalidomide-psd-march-2018>. (Accessed 17 February 2020).
102. The Pharmaceutical Benefits Scheme. Lenalidomide: capsule 5 mg, capsule 10 mg, capsule 15 mg, capsule 25 mg; Revlimid® public summary document (PSD). March 2019 PBAC Meeting. Available from: <http://www.pbs.gov.au/info/industry/listing/elements/pbac-meetings/psd/2019-03/lenalidomide-psd-march-2019>. (Accessed 17 February 2020).
103. Dhanasiri S. Response to: Olry de Labry Lima A *et al.*, Cost-effectiveness of lenalidomide maintenance in patients with multiple myeloma who have undergone autologous transplant hematopoietic progenitor cells. *Bone Marrow Transplant* 2019.
104. National Institute for Health and Care Excellence. TA505. Ixazomib with lenalidomide and dexamethasone for treating relapsed or refractory multiple myeloma, 7 February 2019. Available from: <https://www.nice.org.uk/guidance/ta505>. (Accessed 30 September 2019)
105. National Institute for Health and Care Excellence. TA510. Daratumumab monotherapy for treating relapsed and refractory multiple myeloma, 14 March 2018. Available from: <https://www.nice.org.uk/guidance/ta510>. (Accessed 30 September 2019)

106. National Institute for Health and Care Excellence. TA427. Pomalidomide for multiple myeloma previously treated with lenalidomide and bortezomib, 11 January 2017. Available from: <https://www.nice.org.uk/guidance/ta427> (Accessed 30 September 2019).
107. National Institute for Health and Care Excellence. TA380. Panobinostat for treating multiple myeloma after at least 2 previous treatments, 27 January 2016. Available from: <https://www.nice.org.uk/guidance/ta380>. (Accessed 30 September 2019).
108. National Institute for Health and Care Excellence. Guide to the methods of technology appraisal. Available from: <https://www.nice.org.uk/process/pmg9/resources/guide-to-the-methods-of-technology-appraisal-2013-pdf-2007975843781> (Accessed 29 November 2019). 2013.
109. Woods B, Sideris E, Palmer S, Latimer N, Soares M. NICE Decision Support Unit Technical Support Document 19: partitioned survival analysis for decision modelling in Health care: a critical review. Available at, <http://nicedsu.org.uk/wp-content/uploads/2017/06/Partitioned-Survival-Analysis-final-report.pdf> (accessed, 29 Nov 2019). 2017.
110. Woods B, Sideris E, Palmer S, Latimer N, Soares M. NICE Decision Support Unit Technical Support Document 19: partitioned survival analysis for decision modelling in Health care: a critical review. 2017.
111. Acaster S, Gaugris S, Velikova G, Yong K, Lloyd AJ. Impact of the treatment-free interval on health-related quality of life in patients with multiple myeloma: a UK cross-sectional survey. *Support Care Cancer* 2013;21:599–607.
112. <https://github.com/kassambara/survminer>.
113. R Core Team (2017). R: A language and environment for statistical computing. R Foundation for Statistical Computing, Vienna, Austria. URL <https://www.R-project.org/>.
114. Therneau Package ‘survival’ 2019, downloaded from <https://cran.r-project.org/web/packages/survival/survival.pdf>.
115. Decision Support Unit S, University of Sheffield. NICE DSU Technical Support Document 14: Survival analysis for economic evaluations alongside clinical trials - extrapolation with patient-level data. 2013.
116. Akaike H. A new look at the statistical model identification. *Automatic Control, IEEE Transactions on* 1974;19:716-723.
117. Schwarz G. Estimating the Dimension of a Model. *The Annals of Statistics* 1978;6:461-464.
118. National Institute for Health and Care Excellence. Guide to the methods of technology appraisal. 2013.
119. Dolan P. Modeling valuations for EuroQol health states. *Med Care* 1997;35:1095-108.
120. National Institute for Health and Care Excellence. TA510 Daratumumab monotherapy for treating relapsed and refractory multiple myeloma, Committee Papers. 2018.
121. Abonour R, Durie BGM, Jagannath S *et al.* Health-Related Quality of Life of Patients with Newly Diagnosed Multiple Myeloma Receiving Any or Lenalidomide Maintenance after Autologous Stem Cell Transplant in the Connect® MM Disease Registry *Blood* 2016;128:537.

122. Janssen B, Szende A. (2014) Population Norms for the EQ-5D. In: Szende A., Janssen B., Cabases J. (eds) Self-Reported Population Health: An International Perspective based on EQ-5D. Springer, Dordrecht.
123. Celgene Ltd. Data on file: analysis of MYELOMA XI. 2019.
124. The British National Formulary,, 2019. Available from: <https://bnf.nice.org.uk/> (Accessed).
125. National Institute for Health and Care Excellence. TA587 Lenalidomide plus dexamethasone for previously untreated multiple myeloma, Committee papers. 2019.
126. Celgene Ltd. Data on file: clinician resource use questionnaire. 2018.
127. Department of Health and Social Care. National schedule of Reference Costs 2017-18. 2018.
128. Celgene Ltd. Summary of Product Characteristics: Revlimid 2.5 mg Hard Capsules. 2019.
129. Guidance, Drugs and pharmaceutical electronic market information (eMit), 2019. Available from: <https://www.gov.uk/government/publications/drugs-and-pharmaceutical-electronic-market-information-emit> (Accessed 12 October 2019).
130. National Institute for Health and Care Excellence. TA573 Daratumumab with bortezomib and dexamethasone for previously treated multiple myeloma, Committee Papers. 2019.
131. National Institute for Health and Care Excellence. TA586 Lenalidomide plus dexamethasone for multiple myeloma after 1 treatment with bortezomib, Committee papers. 2019.
132. National Institute for Health and Care Excellence. TA505 Ixazomib with lenalidomide and dexamethasone for treating relapsed or refractory multiple myeloma, Committee Papers. 2018.
133. DT-PACE (dexamethasone, thalidomide, cisplatin, doxorubicin, cyclophosphamide and etoposide) for Myeloma from: http://www.londoncanceralliance.nhs.uk/media/51918/MM_DTPACE_Protocol_V1.0.pdf (Accessed).
134. National Institute for Health and Care Excellence. TA427, Pomalidomide for multiple myeloma previously treated with lenalidomide and bortezomib, Committee Papers. 2017.
135. Barton P. The use of modelling to evaluate new drugs for patients with a chronic condition: the case of antibodies against tumour necrosis factor in rheumatoid arthritis. *Health Technology Assessment* 2004;8.
136. National Institute for Health and Care Excellence. TA380, Panobinostat for treating multiple myeloma after at least 2 previous treatments, Committee Papers. 2016.
137. Holstein SA, Jung SH, Richardson PG *et al.* Updated analysis of CALGB (Alliance) 100104 assessing lenalidomide versus placebo maintenance after single autologous stem-cell transplantation for multiple myeloma: a randomised, double-blind, phase 3 trial. *Lancet Haematol* 2017;4:e431-e442.

NATIONAL INSTITUTE FOR HEALTH AND CARE EXCELLENCE

Single technology appraisal

Lenalidomide for the maintenance treatment of multiple myeloma after autologous stem cell transplantation [ID475]

Clarification questions

March 2020

File name	Version	Contains confidential information	Date
Lenalidomide for the maintenance treatment of multiple myeloma after autologous stem cell transplantation (ID475)	1	Yes	20 March 2020

Notes for company

Highlighting in the template

Square brackets and grey highlighting are used in this template to indicate text that should be replaced with your own text or deleted. These are set up as form fields, so to replace the prompt text in [grey highlighting] with your own text, click anywhere within the highlighted text and type. Your text will overwrite the highlighted section.

To delete grey highlighted text, click anywhere within the text and press DELETE.

Section A: Clarification on effectiveness data

Literature searches

A1. Please provide the date when the clinical effectiveness searches were carried out (Appendix E p13).

Searches were carried out the 3rd October 2019

A2. Were any citation chasing methods used for the clinical effectiveness searches? If so, please provide details.

Inclusion and exclusion criteria were applied to the bibliography of McCarthy et al (See Appendix 1 to this document).

A3. Were any searches were carried out in the most current version of Medline (e.g. on PubMed) to update the searches on Embase.com?

Searches were only carried out in Medline and Embase, both searches were run separately on the embase.com platform. We did not carry out separate searches in PubMed.

A4. Were any searches were carried out for adverse events? If so, please describe these.

No searches were carried out for adverse events.

Systematic review methods

A5. Please supply a list of studies excluded during the clinical effectiveness review at title and abstract, with reasons for exclusion.

See attached Excel file "Myeloma_RevisedScreen_Clinical Lit Review_Reconciled"

Dosing

A6. Priority question: Please provide further justification for why the treatment regimen in clinical practice (stated by the company to be a 1-21d regimen) will not be aligned with the SmPC (a 1-28d regimen).

Clinical advice was sought on this assumption. In Myeloma XI, the 1-21day regimen was used because at the time maintenance treatment in the ASCT eligible people was not licensed and 1-21day regimens were the standard in non-ASCT eligible patients. In the future, this schedule will be the preferred option because clinicians are used to treating in this manner. Additional considerations include safety and the need to give patients a rest for one week.

A7. The SmPC for lenalidomide states that dose could be increased to 15 mg after the third cycle if tolerated, but the dosages described in the trial and used in the cost-effectiveness model do not appear to incorporate this. Please confirm

- a) what percentage, if any, of the patients included the presented trial data increased dosage to 15 mg

No patients had an increase in dose to 15mg; in addition, this possibility was not mentioned in the Myeloma XI protocol.

- b) whether this was included in the cost-effectiveness analysis.

The model uses RDI (proportion of average dose / recommended dose of lenalidomide) therefore the 15mg dose was not included in the model.

A8. What is the basis for the company's assertion 'that most patients will not require dose escalation' (CS section B.3.2.3.1)?

We obtained clinical advice on this point.

“There is no evidence dose escalation is of benefit in the maintenance schedule or setting – it is much more important to keep at a dose which has minimal impact on the patient. Some patients are scaled to 5 mg mainly if they have toxicity; particularly haematological or fatigue or diarrhoea – as we know it is duration of therapy in the maintenance setting that is more important than dose”.

A9. Does the company agree that dosage and treatment pathway in CALGB 100104 matches the SmPC and licence indication, even if the dosages used do not correspond to proposed UK practice?

Yes

A10. The company submission (B.3.4.1) states that a relative dose intensity (RDI) estimate was taken from Myeloma XI to reflect the planned versus administered dose of lenalidomide. Please confirm how the adjustment to dose using RDI accounts appropriately for wastage costs, given that lenalidomide is administered orally and is available in packs of 21 (which the ERG assumes is equivalent to the number of capsules typically required for a given treatment cycle).

Myeloma XI data included overall dose intensity for each patient, calculated as a derived variable by trial investigators. This was used for the calculation of RDI.

A11. Please provide the number of patients by cycle who experienced a dose reduction, including what dose was received instead.

The number of people who had a dose reduction on the MXI was 403 (approximately 65%) (Table 1).

Table 1 Lenalidomide dose modification

Reported dose modification	Frequency	Percent	Cumulative Frequency	Cumulative %
Yes	403	64.9	403	64.9
No	190	30.6	593	95.49
Missing	28	4.51	621	100

Trial data

A12 Table 5 of CS Section B, states:

- IFM 2005-002 did not include consolidation therapy
- GIMEMA included consolidation therapy.

Both of these statements are contradicted in section B.2.1.1.3. Please clarify whether table 5 or section B.2.1.1.3 is correct.

We would like to apologise for the confusion caused here. Attal et al (2012) (IFM) includes consolidation treatment: “After undergoing transplantation, patients were randomly assigned in a 1:1 ratio to receive either consolidation treatment with lenalidomide (at a dose of 25 mg per day, on days 1 to 21 of each 28-day cycle, for two cycles), followed by maintenance therapy with lenalidomide (10 mg per day for the first 3 months, increased to 15 mg if tolerated), or the same consolidation treatment with lenalidomide, followed by maintenance therapy with placebo” .

Palumbo et al (2014) (GIMEMA) included consolidation followed by ASCT or no ASCT: “ The consolidation regimen consisted of six 28-day cycles of melphalan (at a dose of 0.18 mg per kilogram of body weight on days 1 through 4), prednisone (2 mg per kilogram on days 1 through 4), and lenalidomide (10 mg on days 1 through 21), or two 4-month cycles of melphalan at a dose of 200 mg per square meter of body-surface area followed by autologous stem cell transplantation”.

The two studies use the same term “consolidation” to identify different treatments. For GIMEMA, “consolidation” (i.e. induction) in people that do not receive ASCT; for IFM: consolidation after ASCT given to all patients regardless of ASCT outcome. Here below is Table 5, updated. Therefore, only IFM has a ‘consolidation’ element proper, whilst GIMEMA uses ‘consolidation’ as an alternative (randomised) treatment to ASCT. We have amended Table 5 as per below.

Table 5. Comparison of CALGB 100104, IFM 2005-02, GIMEMA and Myeloma XI.

	CALGB 100104	IFM 2005-02	GIMEMA	Myeloma XI
UK patients as proportion of study (%)	0 ^a	0 ^a	0 ^a	100

Study powered for detecting survival difference?	No	No	No	Yes ^b
Patient cross-over before PD allowed ^c	Yes	No	No	No
Early discontinuation	No	Yes ^d	No	No
Lenalidomide dose cycle ^e	1–28 of a 28-day cycle	1–28 of a 28-day cycle	1–21 of a 28-day cycle	1–21 of a 28-day cycle
Consolidation therapy (non-UK practice) ^f	No	Yes	No	No

A13. Priority question: Please provide background characteristics for the subgroup of the Myeloma XI population relevant to the decision problem in respect of

- induction regimen
- proportion considered for intensification therapy and proportion randomised to intensification therapy as a subset of this
- distribution of complete response, very good partial response, partial response or minimal response at randomisation stage 3.

Please provide these by arm and overall.

The number of people allocated to induction, by induction regimen, is reported in Table 2 here below.

Table 2 Intensification allocation

Randomisation 1	Frequency	Percent	Cumulative frequency	Cumulative Percent
CTD	317	30.72	317	30.72
CRD	364	35.27	681	65.99
KCRD	351	34.01	1032	100

Key: CTD, attenuated cyclophosphamide, thalidomide, and dexamethasone; CRD, cyclophosphamide, thalidomide, and dexamethasone; KCRD, carfilzomib, cyclophosphamide, lenalidomide and dexamethasone

Distribution of response at the end of induction is reported in Table 3. Only people who reported partial or minimal response (PR, MR) were considered for

randomisation to intensification (n=174); of these, 132 were randomised to VCD or no VCD (Table 4).

Table 3 Distribution of response at randomisation 2.

Response after induction	Frequency	Percent	Cumulative Frequency	Cumulative %
CR or VGPR	831	80.52	831	80.52
PR or MR	174	16.86	1005	97.38
NC or PD	7	0.68	1012	98.06
Unable to assess	6	0.58	1018	98.64
Missing	14	1.36	1032	100

Key: CR: complete response; VGPR: very good partial response; PR: partial response; MR: minimal response; PD: progressive disease

Table 4 Proportion of people randomised to intensification

Randomisation to intensification	Frequency	Percent	Cumulative frequency	Cumulative percent
No intensification therapy	63	47.73	63	47.73
VCD intensification therapy	69	52.27	132	100

Key: VCD: bortezomib, cyclophosphamide, dexamethasone

A14. Please provide tests of the proportional hazards assumption to justify use of a Cox regression for overall survival (OS) and progression free survival (PFS).

Overall survival

Figure 1 displays the log cumulative hazard (LCH) plot for overall survival (OS) in Myeloma XI. The LCH plot appears to be approximately parallel throughout supporting the proportional hazards assumption. Similarly, the Schoenfeld residual plot (Figure 2) produces a line which is approximately horizontal, suggesting that the hazard ratio between treatments does not change over time and the proportional hazards assumption is supported for OS, this is also reflected in the Schoenfeld individual test which suggests there is insufficient evidence to suggest that the proportional hazards assumption is violated (p-value 0.653) during the observed trial period.

Figure 1 Log cumulative hazard plot for overall survival (Myeloma XI)

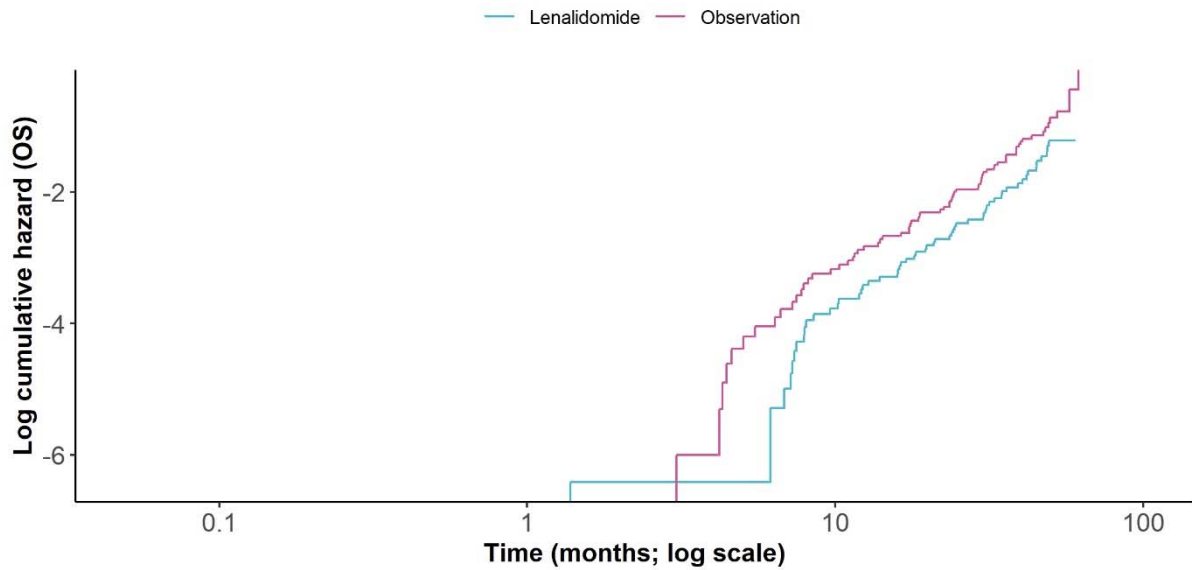

Key: OS, overall survival.

Figure 2 Schoenfeld residual plot for overall survival (Myeloma XI)

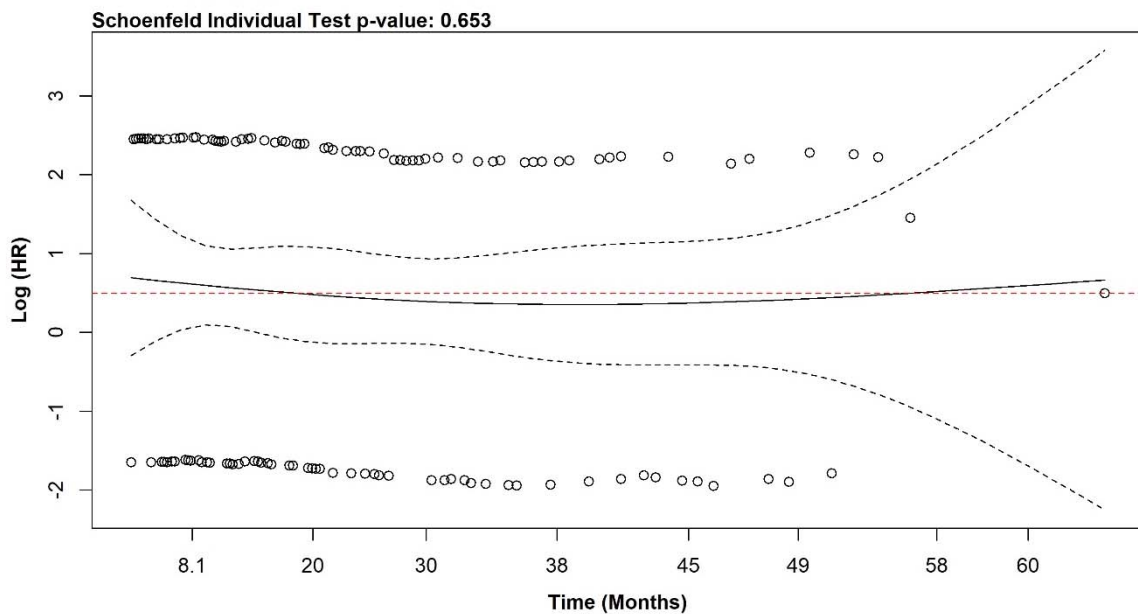

Key: HR, hazard ratio.

Notes: Black solid line indicates time-varying log hazard ratio. Dashed red line indicates constant log hazard ratio.

Progression-free survival

Figure 3 displays the log cumulative hazard (LCH) plot for progression-free survival (PFS) in Myeloma XI. The LCH plot appears to be approximately parallel throughout supporting the proportional hazards assumption. Similarly, the Schoenfeld residual plot (Figure 4) produces a line which is approximately horizontal, suggesting that the

hazard ratio between treatments does not change over time and the proportional hazards assumption is supported for PFS, this is also reflected in the Schoenfeld individual test which suggests there is insufficient evidence to suggest that the proportional hazards assumption is violated (p-value: 0.962).

Figure 3 Log cumulative hazard plot for overall survival by maintenance treatment (Myeloma XI)

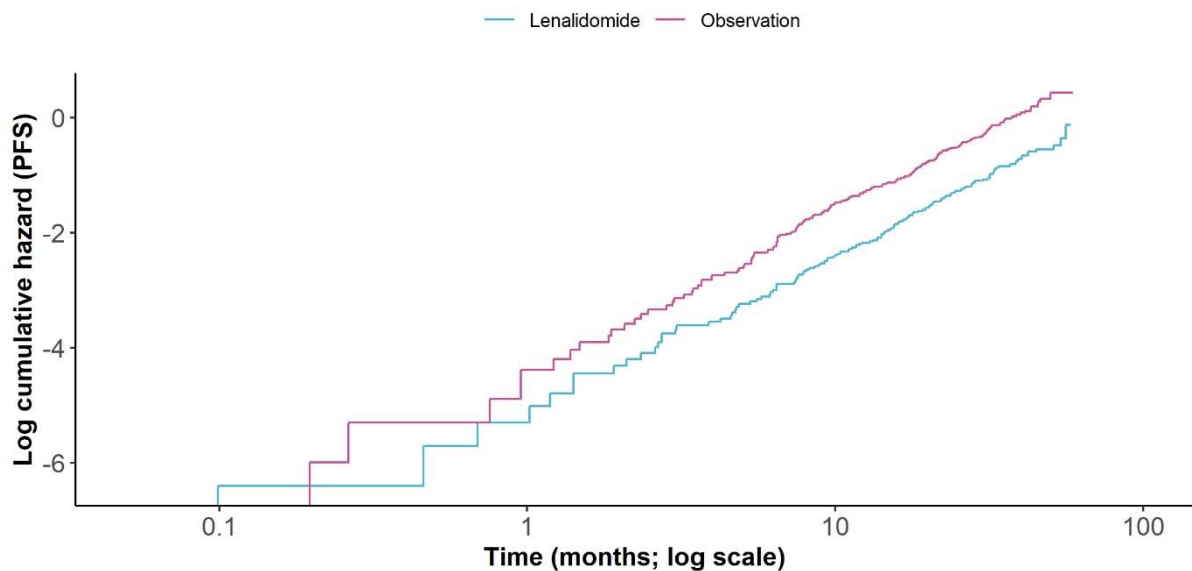
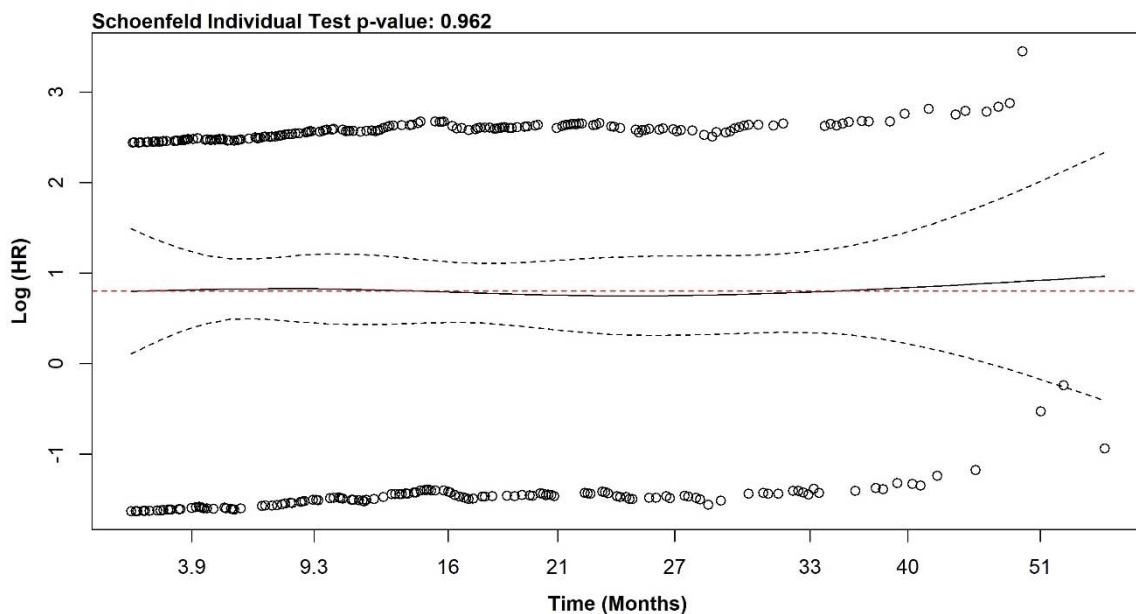

Figure 4 Schoenfeld residual plot for progression-free survival (Myeloma XI)



Key: HR, hazard ratio.

Notes: Black solid line indicates time-varying log hazard ratio. Dashed red line indicates constant log hazard ratio.

A15. Please clarify why PFS2 (progression free survival on the 1st subsequent treatment after the study drug) analyses were not available for the subgroup of the Myeloma XI population relevant to the decision problem. If available for the CALGB 100104 trial, please provide PFS2 analyses.

In Myeloma XI, PFS2 was defined as the time from maintenance randomisation to the date of second PD, or start of third anti-myeloma treatment, or death from any cause. The definition in the question relates to second PFS not PFS2.

Figure 5 and

Figure 6 present the PFS2 KM curve and summary statistics respectively, for the Myeloma XI study by maintenance treatment. The KM shows little difference between treatments up until 12 months, after which patients treated with lenalidomide have improved PFS2 compared to observation.

Figure 5 Kaplan–Meier of second progression-free survival by maintenance treatment (Myeloma XI)

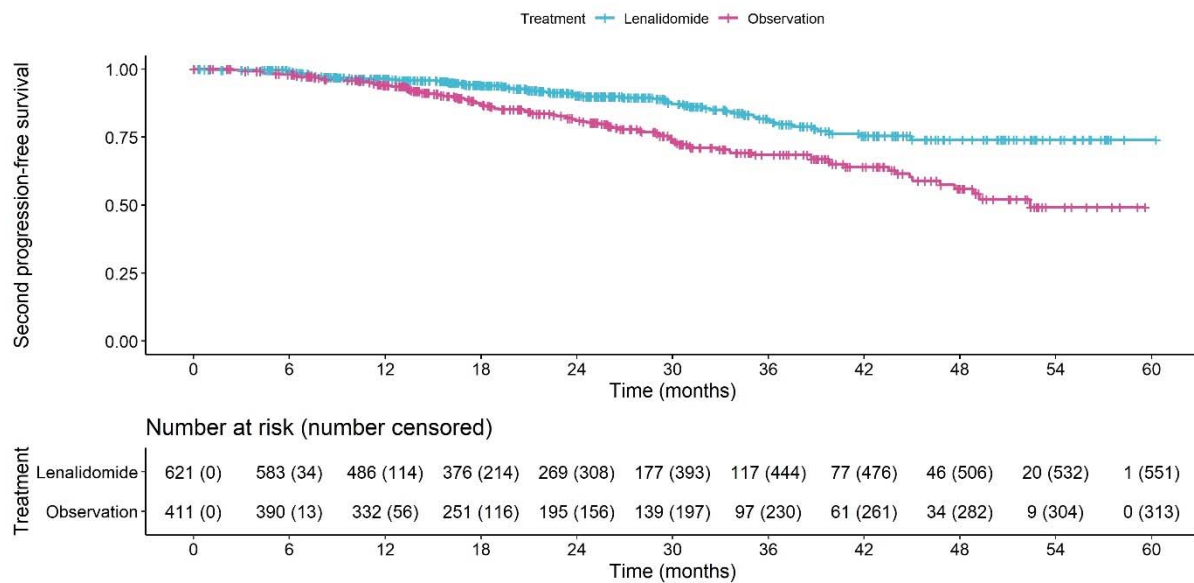

Table 5 presents progression free survival after the first treatment after study drug, i.e. summary statistics for second PFS. The Myeloma XI data is highly immature to provide a meaningful comparison, although the analysis provides a statistically significant difference.

Table 5 Second progression-free survival summary statistics by maintenance treatment (Myeloma XI)

Treatment	n	Events	Censored	Median (months; 95% CI)	HR (95% CI)
Lenalidomide	621	69 (11.1%)	552 (88.9%)	NR (NR, NR)	0.50 (0.37, 0.68)
Observation	411	98 (23.8%)	313 (76.2%)	52.4 (46.8, NR)	
Key: CI, confidence interval, HR, hazard ratio; NA, not applicable; NR, not reached.					

A16. Please confirm if analysis of the subgroup of the Myeloma XI population relevant to the decision problem was a pre-planned analysis.

No, it was not.

A17. Please clarify if the subgroup analysis (subgroup of the Myeloma XI population relevant to the decision problem) ultimately met the described power calculations in CS Appendix M Section M.5.3 for maintenance therapy, or if any power calculations were undertaken specific to this subgroup.

No power calculations were undertaken for the subgroup analysis. However, the reanalysis of the subgroup shows statistically significant results for the primary endpoints (PFS and OS, B2.6.1. in Document B), therefore in agreement with the overall ASCT group power calculations.

A18. Priority question: Figures for treatment discontinuation appear to differ between B.3.2.6 and Appendix O. For clarity, please provide a full account of discontinuation, including:

- How many patients were known to still be receiving treatment at the database lock used for this analysis
- How many patients discontinued treatment with complete data (i.e. a treatment cessation date is known); and of these, how many discontinued due to progression or death or due to another reason
- How many patients fulfilled neither of the above and thus required imputation or censoring.

A total of 377 patients were censored in the TOT analysis. Of these, 365 patients had a reported start and end times and did not report a reason for treatment discontinuation and were assumed to be still on treatment.

In addition, one patient had a missing treatment end time and 11 patients had missing treatment information but were recorded in the safety set. The patient with the missing end time was censored for PFS prior to their treatment end time, this patient was therefore censored for treatment on their PFS time and assumed to still be receiving treatment at this time. The remaining 11 patients were censored on day 1 as their inclusion in the safety set indicates they started treatment however the duration is unknown.

Of 582 patients in the safety set, 566 patients had treatment start and end times. Of 566, 372 patients did not have a reason for treatment discontinuation date, of which 7 patients had a PFS event prior to stopping treatment and were assumed to have stopped treatment due to progression or death. Table 6 provides a summary of the reasons for treatment discontinuation for patients who had reported treatment start and end times.

Table 6 Reasons for treatment discontinuation – patients with treatment start and end times

Reason	Number of patients
Clinical decision	10
Disease progression	99
Death	5
Non-compliance	1
Other	14
Participant choice	16
Secondary malignancy	2
Unacceptable toxicity	54
Not reported (assumed to be still on treatment)	365

365 patients had a treatment start and end time but did not report a reason for treatment discontinuation and were assumed to still be on treatment and censored for the analysis.

16 patients had missing information and required additional imputation.

- Five patients had a missing treatment end date, but had a treatment start date:
 - Four patients had a reason for treatment discontinuation: For these patients, an event was imputed at their PFS date. According to the protocol, patients should discontinue treatment at progression; given it is known that the patients discontinued treatment, the patients PFS date should be the latest possible time at which the patient discontinued treatment
 - One patient did not have a reason for treatment discontinuation: For this patient, it cannot be assumed that the patient discontinued treatment prior to their PFS date given that they do not have a reason for discontinuation; given the patient had not progressed, it was assumed that the patient was still receiving treatment at their PFS date. This patient was therefore censored for TOT on their PFS date
- Eleven patients had missing treatment data: blank cells were reported for treatment start date, treatment end date, number of maintenance cycles received, and dosage received. Given these patients were in the safety set, it was assumed that the patients received treatment, but the duration was unknown; as such, these patients were censored on Day 1.

16 patients therefore had their treatment start/end date imputed, and a total of 377 patients were censored in the analysis.

Post-progression treatment

A19. Please clarify the statement at the bottom of CS Section B p 91:

[REDACTED]

[REDACTED]

[REDACTED]

[REDACTED]

[REDACTED]

[REDACTED]

A20. In Section B.3.4.4, it is stated that '[REDACTED]'. To what degree does that reflect information from the subgroup of the Myeloma XI population relevant to the decision problem included in this submission?

The list of treatments included was taken from the list of therapies from Myeloma XI population relevant for the decision problem. Therapies that were either not evaluable (missing) or which could not be readily costed in the economic model (novel therapies) were excluded (2 cases). Of the remaining therapies, three recorded subsequent therapy types were excluded from the costing:

- 'Supportive care - i.e. not directly for disease' (n=3)
- 'Non-myeloma treatment' (n=2)
- 'Radiotherapy' (n=10).

Radiotherapy and supportive care were excluded on the basis that estimates of medical resource use also include these components; therefore, they represent double counting. Non-myeloma treatments are not part of the decision problem.

Of patients in the relevant Myeloma XI subgroup who have experienced a second progression, how many have received treatment? How many patients that experienced a second PFS event did not receive further treatment because the second PFS event was a death?

The number of people who experiences PFS1, PFS2 and subsequent treatments are described in Table 7. In total 62 patients (23 Lenalidomide and 39 observation) second progression event was a death (using the PFS2 definition in Myeloma XI [time starting from randomisation]).

Table 7 People with progression or death, number of people with treatment after progression

	Len	Obs	Total
Total patients	[REDACTED]	[REDACTED]	[REDACTED]
Patients with PFS1 event	[REDACTED]	[REDACTED]	[REDACTED]

Patients with death PFS1 event	██████	██████	██████
Patients with progression PFS1 event	██████	██████	██████
Patients started subsequent therapy for 1st relapse	██████	██████	██████
Patients with PFS2 event	██████	██████	██████
Patients with death PFS2 event	██████	██████	██████
Patients with progression PFS2 event	██████	██████	██████
Patients started subsequent therapy for 2nd relapse after or on PFS2	██████	██████	██████
Note: §, one patient was marked for receiving treatment for 2 nd relapse but was marked as no event for 2 nd progression. This patient was recorded as progressed for PFS1, and there is no data on subsequent therapy start or end time. The subsequent therapy recorded as given was Lenalidomide (either alone or in combination). *Including missing values			

On review of the patient-level data from the model cohort in Myeloma XI, it has been identified that the 100%, and 77% figures have been previously interpreted as proportion of people to which subsequent therapy costs is applied. These in fact represent the number of lines of therapy received in people experiencing events and are used in the economic model to scale costs of subsequent therapy. 100% (1.00) was the number of treatment lines received as a proportion of people with a PFS1 event (including deaths). The estimate of 77% was similarly simply calculated as number of lines of therapy received (not patients) divided by the number of PFS2 events which occurred. These estimates have now been updated to exclude the 8 deaths in PFS1, assigning a factor subsequent therapy to 1.00 and 0.79 for first and second relapse, respectively.

For the basecase with UK physicians' subsequent therapies, this approach is not possible; in addition, the survey asked physicians to state the % of people who would not receive treatment. Therefore, the UK physician survey data applies to first and second progressions only, excluding the number of deaths from PFS1 and PFS2 counts (so conditional probabilities). The proportion of first progressions is 98% of PFS1 and the proportion of second progressions is 60% of PFS1 (number of PFS2 events, excluding deaths, over the number of PFS1 events).

A21. In a sensitivity analysis, data from Myeloma XI are used for the breakdown of post progression treatments; however, these do not sum to 100% even though this table includes options for “no treatment” or “other” (see Appendix P, Table 65).

Please clarify why the total use of subsequent therapies does not sum to 100% for the Myeloma XI trial, and if appropriate provide updated figures that sum to 100%.

In A20 we provided a rationale why the cost of subsequent therapies was applied as a 'one off' and not as a cost to people that had a progression event. As Myeloma XI had reasonably long follow-up for PFS1, treatments received after progression 1 were considered representative of treatments in the trial at the time. Because we used the cost of all treatment courses received, the cost for people who did not receive any treatment was 0, and their number was added to the denominator of total people to calculate the average cost of post-progression 1 treatment.

A22. The economic model assumes all deaths occur after disease progression (see Section B for further requests for clarification). Please provide the probability of death in Myeloma XI by progression status, estimates of time to progression or relapse and accompanying hazard ratios as prescribed in the decision problem.

The probability of death and HR for pre-progression and post-progression deaths are reported in Table 8 and Table 9 below.

Table 8 Pre-progression survival summary statistics by maintenance treatment (Myeloma XI)

Treatment	n	Events	Censored	Median (months; 95% CI)	HR (95% CI)
Lenalidomide	██████	██████	██████	██████	██████
Observation	██████	██████	██████	██████	
Key: CI, confidence interval, HR, hazard ratio; NA, not applicable; NR, not reached.					

Table 9 Post-progression survival summary statistics by maintenance treatment (Myeloma XI)

Treatment	n	Events	Censored	Median (months; 95% CI)	HR (95% CI)
Lenalidomide	██████	██████	██████	██████	██████
Observation	██████	██████	██████	██████	
Key: CI, confidence interval, HR, hazard ratio; NA, not applicable; NR, not reached.					

Because of low numbers of pre-progression deaths, time to progression is very similar to PFS (Table 10 and Table 15 B.2.6.1. and B.2.6.2. in Document B).

- Inclusion of CALGB parametric survival model (see B13)
- Correction of the 'reset to base-case' button (see B16)

During review, an error in the electronic model was also identified in the calculation of the percentage of patients randomised to receive lenalidomide in the Myeloma XI cohort who received treatment. This was corrected in cell K6 of the engine sheets in order to align the analysis with that described in the Section B.3.2.6 of Document B.

The model was further revised in order to include the age and gender distribution of the Myeloma XI model cohort (59 years and 38% female, respectively), rather than that of the overall Myeloma XI cohort, as had been included previously; we consider this an omission in the original submission, please accept our apologies for this. The effect on the base case is detailed in Table 12. Full results based on the revised base case are reported in the revised version of Document B.

Table 12 Base case results after the removal of CDF treatments

Base case	Incremental costs	Incremental QALYs	ICER
Submitted base case	██████████	██████████	██████████
Revised base case (excluding CDF treatments)	██████████	██████████	██████████

Key: CDF, Cancer Drugs Fund; ICER, incremental cost-effectiveness ratio; QALY, quality-adjusted life year.

Literature searches

B2. Please confirm what platform (e.g. Ovid) was used for the Embase searches for cost effectiveness (Appendix G p45).

The Ovid platform was used throughout.

B3. Please confirm what platform (e.g. Ovid) was used for the Embase searches for health-related quality of life (Appendix H p60).

The Ovid platform was used throughout.

B4. Please confirm what platform (e.g. Ovid) was used for the Embase searches for cost identification (Appendix I p74).

The Ovid platform was used throughout.

Review methods

B5. Please supply a list of studies excluded during the cost effectiveness review at title and abstract, with reasons

B6. The PRISMA diagram for health-related quality of life does not tally:

- the studies excluded at title/abstract adds to 2,312 (921+656+557+177+1) not 2,252 as reported for the total number excluded for that step in the PRISMA. The total excluded of 2,252, however, does tally in context of the rest of the PRISMA.
- the list of studies excluded at full text provided in Table 31 does not appear to tally with the numbers reported in the PRISMA (“Publications excluded at full text review” n=97 in the PRISMA while the number of excluded studies reported in Table 31 is 52)

please supply a revised version (Figure 8, Appendix H, p68).

Full list of studies included and excluded at full text supplied (Appendix 2)

Updated PRISMA diagram added (Appendix 3). A typo was found: the original number of conference and abstracts was erroneous, 177, whilst it should be 117.

Model structure

B7. Priority question: The company has used a partitioned-survival analysis (PartSA) model comprised of three health states to inform its submission. While the precedence for this structural approach in cancer models and in other economic evaluations in MM is acknowledged, there are limitations in the approach in respect to the population within the scope of this appraisal (I.e. maintenance for MM patients who have had prior ASCT). Most notably, the “progressed” state encompasses several lines of subsequent treatment, yet there are no further drops in utility, and costs are applied based on a range of assumptions not directly linked to the time spent in progressed disease. Please clarify the rationale for the structural approach taken in respect of these limitations.

We acknowledge that the PartSA approach is associated with limitations, including those identified in the question. Regarding the observation that the “progressed”

state encompasses several lines of subsequent treatment, yet there are no further drops in utility, this was considered a conservative assumption as lenalidomide delays progression.

An alternative approach would have been the use of a multi-state model, which would explicitly model the transitions between health states. In principle this could allow formal modelling of post-progression survival and potentially the exploration of different subsequent therapy assumptions.

The principal reason that a multi-state model was not pursued was that there were very few events available to estimate the transition from progression-free to death (Question B10) offering no data for the estimation of transition probabilities from pre-progression to death, and requiring the assumption that all post-progression deaths would be considered equal by arm given the lack of demonstration of difference in post-progression deaths by arm, and very immature data for PFS2 (Question B10). Extrapolation based on primary and secondary endpoints of OS and PFS from Myeloma XI was therefore preferred because more robust and because of the ability to validate extrapolations using the CALGB data.

Other reasons for preferring the PartSA approach included:

- A four-state model would be required to apply significantly different assumptions for therapies following second relapse (B8). We believe this limitation referred to in the question is related more to the structure (3-state) than the implementation (PartSA).
- A Markov state-transition model lends itself less well to the incorporation on functional forms other than the exponential to model survival, as it has no memory. Resorting to Markov traces based on statistical software does not overcome the limitations identified by the question.

The main challenge to estimating a multi-state model is determining goodness-of-fit. As the predictions made by the economic model are dependent on statistical modelling of endpoints, choosing best fitting statistical models for each conditional outcome may not produce an analysis which best predicts the study outcomes.¹

There is therefore some ambiguity regarding model selection in this context, which can be avoided using a PartSa approach.

B8. Priority question: The company has highlighted four publications in its review of previous economic evaluations for maintenance therapy in MM. One of these (Olry de Labry Lima et al., 2019) concerns the use of a 4-state PartSA model, with states defined as progression-free, progressed (1st relapse), progressed (2nd relapse), and dead. Please explain why this model structure was not used.

A four-state model including PFS2 to inform a “progressed (2nd relapse)” state would be possible to estimate based on PFS2 in Myeloma XI. Although Myeloma XI provides relatively long-term follow-up, the data with respect to PFS2 are not mature. There was concern that extrapolation based on PFS2 would be unreliable, as these data could not be validated using CALGB. A simple approach in which the cost of subsequent therapies following second relapse was applied following first relapse was preferred. The accompanying assumption that no further drops in utility are experienced after second relapse was considered a conservative assumption as lenalidomide delays progression.

B9. Priority question: In the company’s model, the cost of subsequent therapy is linked to health state occupancy using an instantaneous discounting formula. This approach assigns the costs for post-progression therapy as a lump sum upon (assumed) entry to the progressed state within the model. Such an approach requires the assumed proportion of PFS events that are progressions, and implicitly means that extended occupancy in the progressed disease state is not linked to additional drug costs. An alternative approach which does not require the same explicit assumption to be made would be to assign a cost per model cycle for all patients in the progressed disease state. Please provide a sensitivity analysis using this suggested alternative approach to applying post-progression treatment costs within the model.

As suggested by the reviewers, two alternative approaches to the calculation of the cost of subsequent therapies are now included in the revised model.

The first approach uses a cost per model cycle for subsequent therapies based on the distribution of subsequent therapies. The weighted average of cost per cycle for each regimen, weighted by the distribution of subsequent therapies for first and

second relapse was estimated and aggregated to create a total cost per cycle (different for maintenance and observation because of therapies mix). The aggregated cost per cycle was then applied to patients in the progressed state. This approach does not account for differences in the duration of subsequent therapies.

The second approach attempts to account for the differing treatment duration of each of the subsequent therapies, assigning a cycle cost proportional to (effective) duration of therapies (B3.4.4 of Document B). The cost per cycle is then taken as the average across all such cycles. These calculations are detailed in the electronic model. The impact on results is illustrated in Table 13, based on the revised base-case. In general, the use of a cost per cycle leads to greater cost savings for lenalidomide. This may be because the time spent post-progression is on average greater than the duration of treatment assumed for subsequent therapies.

Table 13 Alternative subsequent therapy calculations

Assumption	Incremental costs	Incremental QALYs	ICER
Revised base case	██████████	██████████	██████████
Cost per cycle	██████████	██████████	██████████
Cost per cycle adjusting for treatment duration	██████████	██████████	██████████

Key: ICER, incremental cost-effectiveness ratio; QALY, quality-adjusted life year.

Extrapolation

B10. Priority question: Please provide Kaplan Meier data from Myeloma XI and associated parametric survival extrapolations for the following additional outcomes:

- Time-to-progression (TTP, defined as the time between randomisation and progressed disease, with death events censored)
- Pre-progression survival (PrePS, defined as the time between randomisation and death prior to progression, with progression events censored)
- Post-progression survival (PostPS, defined as the time between documented disease progression and death)
- Time to progression

Figure 6 and

Table 14 present the time to progression (TTP) KM and the summary statistics respectively, for the Myeloma XI study by maintenance treatment. The KM shows that patients treated with lenalidomide have consistently longer TTP compared with observation across the full observation period. This is also reflected in the summary statistics, where patients treated with lenalidomide had a longer median TTP and a significantly lower rate of events compared with observation (hazard ratio [HR]: 0.44 [95% CI: 0.35, 0.55]). It should be noted that the estimated median PFS for lenalidomide (55.9 months) is uncertain as few patients are at risk when the median is reached.

Figure 6 Kaplan–Meier of time to progression by maintenance treatment (Myeloma XI)

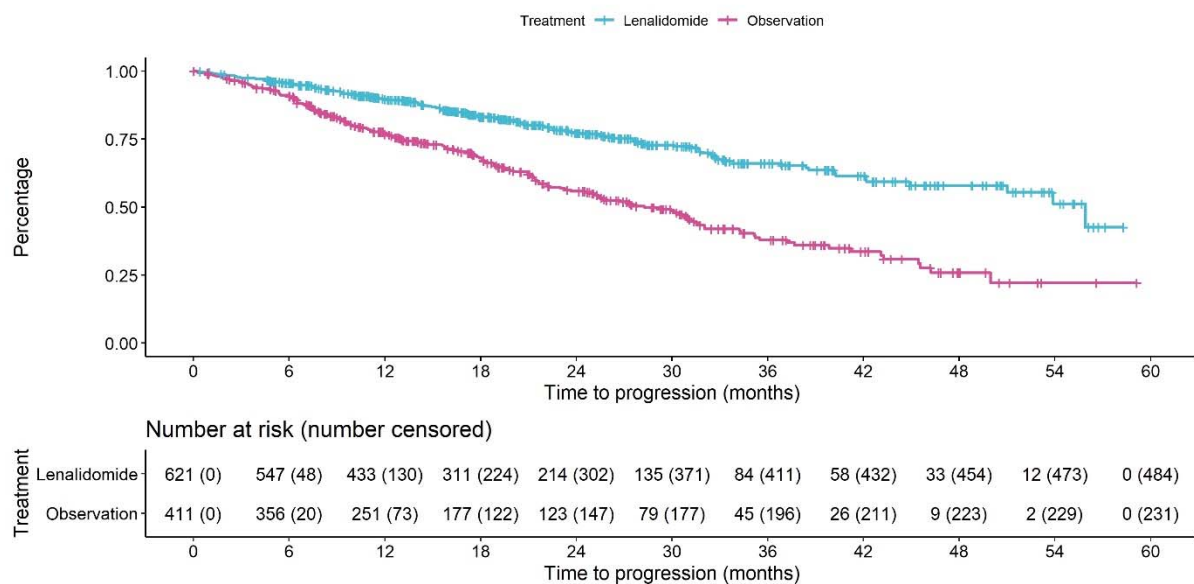

Table 14 Time to progression summary statistics by maintenance treatment (Myeloma XI)

Treatment	n	Events	Censored	Median (months; 95% CI)	HR (95% CI)
Lenalidomide	621	137 (22.1%)	484 (77.9%)	55.9 (51.0, NR)	0.44 (0.35, 0.55)
Observation	411	180 (43.8%)	231 (56.2%)	28.3 (24.6, 32.0)	

Key: CI, confidence interval, HR, hazard ratio; NA, not applicable; NR, not reached.

To determine whether it was appropriate to fit combined models (models fit with a treatment covariate), the PH and AFT assumptions were assessed. The PH assumption was deemed appropriate based on the log-cumulative hazard plot (Figure 7) in which the curves for each treatment are parallel throughout the follow-up (other than a minor deviation in the first month). The AFT assumption was also

deemed appropriate as the points on the quantile-quantile plot (Figure 8) form an approximately straight line. As such, only combined models are presented below.

Figure 7 Log cumulative hazard plot for time to progression by maintenance treatment (Myeloma XI)

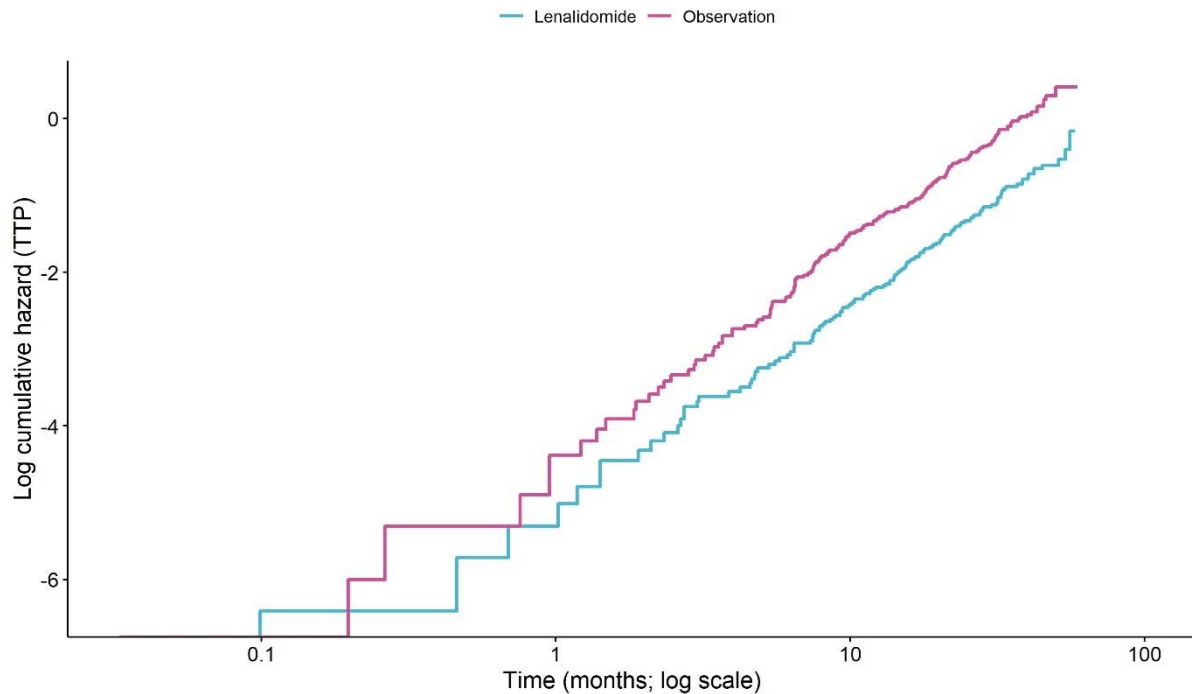
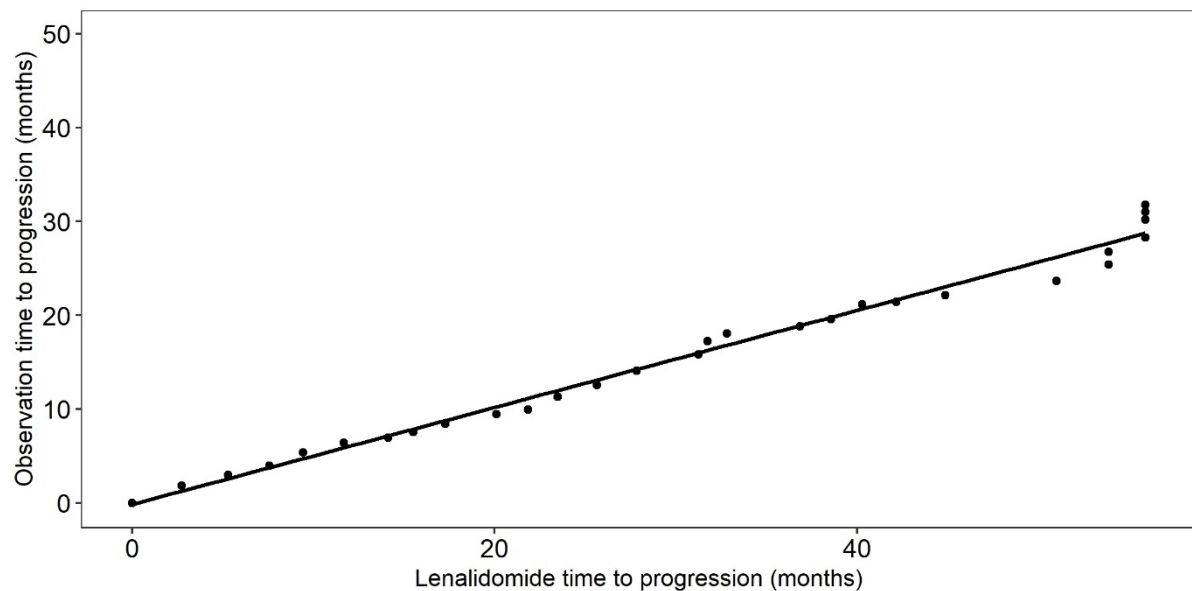

Figure 8 Quantile-quantile plot for time to progression by maintenance treatment (Myeloma XI)



The goodness of fit statistics for the parametric models fit to the Myeloma XI TTP data are displayed in Table 15. Model coefficient values are presented in Table 16.

The goodness of fit statistics indicate that the Weibull model provides the best fit to the observed within-trial data based on both AIC and BIC. The AIC values also indicate that the generalized gamma model is comparable with the fit of the Weibull model; however, given the near identical fit and the additional complexity of the generalized gamma model, the latter model appears penalized when considering the BIC. The goodness of fit statistics also indicate that the log-normal model has a poor fit to the data based upon both AIC and BIC.

Table 15 Parametric survival models for time to progression – goodness of fit statistics (Myeloma XI)

Distribution	AIC	AIC rank	BIC	BIC rank
Exponential	5390.5	5	5400.4	5
Generalised gamma	5379.3	2	5399.0	4
Gompertz	5382.0	3	5396.8	2
Log-logistic	5382.2	4	5397.1	3
Log-normal	5407.8	6	5422.6	6
Weibull	5377.3	1	5392.1	1

Key: AIC, Akaike information criterion; BIC, Bayesian information criterion; TTP, time to progression.
Notes: Cells shaded in green are within 5 points of the best fitting model.

Table 16 Time to progression parametric survival model – model coefficient values (Myeloma XI)

Coefficient	Exp	GG	Gom	LL	LN	Wei
TRT: Lenalidomide (ref: Observation)	-0.808	0.686	-0.827	0.716	0.760	0.683
Shape			0.001	0.330		0.191
Rate	-7.147		-7.368			
Scale				6.757		7.052
Meanlog					6.835	
Sdlog					0.337	
Mu		7.046				
Sigma		-0.174				
Q		0.971				

Key: Exp, exponential; GG, generalised gamma; Gom, Gompertz; LL, log-logistic; LN, log-normal; Wei, Weibull.

The parametric survival curves are presented in Figure 9; the KM curve has been overlaid to aid the assessment of visual fit. Estimates at different timepoints for each

treatment by distribution are presented in Table 17. The goodness of fit statistics are also reflected in the assessment of visual fit; for both treatments, the Weibull, generalized gamma and Gompertz models provide good visual fits to the observed data, while the log-normal, log-logistic and exponential model overestimate PFS compared to the tail of the observation KM. The generalized gamma and the Weibull models produce near identical results.¹

When considering the parametric curves beyond the end of the observed trial data, it is observed that at 20 years the log-normal, log-logistic and exponential distributions provide the most optimistic estimates for time to progression, whereas the Gompertz followed by the Weibull and generalised gamma distributions.

¹ this is likely to be because of the generalized gamma model estimating the Q parameter to be 0.97 (where the generalized gamma model reduces to a Weibull when $Q = 1$)

Figure 9 Fitted parametric survival curves for time to progression by maintenance treatment (Myeloma XI)

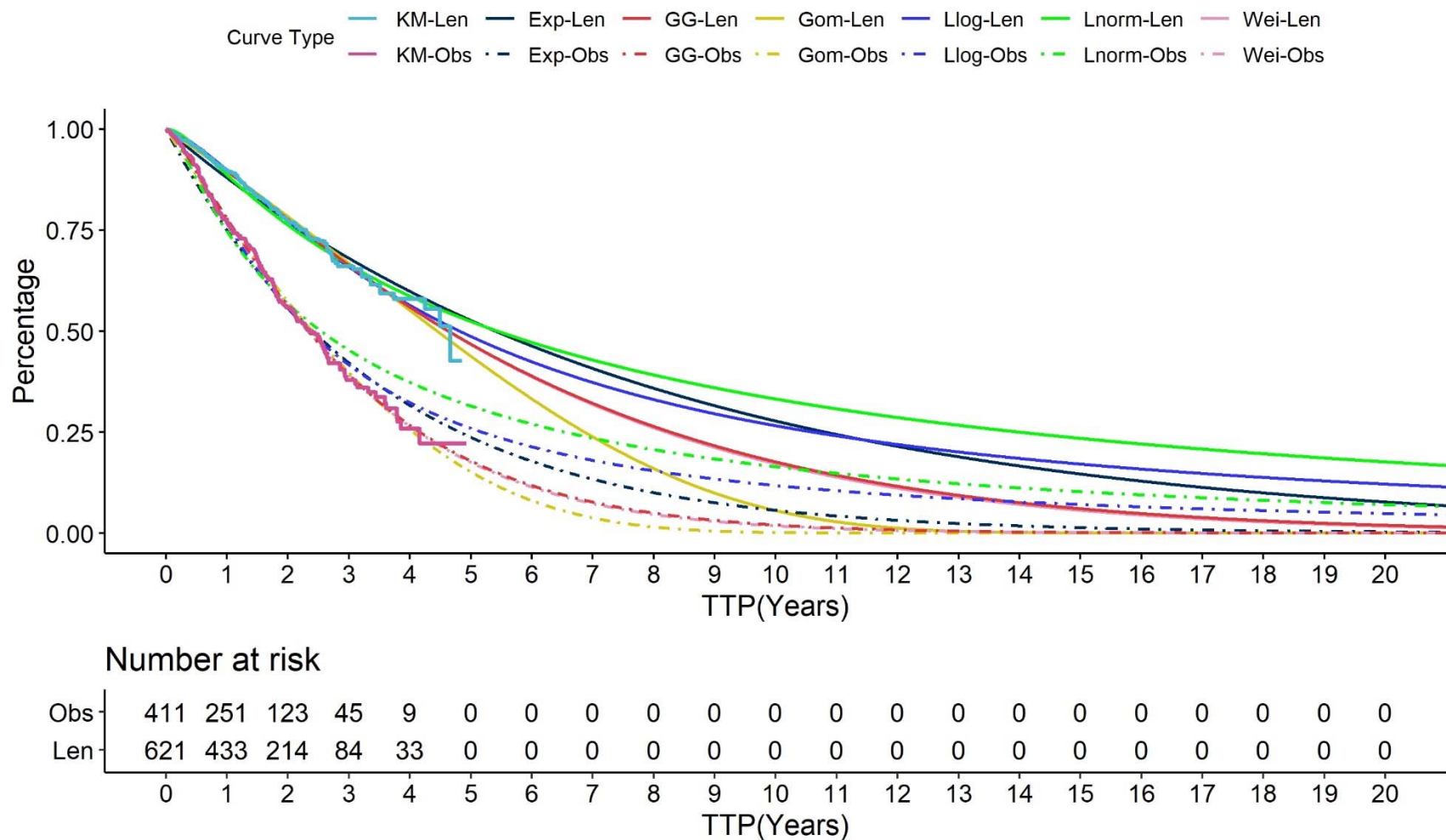

Key: Kaplan–Meier; Exp, exponential; GG, generalized gamma; Gom, Gompertz; Len, lenalidomide; Llog, log-logistic; Lnorm, log-normal; Obs, observation; PBO, placebo; PFS, progression-free survival; Wei, Weibull.

Notes: The Weibull curve is not visible on the plot as it is almost directly behind the generalized gamma curve.

Table 17 Proportion of patient's progression-free (time to progression) by survival model, time and maintenance treatment

Time (years)	Number at risk		KM		Exponential		Generalized gamma		Gompertz		Log-logistic		Log-normal		Weibull	
	Len	Obs	Len	Obs	Len	Obs	Len	Obs	Len	Obs	Len	Obs	Len	Obs	Len	Obs
0	621	411	1.000	1.000	1.000	1.000	1.000	1.000	1.000	1.000	1.000	1.000	1.000	1.000	1.000	1.000
1	433	251	0.897	0.768	0.880	0.750	0.897	0.779	0.895	0.777	0.899	0.767	0.887	0.748	0.897	0.780
2	214	123	0.772	0.559	0.774	0.563	0.778	0.562	0.784	0.573	0.773	0.557	0.763	0.568	0.778	0.563
5	-	-	-	-	0.527	0.237	0.468	0.179	0.438	0.152	0.487	0.260	0.524	0.315	0.467	0.176
10	-	-	-	-	0.278	0.056	0.176	0.020	0.056	0.001	0.266	0.118	0.332	0.164	0.172	0.018
20	-	-	-	-	0.077	0.003	0.019	0.000	0.000	0.000	0.121	0.048	0.176	0.070	0.017	0.000

Pre-progression survival

Figure 10 presents the pre-progression survival (PrePS) KM and the summary statistics respectively, for the myeloma XI study by maintenance treatment. The KM is incredibly immature and with only 10 events (1.0%) observed across both treatment arms. Given the immaturity of the data extrapolation of PrePS is not appropriate and has not been presented.

Figure 10 Kaplan–Meier of pre-progression survival by maintenance treatment (Myeloma XI)

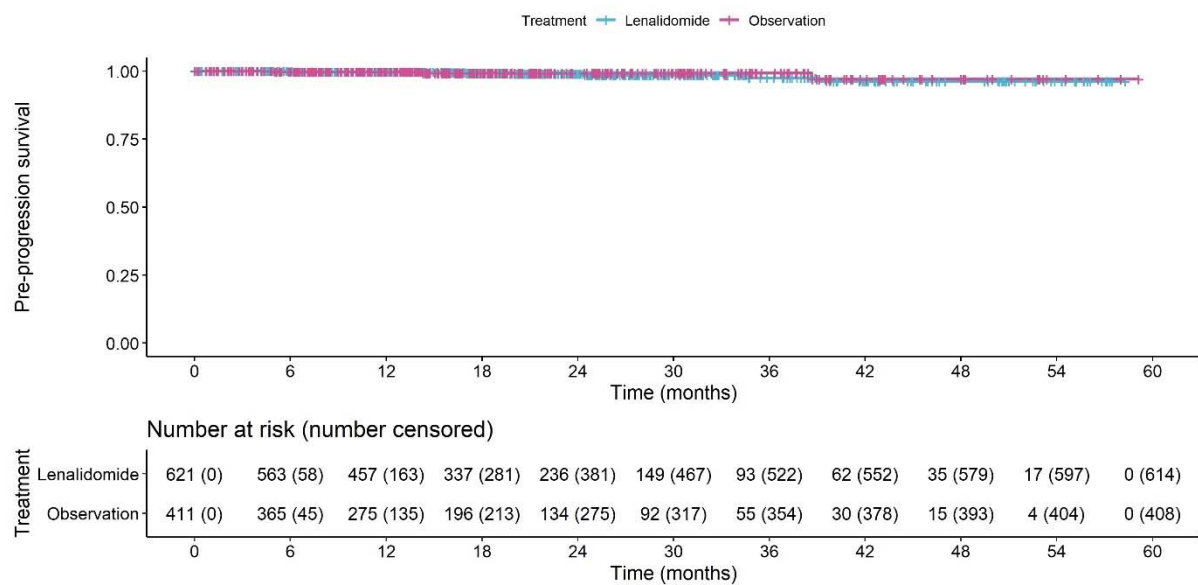

Table 18 Pre-progression survival summary statistics by maintenance treatment (Myeloma XI)

Treatment	n	Events	Censored	Median (months; 95% CI)	HR (95% CI)
Lenalidomide	621	7 (1.1%)	614 (98.9%)	NR (NR, NR)	1.37 (0.35, 5.30)
Observation	411	3 (0.7%)	408 (99.3%)	NR (NR, NR)	

Key: CI, confidence interval, HR, hazard ratio; NA, not applicable; NR, not reached.

Post-progression survival

Figure 11 and Table 19 present the post-progression survival (PostPS) KM and the summary statistics respectively, for the Myeloma XI study by maintenance treatment. The KM shows that there is little difference in post-progression survival up until 12 months, with the curves crossing each other after approximately 5 months. After 18 months, the curves begin to separate with patients in the observation arm surviving longer following progression than those in the lenalidomide arm; at this time, 70% of cases are censored and the number of deaths is very low.

Figure 11 Kaplan–Meier post-progression survival by maintenance treatment (Myeloma XI)

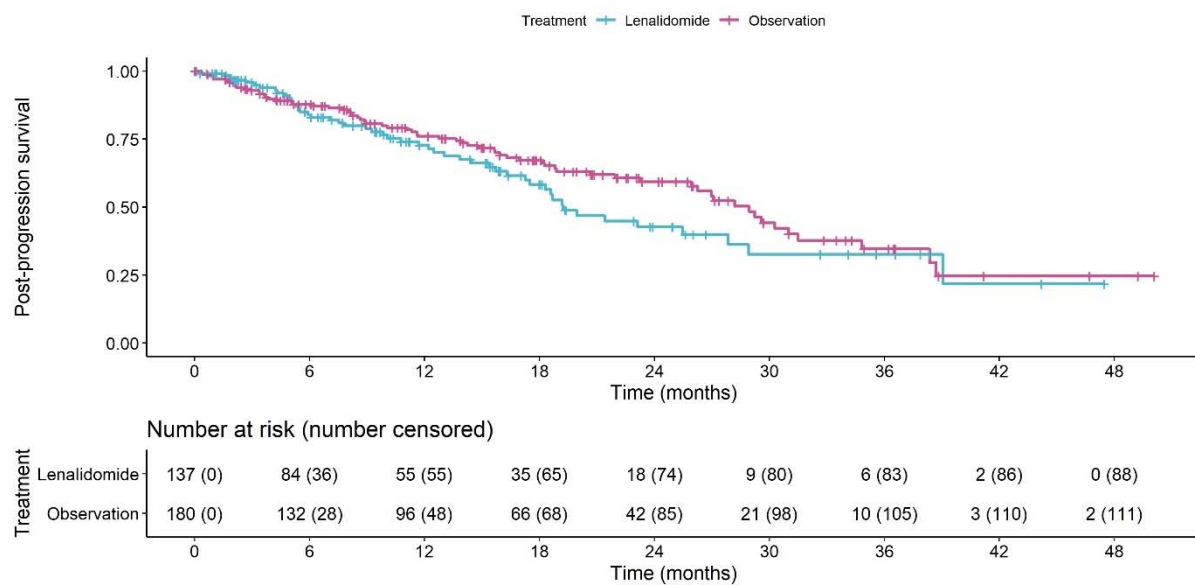

Table 19: Post-progression survival summary statistics by maintenance treatment (Myeloma XI)

Treatment	n	Events	Censored	Median (months; 95% CI)	HR (95% CI)
Lenalidomide	137	49 (35.8%)	88 (64.2%)	19.2 (17.5, 28.9)	1.28 (0.88, 1.85)
Observation	180	67 (37.2%)	113 (62.8%)	28.9 (25.9, 34.8)	

Key: CI, confidence interval, HR, hazard ratio; NA, not applicable; NR, not reached.

To determine whether it was appropriate to fit combined models (models fit with a treatment covariate), the PH and AFT assumptions were assessed. The PH assumption was not deemed appropriate based on the log-cumulative hazard plot (Figure 12) in which the curves for each treatment cross each other, and don't appear parallel throughout the follow-up period. The AFT assumption was also not

deemed appropriate as the points on the quantile-quantile plot (Figure 13) do form a straight line. As such, only separate models are presented below.

Figure 12 Log cumulative hazard plot for post-progression survival by maintenance treatment (Myeloma XI)

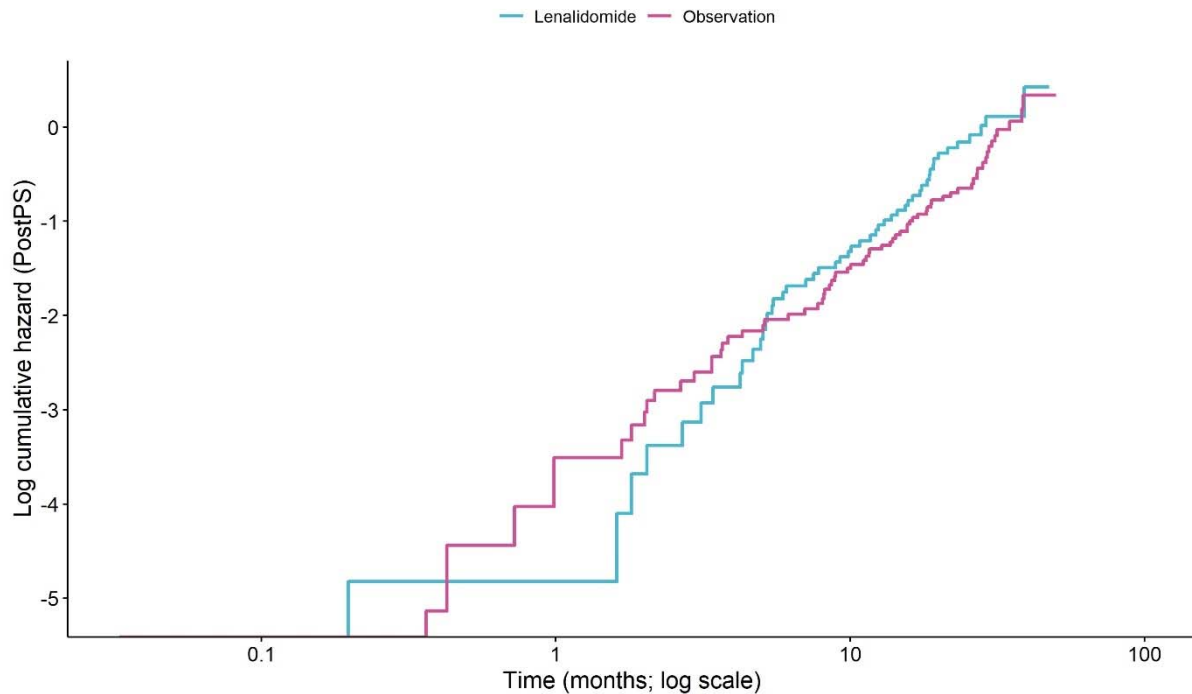
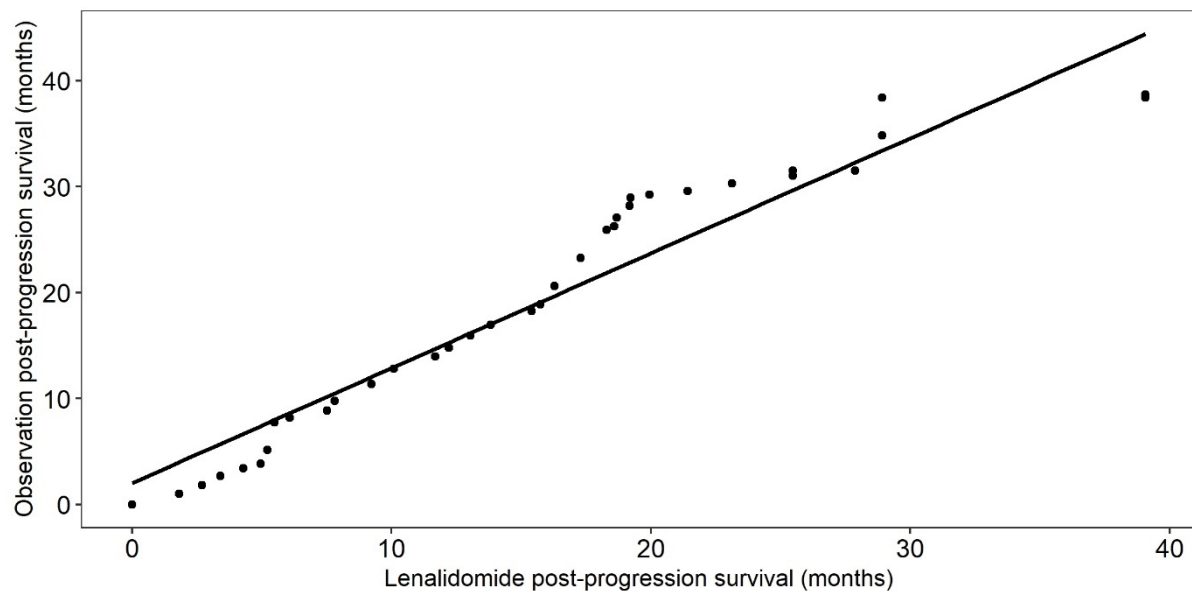

Figure 13 Quantile-quantile plot for post-progression survival by maintenance treatment (Myeloma XI)



The goodness of fit statistics for the parametric models fit to the Myeloma XI PostPS data are displayed in Table 20. Model coefficient values are presented in Table 21 for the lenalidomide arm and in Table 22 for the observation arm.

The AIC values indicate that the log-logistic distribution provides the best fit to the lenalidomide arm for PostPS with all other curves providing a similarly good fit to the data. The BIC statistic more heavily penalises more complex models, as such the BIC values indicate the 1-parameter exponential model provides the best fit to the data while the 3-parameter generalised gamma is the only model which provides a worse fit than the exponential distribution. For the observation arm, the AIC values indicate the the Gompertz model provides the best fit to the observed data, with all models other than the log-normal distribution providing similar fits to the data. The BIC values however indicate that the exponential model provides the best fit to the data with only the Gompertz and the Weibull distributions providing a similar fit to the data.

Table 20 Parametric survival models for post-progression survival – goodness of fit statistics.

Model	Lenalidomide				Observation				Total ^a			
	AIC	AIC rank	BIC	BIC rank	AIC	AIC rank	BIC	BIC rank	AIC	AIC rank	BIC	BIC rank
Exp	777.2	3	780.1	1	1090.2	2	1093.4	1	1867.4	2	1873.5	1
GG	777.3	4	786.1	6	1091.9	4	1101.5	5	1869.3	4	1887.6	5
Gom	778.2	5	784.0	4	1090.1	1	1096.5	2	1868.3	3	1880.5	3
LL	775.0	1	780.9	2	1094.7	5	1101.1	4	1869.7	5	1882.0	4
LN	778.4	6	784.2	5	1098.6	6	1105.0	6	1876.9	6	1889.2	6
Wei	776.0	2	781.8	3	1091.2	3	1097.6	3	1867.2	1	1879.4	2

Key: AIC, Akaike Information Criterion; BIC, Bayesian Information Criterion; Exp, exponential; GG, generalized gamma; Gom, Gompertz; LL, log-logistic; LN, log-normal; Wei, Weibull.
Notes: green cells indicate models within 5 points of best fitting AIC/BIC; ^a, the estimate is the sum of the AIC/BIC for both treatment arms

Table 21 Post-progression survival parametric survival model – model coefficient values – lenalidomide arm (Myeloma XI)

Coefficient	Exp	GG	Gom	LL	LN	Wei
Shape			0.000	0.410		0.212
Rate	-6.910		-7.078			
Scale				6.471		6.800
Meanlog					6.512	
Sdlog					0.220	
Mu		6.705				
Sigma		-0.055				
Q		0.656				

Key: Exp, exponential; GG, generalised gamma; Gom, Gompertz; LL, log-logistic; LN, log-normal; Wei, Weibull.

Table 22 Post-progression survival parametric survival model – model coefficient values – observation arm (Myeloma XI)

Coefficient	Exp	GG	Gom	LL	LN	Wei
Shape			0.001	0.235		0.105
Rate	-7.121		-7.347			
Scale				6.764		7.055
Meanlog					6.809	
Sdlog					0.404	
Mu		7.189				
Sigma		-0.577				
Q		1.886				
Key: Exp, exponential; GG, generalised gamma; Gom, Gompertz; LL, log-logistic; LN, log-normal; Wei, Weibull.						

The parametric survival curves are presented in Figure 14 for both treatments arms, given the closeness of the curves the curves have also been presented separately for the lenalidomide arm (Figure 15) and observation arm (Figure 16); in each case the KM curve has been overlaid to aid the assessment of visual fit. Estimates at different timepoints for each treatment by distribution are presented in Table 23. Note, although presented below the generalised gamma curve for the observation arm failed to converge.

In line with the goodness of fit statistics, all distributions provide a similar fit to the lenalidomide arm, with all distributions fitting the KM data well up until 1.5 years, then overestimates PostPS up until 3 years, though there are very few patients at risk at this time. For the observation arm, all curves give a similar fit to the data up until 2 years, after 2 years the curves disperse, with all curves other than the Weibull and Gompertz overestimating PostPS after this time, though there are few patients at risk after 3 years.

When considering the extrapolated period for lenalidomide, the log-normal and log-logistic curves provide the most optimistic estimates of PostPS, whereas the Gompertz and Weibull provide the most pessimistic long-term estimates, with almost all patients dead prior to 10 years post progression. For the observation arm, the log-normal and log logistic provide the most optimistic extrapolations with 8.2% and

6.3% of patients still being alive 20 years post progression respectively. The Gompertz and Weibull models provide the most pessimistic extrapolations with almost all patients dead after 10 years post progression.

Figure 14 Fitted parametric survival curves for post-by maintenance treatment (Myeloma XI)

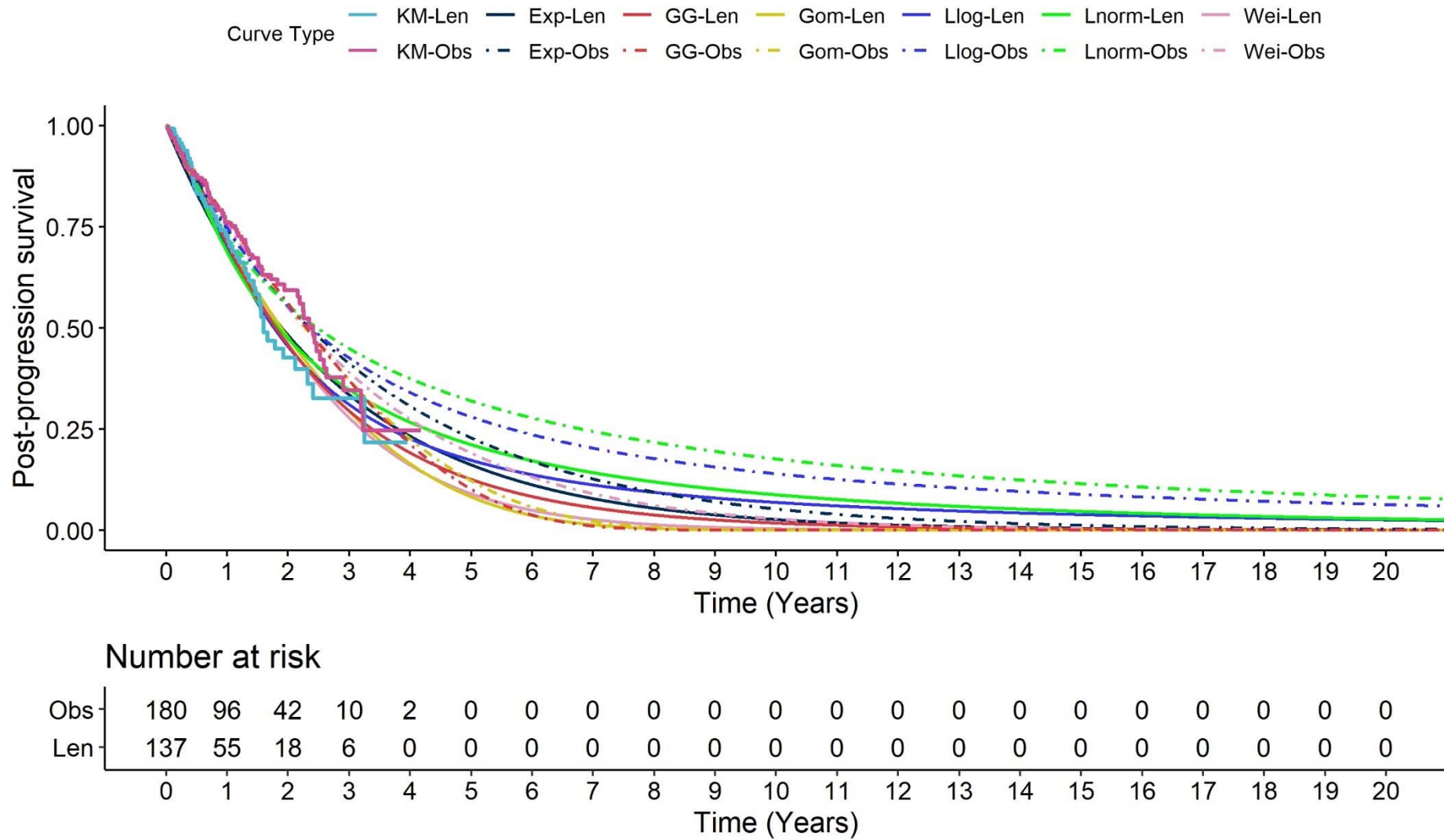

Figure 15 Fitted parametric survival curves for post-progression survival – lenalidomide arm (Myeloma XI)

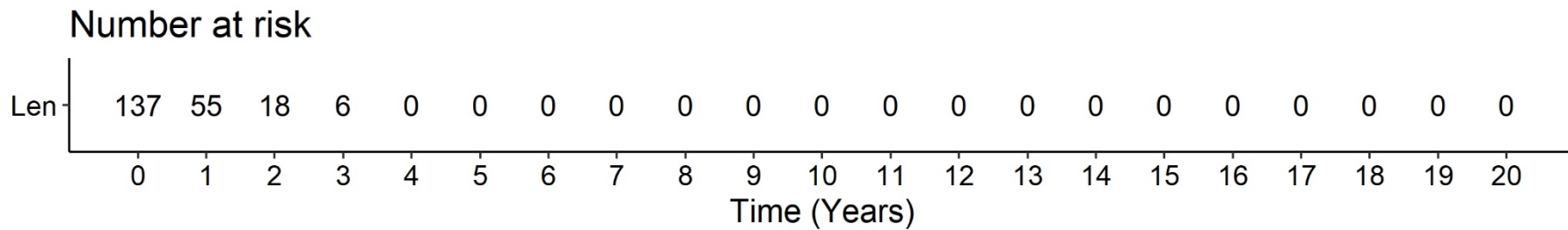
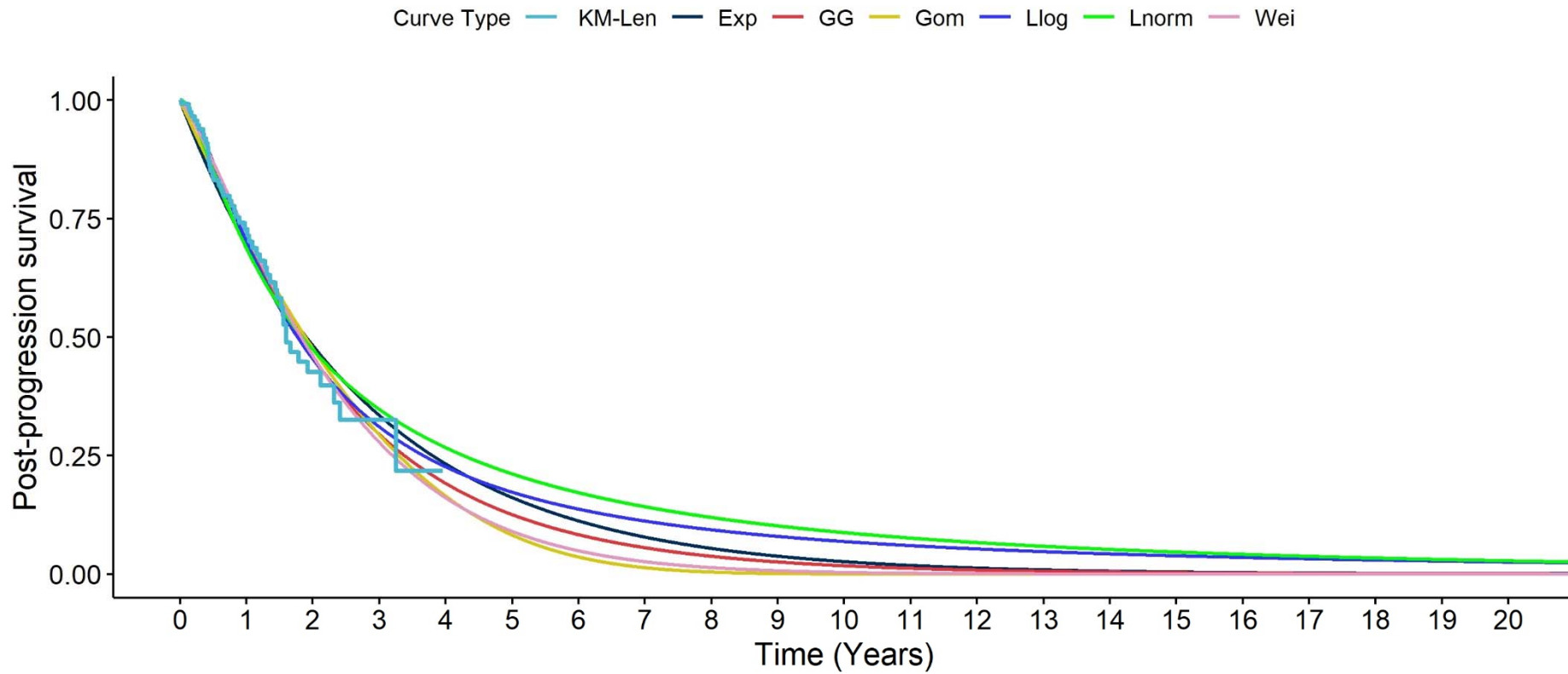

Table 23 Proportion of patient's alive post-progression by survival model, time and maintenance treatment

Time (years)	Number at risk		KM		Exponential		Generalized gamma		Gompertz		Log-logistic		Log-normal		Weibull	
	Len	Obs	Len	Obs	Len	Obs	Len	Obs	Len	Obs	Len	Obs	Len	Obs	Len	Obs
0	137	180	1.000	1.000	1.000	1.000	1.000	1.000	1.000	1.000	1.000	1.000	1.000	1.000	1.000	1.000
1	55	96	0.728	0.760	0.695	0.744	0.709	0.770	0.714	0.769	0.703	0.749	0.688	0.728	0.720	0.758
2	18	42	0.427	0.594	0.482	0.554	0.458	0.561	0.476	0.556	0.454	0.554	0.474	0.557	0.461	0.549
5	-	-	-	-	0.162	0.229	0.126	0.102	0.083	0.122	0.173	0.280	0.212	0.320	0.090	0.191
10	-	-	-	-	0.026	0.052	0.017	0.000	0.000	0.000	0.069	0.139	0.087	0.176	0.003	0.028
20	-	-	-	-	0.001	0.003	0.001	0.000	0.000	0.000	0.025	0.063	0.028	0.082	0.000	0.000

B11. In the company's model, the time-on-treatment (ToT) curve is adjusted to ensure the hazard of discontinuation cannot fall below the hazard of a PFS event. Please justify why this assumption was imposed within the model, specifically in preference to another adjustment approach (e.g. stopping the ToT curve from crossing the PFS curve).

In the base case the ToT and PFS curves do not cross. The ToT curve is constrained to not allow the implied hazard to fall below the hazard of a PFS event but only after a period of 25 years in the base case. This model option was initially included in order to avoid a possible scenario in which all patients discontinue lenalidomide and are no longer receiving the costs of treatment but continue to receive the benefits of lenalidomide indefinitely. In the base case however the effects of this assumption are negligible. The effect can be seen in Table 24.

Table 24. Time point for use of PFS hazard for ToT

Assumption	Incremental costs		Incremental QALYs		ICER	
Constrain at 5 years						
Constrain at 10 years						
Constrain at 25 years						
No constraint						

Key: ICER, incremental cost-effectiveness ratio; QALY, quality-adjusted life year.

B12. Please clarify the following with respect to ToT:

- What equation was used to calculate ToT (e.g. end date – start date + 1)?
- What were the possible reasons for discontinuation recorded in the patient-level data for Myeloma XI?
- Why is the ToT curve from CALGB 100104 notably lower than the ToT curve from Myeloma XI (Doc B, Figure 20), yet the OS and PFS curves from both studies are similar (Doc B, Figures 12 and 16)?
- In Appendix N, the potential reasons for treatment discontinuation are discussed. Please confirm that a recorded treatment end date may be

interpreted as the last date of known treatment exposure for those that are yet to discontinue treatment.

Following the data imputation for treatment start and end times (described in response to question A17), the formula used was end time – start time + 1 day.

The possible reasons for discontinuation were the following in the patient level data:

- Clinical decision
- Disease progression or death
- Non-compliance
- Other
- Participant choice
- Secondary malignancy
- Unacceptable toxicity

Table 25 and Table 26 present the reasons for treatment discontinuation as reported in the patient level data and after data imputation respectively.

Table 25 Reasons for discontinuation as reported in the patient level data

Reason for discontinuation	No. of patients
Clinical decision	12
Disease progression	94
Death	5
Non-compliance	1
Other	14
Participant choice	16
Secondary malignancy	2
Unacceptable toxicity	54
Not reported	384

Table 26 Reasons for discontinuation after data imputation

Reason for discontinuation	No. of patients
Clinical decision	12
Disease progression or death	101
Death	5
Non-compliance	1
Other	14

Participant choice	16
Secondary malignancy	2
Unacceptable toxicity	54
Not reported (assumed to be still on treatment)	377

We used the opinion of a clinical expert to assess the reasons for this similarity. The expert concluded that because data from Myeloma XI matches the data from the meta-analysis almost perfectly, with a similar safety profiles, it is possible to argue that both schedules are highly effective with a reasonable safety profile

The last known date on treatment has been interpreted equal to assuming that patients are still on treatment at that date. In the time on treatment analysis, these patients are censored.

B13. Please provide parametric survival models fitted to the data from CALGB 100104 for the outcomes of OS, PFS, ToT, and (if available) PFS2. Where appropriate, please use the crossover-adjusted outcomes data provided in the company submission to inform the parametric survival curves. Please also incorporate functionality within the submitted economic model to explore the use of these curves.

Kaplan-Meier estimators and parametric extrapolations for CALGB 1001104 are provided in Figure 17, Figure 18, Figure 19, Figure 20, Figure 21 for all model outcomes.

Figure 17 Fit of the extrapolated survival curves to the Kaplan Meier data for OS with adjustment for crossover using RPSFT without adjustment for covariates for CALGB dataset (LEN, stratified)

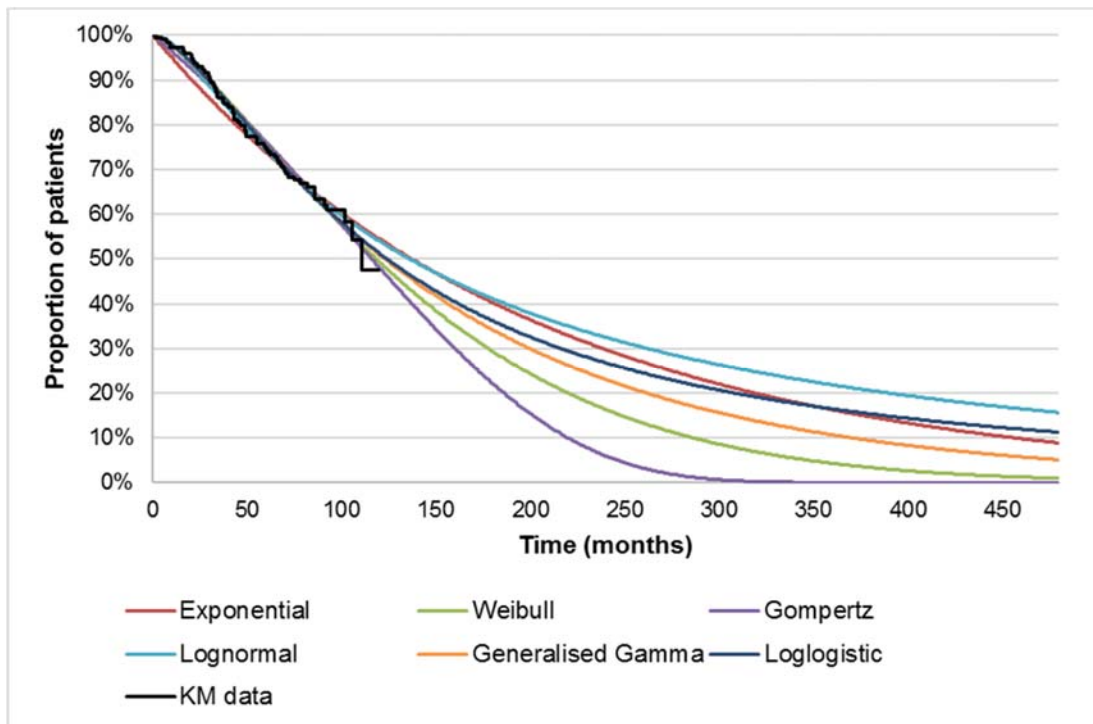

Figure 18 Fit of the extrapolated survival curves to the Kaplan Meier data for OS with adjustment for crossover using RPSFT without adjustment for covariates for CALGB dataset (no treatment, stratified)

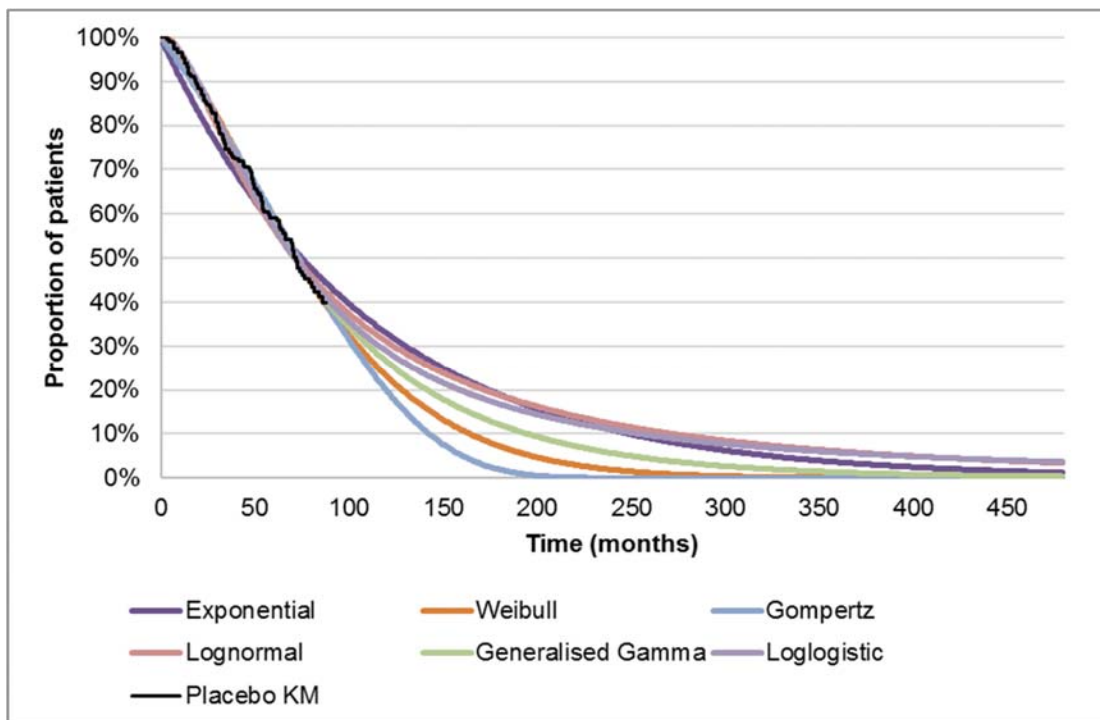

Figure 19 Fit of the extrapolated survival curves to the Kaplan Meier data for PFS with adjustment for crossover using RPSFT without adjustment for covariates for CALGB dataset (LEN, stratified)

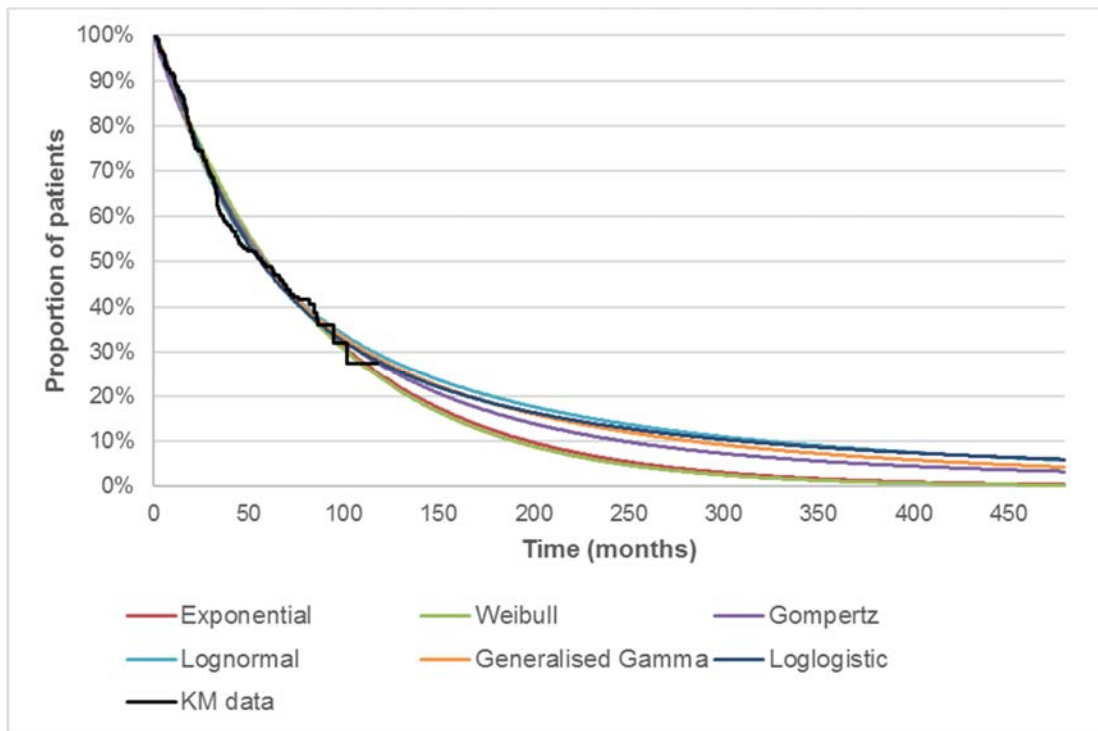

Figure 20 Fit of the extrapolated survival curves to the Kaplan Meier data for PFS with adjustment for crossover using RPSFT without adjustment for covariates for CALGB dataset (no treatment, stratified)

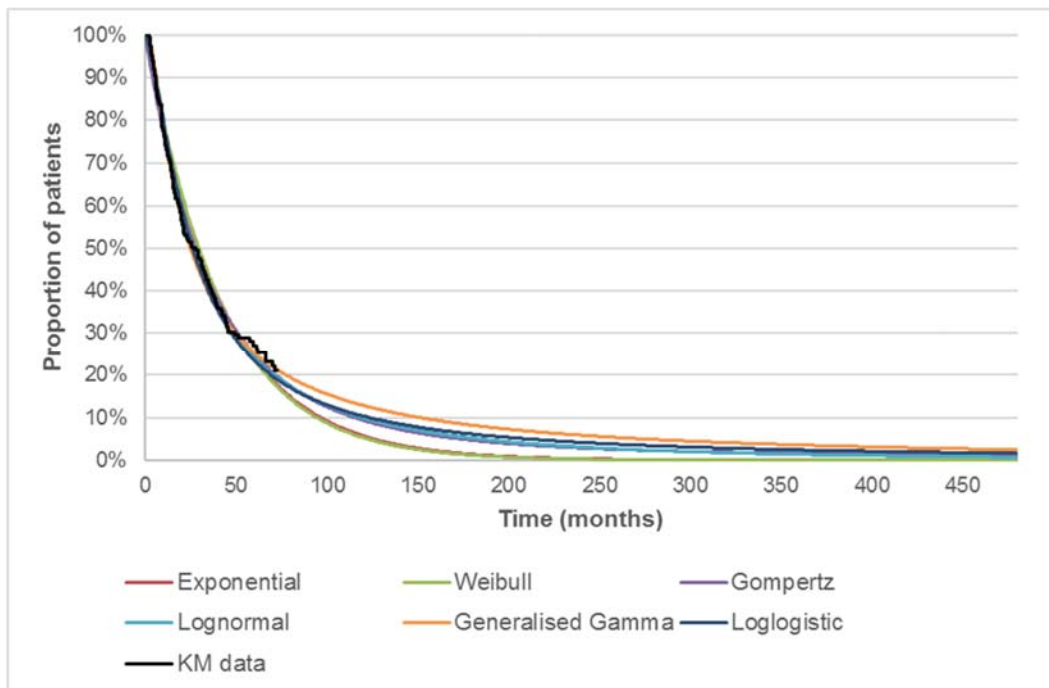
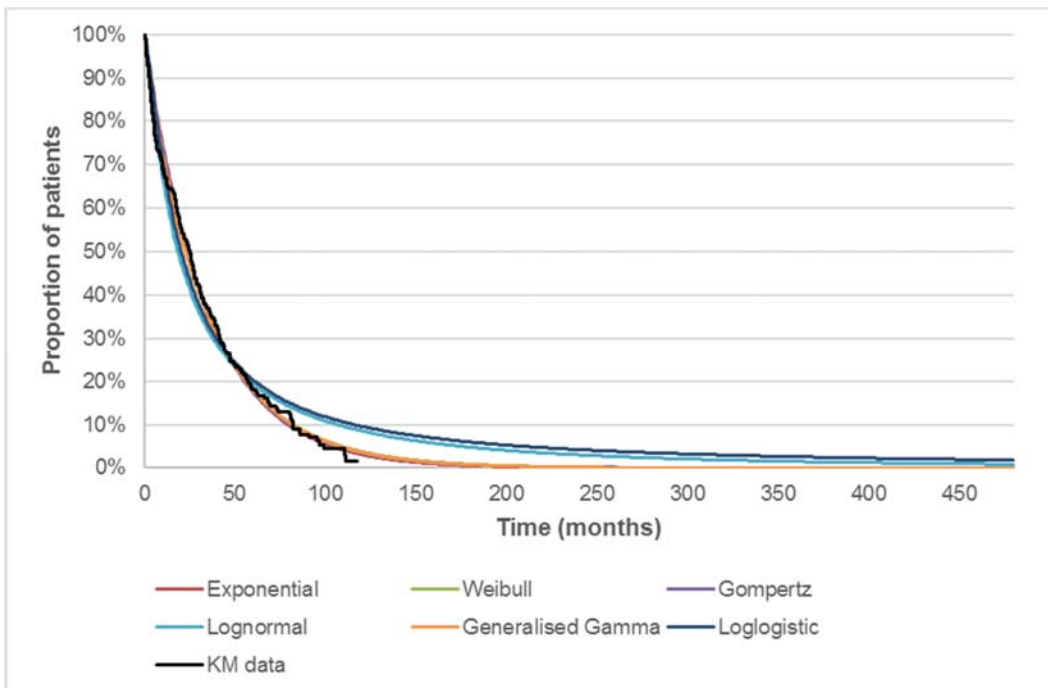
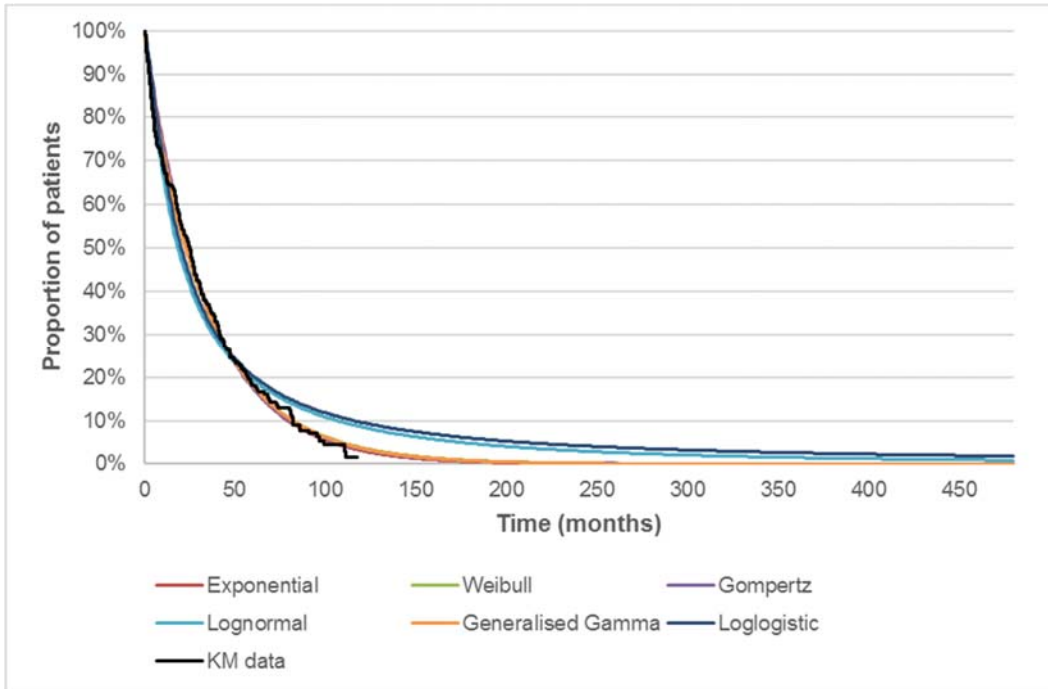

Figure 21 Fit of the extrapolated survival curves to the Kaplan Meier data for TOT without adjustment for crossover without adjustment for covariates for CALGB dataset (LEN)



Parametric survival models for OS, PFS, and ToT from CALGB 100104 (adjusted for cross-over using rank preserving structure failure time models (RPSFTM), where required, have been included as an option in the revised electronic model (see B1). The effect on the base case can be seen in Table 27.

Table 27 Alternative parametric survival models

Assumption	Incremental costs	Incremental QALYs	ICER
Myeloma XI (basecase)			
CALGB			

Medical resource use

B14. The company model includes a sensitivity analysis for medical resource use based on a “Revlimid study”. In this scenario, the cost incurred per cycle is approximately double in the progressed state versus the progression-free state. However, in the company base-case analysis (which uses data from NICE TA587), the cost per cycle falls from approximately £254 to £231 upon progression. Please clarify which of these scenarios is expected to represent a better reflection of the true medical resource use costs, acknowledging that TA587 was based on a previously untreated MM population.

The “Revlimid study” referred to is based on a chart review of 61 UK patients. Only two of these patients received lenalidomide maintenance therapy post-SCT. As such, estimates used in the economic evaluation for this scenario are based on resource use observed in patients who did not receive an SCT. There is some uncertainty regarding the medical resource use in this population, however we believe both sources provide reasonable estimates. Furthermore, and the difference between sources in terms of cost-effectiveness is negligible. The estimates used in TA587 were preferred for use in the base-case on the basis that these had been subject to critical review during TA587 and for consistency between appraisals.

Health-related quality of life

B15. In the company's base-case analysis, utility values from a study by Acaster *et al.* (2013) were used, and a sensitivity analysis using different utility values from a study by Hatswell *et al.* (2019) was also considered. Please provide the rationale for selecting the former of these studies in preference to the latter.

The study by Hatswell *et al.*, 2019² was a meta-analysis of utility values from a range of studies conducted in patients with MM. Whilst the meta-analysis generated utility values for first, second, third and fourth-line treatments, the values were a synthesis of utilities across a non-homogeneous patient population, both eligible and non-eligible for ASCT. Specifically, only five studies included in the analysis reported the proportion of patients who received stem cell transplant (including Acaster *et al.*³).

Given that the eligibility criteria for ASCT are an important prognostic factor for treatment outcomes, it was considered that the meta-analysis generated values that would not be in alignment with the scope of this submission. An alternative approach was taken, screening the Hatswell *et al.* (2019) meta-analysis bibliography to identify studies satisfying the relevance criteria for the decision problem in this submission.²

Following the review of these, and other studies identified by the SLR (Appendix H), the base-case analysis uses data presented by Acaster *et al.*³ The authors collected EQ-5D-3L in UK patients at different stages of the disease, allowing population of the model health states with data consistent with the reference case; 70% of the 'treatment free interval' group reported stem cell transplant as their last treatment. Data from Hatswell *et al.* (2019) was used as a scenario analysis.

Economic model file

B16. In the company's model, a "reset to base-case" button is included, but when used yields a set of results that does not match the company's base-case results in the model (incremental costs of [REDACTED] versus [REDACTED], and incremental QALYs of [REDACTED] versus [REDACTED]). This appears to be due to a minor error in the macro which refers to the final row in the "Control" sheet and causes it to replace starting age of 66

with 0. Please confirm if this understanding is correct. If so, please correct it in the model.

We have amended the reset function and corrected the error.

B17. For the avoidance of doubt, please confirm that all references to a gamma distribution (with respect to survival analysis) are related to a generalised gamma model

We confirm that all references to Gamma are to a generalised gamma model.

Section C: Textual clarification and additional points

C1. In Doc B, Table 7, it is stated that the Myeloma XI cohort relevant to the decision problem includes patients who “achieved a maximum response to induction therapy (with or without intensification therapy)”. Given the Jackson et al trial publication states that this cohort is those who “achieved at least a minimal response”, should Table 7 say “minimal response”?

Yes, this is correct. Table 7 should read:

Table 7 Myeloma XI: cohort relevant to decision problem

This cohort includes patients who:

- entered the intensive pathway
- completed randomized induction (with or without intensification therapy as per the protocol)^a
- achieved a **minimum** response^b to induction therapy (with or without intensification therapy)^a
- were subsequently randomized to maintenance with lenalidomide 10 mg or observation under protocol Version 5.0 onwards (14 September 2011).

This analysis differs from the overall published maintenance analysis as it excludes the following patients:

1. Patients in the non-intensive treatment pathway (ineligible for ASCT).
2. Patients randomized to maintenance with lenalidomide 25 mg or observation before protocol Version 5.0.
3. Patients randomized to maintenance with lenalidomide and vorinostat (discontinued with protocol Version 6.0 (28 June 2013)).

Likewise, Table 8 should also be corrected,

Table 8. Key eligibility criteria for maintenance therapy in Myeloma XI

Inclusion criteria	Exclusion criteria
<p>Patients aged ≥ 18 years with newly diagnosed symptomatic MM or non-secretory MM based on:</p> <ul style="list-style-type: none"> • bone marrow clonal plasma cells; • organ or tissue impairment and/or symptoms considered by a clinician to be myeloma-related; • presence of paraprotein (M-protein) in serum or urine. 	<p>Previous or concurrent malignancies, including:</p> <ul style="list-style-type: none"> • myelodysplastic syndromes; • \geq grade 2 peripheral neuropathy; • acute renal failure (unresponsive to up to 72 h of rehydration based on creatinine $> 500 \mu\text{mol/L}$ or urine output $< 400 \text{ mL}$ per day, or requiring dialysis); • lactation or breast feeding • active or previous hepatitis C.
Additional criteria for maintenance randomisation	
<ul style="list-style-type: none"> • Patients with minimum response to a minimum of 4 cycles of randomized induction therapy with CTD, RCD or KCRD with or without up to 8 cycles of VCD. 	<ul style="list-style-type: none"> • Progressive disease or no change following lenalidomide induction therapy (component of KCRD) • Failed response to all protocol treatment (i.e. no response to any treatment following enrolment into Myeloma XI) • Receipt of any anti-myeloma treatment other than randomized trial treatment • Progressive disease or relapse from complete response.

Section C: Textual clarification and additional points

C2. [REDACTED]
 [REDACTED]
 [REDACTED]

Celgene (a BMS company) do not believe this is an appropriate request. The PAS has been approved by NHS England [REDACTED]

[REDACTED]
 [REDACTED]
 [REDACTED]

[REDACTED]

[REDACTED]

[REDACTED]

[REDACTED]	[REDACTED]	[REDACTED]
[REDACTED]	[REDACTED]	[REDACTED]
[REDACTED]	[REDACTED]	[REDACTED]
[REDACTED]	[REDACTED]	[REDACTED]

[REDACTED]

[REDACTED]

Appendix 1. Screening of bibliography, McCarthy et al (2017)

Study	Population	Randomisation	Intervention	Comparator	Reason for exclusion
CTN 0702 (RV-MM-BMTCTN-0494) NCT01109004 Stadtmauer et al. 2019	MM, USA	Randomised post ASCT consolidation: 1. 1 ASCT then RVD consolidation then LEN maintenance 2. 2 nd ASCT then LEN maintenance 3. 1 ASCT then LEN maintenance	LEN 10 to 15 mg daily maintenance		All participants received LEN maintenance
DSMM-XIII (RV-MM-DSMM-0349)	MM, Germany	1. ASCT then LEN 2. No ASCT, LEN + DEX	LEN 10 mg daily maintenance	LEN + DEX 25 mg days 1-21/28	Study ongoing, no results yet; LEN+DEX comparator arm have not had ASCT
DSMM-XIV (RV-MM-DSMM-0555)	MM, Germany	1. Autologous SCT + LEN maintenance 2. 2x Autologous SCT + LEN maintenance 3. Allogenic SCT + LEN maintenance 4. 2 x autologous SCT, no maintenance	1 or 2 x ASCT + LEN 10 mg/day maintenance	2 x ASCT no maintenance	Only comparison for LEN maintenance vs no maintenance is after 2 x ASCT. Seems to be ongoing with no results available
FORTE (RV-CL-MM-PI-002903) Gay et al. 2017, Gay et al. 2018	MM, Italy	First randomisation: 1. 4 cycles KRd induction then ASCT then KRd consolidation 2. 12 cycles KRd with no ASCT 3. KCd induction then ASCT then KCd consolidation Second randomisation: 1. LEN 2. LEN + carfilzomib	LEN 10 mg/day days 1-21/28 maintenance	LEN 10 mg/day days 1-21/28 + carfilzomib 36 mg/m ² days 1, 2, 15, 16 maintenance	Conference abstracts (Gay 2017, Gay 2018). All patients had either ASCT + consolidation or no ASCT. Maintenance study ongoing, no results reported for LEN maintenance vs LEN-Carfilzomib
GEM 2014 (RV-MM-PI-0800)	MM, Spain	1. LEN + DEX 2. LEN + DEX + ixazomib	LEN 15 mg/day days 1-21/28 + DEX 20 mg days 1-4, 9-12 maintenance	LEN 15 mg/day days 1-21/28 + DEX 20 mg days 1-4, 9-12 + ixazomib 4 mg/day days 1, 8, 15 maintenance	Not lenalidomide monotherapy
GMMG-MM5 (RV-MM-GMMG-423) EudraCT 2010-019173-16	MM, Germany	A1. 3 cycles PAd (bortezomib+ doxorubicin + dexamethasone) induction Then 2 cycles LEN consolidation	LEN 10 mg/day maintenance	LEN 10 mg/day maintenance	Not in people receiving ASCT; all received LEN consolidation; no maintenance until progression .

http://www.isrctn.com/ISRCTN05622749		Then LEN 10mg/day on days 1-21 for 2 years B1. 3 cycles PAd (bortezomib+ doxorubicin + dexamethasone) induction Then 2 cycles LEN consolidation Then LEN 10mg/day on days 1-21 until CR is reached A2. 3 cycles VCD (bortezomib + cyclophosphamide + dexamethasone) induction Then 2 cycles LEN consolidation Then LEN 10mg/day on days 1-21 for 2 years B2. 3 cycles VCD (bortezomib + cyclophosphamide + dexamethasone) induction Then 2 cycles LEN consolidation Then LEN 10mg/day on days 1-21 until CR is reached			
HOVON 95 (RV-MM-COOP-0556) NCT01208766	MM, Netherlands	1. VMP consolidation starting 4-6 weeks after stem cell collection 2. HDM consolidation starting 4-6 weeks after stem cell collection 3. LEN maintenance, no ASCT or consolidation 4. VRD consolidation, no ASCT	LEN 10 mg/day days 1-21/28 maintenance	No comparator	Study ongoing, no results yet; Len maintenance not after ASCT; uses consolidation
IFM/DFCI 2009 (RV-MM-IFM-0444-US) (Attal 2017)	MM, USA	1. ASCT with LEN-Bortezomib 5 cycles then LEN maintenance 2. ASCT with LEN-Bortezomib 8 cycles then LEN maintenance	LEN 10 to 15 mg/day maintenance	No comparator	All participants received LEN maintenance
IFM/DFCI 2009 (RV-MM-IFM-0444-EU) (Attal 2017)	MM, Europe	1. ASCT with LEN-Bortezomib 5 cycles then LEN maintenance 2. ASCT with LEN-Bortezomib 8 cycles then LEN maintenance	LEN 10 to 15 mg/day maintenance	No comparator	All participants received consolidation
RV-MM-PI-0280	MM, Germany	1. LEN high dose 2. LEN low dose	LEN 25 g/day days 1-21 maintenance	LEN 5mg/day days 1-21/28 maintenance	No LEN 10mg/day
RV-MM-PI-0287	MM, USA	1. ASCT x 1-2 then LEN + DEX maintenance 2. Continue LEN + DEX	ASCT then LEN 25 mg/day days 1-21/28 + DEX 40	Delayed ASCT, continuing LEN 25	No LEN monotherapy arm

			mg/week maintenance	mg/day days 1-21/28 + DEX 40 mg/week maintenance	
RV-MM-PI 0385 NCT01731886 Lentzsch et al. 2015	MM, USA	1. 4 cycles LEN-Dex induction then ASCT + melphalan conditioning then LEN maintenance 2. 4 cycles LEN-Dex induction then unclear whether had ASCT but had 4 consolidation LEN-dex cycles then LEN maintenance	ASCT then LEN 10-15 mg/day days 1-21/28 maintenance after 90 to 110 days	Possible ASCT then LEN 10-15 mg/day days 1-21/28 maintenance immediately	All participants received LEN maintenance, all received consolidation or conditioning

Appendix 2. Citations of Excluded Publications, By Reason (Cost-effectiveness Review)

	Citation	Exclusion Reason
1	Ailawadhi et al. Trends in multiple myeloma presentation, management, cost of care, and outcomes in the medicare population: A comprehensive look at racial disparities. 2018. Cancer. doi: http://dx.doi.org/10.1002/cncr.31237	Intervention
2	Alfieri et al. Home care management for hematological patients: Results of a survey conducted on a regional scale by the r.E.D.E.R. Network. 2014. Haematologica. doi: --	Intervention
3	Binder et al. Drug resource use and costs for novel agents in multiple myeloma. 2012. Journal of Clinical Oncology. Conference. doi: --	Intervention
4	Burnette et al. Treatment trade-offs in myeloma: A survey of consecutive patients about contemporary maintenance strategies. 2013. Cancer	Intervention
5	Camilleri et al. The cost of myeloma: A gap analysis in the diagnostic work-up of multiple myeloma at gloucestershire hospitals nhs foundation trust. 2016. British Journal of Haematology. doi: http://dx.doi.org/10.1111/bjh.14019	Intervention
6	Chiba et al. Cost analysis of the end of life care in hematological malignancy patients. 2016. Haematologica. doi: --	Intervention
7	Cook. Economic and clinical impact of multiple myeloma to managed care. 2008. Journal of Managed Care Pharmacy. doi: --	Intervention
8	Corso et al. Direct healthcare costs of treated multiple myeloma: Results from a population-based study. 2014. Blood. Conference: 56th Annual Meeting of the American Society of Hematology, ASH. doi: --	Intervention
9	Corso et al. The impact of new technologies on multiple myeloma management: A cost-effectiveness analysis. 2012. Haematologica. doi: --	Intervention
10	Da Costa Byfield et al. Real-world treatment patterns, healthcare resource utilization (hru), and costs of initial line of therapy (lot1) in multiple myeloma (mm). 2015. Journal of Clinical Oncology. Conference. doi: --	Intervention
11	Despiegel et al. Quality of life of patients treated for multiple myeloma (mm) in france in a real-world setting. 2016. Value in health	Intervention
12	Dorothy et al. Healthcare costs among newly diagnosed multiple myeloma (mm) patients undergoing frontline stem cell transplantation in the u.S. Comparison of outpatient versus inpatientbased care. 2016. Haematologica. doi: --	Intervention
13	El-Jawahri et al. Effect of inpatient palliative care on quality of life 2weeks after hematopoietic stem cell transplantation: A randomized clinical trial. 2016. JAMA - journal of the american medical association	Intervention

1 4	Fonseca et al. Trends in overall survival and costs of multiple myeloma, 2000-2014. 2017. <i>Leukemia</i> . doi: http://dx.doi.org/10.1038/leu.2016.380	Intervention
1 5	Hari et al. Healthcare resource utilization with ixazomib or placebo plus lenalidomide-dexamethasone in the randomized, double-blind, phase 3 tourmaline-mm1 study in relapsed/refractory multiple myeloma (rrmm). 2017. <i>Haematologica</i>	Intervention
1 6	Harrison et al. The cost-effectiveness of combination therapy: Challenges of the present, solutions for the future? A myeloma analysis. 2016. <i>Annals of Oncology</i> . Conference: 41st European Society for Medical Oncology Congress, ESMO. doi: http://dx.doi.org/10.1093/annonc/mdw377.5	Intervention
1 7	Huntington et al. Assessing financial toxicity in insured patients with multiple myeloma. 2015. <i>Journal of Clinical Oncology</i> . Conference. doi: --	Intervention
1 8	Koleva et al. Healthcare costs of multiple myeloma: An italian study. 2011. <i>European Journal of Cancer Care</i> . doi: http://dx.doi.org/10.1111/j.1365-2354.2009.01153.x	Intervention
1 9	LeBlanc et al. A canadian cost analysis comparing the use of bortezomib or lenalidomide as maintenance therapies in multiple myeloma patients eligible for autologous stem cell transplant. 2014. <i>Value in Health</i> . doi: http://dx.doi.org/10.1016/j.jval.2014.03.449	Intervention
2 0	Leblanc et al. Canadian cost analysis comparing maintenance therapy with bortezomib versus lenalidomide for patients with multiple myeloma post autologous stem cell transplant. 2016. <i>Journal of Population Therapeutics and Clinical Pharmacology</i> . doi: --	Intervention
2 1	Lee et al. A retrospective study of direct cost to patients associated with the use of oral oncology medications for the treatment of multiple myeloma. 2016. <i>Journal of Medical Economics</i> . doi: http://dx.doi.org/10.3111/13696998.2015.1130710	Intervention
2 2	Leleu et al. Patient-reported health-related quality of life from the phase iii tourmaline-mm1 study of ixazomib-lenalidomide-dexamethasone versus placebo-lenalidomide-dexamethasone in relapsed/refractory multiple myeloma. 2018. <i>American journal of hematology</i>	Intervention
2 3	Messori et al. The role of bortezomib, thalidomide and lenalidomide in the management of multiple myeloma: An overview of clinical and economic information. 2011. <i>Pharmacoeconomics</i> . doi: http://dx.doi.org/10.2165/11585930-000000000-00000	Intervention
2 4	No Author. A family-centered intervention for the transition to living with multiple myeloma as a chronic illness: A pilot study. 2017. <i>Applied nursing research</i>	Intervention
2 5	Olszewski et al. Subsidies for oral chemotherapy and use of immunomodulatory drugs among medicare beneficiaries with myeloma. 2017. <i>Journal of Clinical Oncology</i> . doi: http://dx.doi.org/10.1200/JCO.2017.72.2447	Intervention
2 6 -	Parada-Saavedra et al. An update of real-world cost-utility evaluation of multiple myeloma treatments in stem cells transplant patients. 2016. <i>Value in Health</i> . doi: -	Intervention

2 7	Petrucci et al. Cost of illness in patients with multiple myeloma in italy: The comim study. 2013. Tumori. doi: http://dx.doi.org/10.1700/1361.15125	Intervention
2 8	Petrucci et al. Costs and quality of life of multiple myeloma (mm) in italy: The co.Mi.M. Study. 2009. Value in Health. doi: --	Intervention
2 9	Qerimi et al. Cost-effectiveness analysis of treating transplant-eligible multiple myeloma patients in macedonia. 2018. Clinicoeconomics and outcomes research	Intervention
3 0	Ramsenthaler et al. General symptom level, pain and anxiety predict declining health-related quality of life in multiple myeloma: A prospective, multi-centre longitudinal study. 2016. Palliative medicine	Intervention
3 1	Robinson et al. The influence of baseline characteristics and disease stage on health-related quality of life in multiple myeloma: Findings from six randomized controlled trials. 2016. British journal of haematology	Intervention
3 2	Shih et al. Rising prices of targeted oral anticancer medications and associated financial burden on medicare beneficiaries. 2017. Journal of Clinical Oncology. doi: http://dx.doi.org/10.1200/JCO.2017.72.3742	Intervention
3 3	Siskou et al. Evaluating the economic impact of novel agents for treating multiple myeloma. 2018. Value in Health. doi: http://dx.doi.org/10.1016/j.jval.2018.09.196	Intervention
3 4	Teitelbaum et al. Health care costs and resource utilization, including patient burden, associated with novel-agent-based treatment versus other therapies for multiple myeloma: Findings using real-world claims data. 2013. Oncologist. doi: http://dx.doi.org/10.1634/theoncologist.2012-0113	Intervention
3 5	Truong et al. The impact of pricing strategy on the costs of oral anti-cancer drugs. 2019. Cancer Medicine. doi: http://dx.doi.org/10.1002/cam4.2269	Intervention
3 6	Wisloff et al. Therapeutic options in the treatment of multiple myeloma: Pharmacoeconomic and quality-of-life considerations. 1999. Pharmacoeconomics	Intervention
3 7	Zober et al. Prospective functional geriatric assessment (cf-ga) in multiple myeloma (mm) patients (pts): Changes from baseline (t0) to follow up assessment (t1). 2016. Haematologica. Conference: 21st congress of the european hematology association. Denmark.	Intervention
3 8	Ashcroft et al. Chart review across eu5 in mm post-asct patients. 2018. International Journal of Hematologic Oncology. doi: http://dx.doi.org/10.2217/ijh-2018-0004	Outcomes
3 9	Ashcroft et al. Chart review across eu5 in mm post-asct patients. 2018. International Journal of Hematologic Oncology. doi: http://dx.doi.org/10.2217/ijh-2018-0004	Outcomes
4 0	Attal et al. Lenalidomide maintenance after stem-cell transplantation for multiple myeloma. 2012. New England journal of medicine	Outcomes
4 1	Baloghova and Fuksa. Pharmacotherapy costs of multiple myeloma in the czech republic: A retrospective analysis. 2013. Value in Health. doi: http://dx.doi.org/10.1016/j.jval.2013.08.384	Outcomes

4 2	Berenson et al. Elotuzumab administered over approximately 60 minutes in combination with lenalidomide and dexamethasone in patients with multiple myeloma: A phase 2 safety study. 2016. Journal of Oncology Pharmacy Practice. doi: http://dx.doi.org/10.1177/1078155215624650	Outcomes
4 3	Brown et al. Lenalidomide for multiple myeloma: Cost-effectiveness in patients with one prior therapy in england and wales. 2013. European Journal of Health Economics	Outcomes
4 4	Dimopoulos et al. Lenalidomide plus dexamethasone for relapsed or refractory multiple myeloma. 2007. New England journal of medicine	Outcomes
4 5	Goldschmidt et al. Response-adapted lenalidomide maintenance in newly diagnosed, transplant-eligible multiple myeloma: Results from the multicenter phase iii gmmg-mm5 trial. 2017. Blood	Outcomes
4 6	Holstein et al. Updated analysis of calgb (alliance) 100104 assessing lenalidomide versus placebo maintenance after single autologous stem-cell transplantation for multiple myeloma: A randomised, double-blind, phase 3 trial. 2017. The lancet	Outcomes
4 7	Holstein et al. Updated analysis of calgb (alliance) 100104 assessing lenalidomide versus placebo maintenance after single autologous stem-cell transplantation for multiple myeloma: A randomised, double-blind, phase 3 trial. 2017. The Lancet Haematology. doi: http://dx.doi.org/10.1016/S2352-3026%2817%2930140-0	Outcomes
4 8	Holstein et al. Updated analysis of calgb/ecog/bmt ctn 100104: Lenalidomide (len) vs. Placebo (pbo) maintenance therapy after single autologous stem cell transplant (asct) for multiple myeloma (mm). 2015. Journal of clinical oncology	Outcomes
4 9	Ishak et al. Adjusting for patient crossover in clinical trials using external data: A case study of lenalidomide for advanced multiple myeloma. 2011. Value in health	Outcomes
5 0	Jackson et al. Lenalidomide maintenance therapy post-autologous stem cell transplant: A healthcare cost-impact analysis in europe. 2017. Blood. Conference: 59th Annual Meeting of the American Society of Hematology, ASH. doi: --	Outcomes
5 1	Jackson et al. Lenalidomide maintenance versus observation for patients with newly diagnosed multiple myeloma (myeloma xi): A multicentre, open-label, randomised, phase 3 trial. 2019. Lancet oncology	Outcomes
5 2	Jackson et al. Productivity losses in patients with newly diagnosed multiple myeloma following stem cell transplantation and the impact of maintenance therapy. 2019. European Journal of Haematology. doi: https://dx.doi.org/10.1111/ejh.13298	Outcomes
5 3	Jagannath et al. Assessment of the impact of post-autologous stem cell transplant maintenance therapy on survival outcomes in patients with newly diagnosed multiple myeloma in the community-based connect mm registry. 2017. Haematologica	Outcomes
5 4	Jagannath et al. Impact of post-autologous stem cell transplant (asct) maintenance therapy on outcomes in patients (pts) with newly diagnosed multiple myeloma (ndmm) using the large prospective community-based connect mm registry. 2017. Journal of clinical oncology	Outcomes

5 5	Knauf et al. Lenalidomide plus dexamethasone for patients with relapsed or refractory multiple myeloma: Final results of a non-interventional study and comparison with the pivotal phase 3 clinical trials. 2018. Leukemia research	Outcomes
5 6	Leng et al. Factors associated with non-adherence to lenalidomide in patients with multiple myeloma. 2018. Journal of Clinical Oncology. Conference. doi: http://dx.doi.org/10.1200/JCO.2018.36.15_suppl.e20031	Outcomes
5 7	Man et al. The impact of maintenance therapy in the treatment of multiple myeloma with a subset analysis on patients who achieve a complete response (cr) or better: A retrospective analysis. 2017. Blood. Conference: 59th Annual Meeting of the American Society of Hematology, ASH. doi: --	Outcomes
5 8	McCarthy et al. Calgb/ecog 100104 (alliance) study: Lenalidomide (len) vs placebo (pbo) maintenance (maint) after stem cell transplant (sct) for patients (pts) with multiple myeloma-overall survival (os) and progression-free survival (pfs) adjusted for treatment (tx) crossover (xo). 2017. Journal of clinical oncology	Outcomes
5 9	McCarthy et al. Lenalidomide after stem-cell transplantation for multiple myeloma. 2012. New England journal of medicine	Outcomes
6 0	McCarthy et al. Lenalidomide maintenance vs placebo after stem cell transplant for patients with multiple myeloma: Overall survival and progression-free survival after adjusting for treatment crossover in calgb. 2017. Haematologica	Outcomes
6 1	McCarthy et al. Phase iii intergroup study of lenalidomide versus placebo maintenance therapy following single autologous hematopoietic stem cell transplantation (ahsct) for multiple myeloma: Calgb 100104. --. Blood	Outcomes
6 2	McCarthy et al. Phase iii intergroup study of lenalidomide versus placebo maintenance therapy following single autologous stem cell transplant (asct) for multiple myeloma (mm): Calgb ecog bmt-ctn 100104. 2011. Haematologica	Outcomes
6 3	Mina et al. Treatment intensification with autologous stem cell transplantation and lenalidomide maintenance improves survival outcomes of patients with newly diagnosed multiple myeloma in complete response. 2018. Clinical lymphoma, myeloma & leukemia	Outcomes
6 4	Niphadkar et al. Autologous stem cell transplant: A cost effective and efficacious treatment for newly diagnosed multiple myeloma. 2016. Blood. Conference: 58th Annual Meeting of the American Society of Hematology, ASH. doi: --	Outcomes
6 5	No Author. A prospective comparative study of safety of lenalidomide plus dexamethasone combination therapy versus vad (vincristine, doxorubicin and dexamethasone) regimen in the treatment of multiple myeloma. 2017. International journal of pharmaceutical sciences and research	Outcomes
6 6	No Author. Cc-5013 mm 0017: A multicenter, randomized, parallel-group, double-blind, placebo-controlled study of cc-5013 plus dexamethasone versus dexamethasone alone in previously treated subjects with multiple myeloma. 2003. Clinical advances in hematology & oncology	Outcomes

6 7	No Author. Phase i/ii trial of weekly bortezomib with lenalidomide and dexamethasone in first relapse or primary refractory myeloma. 2016. Haematologica	Outcomes
6 8	Oliva et al. Prognostic impact of minimal residual disease by aso-rq-pcr in multiple myeloma: A pooled analysis of 2 phase iii studies in patients treated with lenalidomide after front-line therapy. 2016. Blood	Outcomes
6 9	Palumbo et al. Autologous transplantation and maintenance therapy in multiple myeloma. 2014. New England journal of medicine	Outcomes
7 0	Palumbo et al. Cyclophosphamide-lenalidomide-dexamethasone vs asct, followed by maintenance with lenalidomide-prednisone vs lenalidomide alone in newly diagnosed mm patients: A phase 3 randomized emn trial. 2014. Bone marrow transplantation	Outcomes
7 1	Pulte et al. Fda approval summary: Lenalidomide as maintenance therapy after autologous stem cell transplant in newly diagnosed multiple myeloma. 2018. Oncologist	Outcomes
7 2	Stewart et al. Carfilzomib, lenalidomide, and dexamethasone for relapsed multiple myeloma. 2015. New England journal of medicine	Outcomes
7 3	Tzogani et al. The european medicines agency review of carfilzomib for the treatment of adult patients with multiple myeloma who have received at least one prior therapy. 2017. Oncologist	Outcomes
7 4	Weber et al. Lenalidomide plus dexamethasone for relapsed multiple myeloma in north america. 2007. New England journal of medicine	Outcomes
7 5	Abonour et al. Health-related quality of life of patients with newly diagnosed multiple myeloma receiving any or lenalidomide maintenance after autologous stem cell transplant in the connect mm disease registry. 2016. Blood. Conference: 58th annual meeting of the american society of hematology, ASH	Outcomes (Duplicate)
7 6	No Author. Cost-effectiveness analysis of lenalidomide for maintenance therapy after autologous stem cell transplant (asct) in newly diagnosed multiple myeloma (ndmm) patients: A united states payer perspective. 2018. Blood	Outcomes (Duplicate)
7 7	Blommestein et al. One line does not make a picture: Real-world cost-effectiveness of multiple myeloma treatments using a full disease model. 2013. Value in Health. doi: http://dx.doi.org/10.1016/j.jval.2013.08.490	Outcomes: conference abstract with no relevant results
7 8	Blommestein et al. Real-world evidence on healthcare resource use and associated cost with multiple myeloma in the netherlands. 2016. Value in Health. doi: --	Outcomes: conference abstract with no relevant results
7 9	Henk et al. Lenalidomide in myeloma treatment-impact of treatment persistence on disease control & healthcare resource utilization. 2013. Clinical Lymphoma, Myeloma and Leukemia. doi: --	Outcomes: conference abstract with

		no relevant results
80	Henk et al. Persistence to lenalidomide improves patient outcomes while remaining cost-neutral for the treatment of multiple myeloma. 2012. Blood. Conference: 54th Annual Meeting of the American Society of Hematology, ASH. doi: --	Outcomes: conference abstract with no relevant results
81	Sidi Mohamed El Amine et al. Financial toxicity of the management of multiple myeloma. 2017. Haematologica. doi: --	Outcomes: conference abstract with no relevant results
82	Addington-Hall and Altmann. Which terminally ill cancer patients in the united kingdom receive care from community specialist palliative care nurses?. 2000. Journal of advanced nursing. doi: --	Population
83	Blommestein et al. A cost-effectiveness analysis of real-world treatment for elderly patients with multiple myeloma using a full disease model. 2016. European Journal of Haematology. doi: https://dx.doi.org/10.1111/ejh.12571	Population
84	Chen et al. Cost-effectiveness of novel agents in medicare patients with multiple myeloma: Findings from a u.S. Payer's perspective. 2017. Journal of Managed Care and Specialty Pharmacy. doi: http://dx.doi.org/10.18553/jmcp.2017.23.8.831	Population
85	Dimopoulos et al. Impact of maintenance therapy on subsequent treatment in patients with newly diagnosed multiple myeloma: Use of "progression-free survival 2" as a clinical trial end-point. 2015. Haematologica	Population
86	Durie et al. Cost-effectiveness of treatments (tx) for newly-diagnosed multiple myeloma patients (ndmm pts). 2013. Clinical Lymphoma, Myeloma and Leukemia. doi: --	Population
87	Kim et al. Pharmacoeconomic implications of lenalidomide maintenance therapy in multiple myeloma. 2014. Oncology	Population
88	MacEwan et al. Assessing the economic burden in medicare patients with multiple myeloma. 2015. Blood. doi: --	Population
89	MacEwan et al. Economic burden of multiple myeloma among patients in successive lines of therapy in the united states. 2018. Leukemia and Lymphoma. doi: http://dx.doi.org/10.1080/10428194.2017.1361035	Population
90	Olszewski et al. Association of medicare part d coverage and low-income subsidies with use of novel oral agents in multiple myeloma. 2016. Blood. Conference: 58th Annual Meeting of the American Society of Hematology, ASH. doi: --	Population
91	Olszewski et al. Closure of medicare part d coverage gap by the affordable care act (aca) and use of oral anti-myeloma agents. 2017. Journal of Clinical Oncology. Conference. doi: --	Population

9 2	Burnette et al. Treatment trade-offs in myeloma: A survey of consecutive patients about contemporary maintenance strategies. 2013. Cancer. doi: http://dx.doi.org/10.1002/cncr.28340	Study design
9 3	Burnette et al. Treatment trade-offs in myeloma: A survey of consecutive patients. 2012. Blood. Conference: 54th Annual Meeting of the American Society of Hematology, ASH. doi: --	Study design
9 4	Cork et al. Analysis of the asco value framework net health benefit score as a tool for assessing novel therapies in relapsed/refractory multiple myeloma (rrmm). 2016. Value in health	Study design
9 5	Huntington et al. Financial toxicity in insured patients with multiple myeloma: A cross-sectional pilot study. 2015. The Lancet Haematology. doi: http://dx.doi.org/10.1016/S2352-3026%2815%2900151-9	Study design
9 6	No Author. Correction: Updated analysis of calgb (alliance) 100104 assessing lenalidomide versus placebo maintenance after single autologous stem-cell transplantation for multiple myeloma: A randomised, double-blind, phase 3 trial (the lancet haematology (2017) 4(9) (e431-e442), (s2352302617301400) (10.1016/s2352-3026(17)30140-0)). 2018. The lancet haematology	Study design
9 7	Paumgarten. Thalidomide and its analogues: Comparative clinical efficacy and safety, and cost-effectiveness. 2014. Cadernos de Saude Publica. doi: --	Study design
9 8	Richardson et al. Lenalidomide in multiple myeloma: An evidence-based review of its role in therapy. 2010. Core Evidence. doi: --	Study design

Appendix 3. Updated Prisma Diagram for quality of life studies

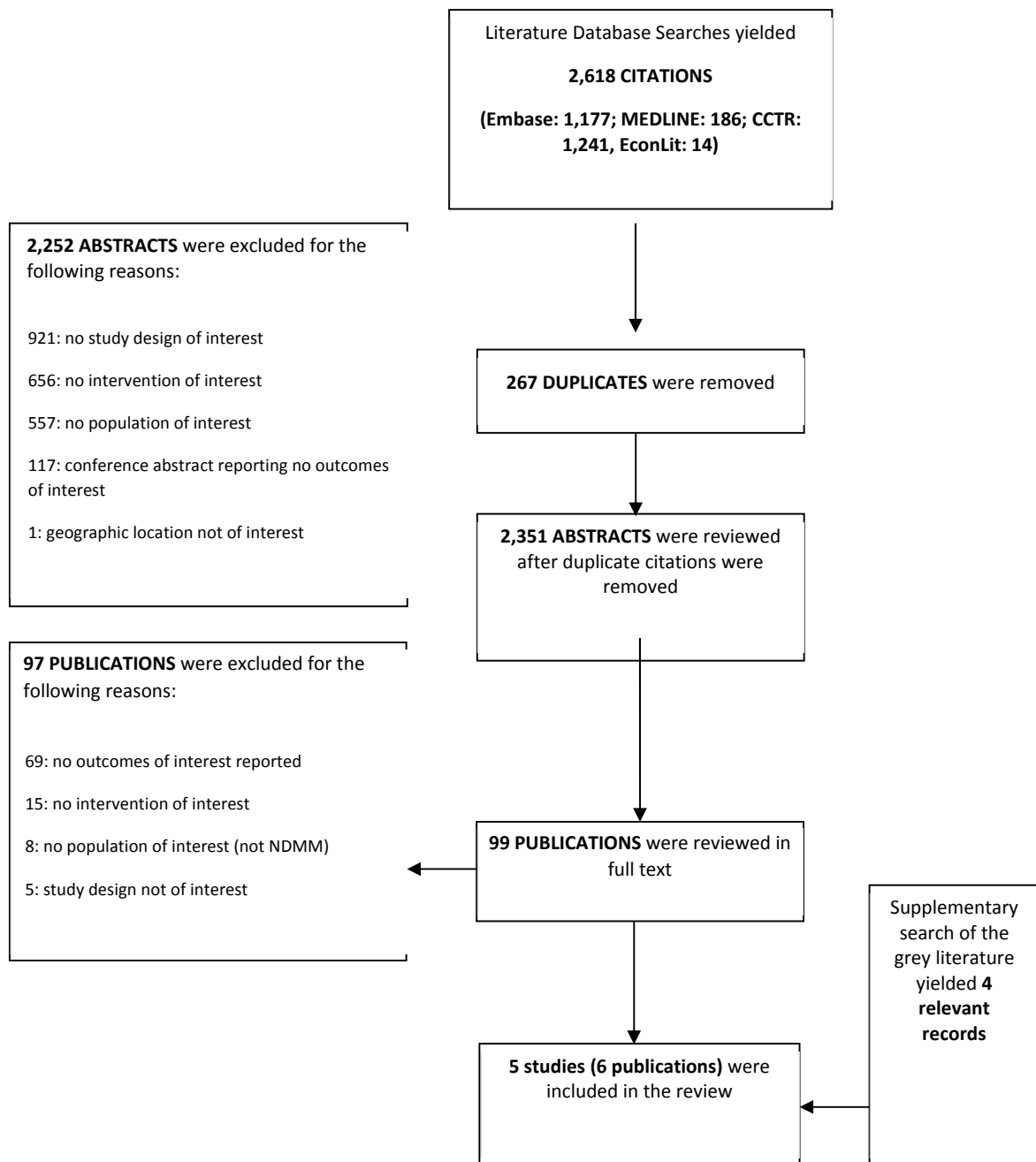

Patient organisation submission

Lenalidomide for the maintenance treatment of multiple myeloma after autologous stem cell transplantation [ID475]

Thank you for agreeing to give us your organisation's views on this technology and its possible use in the NHS.

You can provide a unique perspective on conditions and their treatment that is not typically available from other sources.

To help you give your views, please use this questionnaire with our guide for patient submissions.

You do not have to answer every question – they are prompts to guide you. The text boxes will expand as you type.

Information on completing this submission

- Please do not embed documents (such as a PDF) in a submission because this may lead to the information being mislaid or make the submission unreadable
- We are committed to meeting the requirements of copyright legislation. If you intend to include **journal articles** in your submission you must have copyright clearance for these articles. We can accept journal articles in NICE Docs.
- Your response should not be longer than 10 pages.

About you	
1. Your name	██████████
2. Name of organisation	Myeloma UK
3. Job title or position	████████████████████

<p>4a. Brief description of the organisation (including who funds it). How many members does it have?</p>	<p>Myeloma UK is the only organisation in the UK dealing exclusively with myeloma. Our broad and innovative range of services cover every aspect of myeloma from providing information and support, to improving standards of treatment and care through research and campaigning. We receive no government funding and rely almost entirely on the fundraising efforts of our supporters. We also receive some unrestricted educational grants and restricted project funding from a range of pharmaceutical companies. We are not a membership organisation.</p>																												
<p>4b. Has the organisation received any funding from the manufacturer(s) of the technology and/or comparator products in the last 12 months? [Relevant manufacturers are listed in the appraisal matrix.]</p> <p>If so, please state the name of manufacturer, amount, and purpose of funding.</p>	<p>The table below shows the audited 2018 income from the relevant manufacturer. Funding is received for a range of purposes and activities namely core grants, project specific work including clinical trials, and gifts, honoraria or sponsorship.</p> <table border="1" data-bbox="607 469 1272 954"> <thead> <tr> <th>Name of company</th> <th>Grants and Project Specific Funding</th> <th>Gifts, Honoraria and Sponsorship</th> <th>Total (£)</th> </tr> </thead> <tbody> <tr> <td>Amgen Ltd</td> <td>80,000</td> <td>204</td> <td>80,204</td> </tr> <tr> <td>Amgen Europe</td> <td>1,233</td> <td>14,935</td> <td>16,168</td> </tr> <tr> <td>Janssen-Cilag</td> <td>75,000</td> <td>-</td> <td>75,000</td> </tr> <tr> <td>Janssen Pharmaceutical</td> <td>212,230</td> <td>854</td> <td>213,084</td> </tr> <tr> <td>Celgene</td> <td>110,000</td> <td>12,691</td> <td>122,691</td> </tr> <tr> <td>Total</td> <td>478,463</td> <td>28,684</td> <td>507,147</td> </tr> </tbody> </table> <p>Figures for 2019 will be available in March 2020.</p>	Name of company	Grants and Project Specific Funding	Gifts, Honoraria and Sponsorship	Total (£)	Amgen Ltd	80,000	204	80,204	Amgen Europe	1,233	14,935	16,168	Janssen-Cilag	75,000	-	75,000	Janssen Pharmaceutical	212,230	854	213,084	Celgene	110,000	12,691	122,691	Total	478,463	28,684	507,147
Name of company	Grants and Project Specific Funding	Gifts, Honoraria and Sponsorship	Total (£)																										
Amgen Ltd	80,000	204	80,204																										
Amgen Europe	1,233	14,935	16,168																										
Janssen-Cilag	75,000	-	75,000																										
Janssen Pharmaceutical	212,230	854	213,084																										
Celgene	110,000	12,691	122,691																										
Total	478,463	28,684	507,147																										
<p>4c. Do you have any direct or indirect links with, or funding from, the tobacco industry?</p>	<p>No</p>																												
<p>5. How did you gather information about the experiences of patients and carers to include in your submission?</p>	<p>We designed and widely disseminated an online survey specifically to support this appraisal. The survey asked respondents general questions about their myeloma and what treatment outcomes were most important to them. Respondents were then split into those who had received lenalidomide maintenance (Group A) and those who had not (Group B). Group A were asked questions on their experience of receiving lenalidomide maintenance and Group B were asked questions based on comparative data for lenalidomide maintenance compared to the current standard treatment i.e. observation.</p>																												

	<p>Only patients who have received or are awaiting high-dose therapy and stem cell transplantation (HDT-SCT) were eligible to complete the survey. The survey was disseminated through our monthly e-newsletter and across our social media platforms (Facebook, LinkedIn, Twitter).</p> <p>There was a very significant response to the survey with 466 responses in total (305 full/161 partial). Twenty-eight per cent of survey respondents had also received lenalidomide maintenance (n= 129). This survey has therefore delivered important experience and insight data from a large number of patients whose clinical condition is highly relevant to the treatment being appraised.</p> <p>A full analysis of the survey can be found in appendix 1.</p> <p>Information in the survey has been augmented by insight and data gathered from our research programmes, including:</p> <ul style="list-style-type: none"> • A Myeloma UK patient experience survey of over 1,000 patients, conducted alongside the myeloma results of the National Cancer Patient Experience Survey. • A multi-criteria decision analysis study of 560 myeloma patients. The study, funded by Myeloma UK and run by the European Medicines Agency (EMA) and University of Groningen, explored patient preferences for different benefit and risk outcomes in myeloma treatment. <p>It has also been informed by the experiences and views of patients, family members and carers gathered through ongoing engagement with our Myeloma Infoline, Patient and Family Myeloma Infodays and online Discussion Forum.</p>
<p>Living with the condition</p>	
<p>6. What is it like to live with the condition? What do carers experience when caring for someone with the condition?</p>	<p>What is it like to live with myeloma?</p> <p><i>“Myeloma creeps up on you, engulfs you and, if you win the battle, leaves you wondering when it will come back.”</i></p> <p>Myeloma is a highly individual and complex cancer originating from abnormal plasma cells in the bone marrow. There is currently no cure, but treatment can halt its progress and improve quality of life. The complications of myeloma can be significant, debilitating and painful and include: severe bone pain, bone destruction, kidney damage, fatigue and a depleted immune system which can lead to increased infections.</p> <p>Myeloma is also a relapsing and remitting cancer which evolves over time and becomes resistant to treatment. Most patients can be successfully retreated at relapse; however, remission is usually associated with diminishing duration and depth of response over time.</p> <p>First remission is therefore widely held as the best opportunity to gain the deepest response with the longest period until disease progression.¹ It is also the point in their disease where many patients will be able to build on existing better quality of life since the burden of treatment and illness will be less than for patients who are multiply relapsed.</p>

¹ Bird and Boyd (2019) Multiple Myeloma: An Overview of Management Palliative Care and Social Practice 13:1-13 & Yong et.al (2016) Multiple Myeloma: Patient Outcomes in Real-World Practice Br J Heamatology 175:252-265

	<p>Treatment side-effects and frequent hospital visits have a social and practical impact on patients' lives, including significant financial implications. Reduction in mobility over time and a perceived increase in reliance on carers and family members, also impacts on patients' sense of control.</p> <p>What do carers experience?</p> <p><i>"I feel angry that I'm not going to get the future I wanted, but the hardest thing to feel is how my life at the moment is in limbo"</i></p> <p>A Myeloma UK study into the experiences of carers and family members found that looking after someone with myeloma has a significant emotional, social and practical impact: 25% of those in work had been unable to work or had to retire early to care for the person with myeloma; 84% always put the needs of their relative or friend with myeloma before their own; and 42% of carers were not given enough information at diagnosis about how myeloma may affect them.</p> <p>Living with myeloma is therefore often extremely challenging physically and emotionally for patients, carers and family members.</p>
<p>Current treatment of the condition in the NHS</p>	
<p>7. What do patients or carers think of current treatments and care available on the NHS?</p>	<p>Myeloma patients and their families and carers recognise the great strides that have been made in recent years in delivering access to effective myeloma treatments. However, a significant treatment and disease burden still exists.</p> <p>The highly individual and relapsing and remitting nature of myeloma means that a "head to head" comparison of treatments is not particularly helpful. In addition, for this particular appraisal, the comparator is likely to be observation. Therefore, rather than analyse the advantages and disadvantages of individual approved treatments we have set out below what is most important to patients in terms of treatment outcomes,</p> <p>Myeloma patients and their carers place a very high value on treatments that</p> <ul style="list-style-type: none"> • prolong their life • put their myeloma into remission for as long as possible • allow them to enjoy normal day-to-day life. <p>The Myeloma UK, EMA and the University of Groningen study showed that, achieving a lasting remission from treatment was the most important factor for most (75%) participants. This was true across all patient groups regardless of demographic and clinical characteristics.</p> <p>Treatments with minimal negative impact on quality of life are very important, particularly those with as few side-effects as possible and of low severity. That said, data shows that patients will accept even severe side effects if the treatment has a superior efficacy, suggesting that efficacy is the strongest driver of treatment choice.</p> <p><i>"The aim is to maintain the best possible quality of life for as long as possible."</i></p>

	<p>Finally, it is important to recognise that patients do not see the survival benefits of individual treatments in isolation. They want the best possible remission and quality of life at each stage of their myeloma and see gains in survival from one treatment as a “bridge” to further treatments coming down the line. This is highly relevant to this appraisal where there is the best chance of a durable remission extending best possible quality of life and where no treatment is currently approved for use on the NHS</p>
<p>8. Is there an unmet need for patients with this condition?</p>	<p>Yes.</p> <p>Studies show that in myeloma the first remission is often the deepest and longest remission period for the patient. Yet post HDT-SCT maintenance treatment is still not available; despite the substantial data which exists demonstrating the significant PFS gains it delivers.</p> <p>In addition, patients who receive an HDT-SCT are younger/fitter, more likely to be working and to have dependents and therefore face particular challenges in living with myeloma.</p> <p><i>“I have spoken to my consultant about the possible restriction on future treatments. But we are reassured that this first remission is so important, it is best that this is as long as possible, and during this time, different options for future treatment options continue to be developed.”</i></p> <p>Around 1,300 myeloma patients each year receive a SCT. If this treatment is not approved there will therefore be thousands of patients who have no option available to them to extend their most important remission, controlling their myeloma for the longest time possible.</p> <ul style="list-style-type: none"> • In our survey 98% of 294 patient respondents think that lenalidomide maintenance should be approved for use on the NHS. <p>In addition, while this data is informal, we have experienced a high level of interest and engagement through our services and information programmes from patients and their families about access to this treatment.</p>
<p>Advantages of the technology</p>	
<p>9. What do patients or carers think are the advantages of the technology?</p>	<p>Overall patient experience:</p> <p><i>“As well as the physical benefits of being on lenalidomide maintenance, the positive psychological impact it has on my quality of life is huge and shouldn’t be overlooked.”</i></p> <p>Our survey showed that patients saw a benefit to this treatment</p> <ul style="list-style-type: none"> • 90% of respondents who had received lenalidomide maintenance rated their experience as <i>very positive</i> or <i>positive</i> (59% <i>Very Positive</i> and 31% <i>Positive</i>) • 95% of respondents who had received lenalidomide maintenance would recommend this treatment option to other patients <p>Clinical trial data confirms that lenalidomide maintenance delivers the benefits which are most important to patients; improved OS, PFS and good quality of life.</p>

All respondents to the survey were asked to rank what is most important to them when being treated for myeloma. The data showed that **improved overall survival** was the most important factor for patients when being treated. This was closely followed by **increased remission** (progression free survival - PFS) **and improved quality of life**. These findings are in line with other research we have conducted (the EMA/ University of Groningen study).

Analysis of published clinical data and our survey results enables us to examine the extent to which lenalidomide maintenance delivers these key benefits.

Overall survival: Although median OS has not been reached in all of the trials. Lenalidomide maintenance following HDT-SCT has shown a significant OS benefit. An updated analysis from the CALGB trial (NCT00114101) reported a significant improvement in median OS of 29.7 months (after a median follow-up of 91 months) compared to placebo (hazard ratio 0.61; 95% CI, 0.46 to 0.80; $p < 0.0004$).² (A meta-analysis of the CALGB, IFM and GIMEMA clinical trials show that OS after a 7-year period was 62% for patients receiving lenalidomide maintenance and 50% for patients who were on observation/placebo.³ This is further supported by data from Myeloma XI which showed a significant improvement in 3-year overall survival 87.5% in the lenalidomide group and in the observation group (HR 0.69 [95% CI 0.52–0.93]; $p = 0.014$),⁴

Increased remission: A significant increase in median PFS has been observed in all four trials. In the meta-analysis patients receiving lenalidomide maintenance, median progression free survival (PFS) was doubled compared to observation/placebo (52.8 vs 23.5 months). This is further supported by the Myeloma XI data which reported an improvement in median progression-free survival compared to observation (57 months versus 30 months) (HR 0.48 [95% CI 0.40–0.58]; $p < 0.0001$).

Quality of life: Data indicates that lenalidomide maintenance does not negatively impact QoL. In our survey 63% of respondents who had received lenalidomide maintenance said that it did not impact at all on completing daily activities. This figure rises to 86.21% when we looked specifically at data for “working age” respondents (working full/part time, student, self-employed, homemaker or other.) This is further supported by analysis of data from the Connect MM registry which suggests lenalidomide-only maintenance does not negatively impact patients’ HRQoL⁵. The minimal toxicity profile of lenalidomide, particularly the reduced incidence of peripheral neuropathy, is also highly valued by patients. The oral regimen is easy to take and enables patients to have more control over their lives.

“I am so thankful for this maintenance drug as it’s helping me to stay in remission, the side effects are liveable.”

Given the relapsing and remitting nature of myeloma and the need to maximise the chance of effective treatment at each relapse, high response rates are of additional benefit to myeloma patients. Patients who achieve deep responses are more likely to experience longer PFS

² Holstein, S.A., et. al. 2017. Updated analysis of CALGB 100104 (Alliance): a randomised phase III study evaluating lenalidomide vs placebo maintenance after single autologous stem cell transplant for multiple myeloma. *The Lancet. Haematology*, 4(9), p.e431.

³ McCarthy, P.L., et. al., 2017. Lenalidomide maintenance after autologous stem-cell transplantation in newly diagnosed multiple myeloma: a meta-analysis. *Journal of Clinical Oncology*, 35(29), p.3279.

⁴ Jackson, G.H., et. al. 2019. Lenalidomide maintenance versus observation for patients with newly diagnosed multiple myeloma (Myeloma XI): a multicentre, open-label, randomised, phase 3 trial. *The Lancet Oncology*, 20(1), pp.57-73.

⁵ Abonour, R., et. al., 2018. Impact of post-transplantation maintenance therapy on health-related quality of life in patients with multiple myeloma: data from the Connect® MM Registry. *Annals of hematology*, 97(12), pp.2425-2436.

	<p>and OS. Trial data shows lenalidomide maintenance leads to higher number of patients achieving \geqVGPR. Furthermore, recent data has shown lenalidomide maintenance can lead to increased MRD negative rates. Our survey responses are in line with these findings with 88% of respondents to our survey who had received lenalidomide maintenance stating that it was effective in controlling their myeloma.</p> <p><i>“It greatly helped to restore my confidence that I could start to live a normal life whilst managing my myeloma, after the traumas of diagnosis, then chemo then the stem cell transplant. It gives me hope for future treatments being as easy and as effective.”</i></p> <p>These benefits also apply to carers and family members, for example:</p> <ul style="list-style-type: none"> • Improved psychological and emotional wellbeing knowing that the patient has effective treatment options. • Alleviation of symptoms and prevention of complications enables patients to be more independent and reduces day-to-day reliance on carers. • A good side-effect profile improves quality of life and improves patients’ ability to live a fuller life.
<p>Disadvantages of the technology</p>	
<p>10. What do patients or carers think are the disadvantages of the technology?</p>	<p>In our survey when asked to rank the disadvantages of lenalidomide maintenance, a majority of respondents said it had no disadvantages. However, a minority of respondents did highlight some disadvantages to the treatment which should be noted.</p> <p>Treatment Duration - As patients relapse and move onto further lines of treatment many new therapies are now classed as treat until progression. The initial treatment of HDT-SCT followed by observation gives patients, what may be for some, their last treatment free period. We know that being treatment free can be important to some patients.</p> <p>In our survey when we asked patients to rank the disadvantages of lenalidomide maintenance the treatment duration and no-treatment free period ranked 2nd and 3rd.</p> <p>We also asked patients who had not received lenalidomide maintenance to compare the data on the new treatment versus the current treatment and then make a choice between the two. In the survey, 22% of these respondents said they would choose observation following an HDT-SCT.</p> <p>Part of this question asked respondents to state why they made their choice. Analysis of these comments, showed that a majority of respondents who picked observation had what could be described as a good post HDT-SCT experience with a long remission period and good QoL.</p> <p><i>“At the moment I have a good quality of life in remission. I am concerned I would lose that quality of life with the side effects of the treatment.”</i></p> <p>Of those respondents who would choose observation, 92.5% still believed the option for maintenance treatment should be available on the NHS. This answer should also be considered alongside the finding that 95% of respondents who had received lenalidomide maintenance would recommend it to other patients.</p>

	<p><i>"I personally feel that the advantages outweigh the disadvantages and for me, would prefer to be able to access through the NHS rather than privately as now."</i></p> <p>Side effects – Data shows that the side effects of lenalidomide include low blood counts, risk of venous thromboembolism and blood clots, peripheral neuropathy and skin rashes.</p> <p>However, the majority of respondents to our survey who had received lenalidomide maintenance described their side effects as unaffected or mild. It is also useful to note that the most worrisome side effect for Group B, infection, was the least reported side effect from Group A respondents who had received the treatment.</p> <p><i>"I felt tired to begin with but I worked through that. I perhaps don't have as much energy as I might without it but it's not bad now. The worse thing for me is I get constipation and diarrhoea quite often and pain in my stomach but this is confined usually to evenings after taking the drug so does not impact on my daily life unduly."</i></p> <p>The side effects of lenalidomide are common to many if not most myeloma treatments. Many patients view it as something to be accepted and managed by clinical interventions and self-care strategies, as appropriate.⁶</p> <p>Furthermore, as referenced earlier in this submission, studies have shown that most myeloma patients would accept severe side-effects if the treatment had superior efficacy.⁷</p> <p><i>"The proven extension of remission is significant and quality of life during maintenance is good. The side effects can be controlled or minimised so, in my opinion the benefits outweigh the problems."</i></p>
<p>Patient population</p>	
<p>11. Are there any groups of patients who might benefit more or less from the technology than others? If so, please describe them and explain why.</p>	<p>As stated above lenalidomide maintenance will be post HDT-ASCT and therefore will benefit younger/fitter patients. Many of whom will still be of working age.</p> <p>Our survey enabled us to analyse the data for patients who were under the age of 60 and still in some form of work.</p> <p>The responses provided by patients who had received lenalidomide maintenance show that it is well tolerated by younger, fitter patients. The majority of which said the new treatment did not impact on their normal daily activities.</p> <p>A survey conducted in 2019 by Jackson and Galinsky et al looked at productivity losses in patients with newly diagnosed multiple myeloma following stem cell transplantation. There were 115 eligible survey respondents, 76.5% were economically active at the time of diagnosis and highlighted return to work as an important factor affecting their quality of life; only 39.1% of respondents were economically active post HDT-SCT.</p>

⁶ Cormican O et al (2018) Living with relapsed myeloma: Symptoms and self-care strategies J Clin Nurse 27(7–8): 1713–21.

⁷ Galinsky et al (2017) Myeloma Patient Value Mapping: A Discrete Choice Experiment Haematologica 102: 600-614 & D. Postmus et al (2018) Individual Trade-Offs Between Possible Benefits and Risks of Cancer Treatments: Results from a Stated Preference Study with Patients with Multiple Myeloma Oncologist 23(1): 44-51

	<p>Patients with myeloma aspire to engage in productive lives post-HDT-SCT, but most are unable to do so. Access to treatments extending remission and supporting engagement in a productive life can have a positive impact both for patients and wider society.⁸</p> <p><i>“Treatment regime was not very intrusive, allowed me to carry on working.”</i></p> <p>Lenalidomide maintenance can give increased OS and PFS with low level of side effects. The addition of lenalidomide maintenance to the current treatment regime could help patients to return to some kind of work and retain a relatively high QOL.</p> <p><i>“I am 50 years old with a teenage daughter and therefore have a lot to live for. Any opportunity to have increased survival rate regardless of side effects is an option I would take. I already live with a number of side effects and would not see the new treatment as a negative.”</i></p>
<p>Equality</p>	
<p>12. Are there any potential equality issues that should be taken into account when considering this condition and the technology?</p>	<p>No</p>
<p>Other issues</p>	
<p>13. Are there any other issues that you would like the committee to consider?</p>	

⁸ Jackson G, Galinsky J, Alderson DEC, et al. Productivity losses in patients with newly diagnosed multiple myeloma following stem cell transplantation and the impact of maintenance therapy. Eur J Haematol. 2019;103: 393–401. <https://doi.org/10.1111/ejh.13298>

14. To be added by technical team at scope sign off. Note that topic-specific questions will be added only if the treatment pathway or likely use of the technology remains uncertain after scoping consultation, for example if there were differences in opinion; this is not expected to be required for every appraisal.]
if there are none delete highlighted rows and renumber below

Key messages

15. In up to 5 bullet points, please summarise the key messages of your submission:

- There is a clear unmet need for this treatment. In myeloma the first remission is often the deepest and longest remission period for the patient. Yet post HDT-SCT maintenance treatment is still not available.
- The Myeloma UK Patient Treatment Survey overwhelmingly shows that patients who received lenalidomide maintenance had a positive experience and would recommend it as a treatment option to other patients.
- Clinical trial data and our survey confirm that lenalidomide maintenance delivers the benefits which are most important to patients; improved OS, improved PFS and good Quality of Life.
- Although median OS has not been reached in clinical trials the treatment has shown a significant OS benefit. A substantial increase in median PFS has also been observed in all four key trials. For example, in Myeloma XI PFS was almost doubled to 57 months. For an incurable cancer like Myeloma this represents an exceptional clinical benefit.
- Data from the clinical trials and our survey shows that lenalidomide maintenance does not negatively impact on quality of life. The patient population for this treatment will include a high proportion of younger/fitter patients. This treatment could help patients return to some form of work and retain a relatively high quality of life.

Thank you for your time.

Please log in to your NICE Docs account to upload your completed submission.

Your privacy

The information that you provide on this form will be used to contact you about the topic above.

Please tick this box if you would like to receive information about other NICE topics.

For more information about how we process your personal data please see our [privacy notice](#).

.....

Lenalidomide Maintenance Patient Treatment Survey Results

Summary

The Myeloma UK Patient Treatment survey was designed to capture patient insight and information on lenalidomide maintenance for the upcoming NICE and the SMC appraisals.

As this new treatment is being licensed for post high-dose therapy and stem cell transplantation (HDT-SCT) the survey was only open to patients who had received or were awaiting an HDT-SCT.

The survey asked a mixture of general questions about the patient and their myeloma and specific questions on lenalidomide maintenance.

Respondents were split into two groups:

- A - Patients who had received lenalidomide maintenance through a clinical trial or paid for access privately
- B - Patients who had not received lenalidomide maintenance following an HDT-SCT and patients who were newly diagnosed currently waiting on an HDT-SCT.

Patients who fell into group A were asked questions about their experience of lenalidomide maintenance.

Patients who were in group B were provided with information and data from a meta-analysis of clinical trials comparing lenalidomide maintenance post HDT-SCT to observation post HDT-SCT. They were then asked questions on both treatment options.

Questions on both groups will allow for comparisons between both sets of patients.

NB – Only two questions were mandatory, therefore not every question was answered by each participant. This was to ensure that the survey was accessible to all patients. In the following analysis the number of respondents who answered each question will be presented alongside the data.

Key findings:

- 466 respondents submitted full/partial information to the survey.
- 97.61% of 294 respondents think that lenalidomide should be approved for use on the NHS.
- 90.29% of respondents who had received lenalidomide maintenance rate it as either *Very Positive* or *Positive*.
- 88.24% of respondents who had received lenalidomide maintenance felt that it was effective in controlling their myeloma.
- 95.1% of respondents who had received lenalidomide maintenance would recommend this treatment option to other patients.

- Based on the information provided, 78.35% of patients who had not received lenalidomide maintenance would choose this new treatment over the current standard treatment of observation post HDT-SCT.
- When asked to rank the disadvantages of lenalidomide maintenance, a majority of respondents said that it had no disadvantages.
- 95.86% of patients had received treatment for their myeloma with 62.58% currently receiving some form of treatment, meaning that this is an informed patient group.

Quotes from Patients who had received lenalidomide maintenance post HDT-SCT

"It greatly helped to restore my confidence that I could start to live a normal life whilst managing my myeloma, after the traumas of diagnosis, then chemo then the stem cell transplant. It gives me hope for future treatments being as easy and as effective."

"I am so thankful for this maintenance drug as it's helping me to stay in remission, the side effects are liveable."

"I have spoken to my consultant about the possible restriction on future treatments. But we are reassured that this first remission is so important, it is best that this is as long as possible, and during this time, different options for future treatment options continue to be developed."

"I felt tired to begin with but I worked through that. I perhaps don't have as much energy as I might without it but it's not bad now. The worse thing for me is I get constipation and diarrhoea quite often and pain in my stomach but this is confined usually to evenings after taking the drug so does not impact on my daily life unduly."

"I personally feel that the advantages outweigh the disadvantages and for me, would prefer to be able to access through the NHS rather than privately as now."

"Very few minor side effects, increased wellbeing physically and psychologically, keeping me in remission."

Quotes from patients who had not received lenalidomide maintenance post HDT-SCT

"Psychological benefit of having lenalidomide maintenance given research evidence of its efficacy is of overriding importance to me. It was extremely stressful not having maintenance and worrying about relapse. For me having the best available treatment for this incurable disease is psychologically all important."

"This is a terminal illness and for myself in my 40s with two small children I want to do everything possible to extent my life and raise my children."

"Due to personal circumstances I want to be treatment free even if this means a shorter life expectancy. Quality of life is by far the most important factor for me."

Patient Treatment Benefits

The first section of the survey focused on general questions about participants' myeloma. This was before any information had been presented about the new treatment. Question 5 of the survey asked all participants to rank what is most important to them when being treated for Myeloma. The full data can be found in table 1 below:

Q5 What is most important to you when being treated for myeloma? (Please rank 1 most - 5 least)

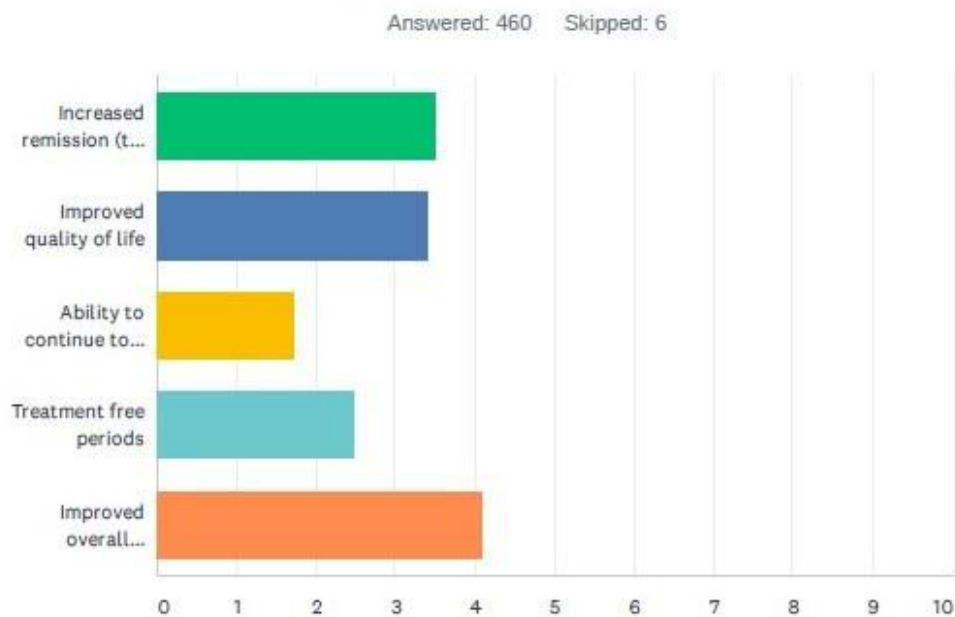

	1	2	3	4	5	TOTAL	SCORE
Increased remission (time between myeloma relapses)	19.30% 77	35.84% 143	25.81% 103	13.78% 55	5.26% 21	399	3.50
Improved quality of life	19.47% 81	26.92% 112	34.13% 142	13.94% 58	5.53% 23	416	3.41
Ability to continue to work	6.38% 27	5.67% 24	7.33% 31	14.66% 62	65.96% 279	423	1.72
Treatment free periods	6.65% 27	10.59% 43	21.92% 89	43.35% 176	17.49% 71	406	2.46
Improved overall survival	56.12% 234	17.27% 72	10.55% 44	10.31% 43	5.76% 24	417	4.08

Table 1 – Patient Treatment Benefits

Analysis: The average ranking for each answer choice can be calculated so you can determine which was most preferred overall. The answer choice with the largest average ranking is the most preferred choice.

The data from Question 5 shows that improved overall survival (OS) is the most important factor for patients when being treated. This was closely followed by increased remission (progression free survival - PFS) and improved quality of life.

The findings of available clinical trial data confirm that lenalidomide maintenance delivers the benefits which are most important to patients in the survey.

This correlation can be seen across both OS and PFS.

OS has not been reached in many of the trials. However, a meta-analysis of the CALGB, IFM and GIMEMA clinical trials show that OS after a 7-year period was 62% for patients receiving lenalidomide maintenance and 50% for patients who were on observation/ placebo. This is further supported by data from Myeloma XI which showed a significant improvement in 3-year overall survival (87.5%) in the lenalidomide group and in the observation group.

For patients receiving lenalidomide maintenance, average progression free survival (PFS) was 52.8 months. This is compared to an average PFS of 23.5 months for the patients on observation/placebo. This is further supported by the Myeloma XI data which reported an improvement in median progression-free survival compared to observation (57 months versus 30 months).

Lenalidomide maintenance delivers preferred patient treatment outcomes as it increases OS and PFS compared to the current treatment option of observation post HDT-SCT.

Comparator Information

Following general questions about the patient's myeloma Questions 7 and 8 were designed to distinguish patients between two groups: A and B.

The survey was for patients who had received or were awaiting an HDT-SCT only.

Question 7 asked *"As part of your initial treatment for myeloma (1st line) did you receive high-dose therapy and stem cell transplantation?"*

- 395 (out of 466) responses indicated that they had received a stem cell transplant and 30 (466) indicated they were currently awaiting an SCT. The final 41 (466) said they did not receive an SCT and were referred to the disqualification page.

Question 8 was then asked to differentiate patients between group A and B. It asked *"As part of your initial treatment for myeloma (1st line), did you receive lenalidomide maintenance following high dose therapy and stem cell transplantation?"*

- 129 (466) indicated that they had received lenalidomide maintenance following their HDT-SCT. For the other responders, 293 (466) said they had not received

lenalidomide maintenance post HDT-SCT, 27 (466) indicated they were currently awaiting an HDT-SCT, the final 17 (466) indicated they that this was Not Applicable (N/A) to them.

Therefore, following both mandatory questions:

- Group A - 129 were eligible to answer the questions on their experience of lenalidomide maintenance. (An average of 90 respondents completed all 14 questions on group A)
- Group B - 337 were eligible to answer the questions comparing lenalidomide maintenance vs observation. (An average of 195 completed all 5 questions on group B).

Survey Analysis – Comparison Questions

Eight questions in the survey were designed to provide comparator information between group A and group B. This compared the benefits of lenalidomide maintenance, side effects, the benefits of lenalidomide maintenance vs the benefits of the current treatment (observation), and whether lenalidomide maintenance should be approved for use within the NHS.

Benefits of lenalidomide maintenance

Question 17 and Question 23 asked respondents in group A and group B to rank the benefits of lenalidomide maintenance from 1 most beneficial to 7 least beneficial with a further option for non-applicable.¹

Benefits of lenalidomide maintenance	Group A – (100)	Group B – (195)
Long remission period	6.11	5.96
Easy to take (oral treatment)	4.97	4.33
Improved quality of life	5.25	4.38
It had little side effects/level of side effects	4.38	3.26
Treatment duration	3.20	3.21
It has no benefit	2.51	1.70
Effective control of myeloma	N/A	5.85
Fewer hospital visits	3.35	N/A

Table 2 – Benefits of lenalidomide maintenance across Group A and Group B

¹ Ranking questions calculate the average ranking for each answer choice so you can determine which answer choice was most preferred overall. The answer choice with the largest average ranking is the most preferred choice.

Analysis: From the data provided a *long remission period* was given the highest score across both groups (A-6.11 and B-5.96), followed by *improved quality of life* (A- 5.25 and B-4.38) and third was *easy to take* (A-4.97 and B-4.33).

The lowest ranked choices were that *it has no benefit* (A-2.51 and B-1.70) and *Treatment Duration* (A-3.20 and B-3.21).

In group B effective control of Myeloma was the second highest ranked benefit attributed to lenalidomide maintenance with a score of 5.85. For group A this was asked in a separate question: “Do you feel lenalidomide maintenance is/was effective in controlling your myeloma?” 102 respondents answered with 90 responding that it was effective in controlling their myeloma.

Side effects of lenalidomide maintenance

Question 12 and question 25 asked about the side effects of lenalidomide maintenance.

For group A, question 12 asked respondents to describe the side effects they experienced while taking lenalidomide maintenance between unaffected, mild, serious and severe. (The results are presented in table 3.)

For group B patients were asked in Question 25 to rank the most worrying side effects from 1 most to 8 least. These side effects were taken from the meta-analysis data and differ from the data used for group A. (The results are presented in table 4.)

Myeloma UK Patient Treatment Survey

	UNAFFECTED	MILD	SERIOUS	SEVERE	TOTAL
Low white blood cell count (neutropenia)	37.37% 37	50.51% 50	11.11% 11	1.01% 1	99
Anaemia	64.52% 60	33.33% 31	2.15% 2	0.00% 0	93
Low platelet count (thrombocytopenia)	65.66% 65	24.24% 24	9.09% 9	1.01% 1	99
Infection	36.17% 34	53.19% 50	7.45% 7	3.19% 3	94
Numbness, tingling or pain in the hands or feet (peripheral neuropathy)	45.10% 46	40.20% 41	8.82% 9	5.88% 6	102
Nausea, diarrhoea and/or constipation (gastrointestinal disorder)	32.35% 33	47.06% 48	14.71% 15	5.88% 6	102
Fatigue	18.45% 19	60.19% 62	17.48% 18	3.88% 4	103
Skin rashes	73.27% 74	18.81% 19	5.94% 6	1.98% 2	101
Blood clots (venous thromboembolic events)	89.00% 89	5.00% 5	5.00% 5	1.00% 1	100

Table 3 – Patient experience of lenalidomide maintenance side effects

	1	2	3	4	5	6	7	8	TOTAL	SCORE
Low blood count	14.29% 26	15.93% 29	13.19% 24	18.13% 33	16.48% 30	7.69% 14	8.79% 16	5.49% 10	182	5.08
Infection	24.19% 45	25.27% 47	16.13% 30	13.98% 26	13.44% 25	4.84% 9	2.15% 4	0.00% 0	186	6.10
Numbness, tingling or pain in the hands or feet (peripheral neuropathy)	16.22% 30	11.89% 22	22.70% 42	16.76% 31	13.51% 25	10.81% 20	5.41% 10	2.70% 5	185	5.33
Nausea, diarrhoea and/or constipation (gastrointestinal disorder)	4.86% 9	14.05% 26	15.14% 28	15.68% 29	15.68% 29	17.30% 32	10.81% 20	6.49% 12	185	4.49
Fatigue	8.95% 17	9.47% 18	12.63% 24	13.68% 26	21.05% 40	16.32% 31	11.58% 22	6.32% 12	190	4.45
Skin rashes	0.53% 1	0.53% 1	1.60% 3	3.74% 7	4.28% 8	21.93% 41	31.55% 59	35.83% 67	187	2.18
Blood clots	7.53% 14	17.20% 32	11.29% 21	14.52% 27	11.29% 21	16.13% 30	17.20% 32	4.84% 9	186	4.54
Developing another cancer	28.19% 53	7.98% 15	9.04% 17	5.32% 10	5.32% 10	4.79% 9	11.70% 22	27.66% 52	188	4.49

Table 4 – Patients most worrisome side effects of lenalidomide maintenance

Analysis: The majority of respondents in Group A described their side effects as unaffected or mild.

Seven out of eight side effects were consistent across both questions allowing us to make a comparison between both groups.

The most worrisome side effect for respondents in group B was the increased risk of infection. It should be noted that infection was the least reported side effect by respondents in Group A.

There is one clear difference between the questions as Question 25 for Group B had an extra side effect choice of *Developing Another Cancer*. This was included after it was reported in the meta-analysis of clinical trial data for lenalidomide maintenance. In the results it can be seen that this was the joint 5th most worrisome side effect for patients in Group B.

Benefits of lenalidomide maintenance vs observation in Group B

Questions 23 and 24 asked Group B to rank the benefits of lenalidomide maintenance and the benefits of observation.

Benefits	Lenalidomide Maintenance – (195)	Observation – (197)
Long remission period	5.96 (1 st)	3.50 (5 th)
Easy to take	4.33 (4 th)	
Improved quality of life	4.38 (3 rd)	4.23 (2 nd)
Effective control of myeloma	5.85 (2 nd)	3.97 (4 th)
Treatment duration	3.21 (6 th)	N/A
Level of side effects	3.26 (5 th)	4.44 (1 st)
It has no benefit	1.70 (7 th)	1.91 (6 th)
Treatment free period	N/A	3.99 (3 rd)

Table 5 – Benefits of treatment options presented to Group B

Analysis: The main benefit for lenalidomide maintenance is the long remission period and the main benefit for observation was the level of side effects (i.e. there being no side effects).

Approved on the NHS

Questions 22 and 27 asked respondents in both group A and Group B *“Do you think lenalidomide maintenance should be approved for use on the NHS?”*

Approved through the NHS	Group A - 99	Group B - 195	Total – 294 (63% of total survey respondents)
Yes	96.97%	97.5%	97.61%
No	3.03%	2.05%	2.38%

Table 6 – NHS Approval

Analysis: A clear majority in both groups feel that this should be approved for use on the NHS.

Survey Analysis – Sub-Sections

The survey also enables an analysis of key identified population subsets.

As lenalidomide maintenance is a new treatment for newly diagnosed patients post HDT-SCT it may have a significant impact on younger and/or fitter patients. There are no rigid age cut-offs for an HDT-SCT but if you are over the age of 65–70 years or if your

general health is not good (i.e. older and/or less fit), you would not normally be a candidate.

Therefore, a high proportion of patients who receive lenalidomide maintenance will be younger and potentially of working age. We analysed the data for respondents who were under the age of 60 and still working (full/part time, student, self-employed, homeworker and other).

A further sub-set of patients identified through survey were respondents in Group B who were presented with clinical trial data comparing both treatments and would choose observation as their preferred option.

Finally, we compared the general characteristics of respondents between Group A and Group B.

Patients who are young and of working age

As said above, lenalidomide maintenance is for post HDT-SCT and will therefore be mainly used by younger patients who could still be working. The survey enabled us to analyse the responses of patients who were under the age of 60 and still working (full/part time, student, self-employed, homeworker and other).

Through applying this filter, the survey has 82 responses which fit these criteria.

- A majority of this group are newly diagnosed (70.51%) or have relapsed once (20.51%).
- 64.63% are currently receiving treatment and 35.37% are not receiving treatment.
- Patient treatment preference mirrors the whole survey population with improved overall survival and increased remission time being most important when being treated for myeloma.
- 28 respondents (34.15%) who were younger and of working age had received lenalidomide maintenance following an HDT-SCT (Group A.) The other 54 respondents either did not receive the treatment or were currently awaiting an HDT-SCT (Group B.)

Group A

- 93.1% rated their overall experience of lenalidomide maintenance as being very positive or positive.
- 89.66% said lenalidomide maintenance was/is effective in controlling their Myeloma
- 96.5% would recommend lenalidomide maintenance to other patients.
- 86.21% said that the treatment did not impact at all on completing normal daily activities. The other 13.79% said that the treatment partially stopped

them from completing normal daily activities. No responses indicated that the treatment entirely stopped them from completing normal daily activities.

- 79.31% of respondents said they had no hospital admissions directly related to their treatment.
- A majority of responses ranked a long PFS as the most important benefit of lenalidomide maintenance with easy to take and that it had little side effects coming second and third.
- When asked to rank the disadvantages of lenalidomide maintenance the majority of responses indicated that there were no disadvantages. This was followed in joint second with treatment duration and having no treatment free period.
- 100% of participants felt that lenalidomide maintenance should be approved for use within the NHS.

Group B

There were 54 respondents who were younger and of working age in group B. Patients in this group were shown data from a meta-analysis of clinical trial data on lenalidomide maintenance vs observation.

- When asked to rank the benefits of lenalidomide maintenance a majority of respondents ranked long remission period and effective control of myeloma as the most important.
- When asked to rank the benefits of observation the majority respondents ranked no treatment related side effects and an improved/normal quality of life as the most important.
- When asked to rank the most worrisome side effects of lenalidomide maintenance respondents ranked infection and peripheral neuropathy as the most worrisome.
- Based on the information provided, if given the option between lenalidomide maintenance and observation, 69.81% chose the new treatment against 28.30% who would choose the current treatment.
- 96.23% of respondents felt that lenalidomide maintenance should be approved for use within the NHS.

Analysis

- The responses provided by group A show that lenalidomide maintenance is well tolerated by younger, fitter patients. The majority of which said the new treatment did not impact on their normal daily activities.
- A survey conducted in 2019 by Jackson and Galinsky et Al looked at productivity losses in patients with newly diagnosed multiple myeloma following stem cell transplantation. There were 115 eligible survey respondents, 76.5% were

economically active at the time of diagnosis and highlighted return to work as an important factor affecting their quality of life; only 39.1% of respondents were economically active post HDT-SCT.

- Patients with myeloma aspire to engage in productive lives post-HDT-SCT, but most are unable to do so. Access to treatments extending remission and supporting engagement in a productive life can have a positive impact both for patients and wider society.²
- Lenalidomide maintenance can give increased OS and PFS with low level of side effects. The addition of lenalidomide maintenance to the current treatment regime could help patients to return to some kind of work and retain a relatively high HRQOL.

Observation

Group B were presented with information on lenalidomide maintenance and information on observation. After receiving information and answering questions 40 respondents out of 194 indicated that they would choose observation. Can the data from the rest of the survey responses tell us why?

- Age – respondents in this group ranged from 30-39 (2 respondents), 40-49 (3), 50-59 (13), 60-69 (15) and 70-79 (7).
- 17 of respondents were retired with 14 either working FT, working PT or self-employed.
- A majority of 23 (65.71%) were newly diagnosed.
- 75% were not currently receiving treatment.
- When ranking what is most important when being treated improved overall survival was most important followed closely by increased remission time and an improved quality of life.
- When asked to rank the benefits of lenalidomide maintenance respondents selected long remission period, effective control of myeloma and easy to take as their three most important.
- When asked to rank the benefits of observation the top two ranked choices were no treatment related side effects followed by a treatment free period.
- Whilst this collection of respondents would choose observation over maintenance treatment, 92.50% of respondents said that they think lenalidomide maintenance should be approved for use within the NHS.
- When asked why they would choose observation many patients said that the risk of side effects would put them off. Many were already on observation with a long remission period and enjoying a treatment free period.

² Jackson G, Galinsky J, Alderson DEC, et al. Productivity losses in patients with newly diagnosed multiple myeloma following stem cell transplantation and the impact of maintenance therapy. *Eur J Haematol.* 2019;103: 393–401. <https://doi.org/10.1111/ejh.13298>

Analysis: The characteristics of patients in this group were similar to the whole survey.

Many patients in this group could be classed as having a good experience on the current treatment regime of HDT-SCT followed by observation. The long remission times alongside the absence of any treatment related side effects could have been a factor in their opinion.

It is significant that a large majority of patients felt that even though they would pick observation the option for maintenance treatment should be available within the NHS.

Characteristics between Group A and Group B

Characteristics	Group A (129)	Group B (337)
Age	99 Responses	205 Responses
20-29	0 (0%)	1 (0.49%)
30-39	1 (1.01%)	6 (2.93%)
40-49	16 (16.16%)	18 (8.78%)
50-59	23 (23.23%)	63 (30.73%)
60-69	36 (36.36%)	77 (37.56%)
70-79	23 (23.23%)	38 (18.54%)
80+	0 (0%)	2 (0.98%)
Gender	99 Responses	204 Responses
Female	43 (43.34%)	91 (44.61%)
Male	56 (56.57%)	113 (55.39%)
Employment Status	100 Responses	205 Responses
Working full time	15 (15%)	30 (14.63%)
Working part time	11 (11%)	10 (4.88%)
Self-employed	5 (5%)	14 (6.83%)
Student	0 (0%)	0 (0%)
Unemployed	0 (0%)	1 (0.49%)
Unable to work	11 (11%)	37 (18.05%)
Stay at home parent	1 (1%)	3 (1.46%)
Retired	55 (55%)	103 (50.24%)
Other	2 (2%)	7 (3.41%)
Stage of myeloma	106 Responses	313 Responses
Newly diagnosed	64 (60.38%)	143 (45.69%)
Relapsed once	22 (20.75%)	100 (31.95%)
Relapsed twice	11 (10.38%)	38 (12.14%)
Relapsed three times	5 (4.72%)	23 (7.35%)
Relapsed four or more times	4 (3.77%)	9 (2.88%)

Table 7 – Characteristics between Group A and Group B

Analysis: The population characteristics between both groups are broadly similar. However, one key difference is that a higher percentage of patients in group A who had received lenalidomide maintenance were newly diagnosed and had not yet relapsed compared to Group B.

Conclusion

The Myeloma UK Patient Treatment Survey on lenalidomide maintenance aimed to capture patient experience and opinion on this new treatment.

The respondents to this survey fell into two broad categories: Those who had received lenalidomide maintenance post HDT-SCT and those who had been on the current treatment of observation post HDT-SCT.

These patients' insights are hugely valuable as they capture the experience of both treatment options.

The findings of this survey will be used to inform Myeloma UK's evidence submission to the upcoming NICE and SMC appraisals.

Professional organisation submission

Lenalidomide for the maintenance treatment of multiple myeloma after autologous stem cell transplantation [ID475]

Thank you for agreeing to give us your organisation's views on this technology and its possible use in the NHS.

You can provide a unique perspective on the technology in the context of current clinical practice that is not typically available from the published literature.

To help you give your views, please use this questionnaire. You do not have to answer every question – they are prompts to guide you. The text boxes will expand as you type.

Information on completing this submission

- Please do not embed documents (such as a PDF) in a submission because this may lead to the information being mislaid or make the submission unreadable
- We are committed to meeting the requirements of copyright legislation. If you intend to include **journal articles** in your submission you must have copyright clearance for these articles. We can accept journal articles in NICE Docs.
- Your response should not be longer than 13 pages.

About you	
1. Your name	[REDACTED]
2. Name of organisation	Royal College of Pathologists/ UK Myeloma Forum/ BSH

3. Job title or position	[REDACTED]
4. Are you (please tick all that apply):	<input type="checkbox"/> an employee or representative of a healthcare professional organisation that represents clinicians? <input checked="" type="checkbox"/> a specialist in the treatment of people with this condition? <input type="checkbox"/> a specialist in the clinical evidence base for this condition or technology? <input type="checkbox"/> other (please specify):
5a. Brief description of the organisation (including who funds it).	The Royal College of Pathologists is a professional membership organisation committed to promoting excellence in the practice of pathology. Its main function is the overseeing of postgraduate training, and its Fellowship Examination (FRCPath) is recognised as the standard assessment of fitness to practise in this branch of medicine.
4b. Has the organisation received any funding from the manufacturer(s) of the technology and/or comparator products in the last 12 months? [Relevant manufacturers are listed in the appraisal matrix.] If so, please state the name of manufacturer, amount, and	No

purpose of funding.	
5c. Do you have any direct or indirect links with, or funding from, the tobacco industry?	No
The aim of treatment for this condition	
6. What is the main aim of treatment? (For example, to stop progression, to improve mobility, to cure the condition, or prevent progression or disability.)	Multiple myeloma is incurable so the aims of treatment are 1) to prolong survival (OS) 2) to prolong time until disease progression (Progression free survival - PFS) 3) to maintain / improve quality of life (i.e part of QALY)
7. What do you consider a clinically significant treatment response? (For example, a reduction in tumour size by x cm, or a reduction in disease activity by a certain amount.)	Improvement in PFS and/or OS whilst maintaining quality of life.
8. In your view, is there an	Yes as the disease is incurable and life limiting, any treatment that prolongs time to disease

<p>unmet need for patients and healthcare professionals in this condition?</p>	<p>progression and/or survival with acceptable side effects will help meet an unmet need</p>
<p>What is the expected place of the technology in current practice?</p>	
<p>9. How is the condition currently treated in the NHS?</p>	<p>Currently there is no maintenance therapy following an autologous stem cell transplant so the comparator for this appraisal is no treatment</p> <p>Currently fit patients will be considered for an autologous stem cell transplant following a period of induction chemotherapy</p> <p>There is no fixed definition of fit but it is uncommon to offer transplant to patients if they have significant comorbidities.</p> <p>Overall a third of myeloma patients receive an autologous stem cell transplant (ASCT)</p> <p>ASCT is commissioned by NHS England as Standard of care for consolidation following induction treatment in newly diagnosed patients established both before the era of novel agent treatment in large randomised trials (Attal, 1996; Harousseau, 2005; Child , 2003; Femand et al, 1998; Blade et al, 2001) and in the era of novel agents (REF)</p>
<ul style="list-style-type: none"> Are any clinical guidelines used in the treatment of the condition, and if so, which? 	<p>There are European Guidelines (Moreau <i>et al</i>, 2017 - ESMO 2017), ASCO guidelines (Mikhael <i>et al</i>, JCO 2019) and International Myeloma Working Group (Ludwig H <i>et al</i>, Blood 2012) – all recommend maintenance lenalidomide</p> <p>The British Society of Haematology guidelines are currently being revised in light of new data and will recommend lenalidomide maintenance (I am a co-author)</p>

<ul style="list-style-type: none"> Is the pathway of care well defined? Does it vary or are there differences of opinion between professionals across the NHS? (Please state if your experience is from outside England.) 	<p>There is no standard maintenance currently used in the NHS so “pathway of care” post transplant management is just observation</p> <p>The pathway of myeloma treatment is complex especially at relapse and hard to define. It changes frequently as new TAs becomes appraised by NICE (for example there were 3 TAs approved in 2019 that altered treatment algorithm). I do not think there is much differences in opinion between professionals but clinicians get very frustrated by being forced to treat patients identically when clearly this is a heterogeneous disease</p>
<ul style="list-style-type: none"> What impact would the technology have on the current pathway of care? 	<p>It would impact as patients receiving lenalidomide maintenance are likely to progress on lenalidomide (only exceptions would be if it was stopped for intolerance or patient wishes).</p> <p>This would realistically exclude patients from receiving lenalidomide at 2nd or 3rd line</p>
<p>10. Will the technology be used (or is it already used) in the same way as current care in NHS clinical practice?</p>	<p>There is no standard maintenance currently used in the NHS so the comparator is no treatment</p> <p>Earlier studies investigating the role of maintenance with thalidomide demonstrated a PFS advantage in patients without high risk FISH. However, this did not translate into an OS advantage. Also Thalidomide was poorly tolerated with significant grade 3-4 peripheral neuropathy rates of up to 19%, frequently leading to early discontinuation (Attal et al., 2006; Barlogie et al., 2006; Morgan et al., 2012) and is therefore not used.</p>
<ul style="list-style-type: none"> How does healthcare resource use differ between the technology and current care? 	<p>Current care is observation which usually means 1-3 monthly clinic visits</p>
<ul style="list-style-type: none"> In what clinical setting should the technology be 	<p>Haematology clinics in secondary or tertiary hospitals only</p>

<p>used? (For example, primary or secondary care, specialist clinics.)</p>	
<ul style="list-style-type: none"> What investment is needed to introduce the technology? (For example, for facilities, equipment, or training.) 	<p>It will require more frequent monitoring (4 weekly typically) but there is no requirement for training/education as lenalidomide is an established treatment for patients with myeloma for many years. This monitoring could be done by other healthcare professionals such as pharmacists or nurses other than doctors.</p>
<p>11. Do you expect the technology to provide clinically meaningful benefits compared with current care?</p>	<p>Yes. Lenalidomide maintenance has clear significant benefits for patients in terms of disease control duration, overall survival and quality of life benefits at a time in the disease course when patients are at their most medically well. It is considered the standard of care in EU and USA on the basis of the robust phase 3 trial data and meta analysis</p>
<ul style="list-style-type: none"> Do you expect the technology to increase length of life more than current care? 	<p>Yes</p>
<ul style="list-style-type: none"> Do you expect the technology to increase health-related quality of life more than current care? 	<p>Yes</p>

<p>12. Are there any groups of people for whom the technology would be more or less effective (or appropriate) than the general population?</p>	<p>No cannot say this</p>
<p>The use of the technology</p>	
<p>13. Will the technology be easier or more difficult to use for patients or healthcare professionals than current care? Are there any practical implications for its use (for example, any concomitant treatments needed, additional clinical requirements, factors affecting patient acceptability or ease of use or additional tests or monitoring needed.)</p>	<p>Lenalidomide is an established treatment in the UK so myeloma healthcare professionals are familiar with it.</p> <p>Yes of course there is bound to be 1) increased toxicity compared to doing nothing for a minority of patients 2) more frequent monitoring that will increase the burden on NHS capacity</p>

<p>14. Will any rules (informal or formal) be used to start or stop treatment with the technology? Do these include any additional testing?</p>	<p>Yes these are already well defined in the SPC</p> <p>No additional testing required</p>
<p>15. Do you consider that the use of the technology will result in any substantial health-related benefits that are unlikely to be included in the quality-adjusted life year (QALY) calculation?</p>	<p>Not sure how well a QALY captures the advantage of being reasonably well and disease free for an extra 2-3 years compared to relapsing and requiring further treatment</p>
<p>16. Do you consider the technology to be innovative in its potential to make a significant and substantial impact on health-related benefits and how might it improve the way that current</p>	<p>Yes</p>

need is met?	
<ul style="list-style-type: none"> Is the technology a 'step-change' in the management of the condition? 	Yes, in the setting of a comparator where maintenance is not routinely used
<ul style="list-style-type: none"> Does the use of the technology address any particular unmet need of the patient population? 	Yes – there is an unmet need as the disease is incurable with a median survival of < 6 years
17. How do any side effects or adverse effects of the technology affect the management of the condition and the patient's quality of life?	<p>Some patients will have toxicity with treatment.</p> <p>Main issues will be fatigue, poor concentration, diarrhoea, low blood counts and increase thromboembolic risk. There is also a slight increase in secondary malignancies. All of these side effects have been characterised over 15+ years of use of this drug and are manageable for the majority of patients.</p>
Sources of evidence	
18. Do the clinical trials on the technology reflect current UK clinical practice?	<p>Yes – in fact the largest trial was in the UK -UK Myeloma XI – and recruited nearly 2000 patients</p> <p>Lenalidomide is the only drug currently licensed for maintenance therapy in multiple myeloma (approved by European Medicines Agency and US Food and Drug Administration). Four large randomised control studies (CALGB 100104, GIMEMA, IFM 2005-02 and UK MRC Myeloma XI) have demonstrated a PFS advantage in patients receiving lenalidomide maintenance post ASCT. The UK Myeloma XI study has been the only study powered to detect an overall survival advantage of lenalidomide maintenance post ASCT. Furthermore, a meta-analysis of all published trials of lenalidomide maintenance after ASCT (3179</p>

	patients), demonstrated an OS benefit compared with observation (hazard ratio 0.72 [95% CI 0.56–0.91])(Jackson et al., 2018).
<ul style="list-style-type: none"> If not, how could the results be extrapolated to the UK setting? 	
<ul style="list-style-type: none"> What, in your view, are the most important outcomes, and were they measured in the trials? 	<p>PFS, OS and QoL</p> <p>QoL has been measured but perhaps not in all the trials</p>
<ul style="list-style-type: none"> If surrogate outcome measures were used, do they adequately predict long-term clinical outcomes? 	n/a
<ul style="list-style-type: none"> Are there any adverse effects that were not apparent in clinical trials but have come to light subsequently? 	no
19. Are you aware of any relevant evidence that might not be found by a systematic	No

review of the trial evidence?	
20. Are you aware of any new evidence for the comparator treatment(s) since the publication of NICE technology appraisal guidance [TAXXX]? [delete if there is no NICE guidance for the comparator(s) and renumber subsequent sections]	no
21. How do data on real-world experience compare with the trial data?	Yes it compares with real world data (Jagannath S <i>et al</i> , 2018 -Blood Adv. 2018 Jul 10;2(13):1608-1615.)
Equality	
22a. Are there any potential equality issues that should be taken into account when considering this treatment?	no

<p>22b. Consider whether these issues are different from issues with current care and why.</p>	
<p>Topic-specific questions</p>	
<p>23 [To be added by technical team at scope sign off. Note that topic-specific questions will be added only if the treatment pathway or likely use of the technology remains uncertain after scoping consultation, for example if there were differences in opinion; this is not expected to be required for every appraisal.]</p> <p>if there are none delete highlighted rows and</p>	

renumber below

Key messages

24. In up to 5 bullet points, please summarise the key messages of your submission.

- There is a clear clinical benefit for using lenalidomide maintenance established in at least 4 large randomised trials and meta-analysis and real world experience gained over 10+ years. This benefit is highly significant statistically and amounts to >2 years PFS and a survival benefit
- The drug is well established in UK myeloma practice so will not be expected to lead to any unexpected side effects
- The drug is well established in UK myeloma practice so will not require any additional learning for healthcare professionals
- Lenalidomide maintenance has been an established standard of care treatment in North America and Europe and recommended in international guidelines so the UK is currently lagging behind current gold standard management
- There will be some additional toxicity from the drug and an increased requirement for monitoring more frequently compared with a no maintenance strategy. Financially the drug is expensive so clearly health economic assessment is key in this appraisal.

Thank you for your time.

Please log in to your NICE Docs account to upload your completed submission.

.....

Your privacy

The information that you provide on this form will be used to contact you about the topic above.

Please tick this box if you would like to receive information about other NICE topics.

For more information about how we process your personal data please see our [privacy notice](#).

.....

Patient expert statement

Lenalidomide for the maintenance treatment of multiple myeloma after autologous stem cell transplantation [ID475]

Thank you for agreeing to give us your views on this technology and its possible use in the NHS.

You can provide a unique perspective on conditions and their treatment that is not typically available from other sources.

To help you give your views, please use this questionnaire with our guide for patient submissions.

You do not have to answer every question – they are prompts to guide you. The text boxes will expand as you type.

Information on completing this expert statement

- Please do not embed documents (such as a PDF) in a submission because this may lead to the information being mislaid or make the submission unreadable
- We are committed to meeting the requirements of copyright legislation. If you intend to include **journal articles** in your submission you must have copyright clearance for these articles. We can accept journal articles in NICE Docs.
- Your response should not be longer than 10 pages.

About you

1. Your name

Stephen Billcliffe

<p>2. Are you (please tick all that apply):</p>	<p><input checked="" type="checkbox"/> a patient with the condition? <input type="checkbox"/> a carer of a patient with the condition? <input type="checkbox"/> a patient organisation employee or volunteer? <input type="checkbox"/> other (please specify):</p>
<p>3. Name of your nominating organisation</p>	<p>Myeloma UK</p>
<p>4. Did your nominating organisation submit a submission?</p>	<p><input checked="" type="checkbox"/> yes, they did <input type="checkbox"/> no, they didn't <input type="checkbox"/> I don't know</p>
<p>5. Do you wish to agree with your nominating organisation's submission? (We would encourage you to complete this form even if you agree with your nominating organisation's submission)</p>	<p><input checked="" type="checkbox"/> yes, I agree with it <input type="checkbox"/> no, I disagree with it <input type="checkbox"/> I agree with some of it, but disagree with some of it <input type="checkbox"/> other (they didn't submit one, I don't know if they submitted one etc.)</p>

<p>6. If you wrote the organisation submission and/ or do not have anything to add, tick here. <u>(If you tick this box, the rest of this form will be deleted after submission.)</u></p>	<p><input type="checkbox"/> yes</p>
<p>7. How did you gather the information included in your statement? (please tick all that apply)</p>	<p><input checked="" type="checkbox"/> I have personal experience of the condition</p> <p><input type="checkbox"/> I have personal experience of the technology being appraised</p> <p><input type="checkbox"/> I have other relevant personal experience. Please specify what other experience:</p> <p><input type="checkbox"/> I am drawing on others' experiences. Please specify how this information was gathered:</p>
<p>Living with the condition</p>	
<p>8. What is it like to live with the condition? What do carers experience when caring for someone with the condition?</p>	<p>Knowing that there is no cure for Myeloma is a particular worry. I recall the severe bone pain I experienced when first diagnosed with the disease six years ago and always 'listen' to my body in case symptoms return. I am aware of the cyclical nature of Myeloma – the first line of treatment is likely to be the most effective and long lasting. I am therefore making the most of my years of remission. Rather than 'living with a condition' I prefer to think that I am 'living with a treatment'.</p>

Current treatment of the condition in the NHS	
9. What do patients or carers think of current treatments and care available on the NHS?	I regard myself as fortunate in being accepted to take part in the Myeloma XI Trial – and then randomly sampled to receive the Lenalidomide maintenance treatment, following my stem cell transplant. The alternative option – to ‘wait and see’ – would not have given me such a long period of remission and would have been stressful for myself and my family. When I consider the challenges (and indeed the cost to the NHS) of my initial treatment, the process of preparing for, undertaking and recovering from a stem cell transplant, I think anything that can maximise the benefits of this year-long experience has got to be a good thing.
10. Is there an unmet need for patients with this condition?	An effective ‘first line’ treatment that prolongs remission for newly diagnosed Myeloma patients.
Advantages of the technology	
11. What do patients or carers think are the advantages of the technology?	Extended remission from Myeloma. The lenalidomide maintenance treatment has given me an enhanced quality of life. I have enjoyed my retirement and taken on new pastimes. Family life has been especially beneficial. My wife and I have developed an online bookselling business. We have become used to the ‘new normal’ of life with lenalidomide – not to mention the impact of Covid-19 !
Disadvantages of the technology	
12. What do patients or carers think are the disadvantages of the technology?	I have learnt to cope with the predicted side-effects of lenalidomide. In particular a reduction in my neutrophil count and a susceptibility to infection. I have had to take special care of my diet. Eating out and pre-prepared meals have been off the menu. Other side-effects (such as peripheral neuropathy) have been less of a concern. Taking part in the Myeloma XI Trial has also involved monthly blood tests, regular clinic appointments and keeping to required protocols.

Patient population	
<p>13. Are there any groups of patients who might benefit more or less from the technology than others? If so, please describe them and explain why.</p>	<p>The lenalidomide maintenance treatment would be beneficial for newly diagnosed multiple myeloma patients who were eligible for an autologous stem cell transplant. The potential for a longer period of remission would enhance the quality of life for patients and their families. I also believe that this treatment would give the NHS a significant return for the investment made by clinicians and Trusts in extending the current first line treatment options for their myeloma patients.</p>
Equality	
<p>14. Are there any potential equality issues that should be taken into account when considering this condition and the technology?</p>	<p>I was 64 years old when first diagnosed with multiple myeloma. I would like to think that the age of the patient should not be a consideration when deciding whether or not to offer the option of a stem cell transplant and the lenalidomide maintenance treatment. I have continued to be economically active into my retirement and have made a positive contribution to my family and the community in which I live.</p>
Other issues	
<p>15. Are there any other issues that you would like the committee to consider?</p>	<p>I have been very grateful for the help and support of the Myeloma XI Trial team at the Royal Berkshire Hospital during the past five years and the expert care and knowledge of haematology clinicians in Reading and Oxford. Advice and guidance from members of my local Myeloma Support Group and Myeloma UK has also been invaluable during my journey. I hope that my experiences and input to this appraisal will help the Committee reach a positive conclusion, to enable a wider use of maintenance lenalidomide as a successful treatment for other myeloma patients.</p>

Key messages

16. In up to 5 bullet points, please summarise the key messages of your statement:

- The lenalidomide maintenance treatment has so far given me five years of remission from multiple myeloma
- The treatment has improved my overall survival time
- The quality of life for me and my family has been significantly enhanced since I was first diagnosed with the condition
- I have made good use of my retirement years and remained economically active
- I am pleased to have taken part in the Myeloma XI Trial and hope that my experiences will help future myeloma patients

Thank you for your time.

Please log in to your NICE Docs account to upload your completed statement, declaration of interest form and consent form.

.....

Your privacy

The information that you provide on this form will be used to contact you about the topic above.

Please tick this box if you would like to receive information about other NICE topics.

For more information about how we process your personal data please see our [privacy notice](#).

.....

Patient expert statement

Lenalidomide for the maintenance treatment of multiple myeloma after autologous stem cell transplantation [ID475]

Lenalidomide for the maintenance treatment of newly diagnosed multiple myeloma after autologous stem cell transplantation [ID475]

A Single Technology Appraisal

1

Produced by

Peninsula Technology Assessment Group (PenTAG)
University of Exeter Medical School
South Cloisters
St Luke's Campus
Heavitree Road
Exeter
EX1 2LU

Authors

Caroline Farmer¹
Emma Knowles²
Helen Coelho¹
Justin Matthews¹
Sophie Robinson¹
Naomi Shaw¹
Claudius Rudin³
Jenny Bird⁴
Simone Critchlow²
Louise Crathorne¹
G.J. Melendez-Torres¹

¹ Peninsula Technology Assessment Group (PenTAG), University of Exeter Medical School, Exeter

² Delta Hat Ltd, Nottingham UK

³ Dorset County Hospital, UK

⁴ University Hospitals Bristol NHS Foundation Trust, UK

Correspondence to

Caroline Farmer
3.09 South Cloisters, St Luke's Campus, Heavitree Road, Exeter, EX1 2LU; C.Farmer@exeter.ac.uk

Date completed	28/04/2020
Source of funding	This report was commissioned by the NIHR Systematic Reviews Programme as project number 11/05/01.
Declared competing interests of the authors	The authors listed declared no competing interests.
Copyright	©2020 PenTAG, University of Exeter Copyright is retained by Celgene for tables and figures copied and/or adapted from the CS and other submitted company documents.
Acknowledgments	The authors acknowledge the administrative support provided by Mrs Sue Whiffin and Ms Jenny Lowe (both PenTAG).
Rider on responsibility for document	The views expressed in this report are those of the authors and not necessarily those of the NIHR HTA Programme. Any errors are the responsibility of the authors.
This report should be referenced as follows	Farmer, Knowles, Coelho, Matthews, Robinson, Shaw, Critchlow, Rudin, Bird, Crathorne, Melendez-Torres. Lenalidomide for the maintenance treatment of newly diagnosed multiple myeloma after autologous stem cell transplantation [ID475]: A Single Technology Appraisal. Peninsula Technology Assessment Group (PenTAG), 2020.

1

Author Contributions:

Caroline Farmer	Project lead, critical appraisal of the company submission, writing and editorial input
Emma Knowles	Critical appraisal of the economic evidence and economic analysis submitted by the company, conducted additional economic analysis and drafted the economic sections of the report
Helen Coelho	Critical appraisal of the clinical effectiveness evidence
Justin Matthews	Critical appraisal of the statistical/clinical evidence
Sophie Robinson	Critical appraisal of the literature search strategies
Naomi Shaw	Critical appraisal of the literature search strategies, editorial input
Simone Critchlow	Critical appraisal of the cost-effectiveness evidence and review of the draft report
Claudius Rudin	Clinical advice and review of draft report
Jenny Bird	Clinical advice and review of draft report
Louise Crathorne	Critical appraisal of the company submission, writing and editorial input, and co-supervised the final report
G.J. Melendez-Torres	Critical appraisal of the company submission, writing and editorial input, and co-supervised the final report. Guarantor of the report.

2

3

1 Table of Contents

2	Abbreviations	7
3	1. Executive summary	9
4	1.1. Critique of the decision problem in the company’s submission	9
5	1.2. Summary of the key issues in the clinical effectiveness evidence	9
6	1.3. Summary of the key issues in the cost effectiveness evidence	10
7	1.4. Summary of ERG’s preferred assumptions and resulting ICER	11
8	1.5. Summary of exploratory and sensitivity analyses undertaken by the ERG	12
9	2. Introduction and Background	13
10	2.1. Introduction	13
11	2.2. Critique of company’s definition of decision problem	14
12	3. Clinical Effectiveness	17
13	3.1. Critique of the methods of review	17
14	3.2. Critique of trials of the technology of interest, the company’s analysis and interpretation	19
15	3.2.1. Study design and relevance to decision problem	20
16	3.2.2. Baseline characteristics	25
17	3.2.3. Clinical effectiveness results	25
18	3.2.4. Adverse effects (AEs, SAEs and causes of death)	28
19	3.2.5. Quality assessment of the Trials of the Technology of Interest	30
20	3.3. Critique of additional trials identified in the systematic review	33
21	3.4. Critique of the indirect comparison and/or multiple treatment comparison	33
22	3.5. Additional work on clinical effectiveness undertaken by the ERG	33
23	3.5.1. GIMEMA	33
24	3.5.2. CALGB 100104	35
25	3.5.3. Comparative Quality Assessment of GIMEMA, CALGB, and Myeloma XI	39
26	3.6. Conclusions of the clinical effectiveness section	42
27	4. Cost-effectiveness	44
28	4.1. ERG comment on company’s review of health economic evidence	44
29	4.1.1. Cost-effectiveness evidence	44
30	4.1.2. Health-related quality of life and utilities	45
31	4.1.3. Healthcare resource use and costs	48
32	4.2. Summary and critique of company’s submitted economic evaluation by the ERG	49
33	4.2.1. NICE reference case checklist	49
34		
35		
36		

1	4.2.2.	Model structure	50
2	4.2.3.	Population	54
3	4.2.4.	Interventions and comparators	54
4	4.2.5.	Perspective, time horizon and discounting	55
5	4.2.6.	Treatment effectiveness and extrapolation	55
6	4.2.7.	Health-related quality of life	68
7	4.2.8.	Resources and costs	70
8	5.	Cost-effectiveness results	83
9	5.1.	Company's cost-effectiveness results	84
10	5.1.1.	Base case results	84
11	5.2.	Company's sensitivity analyses	85
12	5.2.1.	One-way sensitivity analysis	85
13	5.2.2.	Probabilistic sensitivity analysis	86
14	5.2.3.	Scenario analyses	88
15	5.3.	Model validation and face validity check	88
16	6.	Evidence Review Group's additional analyses	90
17	6.1.	Exploratory and sensitivity analyses undertaken by the ERG	90
18	6.1.1.	Estimation of overall survival	90
19	6.1.2.	Subsequent therapies	91
20	6.1.3.	Miscellaneous	91
21	6.2.	Impact on the ICER of additional clinical and economic analyses undertaken by the ERG	92
22	6.3.	ERG's preferred assumptions	98
23	6.4.	Conclusions of the cost-effectiveness section	101
24	7.	End of life	104
25	References		105
26			
27			

1 List of tables

2	Table 1: ICER resulting from ERG's preferred assumptions (including PAS)	11
3	Table 2: Exploratory analyses undertaken by the ERG (inclusive of PAS)	12
4	Table 3: Summary of decision problem	15
5	Table 4: Summary of ERG's critique of the methods implemented by the company to	
6	identify evidence relevant to the decision problem	18
7	Table 5: Second-progression-free survival in decision problem cohort	27
8	Table 6: Causes of death	29
9	Table 7: Company and ERG Quality Appraisal of Myeloma XI	31
10	Table 8: GIMEMA Clinical Efficacy Data; and in Comparison to Myeloma XI	35
11	Table 9: CALGB Clinical Efficacy Data; Comparison to Myeloma XI	37
12	Table 10: Adverse events in CALGB 100104	39
13	Table 11: Quality Appraisal of GIMEMA, CALBG 100104, and Comparison with	
14	Myeloma XI	40
15	Table 12. Summary of ERG's critique of the methods implemented by the company to	
16	identify health economic evidence: cost-effectiveness	44
17	Table 13. Summary of ERG's critique of the methods implemented by the company to	
18	identify health economic evidence: health-related quality of life	46
19	Table 14. Summary of ERG's critique of the methods implemented by the company to	
20	identify health economic evidence: healthcare resource use and costs	48
21	Table 15: NICE reference case checklist	49
22	Table 16: Utility values (not adjusted for age or adverse events) used in model	69
23	Table 17: List price of lenalidomide	71
24	Table 18: Comparison of company's and ERG's preferred subsequent therapy settings	79
25	Table 19 Company base case results	84
26	Table 20: Additional sensitivity analyses (centered on company base case)	92
27	Table 21: ERG's preferred model assumptions (company PAS settings)	98
28	Table 22: ERG's preferred model assumptions (list price for all drugs)	98
29	Table 23: Comparison of company and ERG base-case results	99
30	Table 24: Comparison of company and ERG base-case results (list prices for all)	99
31	Table 25: Comparison of company and ERG scenario analysis results	100

1 List of Figures

2	Figure 1: Company model structure	51
3	Figure 2: Derivation of health state occupancy	51
4	Figure 3: Company base-case projections of overall survival	57
5	Figure 4: Comparison of independent log-logistic and Weibull projections of overall	
6	survival	58
7	Figure 5: Implied hazard ratio in company's base-case analysis	59
8	Figure 6: Log-cumulative hazard plot (OS from CALGB 100104)	62
9	Figure 7: Q-Q plot (OS from CALGB 100104)	63
10	Figure 8: ERG's preferred extrapolation of OS	64
11	Figure 9: Comparison of exponential and log-logistic models for PFS	66
12	Figure 10: ERG's preferred extrapolation of PFS	67
13	Figure 11: ERG's preferred extrapolation of TTD	74
14	Figure 12: ERG analysis: Assumed duration of treatment effect versus ICER	94
15	Figure 13: ERG analysis: subsequent therapy cost savings versus ICER	95
16	Figure 14: ERG analysis: Heat map of duration of treatment effect versus subsequent	
17	therapy cost savings	97
18		

1 Abbreviations

AE	adverse events
AF	acceleration factor
AFT	accelerated failure time
AIC	Akaike information criterion
ASCT	autologous stem cell transplant
BIC	Bayesian information criterion
BNF	British National Formulary
BOR	bortezomib
BSA	body surface area
CALGB	Cancer and Leukemia Group B
CAR	carfilzomib
CD	carfilzomib + dexamethasone
CDF	Cancer Drugs Fund
CEAC	cost-effectiveness acceptability curve
CI	confidence interval
CRD	cyclophosphamide + lenalidomide + dexamethasone
CRUK	Cancer Research UK
CS	Company Submission
CTD	cyclophosphamide, thalidomide and dexamethasone
DARA	daratumumab
DARA-VD	daratumumab + bortezomib + dexamethasone
DEX	dexamethasone
DSU	Decision Support Unit
ECOG	Eastern Cooperative Oncology Group
EMA	European Medicines Agency
eMIT	electronic market information tool
ERG	Evidence Review Group
GIMEMA	Gruppo Italiano Malattie EMatologiche dell'Adulto
HDT	high-dose treatment
HRQoL	health-related quality of life
HR	hazard ratio
ICER	incremental cost-effectiveness ratio
IFM 2005-02	Intergroupe Francophone du Myelome 2005-02 trial
IMiD	immunomodulatory imide drug
IQR	interquartile reange
ISS	international staging system
ITT	intention to treat
KCRD	carfilzomib + cyclophosphamide + lenalidomide + dexamethasone
LYs	life years

MM	multiple myeloma
MRU	medical resource use
MSM	multi-state model
NA	not applicable
NICE	National Institute for Health and Care Excellence
NR	not reported
OS	overall survival
OWSA	one-way sensitivity analysis
PAD	bortezomib, dexamethasone and doxorubicin
PartSA	partitioned survival analysis
PAS	patient access scheme
PFS	progression free survival
PH	proportional hazards
PSA	probabilistic sensitivity analysis
PSM	progressive disease state membership
QALYs	quality adjusted life years
RCT	randomised controlled trial
RDI	relative dose intensity
RPSFTM	rank preserving structural failure time model
SAEs	serious adverse events
SCT	stem cell transplantation
SLR	systematic literature review
SmPC	Summary of Product Characteristics
t	time
TFI	treatment free interval
THAL	thalidomide
TSD	Technical Support Document
TTD	time to discontinuation
TTP	time to progression
VCD	bortezomib and dexamethasone with or without cyclophosphamide
VTD	bortezomib and dexamethasone with or without thalidomide

1. EXECUTIVE SUMMARY

1.1. Critique of the decision problem in the company's submission

Multiple myeloma (MM) is a form of cancer that originates in the plasma cells of the bone marrow. MM is incurable, with treatment primarily oriented towards delaying disease progression. Lenalidomide is an immunomodulatory imide drug taken orally. While currently used for a range of indications in MM, this appraisal concerns the specific positioning of lenalidomide following high-dose chemotherapy and autologous stem cell transplant. Treatment for MM in patients who are eligible for transplant consists of an induction phase followed by chemotherapy and transplant. The current standard of care after transplant is observation, with a range of treatment options available after first and subsequent progression. Thus, the positioning of lenalidomide in this appraisal is as an alternative to observation after transplant but before first progression. The ERG regarded that the Company Submission (CS) appropriately described the disease, its pathophysiology, and its treatment, and the proposed positioning of lenalidomide for this appraisal.

The ERG considered that the company's definition of the decision problem generally matched the NICE scope. The company did not believe that any aspect of their decision problem was different from the scope. However, the ERG observed that while the SmPC for lenalidomide describes a dosing schedule of 10 mg with potential escalation to 15 mg, administered in 28 day cycles, the company suggests that a dosing schedule of 10 mg without escalation and administered for 21 of 28 days is expected to be representative of clinical practice. Thus, the dosing used in this appraisal is at variance with the SmPC. Clinical advice received by the ERG considered that this was appropriate. Data corresponding to scoped outcomes, including overall survival, progression-free survival, time to relapse or progression, and adverse effects of treatment were provided either in the CS or as part of clarification. Health-related quality of life data were not available from the relevant trials.

1.2. Summary of the key issues in the clinical effectiveness evidence

The clinical effectiveness evidence provided by the company primarily related to a subgroup analysis from Myeloma XI, a large, multicentre randomised controlled trial (RCT) of treatments for MM with multiple stages of randomisation and several pathways. The evidence presented, which was described as the 'decision problem cohort', related to a post hoc subgroup analysis of patients randomised either to lenalidomide 10 mg for 21 of 28 days or observation post-

1 transplant. Thus, patients included in this analysis were already randomised to an induction
2 treatment; and then those with unsatisfactory response were randomised to intensification or no
3 intensification therapy. All patients received transplant upon satisfactory response to induction;
4 and were then re-randomised to lenalidomide or observation. Reporting of data from Myeloma
5 XI was patchy, and due to trial design adverse events data were not available for patients
6 randomised to observation. The CS did not fully report the treatment pathway received by the
7 target patient population in the Myeloma XI trial. The ERG also identified several issues with
8 generalisability of the trial to the current UK context. The induction treatments used in the trial
9 no longer reflect current UK practice, as other, more effective regimens are now used
10 frequently. However, the ERG considered that the data presented were still relevant to UK
11 practice.

12 The ERG considered that the evidence base was of high quality and suggests that lenalidomide
13 maintenance therapy may reduce the risk of mortality and disease progression in patients with
14 MM following ASCT, as compared to observation or placebo. However, while the ERG regarded
15 that the methods used to locate evidence were appropriate, the CS arbitrarily excluded findings
16 from two potentially relevant RCTs, CALGB 100104 and GIMEMA. The ERG extracted and
17 presented information for relevant subgroups from these trials.

18 **1.3. Summary of the key issues in the cost effectiveness evidence**

19 The ERG identified a range of inconsistencies in the systematic reviews used to identify prior
20 relevant economic evaluations, health-related quality of life (HRQoL) and healthcare resource
21 use and costs. In particular, the systematic review of HRQoL included seemingly arbitrary
22 criteria and selection processes for the inclusion of studies.

23 The company's base case generated an ICER of [REDACTED] per QALY gained, inclusive of PAS. In
24 sum, the ERG believes that the company's model does not provide a strong basis for decision-
25 making, due to substantial structural and parameter uncertainty in the model. The company
26 adopted a partitioned survival analysis model structure, with three mutually exclusive health
27 states: pre-progression, progressive disease and death. While this structure is intuitively
28 appealing, it is subject to a number of important limitations that preclude an appropriate
29 representation of the cost-effectiveness of lenalidomide. Most notably, the estimation of costs
30 and effects related to treatments given after maintenance (or observation) is highly uncertain,
31 though this is a key driver of model results. The proportions of treatment regimens used in post-
32 progression treatment, which was assumed to include two additional lines of therapy for each

1 patient, drew on a reweighted analysis of a clinician survey once ineligible treatment strategies
 2 (such as those currently funded by the Cancer Drugs Fund) were excluded. In addition,
 3 subsequent transplants were not included in the model despite their relevance as a treatment
 4 option after durable first response. The decision problem cohort that informed analysis in this
 5 appraisal included relatively immature data for overall survival, despite the signal importance of
 6 this outcome in determining cost-effectiveness. Survival was also not related to the costs and
 7 benefits of post-progression therapies. Finally, the impact of dose adjustments for lenalidomide
 8 remains uncertain, and differences between treatment strategies in medical resource use over
 9 time are difficult to reflect in the model structure.

10 1.4. Summary of ERG’s preferred assumptions and resulting ICER

11 Based on its own analysis, the ERG preferred several assumptions at variance with the
 12 company’s submitted evidence:

- 13 • a joint log-logistic distribution for overall survival,
- 14 • a joint Weibull distribution for progression-free survival,
- 15 • increased relative dose intensity for lenalidomide maintenance,
- 16 • medical resource use costs post-relapse to be equal to those pre-relapse based on clinical
 17 advice,
- 18 • different estimates for post-progression treatment based on clinical advice, and
- 19 • alternative costs for several treatment regimens, including removal of an assumed PAS for
 20 bortezomib.

21 **Table 1: ICER resulting from ERG’s preferred assumptions (including PAS)**

	Total costs	Total LYs	Total QALYs	Δ costs	Δ LYs	Δ QALYs	ICER £/QALY
Observation	■	■	■				
Lenalidomide	■	■	■	■	■	■	■

22 Key: ICER, incremental cost effectiveness ratio; QALYs, quality adjusted life years

23

1 **1.5. Summary of exploratory and sensitivity analyses undertaken by the ERG**

2 The ERG undertook a range of exploratory and sensitivity analyses focusing on alternative
 3 costing assumptions, parametric survival curve fits, and relative dose intensity. These are
 4 presented below using the company’s base case as a starting point.

5 **Table 2: Exploratory analyses undertaken by the ERG (inclusive of PAS)**

Scenario	ICER £/QALY
All subsequent therapy costs removed	■■■■
Delay impact of age adjustment on utility by 5 years	■■■■
Include terminal care costs of £7,157	■■■■
Use CALGB 100104 curves + costing	■■■■
Use Weibull for TTD	■■■■
Use Gompertz for TTD	■■■■
Use (joint) Weibull for PFS	■■■■
Use (joint) log-logistic for PFS	■■■■
Use independent Weibull (Obs) and independent Weibull (Len) for OS	■■■■
Use independent log-logistic (Obs) and independent log-logistic (Len) for OS	■■■■
Use independent Weibull (Obs) and independent log-logistic (Len) for OS	■■■■
Use independent log-logistic (Obs) and independent Weibull (Len) for OS*	■■■■
Use dependent Weibull for OS	■■■■
Use dependent log-logistic for OS	■■■■
Set RDI for all treatments to 100%	■■■■
Set RDI for lenalidomide maintenance only to 100%	■■■■

6 Key: ERG, Evidence Review Group; ICER, incremental cost effectiveness ratio; QALYs, quality adjusted life years

1 2. INTRODUCTION AND BACKGROUND

2 2.1. Introduction

3 Multiple myeloma (MM) is a form of cancer that originates in the plasma cells of the bone
4 marrow. MM is incurable, with treatment primarily oriented towards delaying disease
5 progression. Data from Cancer Research UK¹ suggests an incidence of 5,034 UK cases in
6 2017. MM is more common in men and has a median age of onset of 73 years. The Evidence
7 Review Group (ERG) regarded that the Company Submission (CS) had an acceptable
8 description of the disease; its pathophysiology, natural course and epidemiology; and the
9 current treatment options available.

10 Current NICE guidance on management of myeloma (NG35)² specifies several stages to
11 treatment of newly diagnosed MM. These stages are broadly organised as induction; where
12 necessary, intensification; high-dose therapy (HDT) and autologous stem cell transplant
13 (ASCT); and subsequent treatment after first progression. Transplant eligibility is decided on the
14 basis of patient frailty and comorbidities, and thus transplant recipients tend to be younger and
15 fitter. The current standard of care after transplant is observation, with a range of treatment
16 options available after first and subsequent progression.

17 Lenalidomide is an immunomodulatory imide drug (IMiD) taken orally. It belongs to the same
18 class of drugs as thalidomide and pomalidomide, which are also used for the treatment of MM.
19 Lenalidomide is currently used for a range of indications in MM, including for those who are not
20 eligible for transplant, and for other haematological cancers. The purpose of this appraisal is to
21 consider lenalidomide for the treatment of newly diagnosed MM in patients who have received
22 ASCT, prior to first progression. This report summarises the ERG's critique of the Company's
23 Submission (CS), which contains evidence for the clinical and cost effectiveness of lenalidomide
24 in the target population.

25

2.2. Critique of company's definition of decision problem

The ERG considered that the company's definition of the decision problem generally matched the decision problem in the NICE scope. The company did not provide rationale where the decision problem addressed in the CS varied from the NICE scope. The ERG considered that this was because the company's decision problem fell within the NICE scope (i.e. no additions or alterations were made; labelled as not applicable in CS Table 1, page 10). For clarity, the ERG has provided comment on any differences (e.g. where the company's decision problem was narrower than the NICE scope) and other important considerations relevant to the company's decision problem in Table 3.

Table 3: Summary of decision problem

	Final scope issued by NICE	Decision problem addressed in the company submission	ERG comment
Population	People with newly diagnosed MM who have had ASCT	Adults with newly diagnosed MM who have had ASCT	The ERG believed the populations were appropriately matched.
Intervention	Lenalidomide	Lenalidomide as monotherapy for maintenance treatment	The ERG regarded that the company's intended positioning, including as compared to current standard of care, was appropriate and well described. The ERG noted that the company's statement matches the marketing authorisation for lenalidomide. However, the ERG also noted that the posology used varies from the SmPC. The company's rationale for this was that the posology used is a better match to UK clinical practice.
Comparator(s)	Established clinical management without lenalidomide maintenance therapy (including monitoring and follow up)	Observation	The ERG was satisfied that the comparators were similar between the NICE scope and the company's decision problem.
Outcomes	The outcome measures to be considered include: <ul style="list-style-type: none"> • overall survival • progression-free survival • time to relapse or progression • adverse effects of treatment • health-related quality of life 	The outcome measures to be considered include: <ul style="list-style-type: none"> • overall survival • progression-free survival • adverse effects of treatment • health-related quality of life Time to progression was supplied on clarification.	The ERG noted that while progression-free survival was presented by the company, time to relapse or progression <i>not</i> as a composite outcome was omitted, but was subsequently provided in clarification. Adverse effects data were not provided for patients in the decision problem cohort receiving observation alone.

			Health-related quality of life data were also not collected as part of the submitted trial, Myeloma XI.
Economic analysis	The reference case stipulates that the cost effectiveness of treatments should be expressed in terms of incremental cost per quality-adjusted life year. The reference case stipulates that the time horizon for estimating clinical and cost effectiveness should be sufficiently long to reflect any differences in costs or outcomes between the technologies being compared. Costs will be considered from an NHS and Personal Social Services perspective. The availability of any commercial arrangements for the interventions, comparator and subsequent treatment technologies will be taken into account.	The company noted that they adhered to the appropriate reference case.	The ERG agreed that the reference case was as stated.
Subgroups	None	None	N/A
Special considerations including issues related to equity or equality	Guidance will only be issued in accordance with the marketing authorisation. Where the wording of the therapeutic indication does not include specific treatment combinations, guidance will be issued only in the context of the evidence that has underpinned the marketing authorisation granted by the regulator.	N/A	N/A

Key: ASCT, autologous stem cell transplantation; ERG, Evidence Review Group; MM, multiple myeloma; NICE, National Institute for Health and Care Excellence; SmPC, Summary of Product Characteristics

1 3. CLINICAL EFFECTIVENESS

2 The sections below discuss the evidence submitted by the company in support of the clinical
3 effectiveness of lenalidomide as a maintenance therapy for the maintenance treatment of newly
4 diagnosed MM after ASCT. The ERG has critiqued the details provided on:

- 5 • Methods implemented to identify, screen and data extract relevant evidence;
- 6 • Clinical efficacy of lenalidomide;
- 7 • Safety profile of lenalidomide;
- 8 • Assessment of comparative clinical effectiveness of lenalidomide against relevant
9 comparators.

10 The ERG provide a summary critique of the main clinical efficacy and safety outcomes,
11 presented in the CS. Further to this, a detailed description of an aspect of the CS is provided
12 only when the ERG disagrees with the company's assessment or proposal, or where the ERG
13 has identified a potential area of concern that the ERG considers necessary to highlight for the
14 Committee.

15 Broadly speaking, the ERG considered that methodology and outcome data relevant to the
16 decision problem were patchily reported in the CS. Frequently, information and data for
17 subgroups of patients not relevant to the NICE problem (e.g. the full Myeloma XI intention-to-
18 treat [ITT] population) were presented, which made it difficult to initially identify where gaps
19 existed in the CS. Where gaps were identified, the ERG were unable to identify the information
20 from elsewhere (e.g. from trial publications or the clinical study report) as the evidence
21 presented in the CS were taken from an unplanned analysis of data from a larger trial
22 (Clarification A16), and not published elsewhere.

23 3.1. Critique of the methods of review

24 The company undertook a systematic review to identify relevant publications on the efficacy and
25 safety of lenalidomide monotherapy as maintenance therapy after ASCT in patients with newly
26 diagnosed MM. Studies of maintenance with lenalidomide monotherapy were considered when
27 given for both days 1-21 of a 28-day cycle and for days 1-28 of a 28-day cycle, as per the
28 lenalidomide marketing authorisation. Four randomised controlled trials (CALGB 100104,^{3,4}
29 GIMEMA,⁵ IFM 2005-02⁶ and Myeloma XI⁷ were identified that reported clinical outcomes in

1 patients with newly diagnosed MM who received lenalidomide maintenance therapy following
 2 ASCT. The company considered that only the Myeloma XI⁷ study was relevant to the decision
 3 problem as it comprised a large UK population and is the only trial to follow UK-based clinical
 4 practice, unlike the CALGB 100104,^{3,4} GIMEMA,⁵ and IFM 2005-02⁶ studies. The CS focused
 5 on the cohort of patients enrolled in Myeloma XI⁷ who were randomised to receive post-ASCT
 6 maintenance with lenalidomide 10 mg only. The identified evidence is critiqued in Section 3.2.

7 The ERG regarded that on the whole, the methods used to locate studies in the systematic
 8 review were reasonable and appropriate, and were likely to have identified the relevant trials.
 9 However, the ERG disagreed in respect of the criteria used to exclude the three other trials
 10 identified by the company's systematic review, further noting that more clinical evidence could
 11 be considered potentially relevant for decision-making, and observed that key aspects of the
 12 review methods used were underreported. This undermines confidence in the accuracy of the
 13 data presented. A summary of the ERG's critique of the methods implemented by the company
 14 to identify evidence relevant to the decision problem is presented in Table 4.

15 **Table 4: Summary of ERG's critique of the methods implemented by the company to**
 16 **identify evidence relevant to the decision problem**

Systematic review step	Section of CS in which methods are reported	ERG assessment of robustness of methods
Searches	Appendix D, Section D.1.1	The ERG was broadly satisfied that the clinical effectiveness searches identified the most relevant evidence for lenalidomide in the population of interest. The ERG noted the following limitations: use of RCT filter other than Cochrane; no comparator search (although the ERG noted no relevant comparators at this stage of the pathway); no adverse event search
Inclusion criteria	Appendix D, Section D.1.2.1 Table 7	The criteria restricted included trials to populations and treatment pathways as defined in the NICE decision problem. Dosing of lenalidomide was included in both 21 days of a 28 day cycle and in 28 days of a 28 day cycle. Notably, studies were excluded if patients received consolidation therapy after ASCT, or if post-ASCT treatment did not include a lenalidomide monotherapy arm. The ERG considered the searches were appropriate for locating the relevant evidence, but noted that a subsequent set of criteria, which the company stated were designed to match the included trials to UK clinical practice, were subsequently applied. These criteria were not formally presented. The impacts of this on included evidence are considered in Section 4.2.1.
Screening	Appendix D, Section D1.2.1	Appropriate. All abstracts were dual screened versus pre-defined eligibility criteria with discrepancies resolved

		with a third party. Potential full text articles were retrieved and screened in the same way.
Data extraction	NR*	The ERG could not locate details of how data extraction was undertaken. While this omission is possibly less consequential given that interim data from only one trial were presented, the ERG considered that this undermined confidence in the accuracy of the characteristics of the key trials
Tool for quality assessment of included study or studies	Appendix D, Section D.1.5	Quality assessment was undertaken using the Cochrane Risk of Bias tool, v2. The ERG considered that this was an appropriate tool; however, whether assessment was undertaken in duplicate was not described, nor were reasons provided to support the risk of bias judgments. This was an important omission in reporting. The ERG independently replicated the quality assessment and provides its findings in Section 4.3 below
Evidence synthesis	Document B, Section B.2.8 and Section B.2.9	The company only identified one trial that they regarded as meaningful to the decision problem, as such a meta-analysis was not presented.

1 Key: CS, Company submission; ERG, Evidence Review Group; NR, not reported

2 Note: * No specific data extraction template or detail was provided. It appeared that data were extracted straight to
3 tables in the report e.g. study characteristics, baseline characteristics and results

4

5 3.2. Critique of trials of the technology of interest, the company's analysis and 6 interpretation

7 The company's clinical effectiveness SLR identified four trials that evaluated lenalidomide
8 maintenance therapy for the target population; however only one of these (Myeloma XI⁷) was
9 ultimately included. As noted in Section 4.1, an unspecified set of additional criteria was used to
10 exclude the other three trials. The company note that the treatment pathways used in the trials
11 vary from current UK clinical practice, though the rationale for exclusion of some trials seemed
12 irrelevant; for example, the company noted that only Myeloma XI⁷ was powered to detect
13 differences on overall survival, but this power calculation did not relate to the specific subgroup
14 analysis presented in the CS. The company also excluded the Gruppo Italiano Malattie
15 EMatologiche dell'Adulto (GIMEMA)⁵ trial because the study population included both ASCT-
16 eligible and ASCT-ineligible patients; however the ERG identified relevant data in the subgroup
17 of ASCT-eligible patients. Furthermore, while the ERG acknowledged that the treatment
18 pathway used in the Cancer and Leukaemia Group B (CALGB) 100104 trial^{3,4} varies from UK
19 clinical practice, the company stated that they considered data from CALGB 100104 to be
20 sufficiently comparable to Myeloma XI⁷ (CS p.68) in order to use it to validate extrapolated data
21 in their economic model. While the ERG noted that there are significant limitations in the
22 conduct and generalisability of the CALGB 100104^{3,4} and GIMEMA⁵ trials, the ERG

1 nevertheless considered that these trials met the company's inclusion criteria for the SLR, and
2 should have been included in the CS. The ERG provide a summary of the methods, clinical
3 efficacy data, and quality assessment from both of these trials in Section 3.5. The ERG agreed
4 with the company that data from the Intergroupe Francophone du Myelome (IFM) 2005-02⁶ trial
5 has limited applicability to UK practice, and therefore data from this trial is not presented.

6 **3.2.1. Study design and relevance to decision problem**

7 The trial included from the company's SLR, Myeloma XI,⁷ is a Phase III, open label parallel RCT
8 evaluating lenalidomide maintenance treatment in patients in the UK with MM. The trial design
9 incorporates a complex treatment pathway, with multiple levels of randomisation and planned
10 comparisons. The data reported in the CS are from an unplanned subgroup comparison of
11 lenalidomide maintenance and observation in patients who met the NICE decision problem
12 criteria. While randomisation is retained for this subgroup, there are limitations to using data
13 from an unplanned subgroup (such as the lack of planned sample calculations, and whether
14 data collected are suitable to the reported comparison).

15 The population, intervention, and outcomes in the Myeloma XI⁷ subgroup comparison presented
16 were broadly consistent with the NICE decision problem. However, outcomes reported in the CS
17 did not include health-related quality of life (HRQoL), and adverse event (AE) data were only
18 reported for the lenalidomide maintenance arm due to the trial design. Furthermore, median
19 times to event data were not available for all clinical outcomes, as median event rate had not
20 been reached in both arms.

21 The ERG and NICE discussed the discrepancy between the dose of lenalidomide used in
22 Myeloma XI⁷ and the EMA licence (pre-clarification meeting teleconference, 11/03/2020). For
23 the purposes of this appraisal, and following clinical advice, the ERG considered that the dose
24 of lenalidomide used in Myeloma XI⁷ is consistent with UK clinical practice and consistent with
25 the NICE decision problem.

26 **3.2.1.1. Randomisation stages and protocol amendments**

27 The Myeloma XI⁷ trial involved two randomisation stages in addition to the randomisation of
28 patients to lenalidomide maintenance and observation, which is the target for this appraisal.
29 Randomisation was carried out appropriately, and maintained for the target population, and
30 previous randomisation stages were not considered by the ERG to undermine the
31 generalisability of the trial population to UK practice. The trial was subject to multiple protocol

1 amendments; the subgroup data reported in the CS were those treated under protocol version 5
2 and 6, though the ERG did not consider amendments in protocol 6 to affect this subgroup or
3 comparison. The dose of lenalidomide used in the target population for this appraisal was
4 informed by interim trial results under protocol version 1 of the Myeloma XI⁷ trial, where patients
5 receiving 25mg lenalidomide experienced levels of toxicity that the company deemed
6 unacceptable (CS p. 34). The ERG noted that protocol amendments and the use of unplanned
7 comparisons in research may carry a higher risk of bias (see Section 3.2.5); however the ERG
8 did not identify any specific cause for concern from the trial design.

9 3.2.1.2. Treatment pathways in Myeloma XI

10 The CS did not fully report the treatment pathway received by the target patient population in
11 the Myeloma XI trial.⁷ The specific therapies received by patients during the trial were requested
12 by the ERG at clarification (Clarification A13 overall and by arm), and while the company
13 subsequently provided these for the overall cohort, no breakdown by arm was provided. This
14 means that the ERG were only able to consider the relevance of the treatment pathway for UK
15 clinical practice, and were not able to judge whether differences in treatment pathway between
16 trial arms may have affected outcome assessment.

17 For clarity, incorporating the information from the CS and the clarification process, the ERG
18 summarise available information on the treatment pathway received by patients below.

19 Initially, treating clinicians considered whether patients were eligible for ASCT on the basis of
20 Eastern Cooperative Oncology Group (ECOG) performance status, clinical judgement, and
21 patient preference (CS p. 33). However in general, fitter patients aged 60 or younger received
22 ASCT, while those aged 70 years or older did not receive ASCT.⁷ After this, patients were
23 treated according to the following steps:

- 24 1. All patients received a minimum of four cycles of randomised induction therapy with CTD
25 (30.7%), cyclophosphamide + lenalidomide + dexamethasone (CRD) (35.3%), or
26 carfilzomib + cyclophosphamide + lenalidomide + dexamethasone (KCRD) (34.0%)
27 (Clarification A13).
- 28 2. Patients with a suboptimal response to induction (52.3%) were randomised to receive
29 intensification with bortezomib + dexamethasone + cyclophosphamide (VCD) or
30 observation (Clarification A13).
- 31 3. All patients in the decision problem cohort received HDT with melphalan and ASCT (CS
32 p. 33).

- 1 4. After 100 days, patients who exhibited a complete or very good partial response (80.5%)
- 2 or a partial or minimal response (16.9%) were randomised to either lenalidomide
- 3 maintenance or observation (Clarification A13). An additional 2.4% of people in the
- 4 sample were randomised without a response status recorded.
- 5 5. After first relapse, all patients received further anti-myeloma treatment (CS p. 89)
- 6 6. After second relapse, [REDACTED] (CS p. 89)

7 The company's anticipated positioning of lenalidomide is as monotherapy to follow ASCT, and
8 maintained until first progression. Because lenalidomide is considered maintenance treatment,
9 the expectation is that, unless there is significant toxicity, it will not be discontinued until first
10 disease progression. The ERG regarded, based on clinical advice, that following lenalidomide
11 maintenance therapy, subsequent lines of treatment after first progression would be unlikely to
12 incorporate lenalidomide. This is in contrast to lines of treatment after observation before first
13 progression, which would be expected to include lenalidomide.

14 Lenalidomide was received over 21 days with a 7-day break, as is consistent with UK clinical
15 practice. However, the average relative dose intensity (RDI) of lenalidomide in the trial was
16 reported to be [REDACTED] (CS, Document B, p. 83), though the methods for calculating this were
17 unclear (see Section 4.2.8.1). The number of patients reported to receive a dose reduction was
18 [REDACTED] (Clarification A11), but clinical advice to the ERG suggests that the RDI may represent the
19 use of dose delays as well as reductions. Clinical advice to the ERG is that the use of a 7 day
20 treatment break per month, and the use of dose delays and reductions, will increase the length
21 of time that patients will tolerate treatment. The efficacy and toxicity of lenalidomide
22 maintenance therapy may therefore be expected to be the way in which lenalidomide is
23 administered in practice.

24 Clinical advice to the ERG is that in UK practice patients receiving lenalidomide maintenance
25 will be seen by their oncologists and haematologists on a more frequent basis than patients
26 under observation, though it is unclear from the CS or the Myeloma XI⁷ trial protocol whether
27 this was permitted during the trial. This is noted in the ERG's quality assessment of the
28 Myeloma XI⁷ trial (Section 3.2.5), as the ERG considered it possible that variation in the number
29 of appointments received between the trial arms could impact on clinical outcome (for example,
30 if progression or AEs are identified and treated earlier).

31 In the CS, the company stated that all patients received further antimyeloma therapy following
32 progression, and [REDACTED] received treatment after a second progression. Subsequent therapies

1 received by patients following progression were not reported in the CS, as the company stated
2 that the therapies used in the trial are unlikely to represent current practice in the UK. While this
3 may be accurate, the ERG noted that this means that longer-term follow-up from Myeloma XI⁷
4 data (i.e. data beyond the main outcomes reported in the CS, such as PFS2) does not represent
5 the treatment pathway that would currently be used.

6 3.2.1.3. Outcome ascertainment and statistical methods used

7 Data in the target population were presented for overall survival (OS), progression-free survival
8 (PFS), and safety (adverse events; AEs). At clarification, the company further provided time to
9 progression data, which was an outcome in the NICE scope for this appraisal. Outcomes were
10 measured appropriately, although the ERG noted that

11 [REDACTED]. The trial is ongoing, though
12 median planned follow-up has been reached (31 months, IQR 18-50). Progression was defined
13 by standard diagnostic criteria, as assessed by a masked panel of experts. The ERG regarded
14 that these procedures were strong, especially given the open-label nature of the trial. However,
15 the ERG regarded measurement of AEs for the target population was poor: limited data were
16 reported, and only for patients receiving lenalidomide maintenance (i.e. no comparative AE data
17 in the observation arm). While in the company's economic model the company take a
18 conservative approach in assuming that the rate of AEs in the observation arm were 0% (cross-
19 refer), the lack of this data in the CS precludes an understanding of the risks of toxicity in the
20 target population.

21 As reported in the CS (CS, Document B, Table 14), OS and PFS in the decision problem cohort
22 were analysed using Cox proportional hazards models stratified by several factors, including
23 treatments received in induction and intensification. While the company stated that full
24 stratification details were reported in Appendix M of the CS, the ERG could not locate this
25 information. This precludes a full understanding of both trial design and the effectiveness of
26 stratification. Tests of the proportional hazards assumptions for these outcomes were presented
27 elsewhere in the submission (CS, Section B.3.2.5) and were visual in nature, but confirmed the
28 appropriateness of the chosen statistical approach.

29 While the company noted that the Myeloma XI⁷ trial was powered to detect a survival benefit for
30 lenalidomide maintenance, the ERG noted that this is based on power calculations using a
31 broader sample than the subgroup used for this appraisal. As this was a post-hoc analysis, no
32 pre-planned power calculations were conducted for this subgroup. While at clarification (A17)

1 the company suggested that statistically significant findings for OS and PFS support power
2 calculations for the wider trial, this does not in itself demonstrate that analyses for this subgroup
3 were sufficiently powered.

4 As the company only included one trial, Myeloma XI⁷ in the SLR, no pairwise meta-analysis was
5 conducted.

6 3.2.1.4. Generalisability to the current UK context

7 Clinical advice to the ERG is that the inclusion criteria for the Myeloma XI⁷ trial were appropriate
8 to the decision problem, and that baseline characteristics of included patients generally matched
9 the patient population that would be treated in the UK. One advisor noted that patients with
10 renal failure who did not recover in the 3 days allowed within the trial design would be excluded,
11 and that these represent a minority (1 in 20) of patients treated in the UK. There was a
12 discrepancy between the ERG's clinical advisors about whether the response rates following
13 induction were consistent with UK practice or not: one advisor considered that they were
14 consistent, while another considered that the rate of complete or very good partial response
15 (80.5%) was higher than would normally be expected, and possibly representative of the
16 specialist care delivered within the centres used in the trial. This therefore remains an area of
17 uncertainty.

18 Clinical advice to the ERG is that the treatments received by patients in the trial appear to be
19 consistent with those that would be used in UK clinical practice outside of the trial context. This
20 includes the dose of lenalidomide maintenance therapy (21 days with a seven-day break), and
21 the use of dose reductions and delays. However, clinical advice to the ERG is that the range of
22 re-induction therapies used in the Myeloma XI trial⁷ are no longer consistent with current
23 practice in the UK; notably, the use of CTD has reduced in the UK since the start of the trial, as
24 other therapies perceived to be more effective are used more frequently. The ERG were also
25 advised that patients with a partial response would normally go on to receive ASCT without
26 intensification. Intensification therapy in the UK may include PAD as well as VCD, and would
27 generally only be administered to patients who do not show a partial response or who
28 demonstrate response but then progress. The company noted (CS, p.90) that anti-myeloma
29 treatments received by patients at second and third line may no longer represent current
30 practice in the UK, due to changing treatment over time, and the availability of some drugs
31 through the NICE CDF.

1 While induction treatment for MM has improved since the Myeloma XI⁷ trial, which may
2 generally result in a higher likelihood of response following ASCT, the ERG were advised that
3 the data in Myeloma XI⁷ were still applicable to current UK practice. Clinical advice to the ERG
4 highlighted that the target population for lenalidomide maintenance are those who achieve a
5 response following ASCT, and that the effect of lenalidomide would not vary according to the
6 induction therapy received. Moreover, clinical advice indicated that the effect of lenalidomide
7 should be consistent amongst any additional patients who achieve a response with the more
8 modern therapies. However, the ERG considered that variation in therapies received at second-
9 and third-line between the Myeloma XI trial and UK clinical practice may have a meaningful
10 impact on the longer-term clinical effectiveness of lenalidomide therapy (see Section 4.2.3).

11 3.2.2. Baseline characteristics

12 Baseline characteristics for patients included in primary analyses were reported in Section B of
13 the CS (p.42), and the ERG did not identify any differences in baseline characteristics between
14 the two arms. Broadly, clinical advice to the ERG is that baseline characteristics reported in the
15 CS cover the majority of prognostic markers in MM. However, clinical advisors note that the
16 revised ISS would have been preferred, as this incorporates cytogenetics and serum LDH, both
17 of which are known prognostic markers. As the statistical analysis plan for Myeloma XI⁷
18 specifies that cytogenetic risk would be analysed as a subgroup of the patient population, the
19 ERG therefore considered this would have been measured even though it was not reported in
20 the CS. At clarification, the ERG requested a breakdown of induction treatments and response
21 to induction by treatment arm, though these were not provided. However on the basis of clinical
22 advice the ERG did not consider that differences in baseline in these factors would have a
23 meaningful impact on the trial results. On the basis of the information provided, there were no
24 discernable differences at baseline between treatment arms in terms of population
25 characteristics.

26 3.2.3. Clinical effectiveness results

27 Median follow-up in the trial was 31 months (IQR 18–50). The ERG considered that the
28 evidence presented for the key outcomes suggested an improvement in OS and PFS from
29 lenalidomide maintenance therapy as compared to observation.

1 3.2.3.1. Overall survival

2 Overall survival (OS) data reported from Myeloma XI⁷ showed a lower absolute number of
3 deaths for the lenalidomide arm ([REDACTED]) than the observation arm ([REDACTED]). After
4 accounting for patient censoring, lenalidomide maintenance was shown to be associated with a
5 [REDACTED] reduction in the risk of all-cause mortality at any one time ([REDACTED]).
6 Confidence intervals around the effect showed some potential variation in the size of the effect,
7 indicating that lenalidomide maintenance may result in a [REDACTED] or greater reduction in the risk of
8 mortality. These data are therefore consistent with lenalidomide maintenance offering a clinically
9 meaningful benefit to OS as compared to observation, at final follow-up. The company provided
10 a Kaplan-Meier plot (CS, Document B, Figure 7) and the visual test of proportional hazards (CS,
11 Section B.3.2.5) suggested that the Cox model used was appropriate. Median survival time
12 [REDACTED] months (doc B table 15) in the
13 observation arm. The median survival time for the lenalidomide arm is available from parametric
14 modelling however (section 4.2.6), and was [REDACTED] under the joint model preferred by the
15 ERG, and [REDACTED] under the independent model preferred by the company (ERG calculation
16 but information not available to obtain CIs).

17 At clarification (A22) the company provided OS data separately for the pre- and post-
18 progression period. Very few deaths occurred prior to progression in either of the trial arms:
19 deaths occurred for [REDACTED] and [REDACTED] of patients in the lenalidomide and observation
20 arms, respectively ([REDACTED]). Amongst those patients who progressed before final
21 follow-up, [REDACTED]
22 and [REDACTED] of patients in the lenalidomide and observation arms died at final follow-up,
23 respectively. However, median survival data indicated that

24 [REDACTED]
25 [REDACTED] ([REDACTED]
26 ([REDACTED]). Furthermore the ERG believes interpretation of post-progression
27 survival requires considerable caution given the complexity of patient management and the
28 treatment sequence; observation arm patients may for example receive lenalidomide after first
29 progression.

30 3.2.3.2. Progression-free survival

31 Patients receiving lenalidomide maintenance therapy experienced
32 [REDACTED] (defined as time until death or first progression) as compared to patients

1 allocated to observation (median PFS, [REDACTED]) in the lenalidomide arm
 2 and [REDACTED] months in the observation arm). This translated to a [REDACTED] reduced risk of
 3 death or progression for patients receiving lenalidomide at any one time as compared to
 4 observation ([REDACTED]). The 95% confidence intervals indicate a potential range
 5 of [REDACTED] for the true effect of lenalidomide compared to observation, though all possible effects are
 6 consistent with a clinical benefit for patients. Data are consistent with a [REDACTED] or greater reduction
 7 in the risk of death or progression compared to observation. The company provided a Kaplan-
 8 Meier plot (CS, Document B, Figure 6) and tests of proportional hazards provided in the CS (CS
 9 Section B.3.2.5) and at clarification (A14) suggested that the Cox model used was appropriate.

10 During clarification (B13), the company also provided data for PFS2 in the decision problem
 11 cohort (defined as time to death or second progression; see Table 5), which also showed a
 12 [REDACTED]
 13 [REDACTED] ([REDACTED]). Confidence intervals showed that the true effect of lenalidomide
 14 as compared to observation may vary by [REDACTED] though all possible effect sizes are consistent with
 15 a clinical benefit for patients. However the company note that these data are as yet “very
 16 *immature*” (Clarification B13), [REDACTED].
 17 Furthermore, the ERG noted that therapy following first progression in these patients does not
 18 reflect current practice (Section 3.2.1.2). Generally the ERG consider composite outcomes to be
 19 less informative to understanding the clinical effect of treatments as compared to disaggregated
 20 outcomes, and at clarification requested (A22) that the company provide disaggregated data for
 21 progression (Section 3.2.3.3).

22 **Table 5: Second-progression-free survival in decision problem cohort**

Treatment	N	Events	Censored	Median (months; 95% CI)	HR (95% CI)
Lenalidomide	621	[REDACTED]	[REDACTED]	[REDACTED]	[REDACTED]
Observation	411	[REDACTED]	[REDACTED]	[REDACTED]	[REDACTED]

23 Key CI, confidence interval, HR, hazard ratio; NA, not applicable

24
 25 **3.2.3.3. Time to progression**

26 The findings presented during clarification (A22) demonstrate that a [REDACTED] of patients
 27 receiving lenalidomide maintenance experienced disease progression compared to those
 28 receiving observation: [REDACTED] in the lenalidomide arm and [REDACTED] in the
 29 observation arm. [REDACTED] in the lenalidomide arm than observation: time
 30 to progression (TTP) was a median of [REDACTED] for patients in the

1 lenalidomide arm, compared to [REDACTED] for patients in the observation arm,
2 showing evidence of [REDACTED]. The company
3 noted that the low number of patients in the lenalidomide arm who are at risk when the median
4 is reached adds uncertainty to the data (Clarification B10).

5 3.2.3.4. Health-related quality of life

6 Within-trial HRQoL data were not collected.

7 3.2.3.5. Subgroup analyses

8 The company did not report subgroup analyses conducted within the target population for this
9 appraisal. Rather, the company reported the findings of subgroup analyses conducted for the
10 overall post-ASCT population for Myeloma XI⁷ were presented in the CS (Appendix F). Because
11 these included transplant-eligible and transplant-ineligible patients alongside the multiple
12 lenalidomide monotherapy maintenance arms used in the trial, the ERG did not regard these as
13 probative to the decision problem.

14 3.2.4. Adverse effects (AEs, SAEs and causes of death)

15 3.2.4.1. Adverse events and serious adverse events

16 Section B.1.10.1 of the CS provided data on Grade 1 to 5 AEs for the ASCT-eligible population
17 of Myeloma XI.⁷ These data were only given for the [REDACTED] participants receiving at least one dose
18 of lenalidomide as maintenance treatment, and indicated that the most frequently reported AEs
19 were

20 [REDACTED]
21 [REDACTED]
22 [REDACTED]
23 [REDACTED]

24 [REDACTED] The ERG could not check the accuracy of these data because separate analyses on the
25 ASCT-eligible population were not planned (Clarification A16) or provided in the relevant
26 publication.⁷ It is also not clear why these data were not presented for the observation arm.
27 Absence of observation arm data precludes meaningful between-arm comparisons for the
28 decision problem cohort. Similar data were also presented for the Myeloma XI ITT population
29 (comprising both ASCT and non-ASCT patients; CS, Appendix F, Tables 12 and 13). The ERG
30 checked these data against the primary publication for the study⁷ and found no errors in
31 reporting. However, these data also only included the lenalidomide arm and not the observation

1 arm and were, therefore, not particularly informative. The number of patients reported to receive
 2 a dose reduction was ■ (Clarification A11); however the number of patients who received
 3 treatment breaks, or who discontinued treatment due to adverse events, were not reported.

4 Further data on serious adverse events (SAEs) were provided for both the lenalidomide arm
 5 and the observation arm (CS, Appendix F, Table 14) but were only provided for the Myeloma XI
 6 ITT population and not for the ASCT-eligible cohort. These data indicated that, for the whole ITT
 7 population, at least one SAE occurred in 45% of the lenalidomide arm and 17.2% of the
 8 observation arm. Approximately half (50.2%) of these SAEs were infections in the lenalidomide
 9 arm and approximately a third (34.4%) were infections in the observation arm. It is not clear to
 10 what extent these data can be used as a proxy for the ASCT-eligible cohort. However, the ERG
 11 concur that large differences in these SAEs would not be expected between the ASCT-eligible
 12 and -ineligible cohorts, although ASCT-ineligible patients might be more frail and ASCT-eligible
 13 participants might be more likely to have increased vulnerability following the ASCT procedure,
 14 particularly with regards to fatigue.

15 3.2.4.2. Causes of death

16 The company reported that there were no deaths related to treatment with lenalidomide (CS,
 17 Section B.1.10.2). This is consistent with the main publication.⁷ Further detail on causes of
 18 death were provided in the publication, for the whole Myeloma XI sample, for the ASCT-eligible
 19 sample and for the ASCT-ineligible sample. The ERG has presented the data from the former
 20 two samples in Table 6. It is not clear why the numbers included in the ASCT-eligible sample
 21 are larger than expected (n=730 in the lenalidomide arm and n=518 in the observation arm),
 22 and there is a possibility that these data include patients receiving different doses of
 23 lenalidomide and/or those receiving vorinostat in addition to lenalidomide.

24 **Table 6: Causes of death**

Cause of death	Overall*		ASCT-eligible	
	Lenalidomide (n=1137)	Observation (n=834)	Lenalidomide (n=730)	Observation (n=518)
Death — no. (%)				
Yes	234 (20.6)	226 (27.1)	84 (11.5)	98 (18.9)
No	903 (79.4)	608 (72.9)	646 (88.5)	420 (81.1)
Primary cause of death progressive disease — no. (%)				
Yes	155 (66.2)	161 (71.2)	64 (76.2)	73 (74.5)
No	73 (31.2)	59 (26.1)	19 (22.6)	23 (23.5)

Missing	6 (2.6)	6 (2.7)	1 (1.2)	2 (2.0)
Primary cause of death (myeloma related) — no. (%)				
Overwhelming tumor load	118 (50.4)	113 (50.0)	44 (52.4)	54 (55.1)
Infection	30 (12.8)	39 (17.3)	13 (15.5)	16 (16.3)
Renal failure	11 (4.7)	19 (8.4)	6 (7.1)	8 (8.2)
Skeletal	1 (0.4)	0 (0.0)	0 (0.0)	0 (0.0)
Primary cause of death (non-myeloma related) — no. (%)				
Cardiac	11 (4.7)	10 (4.4)	4 (4.8)	2 (2.0)
Respiratory	11 (4.7)	12 (5.3)	2 (2.4)	3 (3.1)
Abdominal	4 (1.7)	2 (0.9)	1 (1.2)	0 (0.0)
Neurological	4 (1.7)	1 (0.4)	2 (2.4)	1 (1.0)
Other malignancy	27 (11.5)	9 (4.0)	7 (8.3)	2 (2.0)
Other	11 (4.7)	12 (5.3)	4 (4.8)	8 (8.2)
Missing	6 (2.6)	9 (4.0)	1 (1.2)	4 (4.1)

1 Key: ASCT, autologous stem cell transplantation

2 Notes: * Whole Myeloma XI sample, includes ASCT-ineligible and ASCT-eligible samples

3 Source: Jackson et al. (2019),⁷ supplementary materials⁸

4

5 3.2.5. Quality assessment of the Trials of the Technology of Interest

6 The company evaluated the risk of bias in Myeloma XI⁷ using the Cochrane Risk of Bias tool,
7 which is standard SLR methodology. The ERG re-assessed risk of bias using the published
8 literature, whilst also considering that the data presented in the company submission were
9 based on a subsample of the whole Myeloma XI population.⁷

10 The company's assessment is reproduced in Table 7, alongside the ERG assessment. The
11 ERG assessment evaluated the risk of bias in Myeloma XI⁷ specifically for the outcomes
12 reported in the company submission (primarily OS, PFS and also AEs). The ERG's risk of bias
13 assessment was mainly in agreement with the company's assessment. However, because the
14 data presented in the submission were based on a study subsample, the ERG noted that
15 analyses for the relevant subsample were not pre-planned or published. This accounts for the
16 differences between the company and the ERG in the rating of items 5.1 and 5.3 of Table 7.
17 Because the analyses were performed to enable a good fit with the decision problem, lack of
18 pre-planning would be unlikely to result in substantial bias.

19 The ERG highlighted the open-label design of Myeloma-XI;⁷ it is unclear why open-label
20 treatment with lenalidomide was used, when a previous trial conducted by the company
21 (CALGB 100104^{3,4}) was able to administer lenalidomide in a double-blind fashion. It is probable

1 that the design was chosen for pragmatic and logistical reasons (e.g. so that clinicians only
 2 needed to administer pregnancy tests for one arm of the study). For the primary outcomes in
 3 Myeloma XI (PFS and OS), the risk of bias arising from lack of blinding is likely to be low,
 4 however for some safety data the risk of bias might be higher. This is further discussed in
 5 Section 3.5.3.

6 An advisor to the ERG noted that in UK practice patients receiving lenalidomide maintenance
 7 would be seen by clinicians more frequently than those under observation. It is unclear from the
 8 available information whether this was the case within the Myeloma-XI trial,⁷ which the company
 9 states is consistent with UK practice. More frequent appointments with clinicians could affect
 10 treatment outcomes, for example if adverse events or signs of progression are identified and
 11 managed earlier. However, on the basis of the information available to the ERG, this remains an
 12 uncertainty in the evidence.

13 **Table 7: Company and ERG Quality Appraisal of Myeloma XI**

	Company Appraisal	ERG Appraisal
1. Randomisation process		
1.1 Was the allocation sequence random?	Y	Y
1.2 Was the allocation sequence concealed until participants were enrolled and assigned to interventions?	Y	Y
1.3 Did baseline differences between intervention groups suggest a problem with the randomisation process?	N	N
Risk of bias judgement	Low	Low
2. Deviations from intended interventions		
2.1 Were participants aware of their assigned intervention during the trial?	Y	Y
2.2 Were carers and people delivering the interventions aware of participants' assigned intervention during the trial?	Y	Y
2.3 If Y/PY/NI to 2.1 or 2.2: Were there deviations from the intended intervention that arose because of the experimental context?	N	N
2.4 If Y/PY to 2.3: Were these deviations likely to have affected the outcome?	NA	NA
2.5 If Y/PY/NI to 2.4: Were these deviations from intended intervention balanced between groups?	NA	NA

2.6 Was an appropriate analysis used to estimate the effect of assignment to intervention?	Y	Y
Risk of bias judgement	Low	Some concerns
3. Missing outcome data		
3.1 Were data for this outcome available for all, or nearly all, participants randomised?	Y	Y
3.2 If N/PN/NI to 3.1: Is there evidence that the result was not biased by missing outcome data?	NA	NA
3.3 If N/PN to 3.2: Could missingness in the outcome depend on its true value?	NA	NA
3.4 If Y/PY/NI to 3.3: Is it likely that missingness in the outcome depended on its true value?	NA	NA
Risk of bias judgement	Low	Low
4. Measurement of the outcome		
4.1 Was the method of measuring the outcome inappropriate?	N	N
4.2 Could measurement or ascertainment of the outcome have differed between intervention groups?	N	N
4.3 If N/PN/NI to 4.1 and 4.2: Were outcome assessors aware of the intervention received by study participants?	N	N
4.4 If Y/PY/NI to 4.3: Could assessment of the outcome have been influenced by knowledge of intervention received?	NA	NA
4.5 If Y/PY/NI to 4.4: Is it likely that assessment of the outcome was influenced by knowledge of intervention received?	NA	NA
Risk of bias judgement	Low	Low
5. Selection of the reported result		
5.1 Were the data that produced this result analysed in accordance with a pre-specified analysis plan that was finalised before unblinded outcome data were available for analysis?	Y	N
5.2 Is the numerical result being assessed likely to have been selected, on the basis of the results, from multiple eligible outcome measurements (e.g. scales, definitions, time points) within the outcome domain?	N	N
5.3 Is the numerical result being assessed likely to have been selected,	N	PN

on the basis of the results, from multiple eligible analyses of the data?		
Risk of bias judgement	Low	Low
Overall bias	Low	Some concerns

1 Key ERG, Evidence Review Group; N, No; NA, not applicable; PN, probably no; PY, probably yes

2

3 3.3. Critique of additional trials identified in the systematic review

4 The company's SLR did not identify any studies evaluating other treatments for maintenance
5 therapy following ASCT in patients with MM. Clinical advice to the ERG concurs with the
6 company that there are currently no other treatments available for this indication.

7 3.4. Critique of the indirect comparison and/or multiple treatment comparison

8 No network meta-analysis was undertaken for this submission.

9 3.5. Additional work on clinical effectiveness undertaken by the ERG

10 As discussed in Section 3.2 the ERG considered that the GIMEMA⁵ and CALGB 100104^{3,4} trials
11 should have been included in the company's clinical effectiveness SLR and thus in the CS, as
12 both trials report evidence evaluating lenalidomide maintenance therapy in the target
13 population. The ERG therefore summarise the methods, clinical findings, and quality
14 assessment for these trials below. However, due to heterogeneity in patient characteristics
15 between these and the Myeloma XI⁷ trial, and the paucity of data reported for the two trials, no
16 meta-analysis of the trials was possible.

17 The company presented a comparative summary of clinical efficacy data from CALGB
18 100104,^{3,4} GIMEMA,⁵ and Myeloma XI⁷ in the CS (Doc B, Table 17, p. 60-61), although the
19 ERG noted that key data for the specified outcomes were missing, and follow-up timepoints
20 were also not specified, which hampered comparison.

21 3.5.1. GIMEMA

22 The company excluded the GIMEMA⁵ trial from their SLR because the study sample included
23 both ASCT and non-ASCT patients (the latter received consolidation therapy with melphalan,
24 prednisone and lenalidomide prior to the maintenance phase of the study). However, the ERG
25 identified relevant OS and PFS data (Section 3.5.1.2) for the ASCT-eligible patients in the text
26 and figures of the primary publication.⁵ The ERG acknowledge that these data are extremely
27 limited, and that the study was not powered to investigate treatment differences in the cohort
28 relevant to the decision problem, but these are presented for completeness.

1 **3.5.1.1. GIMEMA Methods**

2 GIMEMA⁵ was a Phase III, randomised, open-label trial that included a maintenance phase
3 where patients were allocated to lenalidomide maintenance therapy or to no maintenance.
4 Between November 2007 and July 2009, 402 patients were initially recruited via 62 centres in
5 Italy and Israel. Following the induction phase of the study, 273 patients were eligible to receive
6 either melphalan with ASCT or consolidation with melphalan, prednisone and lenalidomide. Of
7 these patients, 251 went on to enter the maintenance phase of the study, 135 of whom had
8 received an ASCT (67 were randomised to lenalidomide and 68 to no maintenance treatment).

9 Patient characteristics were only available for the whole sample (n=402) or for all those who
10 received maintenance therapy or no maintenance therapy (inclusive of ACST and non-ASCT
11 patients)⁵ All patients were aged ≤65 years and had received induction therapy with
12 lenalidomide and dexamethasone. In the ASCT cohort, stem cells were mobilised using
13 cyclophosphamide and granulocyte colony-stimulating factor, followed by high-dose melphalan
14 and ASCT. The lenalidomide maintenance arm received 10mg of lenalidomide on days 1-21 of
15 each 28-day cycle, until disease progression or discontinuation due to AEs. The comparator
16 arm received no maintenance treatment. The median length of follow up for the study was 51.2
17 months (38.8 months for the maintenance phase).

18 Adverse event data were not provided for the cohort relevant to the decision problem.

19 **3.5.1.2. GIMEMA Clinical Efficacy Results**

20 The clinical efficacy data for the ASCT-eligible cohort are provided in Table 8, alongside the
21 PFS and OS data from Myeloma XI.⁷ The data from the lenalidomide arm in GIMEMA⁵ appear
22 to be supportive of the data from Myeloma XI.⁷ However, the no maintenance control arm in
23 GIMEMA appear to have a longer PFS than the no maintenance arm in Myeloma XI (Table 8).
24 Reasons for this are unclear but may be due to differences between studies in patient
25 characteristics. However, the ERG could not investigate this possibility further because patient
26 characteristics were not provided separately for the ASCT-eligible cohort in GIMEMA.⁵

27 The ERG calculated HRs for PFS and OS using the data from the ASCT-eligible cohort in
28 GIMEMA.⁵ Information (survival curve and numbers at risk) were extracted from figure 2A in
29 Palumbo et al. (2014)⁵ for the ASCT subgroups and analysed using the methods and calculator
30 provided by Tierney et al. (2007).⁹ In this survival curve, results are referenced to the time of
31 diagnosis, which included an induction period of approximately 4 months, 'consolidation' of 8

1 months, with lenalidomide maintenance beginning within the first 3 months after completion of
 2 consolidation therapy. In order to relate to the maintenance period only, the pooled hazard ratio
 3 was therefore calculated on the basis of follow-up from the first available timepoint (18 months)
 4 since diagnosis, when all patients are thought to have entered the maintenance phase. Results
 5 of the ERG calculations are provided in Table 8.

6 The ERG noted that the magnitude of HRs is similar between GIMEMA⁵ and Myeloma XI⁷ for
 7 PFS (0.44 vs 0.46) and for OS (0.74 vs 0.61). In GIMEMA, as in Myeloma XI, there is statistical
 8 evidence of improved PFS with lenalidomide maintenance treatment compared with no
 9 maintenance treatment. There is no statistical evidence of improved OS in GIMEMA, but this
 10 result should be interpreted with caution because the GIMEMA⁵ study was not powered to
 11 detect between-arm differences in the ASCT cohort. The analysis also contains inevitable
 12 inaccuracies when extracting survival data from published curves, and because the precise
 13 entry times to the maintenance phase are not available.

14 **Table 8: GIMEMA Clinical Efficacy Data; and in Comparison to Myeloma XI**

	GIMEMA*	Myeloma XI
Follow-up (median, range)	38.3 months (IQR NR)	31 months (IQR 18-50)
PFS	HR [‡] = 0.44, 95% CI 0.26, 0.75 Median (95%CI) [∞] Len: 54.7 months (NR) No maintenance: 37.4 months (NR)	
OS	HR [‡] 0.74; 95% CI 0.34, 1.62 5 year OS Len: 78.4% No maintenance: 66.6%	

15 Key: CI, confidence interval; ERG, Evidence Review Group; GIMEMA, Gruppo Italiano Malattie EMatologiche
 16 dell'Adulto; HR, hazard ratio; IQR, interquartile range; Len, lenalidomide; OS, overall survival; PFS, progression
 17 free survival

18 Notes: * Data from the ASCT cohort; ‡Calculated by the ERG; ∞ Note that these are based on the ITT population, and
 19 may include participants who did not receive an ASCT despite being allocated to receive one. They are also
 20 based on the time since diagnosis, and so include a minimum of 12 months of induction and consolidation
 21 therapy.

22 Source: Palumbo 2014;⁵ CS, Doc B, p. 47-48

23
 24 **3.5.2. CALGB 100104**

25 The company stated that they excluded the CALGB 100104^{3,4} trial from their SLR as the
 26 standard dose used in the trial (10 mg per day across a 28 day cycle) is higher than that
 27 currently used in UK clinical practice (10 mg per day across a 21-day cycle, followed by a

1 seven-day break). A dose increase to 15mg per day was also permitted in CALGB 100104,^{3,4}
2 which the company claim would not be used in UK clinical practice. Clinical advice to the ERG is
3 consistent with this; clinicians in the UK only administer lenalidomide at a maximum dose of 10
4 mg over a 21-day cycle, considering that this limits toxicity and increases the length of time that
5 patients can tolerate treatment. However, the ERG noted that dosing used in CALGB 100104^{3,4}
6 is consistent with the SmPC^{10,11} and marketing authorisation¹² for lenalidomide in this
7 population, and therefore is not inconsistent with potential dosing of lenalidomide maintenance
8 and should therefore be included and considered within this appraisal. Moreover, the company
9 used data from the CALGB 100104 trial to validate assumptions used in their economic model,
10 after judging that trial populations were sufficiently similar for comparison (CS, p.68; based on
11 data from the observational arm). Finally, as the trial benefitted from a longer follow-up duration
12 (10.5 years maximum), the ERG considered that appraisal of data from CALGB 100104^{3,4} may
13 be valuable. The ERG have therefore summarised the methods and findings of the CALGB
14 100104 trial below, for the committee's consideration. Quality appraisal of CALGB 100104 has
15 also been conducted and is reported in Table 11.

16 3.5.2.1. CALGB 100104 Methods

17 CALGB 100104^{3,4} was a Phase III, randomised, double-blind, placebo-controlled trial involving
18 460 patients recruited between April 2005 and July 2009 from 47 centres in the US. Patients
19 were aged between 29 and 71 years, 54.3% male, and with an ECOG performance status of 0
20 or 1. All patients had stable disease or a marginal, partial, or complete response following
21 ASCT. Patients had received a range of induction therapies, including combinations of
22 bortezomib, lenalidomide, or thalidomide; a total of 35% had received lenalidomide in their
23 induction treatment. Patients were unblinded on December 17, 2009, after a median follow-up of
24 18 months. At this point, patients in the placebo arm were permitted to switch to receive
25 lenalidomide. The trial is reported across two primary publications: McCarthy (2011),⁴ from
26 which follow-up data up at 18 months (at unblinding) and 34 months was reported (34-month
27 data were reported in the CS (Document B, Table 10); and Holstein (2017),³ which reported
28 data up until a median of 91 months (range NR). Outcome data at all timepoints is primarily
29 calculated with the ITT population set; although in the appendix of the CS (Appendix O p. 134-
30 135) OS and PFS data at the final follow-up is adjusted for treatment switching.

31 Time on treatment for patients in the CALGB 100104 trial was considerably shorter (median
32 25.4 months, 95% CI 19.9 - 30.8, n=224) than was reported in Myeloma XI
33 ([REDACTED]). This is consistent with clinical advice to the ERG that the

1 higher dose and absence of a monthly treatment break may lead to increased toxicity and
 2 reduce the length of time that patients could tolerate treatment.

3 **3.5.2.2. CALGB 100104 Clinical Efficacy Results**

4 Clinical efficacy outcome data for the ITT participant set is reported in Table 9 below.

5 CALGB 100104^{3,4} reports a large, statistically significant benefit of Lenalidomide for PFS and
 6 OS as compared to placebo. While wide 95% confidence intervals around the effect were
 7 reported, all bounds were consistent with a clinically meaningful benefit for patients. CALGB
 8 100104^{3,4} reported relative effect estimates similar to Myeloma XI⁷ at a similar timepoint (31
 9 months in Myeloma XI and 34 months in CALGB 100104). Unsurprisingly, data from CALGB
 10 100104 that was adjusted to account for treatment switching shows a small increase in the
 11 relative effect of lenalidomide. Time to progression and HRQoL were not reported in the trial
 12 publications for CALGB 100104.^{3,4}

13 Comparison of effect size between CALGB 100104^{3,4} and Myeloma XI⁷ was limited due to
 14 differences in the duration of treatment received in each trial. However, broadly speaking, both
 15 trials supported a clinical effect of lenalidomide maintenance therapy for OS and PFS as
 16 compared to placebo (CALGB 100104) and observation (Myeloma XI). As discussed in more
 17 detail in Section 4.2.6, and with reference to the company’s basecase assumptions, the clinical
 18 efficacy data from the CALGB 100104 and Myeloma XI trials do not support an improvement in
 19 treatment effect over follow-up timepoints.

20 **Table 9: CALGB Clinical Efficacy Data; Comparison to Myeloma XI**

	CALGB; McCarthy 2011	CALGB Holstein 2017	Myeloma XI
Follow-up (median, range)	18 months and 34 months	91 months (range NR)	31 months (IQR 18-50)
PFS	<u>18 months</u> HR 0.37 (95% confidence interval [CI], 0.26 to 0.53) Median (95% CI) Len: 39 months (NR) Placebo: 21 months (NR) p<.001 <u>34 months</u> HR 0.48 (95% CI, 0.36 to 0.63) Median (95% CI)	Unadj HR 0.57 (95% CI 0.46-0.71, p<.0001) [*] Median (95%CI): Len: 57.3 months (44.2–73.3) Placebo: 28.9 months (23.0–36.3) Adj HR 0.53 (95%CI 0.42, 0.72) Median (95%CI)	

	Len: 46 months (NR) Placebo 27 months (NR) p<.001	Placebo: 26.3 (20.3, 34.6)	
TTP	NR	NR	NR
OS	18 months HR 0.52; 95%CI 0.26 - 0.53) Median survival not reached for either group 34 months HR 0.62 (95% CI, 0.40 - 0.95)	Unadj HR 0.61 (95%CI 0.46-0.80; p=.0004) [‡] Median OS (95%CI) Len: 113.8 months (100.4-not reached) Placebo: 84.1 months (73.8–106.0) Adj HR 0.47 (0.35, 0.62) Median (95%CI) Placebo: 26.3 (20.3, 34.6)	
HRQoL	NR	NR	NR

1 Key: Adj, adjusted (RPSFT adjustments for treatment switching); CALGB, Cancer and Leukaemia Group B; CI, confidence interval; HR, hazard ratio; NR, not reported; Unadj, unadjusted

2
3 Notes: * Unadjusted HR reported in CS, Appendix O = 0.63 (95%CI 0.50,0.78); [‡]Unadjusted HR reported in CS, Appendix O = 0.61 (95%CI 0.47, 0.81).

4
5 Source: McCarthy 2011;⁴ Holstein 2017;³ CS Doc B; CS Appendices p. 133-135.

6

7 **3.5.2.3. CALGB Adverse Effects and Comparison with Myeloma XI**

8 Adverse event data for CALGB 100104^{3,4} in the per protocol population were extracted from the
9 trial publications. Summary AE outcomes are reported in Table 10. At the first data cut-off,⁴
10 more than half of patients receiving lenalidomide experienced at least one AE, though very few
11 Grade 4 and Grade 5 AEs were reported. A total of 10% of patients receiving lenalidomide
12 discontinued treatment due to AEs, as compared to 1.4% in the placebo arm. Grade 3 rates of
13 fatigue, febrile neutropenia, infection, diarrhea, and rash were higher in the lenalidomide arm as
14 compared to placebo. Grade 3 and 4 haematological AEs were also higher in the lenalidomide
15 arm as compared to placebo. The publication did not report whether any deaths were
16 considered to be due to treatment with lenalidomide. Comparison of rates of AEs between
17 CALGB 100104^{3,4} and Myeloma XI⁷ is not possible as the proportion of overall AEs, overall
18 haematological AEs, and the proportion of patients who discontinued due to AEs were not
19 reported in the Myeloma XI trial.

1 **Table 10: Adverse events in CALGB 100104**

	CALGB 100104; McCarthy 2011
Follow-up (median, range)	Unclear. Data cut-off was February 2012; median follow-up as of October 31 2011 was 34 months
Discontinuation due to AEs	Len: 23/231 (10.0%) PBO: 2/143 (1.4%)
Overall AE	Len: 138/231 (59.7%) PBO: 69/229 (30.1%)
Haematologic AEs	Len: Grade 3 74/231 (32.0%); Grade 4 36/231 (15.6%) PBO: Grade 3 27/229 (11.8%), Grade 4 12/229 (5.2%)

2 Key: AEs, adverse events; CALGB, Cancer and Leukaemia Group B; Len, lenalidomide; PBO, placebo

3 Source: McCarthy 2011⁴

4

5 3.5.3. Comparative Quality Assessment of GIMEMA, CALGB, and Myeloma XI

6 The ERG performed quality assessments for all three trials (GIMEMA, CALGB 100104 and
7 Myeloma XI).^{3-5,7} The results of these quality assessments are provided, alongside the
8 company's assessment of Myeloma XI, in Table 11. The most notable difference between the
9 trial designs was that both Myeloma-XI and GIMEMA used an open-label design,^{5,7} whereas
10 CALGB 100104^{3,4} was a double-blind placebo controlled trial (until after the 18 month follow-up).
11 Risk of bias due to an open-label design is more pronounced for patient-reported outcomes, and
12 as previously mentioned (Section 3.2.5), the impact of open-label treatment on PFS and OS is
13 likely to be low. However, it is important to consider that lack of blinding of patients and
14 clinicians may have more of an impact on safety data, particularly low-grade and patient-
15 reported adverse events, although the ERG acknowledge that little between-arm safety data are
16 presented in the CS, and no between-arm data are reported for low-grade AEs.

17 For each of the trials, the ERG considered the equity between the lenalidomide maintenance
18 arm and the comparator arm, both with regards to patient characteristics at baseline and in
19 terms of the trial methods. In the Myeloma XI⁷ cohort relevant to the decision problem, baseline
20 patient characteristics were well-balanced across the lenalidomide maintenance and
21 observation groups, although these data were only available in the company submission (CS
22 Section B.1.1.7) and not in the published literature. Likewise, in CALGB 100104, baseline
23 patient characteristics were well-balanced across the lenalidomide maintenance and placebo
24 groups.^{3,4} However, for GIMEMA,⁵ although there were no apparent between-group differences
25 at baseline for the overall study, there were no data on patient characteristics available for the

1 two arms of the ASCT subpopulation. It is therefore unclear whether the relevant study arms
 2 were well balanced with regards to patient baseline characteristics. The ERG noted that, in
 3 Myeloma XI⁷ it was unclear whether patients in the observation arm received the same number
 4 of contact appointments as those in the lenalidomide maintenance arm, whereas in GIMEMA^{5,13}
 5 and CALGB 100104,^{3,4} all patients in the relevant arms attended appointments to the same
 6 schedule. However, because it is unclear whether the observation arm participants in Myeloma
 7 XI⁷ did receive less contact than the lenalidomide arm, it is not possible to establish whether this
 8 might have impacted upon study results.

9 Other key differences between the trials, with regards to the quality assessments, are related to
 10 measurement of outcomes and statistical analyses: It was not clear whether outcome assessors
 11 were blinded to treatment allocation in the GIMEMA⁵ trial, but assessors were blinded in the
 12 Myeloma XI⁷ and CALGB 100104^{3,4} studies. However, as previously discussed, a lack of
 13 blinding would be unlikely to have a major impact on the primary outcomes of interest (OS and
 14 PFS). As previously mentioned (Section 3.2.5), the analyses for the relevant ASCT-cohort in
 15 Myeloma XI⁷ were not pre-planned or published. However, for GIMEMA, these subgroup
 16 analyses were pre-planned¹³ and reported in the primary publication for the study.⁵

17 **Table 11: Quality Appraisal of GIMEMA, CALBG 100104, and Comparison with**
 18 **Myeloma XI**

	Myeloma XI	Myeloma XI ERG Assessment	GIMEMA ERG Assessment	CALGB ERG Assessment
1. Randomisation process				
1.1 Was the allocation sequence random?	Y	Y	Y	Y
1.2 Was the allocation sequence concealed until participants were enrolled and assigned to interventions?	Y	Y	Y	Y
1.3 Did baseline differences between intervention groups suggest a problem with the randomisation process?	N	N	NI	N
Risk of bias judgement	Low	Low	Low	Low
2. Deviations from intended interventions				
2.1 Were participants aware of their assigned intervention during the trial?	Y	Y	Y	N (at 18 month follow-up; then Y)
2.2 Were carers and people delivering the interventions aware of participants' assigned intervention during the trial?	Y	Y	Y	N (at 18 month)

				follow-up; then Y)
2.3 If Y/PY/NI to 2.1 or 2.2: Were there deviations from the intended intervention that arose because of the experimental context?	N	N	N	N
2.4 If Y/PY to 2.3: Were these deviations likely to have affected the outcome?	NA	NA	NA	NA
2.5 If Y/PY/NI to 2.4: Were these deviations from intended intervention balanced between groups?	NA	NA	NA	NA
2.6 Was an appropriate analysis used to estimate the effect of assignment to intervention?	Y	Y	Y	Y
Risk of bias judgement	Low	Low	Low	Low
3. Missing outcome data				
3.1 Were data for this outcome available for all, or nearly all, participants randomised?	Y	Y	Y	Y
3.2 If N/PN/NI to 3.1: Is there evidence that the result was not biased by missing outcome data?	NA	NA	NA	NA
3.3 If N/PN to 3.2: Could missingness in the outcome depend on its true value?	NA	NA	NA	NA
3.4 If Y/PY/NI to 3.3: Is it likely that missingness in the outcome depended on its true value?	NA	NA	NA	NA
Risk of bias judgement	Low	Low	Low	Low
4. Measurement of the outcome				
4.1 Was the method of measuring the outcome inappropriate?	N	N	N	N
4.2 Could measurement or ascertainment of the outcome have differed between intervention groups?	N	N	N	N
4.3 If N/PN/NI to 4.1 and 4.2: Were outcome assessors aware of the intervention received by study participants?	N	N	PY	N
4.4 If Y/PY/NI to 4.3: Could assessment of the outcome have been influenced by knowledge of intervention received?	NA	NA	PN	NA
4.5 If Y/PY/NI to 4.4: Is it likely that assessment of the outcome was influenced by knowledge of intervention received?	NA	NA	PN	NA
Risk of bias judgement	Low	Low	Low	Low

5. Selection of the reported result				
5.1 Were the data that produced this result analysed in accordance with a pre-specified analysis plan that was finalised before unblinded outcome data were available for analysis?	Y	N	Y	Y
5.2 Is the numerical result being assessed likely to have been selected, on the basis of the results, from multiple eligible outcome measurements (e.g. scales, definitions, time points) within the outcome domain?	N	N	N	N
5.3 2 Is the numerical result being assessed likely to have been selected, on the basis of the results, from multiple eligible analyses of the data?	N	PN	PN	PN
Risk of bias judgement	Low	Low	Low	Low
Overall bias	Low	Low	Low	Low

1 Key: CALGB, Cancer and Leukemia Group B; ERG, Evidence Review Group; GIMEMA, Gruppo Italiano Malattie
2 EMatologiche dell'Adulto; N, no; NA, not applicable; NI, no information; PN, probably no; PY, probably yes; Y, yes

3
4 Other differences between the trials included the fact that only Myeloma XI was conducted on a
5 UK population,⁷ with GIMEMA being conducted in Italy and Israel,⁵ and CALGB 100104
6 conducted in the US.^{3,4} This issue is associated with external validity rather than internal validity
7 (i.e. it does not mean that Myeloma XI is of better quality than the other two trials, but might
8 mean that it is more relevant to the decision problem). Related to this is the fact that a different
9 lenalidomide dosing schedule (Section 3.5.2.1) was used in CALGB 100104 than in the other
10 two trials. This may impact upon the study results (e.g. may increase toxicity and reduce the
11 length of time on treatment).

12 3.6. Conclusions of the clinical effectiveness section

13 The ERG did not consider that the CS represented a comprehensive evidence base for this
14 submission. As the main evidence presented was generated from an unplanned comparison in
15 a larger trial, some outcomes relevant to the NICE scope were not measured within the trial
16 design (e.g. HRQoL, and AEs for the observation arm), and thus were not available. However,
17 further to this, some data measured in the trial were not reported in the CS, and evidence from
18 two RCTs meeting the inclusion criteria for the appraisal were not presented. Given that the
19 main evidence presented in the CS is not published elsewhere, and was not included in the trial
20 clinical study report, few other sources were available for the ERG to complete and validate the
21 evidence base. While the ERG were able to access some relevant data from the company at

1 clarification, not all requests were fulfilled, and further gaps in the evidence base became
2 evident during the appraisal. In addition, the ERG considered evidence relevant to this appraisal
3 had been omitted from the CS and, as such, this led to concerns of reporting bias resulting in a
4 lack of confidence in the reliability of the data reported.

5 The evidence base for lenalidomide maintenance (Myeloma XI,⁷ GIMEMA⁵ and CALGB
6 100104^{3,4}) considered by the ERG was generally high quality. Despite heterogeneity between
7 the trial designs, the data were consistent with a beneficial effect of lenalidomide maintenance
8 therapy for OS and PFS in patients with newly diagnosed MM, following ASCT. The ERG
9 consider it likely that lenalidomide would be of benefit to patients for these outcomes, although
10 noted that wide variability around the treatment effect estimates, and the small, heterogeneous
11 evidence base, means that the potential magnitude of the treatment effect of lenalidomide is
12 uncertain.

13 Lenalidomide is associated with known toxicity, and in current clinical practice this is managed
14 through dose reductions and treatment breaks in order to prolong treatment duration. Based on
15 the evidence presented and advice from clinical advisors to the ERG, a 21 day treatment cycle
16 with a 7 day break, as used in the Myeloma XI⁷ trial, seems to prolong treatment duration.
17 Insufficient evidence was presented in the CS in order to estimate the risk of AEs associated
18 with lenalidomide maintenance in the target population. However, based on clinical advice the
19 ERG considered it likely that rates would be similar to the ITT population in Myeloma XI,⁷ which
20 included patients who had not received ASCT. On this basis, the ERG considered it unlikely that
21 lenalidomide maintenance would result in an unacceptable risk of SAEs. However, the ERG
22 note that in the absence of relevant evidence, the risks of treatment with lenalidomide therapy in
23 these patients remains unclear.

24 There is no evidence to evaluate the effects of lenalidomide maintenance therapy on HRQoL, or
25 on other patient-reported outcomes. This data may have been useful, in order to balance the
26 relative impact of clinical benefits and AEs.

1 4. COST-EFFECTIVENESS

2 4.1. ERG comment on company's review of health economic evidence

3 The company carried out a SLR, using three separate search strategies, to identify existing
4 cost-effectiveness evidence, HRQoL evidence, and cost and resource use of maintenance
5 treatment in patients with newly-diagnosed MM who are either undergoing or eligible for ASCT.

6 4.1.1. Cost-effectiveness evidence

7 A summary of the ERG's critique of the methods implemented by the company to identify
8 relevant health economic evidence is presented in Table 12 (cost-effectiveness evidence).

9 **Table 12. Summary of ERG's critique of the methods implemented by the company to**
10 **identify health economic evidence: cost-effectiveness**

Systematic review step	Section of CS in which methods are reported	ERG assessment of robustness of methods
Searches	Appendix G, Section G.1	Broadly appropriate.
Inclusion criteria	Appendix G, Section G.1	Studies that considered a non-lenalidomide maintenance treatment were excluded. Consequently, there is a possibility that relevant information may not have been identified via the search (e.g. costs and outcomes for a comparator arm). However, given that there is no established maintenance treatment for patients with NDMM, the ERG considers it unlikely that additional evidence would have been identified were the restriction on the intervention term relaxed
Screening	Appendix G, Section G.1	Appropriate.
Data extraction	NR	The ERG could not locate details of how data extraction was undertaken. While this omission is possibly less consequential given that interim data from only one trial were presented, the ERG considered that this undermined confidence in the accuracy of the characteristics of the key trials.
QA of included studies	NR	The ERG could not locate details of critical appraisal of included studies.

11 Key: CS, Company Submission; ERG, Evidence Review Group; HRQoL, health-related quality of life; NDMM, newly
12 diagnosed multiple myeloma; NR, not reported; QA, quality assessment

13

14 Overall, a total of four cost-effectiveness studies were identified. Each of the four cost-
15 effectiveness studies identified used a partitioned-survival analysis (PartSA) structure and
16 publicly-available trial data (CALGB 100104,^{3,4} GIMEMA⁷ and IFM 2005-02⁶) to estimate the

1 cost-effectiveness of maintenance compared with no maintenance in patients with newly
2 diagnosed MM in the pre-progression, post-progression and death health states.

3 Published cost-effectiveness analyses reported diverse estimates of the cost per QALY gained
4 for maintenance with lenalidomide. Key drivers of cost-effectiveness included: the clinical study
5 underpinning the analysis (CALGB 100104^{3,4} was the main source), using the list price for
6 lenalidomide, the duration of model time horizon and the mix of therapies used in subsequent
7 treatment lines in the model.

8 The company consider the identified economic evaluations were not fully aligned with the
9 decision problem for several reasons, including:

- 10 • None of the studies were evaluated from a UK payer perspective,
- 11 • There was notable heterogeneity in the clinical studies underpinning each economic
12 analysis (e.g. treatment dose; mixed ASCT and non-ASCT eligible populations and the use
13 of consolidation therapy),
- 14 • The use of subsequent therapies was not aligned with NICE recommendations, and
- 15 • The limited comparability of costs across the identified analyses

16 In addition, two analyses were not considered relevant as they evaluated maintenance
17 treatments (bortezomib and thalidomide) that are not licensed by the EMA for use in the UK
18 clinical setting. The model used to inform the current appraisal is discussed further in Section
19 4.2.2.

20 **4.1.2. Health-related quality of life and utilities**

21 A summary of the ERG's critique of the methods implemented by the company to identify
22 relevant health economic evidence is presented in Table 13 (health-related quality of life
23 [HRQoL] evidence).

1 **Table 13. Summary of ERG’s critique of the methods implemented by the company to**
 2 **identify health economic evidence: health-related quality of life**

Systematic review step	Section of CS in which methods are reported	ERG assessment of robustness of methods
Searches	Appendix H, Section H.1.1 & Section H.1.2	Broadly appropriate; however the ERG noted the bibliographic database searches were narrow in focus (combining terms for MM with terms for lenalidomide) and may have missed some relevant references.
Inclusion criteria	Appendix H, Section H.1.3	Broadly appropriate; however, the ERG noted that in restricting the population criterion to the maintenance population: “adults aged 18 years-plus with multiple myeloma who are eligible for ASCT and receiving maintenance treatment”, the company was unlikely to identify literature of relevance to the model. It appeared that this criterion was relaxed in screening to include studies in the broader population (see below).
Screening	Appendix H, Section H.1.3; and Appendix H p. 60-61; Appendix H, Section H2	<p>The ERG considered the approach to screening appropriate; i.e. two reviewers screening independently and involvement of a third reviewer to resolve discrepancies.</p> <p>Despite the specified population criterion, the ERG noted, however, that only three of the included studies (Abonour et al., 2016;¹⁴ Abonour et al., 2018;¹⁵ Boquoi et al., 2018¹⁶) were conducted in a maintenance population as specified in the PICOS (see Inclusion Criterion) above. It was not clear to the ERG at what stage of the screening process the population criterion was relaxed to include studies in the broader population and may have introduced selection bias.</p> <p>The ERG also highlighted a lack of clarity and a number of discrepancies in the company’s reporting of the study selection process for this review. While it was able to draw assumptions, it was not able to confirm whether these assumptions were correct (see below) and many discrepancies remained unresolved. As such the ERG had no confidence in the search outputs.</p> <p>The overall list of included publications in Table 30 (CS, Appendix H, Table 30) reconciled with the revised PRISMA (n=6).</p>
Data extraction	NR	The ERG could not locate details of how data extraction was undertaken.
QA of included studies	NR	The ERG could not locate details of critical appraisal of included studies.

3 Key: CS, Company Submission; ERG, Evidence Review Group; HRQoL, health-related quality of life; NDMM, newly
 4 diagnosed multiple myeloma; NR, not reported; PRISMA, Preferred reporting items for systematic review and
 5 metaanalysis; QA, quality assessment

6

1 In respect of the literature review to identify HRQoL and utility studies (CS, Appendix H), the
2 ERG highlighted a lack of clarity and a number of discrepancies in the company's reporting of
3 the study selection process for this review (Table 13, above). Although the company provided a
4 revised PRISMA flow diagram during clarification (Company response to B6), discrepancies
5 within the PRISMA remained (e.g. the PRISMA indicated 97 publications were excluded at full
6 text; however, 98 studies were in the revised list of excluded studies provided during clarification
7 (refer to Clarification Response, B5 & B6). This suggested that one study had not been
8 accounted for correctly in the documentation of the study selection process. Similarly, the
9 number of studies reported by reason for exclusion in the PRISMA also did not tally with the
10 revised list of excluded studies provided (Company response to B5 & B6.). In addition,
11 discrepancies between the PRISMA and accompanying text remained (e.g. Appendix H, p.60,
12 p.61 and p.67).

13 From the list of included studies, the company discussed Abonour et al. (2016),¹⁴ Acaster et al.
14 (2013),¹⁷ and Hatswell et al. (2019),¹⁸ (CS Appendix H, p.60). Two publications listed in Table
15 30 (Boquoi et al., 2018;¹⁶ and Roussel et al., 2018¹⁹) were not referenced by the company in its
16 discussion of the included evidence (CS Appendix H, p.60). In respect of Abonour et al.
17 (2016),¹⁴ the ERG also noted that the related full text publication (Abonour et al., 2018)¹⁵ was
18 listed as an included study in Table 30 (p.67) of the CS, yet the company did not refer to or cite
19 this publication in their discussion (Appendix H, p.60), and instead only cited the abstract
20 (Abonour et al., 2016¹⁴). The reason for this was not clear to the ERG. In addition, the company
21 referred to the meta-analysis conducted by Hatswell et al. (2019),¹⁸ but considered that the
22 heterogeneous population (eligible and non-eligible for ASCT) was not aligned with the scope of
23 the submission and instead scrutinised the bibliography for studies that met its eligibility criteria
24 specified in Table 29 of the CS (Appendix H, Table 29, p.66). The company reported (p.61) that
25 the studies by Acaster et al. (2013)¹⁷ and Tay et al. (2019)²⁰ had both been identified in this
26 way. The ERG noted, however, that Tay et al. (2019)²⁰ had not been cited by Hatswell et al.
27 (2019).¹⁸ On further scrutiny of the text the ERG considered it more likely that Tay et al. (2019)²⁰
28 had been identified via forward citation chasing of Abonour et al. (2016).¹⁴ However, as this was
29 not explicitly reported in the CS, the ERG was unable to confirm whether its assumptions were
30 correct. The study by Tay et al. (2019)²⁰ was subsequently excluded as it did not report
31 outcomes by health states relevant to the model.

32 The ERG agreed with the company's implied decision to discount the studies by Boquoi et al.
33 (2018)¹⁶ and Roussel et al. (2018),¹⁹ given that neither reported utility data for patients that had

1 relapsed beyond ASCT. In addition Boquoi et al. (2018)¹⁶ was only available as an abstract. The
 2 ERG noted that the study that specifically considered a maintenance population (Abonour et al.,
 3 2016; 2018),^{14,15} was not used to inform the economic model and considered this was also most
 4 likely due to a lack of available information for patients that had relapsed following ASCT.
 5 Instead, the model included the option to specify utility values reported by Acaster et al. (2013)¹⁷
 6 and Hatswell et al. (2019).¹⁸ Further information concerning the specification of model utility
 7 values is presented in Section 4.2.7.

8 4.1.3. Healthcare resource use and costs

9 A summary of the ERG’s critique of the methods implemented by the company to identify
 10 relevant health economic evidence is presented in Table 14 (healthcare resource use and cost).

11 **Table 14. Summary of ERG’s critique of the methods implemented by the company to**
 12 **identify health economic evidence: healthcare resource use and costs**

Systematic review step	Section of CS in which methods are reported	ERG assessment of robustness of methods
Searches	Appendix I, Section I.1	Appropriate.
Inclusion criteria	Appendix I, Section I.1	Appropriate.
Screening	Appendix I, Section I.1	Appropriate.
Data extraction	NR	The ERG could not locate details of how data extraction was undertaken.
QA of included studies	NR	The ERG could not locate details of critical appraisal of included studies.

13 Key: CS, Company Submission; ERG, Evidence Review Group; HRQoL, health-related quality of life; NDMM, newly
 14 diagnosed multiple myeloma; NR, not reported; QA, quality assessment

15
 16 Overall, a total of four published studies (Ashcroft et al., 2018;²¹ Jackson et al., 2017;²² Jackson
 17 et al., 2019;²³ Niphadkar et al., 2016²⁴). However, it is unclear to the ERG how these studies
 18 were considered in relation to the economic model. As none of the included studies feature in
 19 the reference list in Document B, it may be inferred that each of these studies were deemed by
 20 the company to not be suitable to inform the economic model.

21 The ERG noted with concern that the company’s systematic review of healthcare resource use
 22 and costs appears to have been ignored entirely in favour of using a combination of input from
 23 clinical experts, data from the Myeloma XI⁷ trial, and information reported in previously-
 24 published NICE technology appraisals. Healthcare resource use and costs are discussed in
 25 further detail in Section 4.2.8.

1 **4.2. Summary and critique of company's submitted economic evaluation by**
 2 **the ERG**

3 **4.2.1. NICE reference case checklist**

4 **Table 15: NICE reference case checklist**

Attribute	Reference case	ERG comment on company's submission
Perspective on outcomes	All direct health effects, whether for patients or, when relevant, carers	✓
Perspective on costs	NHS and PSS	✓
Type of economic evaluation	Cost-utility analysis with fully incremental analysis	✓
Time horizon	Long enough to reflect all important differences in costs or outcomes between the technologies being compared	✓ Time horizon of 40 years used. By the end of the modelled time horizon, >99.9% of patients on both treatment arms have died
Synthesis of evidence on health effects	Based on systematic review	✓ Systematic review undertaken to identify relevant evidence, though Myeloma XI trial deemed only relevant study to inform the economic model
Measuring and valuing health effects	Health effects should be expressed in QALYs. The EQ-5D is the preferred measure of health-related quality of life in adults.	✓ EQ-5D-3L utility values used to inform the model
Source of data for measurement of health-related quality of life	Reported directly by patients and/or carers	✓ Base-case analysis uses utility values based on a cross-sectional postal survey of 605 UK patients with MM
Source of preference data for valuation of changes in health-related quality of life	Representative sample of the UK population	✓ Based on UK value set for EQ-5D-3L
Equity considerations	An additional QALY has the same weight regardless of the other characteristics of the individuals receiving the health benefit	✓
Evidence on resource use and costs	Costs should relate to NHS and PSS resources and should be valued using the prices relevant to the NHS and PSS	✓ Though unclear how findings of literature review were incorporated into the model
Discounting	The same annual rate for both costs and health effects (currently 3.5%)	✓

5 Key: EQ-5D, EuroQol 5 dimension; HRQoL: health-related quality of life; NHS, National Health Service; PSS,
 6 Personal Social Services; QALY: quality-adjusted life year; TA: technology appraisal

1

2 4.2.2. Model structure

3 The structure of the company's economic model is presented in Figure 1. The model adopted a
4 partitioned survival analysis (PartSA, also known as an "area under the curve") structure, with
5 health state occupancy informed based on whether or not patients were alive (determined via
6 the OS curve) and if alive, whether or not patients had progressive disease (determined via the
7 PFS curve). Consequently, the model had three mutually-exclusive health states:

- 8 • Pre-progression: Patients that have yet to experience disease progression following ASCT
9 (with or without lenalidomide maintenance)
- 10 • Progressive disease: Patients that have experienced disease progression following ASCT
11 (with or without lenalidomide maintenance)
- 12 • Dead

13 An illustration of how health state occupancy was determined using the OS and PFS curves is
14 provided in Figure 2.

1 **Figure 1: Company model structure**

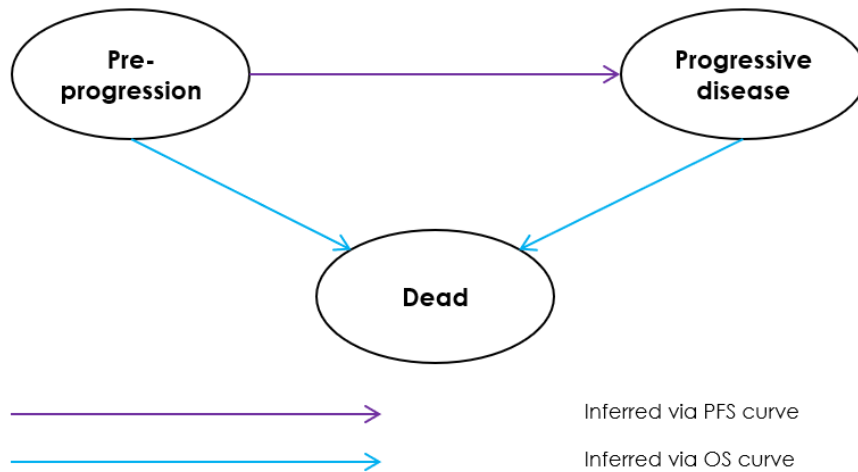

2

3 Key: OS, overall survival; PFS, progression-free survival.

4 Note: Diagram produced by the ERG

5

6 **Figure 2: Derivation of health state occupancy**

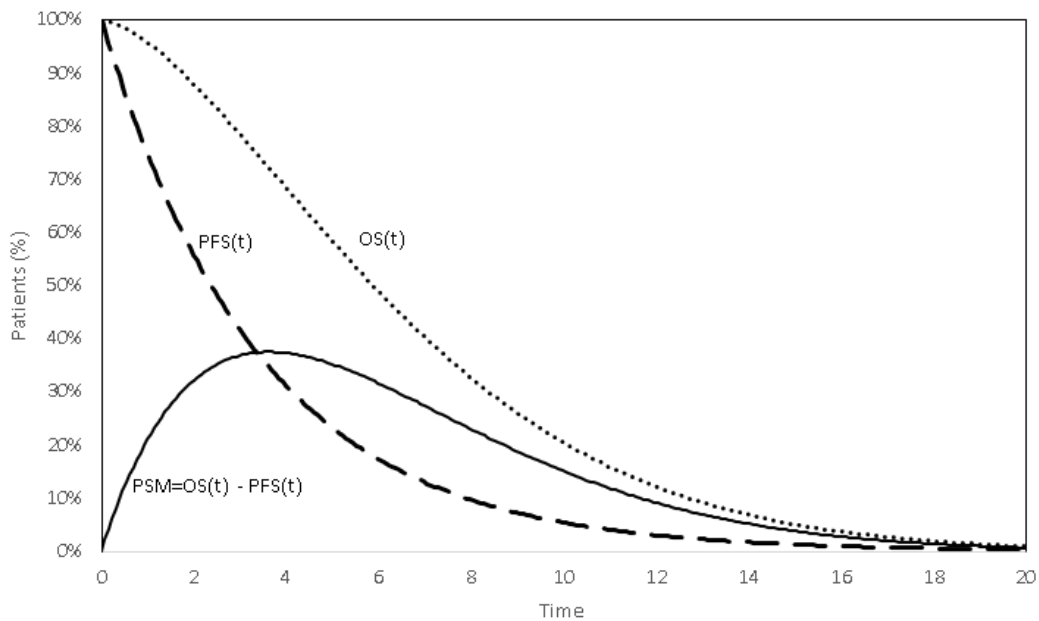

7

8 Key: OS, overall survival; PFS, progression-free survival; PSM, progressive disease state membership; t, time.

9 Source(s): Company submission, Document B, Section B.3.2.2, Figure 8

10

1 Separately to the estimation of health state occupancy, the company's model also uses a time-
2 to-treatment-discontinuation (TTD) curve to define the proportion of patients that are expected
3 to remain on maintenance treatment with lenalidomide over time. In Myeloma XI,⁷ patients
4 randomised to receive lenalidomide maintenance were expected to be treated until disease
5 progression or unacceptable toxicity. Therefore, the 'pre-progression' health state comprises a
6 combination of patients 'on' and 'off' treatment with lenalidomide maintenance.

7 Given that the model makes use of a 28-day cycle length, the company has half-cycle corrected
8 the estimated quality-adjusted life years (QALYs) and life years (LYs), though costs were not
9 half-cycle corrected. Lenalidomide maintenance treatment costs are expected to be incurred at
10 the start of each treatment cycle (in accordance with when packs of treatment are provided to
11 patients). The ERG noted that non-drug costs (i.e. medical resource use, AE, and end-of-life
12 care costs) should technically be half-cycle corrected (given that these costs may be incurred
13 part-way through a model cycle). However, it is unlikely that half-cycle correcting these costs
14 would have a large impact on results, and so the ERG considered the company's approach to
15 be reasonable.

16 As highlighted by the company within its submission, the model does not use transition
17 probabilities to describe transitions from one health state to the next – rather, transitions
18 between health states are inferred via the OS and PFS curves. This means that entry to the
19 progressed disease state per unit time (i.e. per model cycle) is not possible to establish within
20 this model structure, which has important implications for both the estimation of costs and
21 effects. However, at clarification stage the company provided further data from Myeloma XI
22 which demonstrated the majority of PFS events were progressions (Clarification B10). Health
23 state transitions are discussed in further detail in Section 4.2.6.

24 The company acknowledged at clarification stage that an alternative multi-state model (MSM)
25 structure could theoretically have been considered to explicitly model the transitions between
26 health states. The MSM structure was not chosen based on limited data to populate some
27 transitions (e.g. deaths occurring before progression), and that it would also "[require] *the*
28 *assumption that all post-progression deaths would be considered equal by arm given the lack of*
29 *demonstration of difference in post-progression deaths by arm*" (Clarification B7). The ERG
30 agreed that developing an MSM for this appraisal would be challenging in light of these potential
31 issues, but highlighted that PartSA and MSM approaches are not an exhaustive set of candidate
32 model structures to choose from.

1 Furthermore, the ERG did not agree that an absence of evidence—possibly better described as
2 ‘immature evidence’, given information provided during clarification—to support a difference in
3 post-progression survival automatically necessitates an assumption of no difference in post-
4 progression deaths between arms. The difference in post-progression survival between the
5 treatment arms may be due to differences in post-progression treatments received, or reflective
6 of the fact that delayed progression on the lenalidomide arm means that by the time patients
7 progress they are (on average) older and therefore have reduced life expectancy.

8 The ERG also noted that the company’s model considered all patients that have progressed
9 after ASCT (with or without lenalidomide maintenance) within a single ‘progressive disease’
10 health state. Based on clinical advice provided to the ERG, in practice some patients may be
11 treated with multiple lines of subsequent therapy for each successive relapse. Younger and fitter
12 patients in particular may be treated with several lines after relapse following ASCT, and could
13 plausibly receive more than five lines of successive treatment regimens (discussed further in
14 Section 4.2.8.4). The differences in costs incurred and outcomes accrued by patients at each
15 successive treatment line are therefore not captured within this structure, and so potentially
16 important differences in the modelled treatment arms may not be reflected by the model.

17 At clarification stage, the company explained that as the model encompasses several lines of
18 subsequent treatment with no further drops in utility, this may be considered a “*conservative*
19 *assumption as lenalidomide delays progression*” (Clarification B7). The ERG could not establish
20 the ‘true’ change in utility over time, given that subsequent lines are not explicitly modelled.
21 Given that lenalidomide is associated with survival benefits beyond disease progression, the
22 ERG also noted that any adjustments to utility values could have important effects on the ICER
23 in either direction (depending on the durations of subsequent therapies across each arm).

24 In addition, the beneficial effects of subsequent treatments were not captured separately to the
25 beneficial effects of lenalidomide maintenance within the company’s estimation of OS. Within its
26 submission, the company noted that the “*principal disadvantage*” of the PartSA model used is
27 that “*by assuming independence between OS and PFS, dependencies which may impact*
28 *extrapolation are not considered.*” (CS, Section B.3.9). Though this is certainly one limitation of
29 the modelling approach used, the ERG considered a much more important limitation to be
30 related to the potential impact of subsequent therapies – both in terms of costs and effects.
31 Through the estimation of an overarching OS curve, the impact of different assumptions relating
32 to the remainder of the treatment pathway on modelled QALYs cannot be established.

1 While the ERG agreed that the model captured the immediate after effects of ASCT ±
2 maintenance with lenalidomide, the ERG does not consider the company's model to provide an
3 entirely accurate reflection of the subsequent aspects of the treatment pathway in MM. By
4 extension, the ERG had several concerns regarding the suitability of using this model to inform
5 decision making, which predominantly relate to the capturing of subsequent therapy costs and
6 effects. The impact of subsequent therapies on outcomes are discussed further in Section 4.2.6.
7 Subsequent therapy costs are a key driver of cost-effectiveness results, and are discussed in
8 further detail within Section 4.2.8.

9 4.2.3. Population

10 The company's economic model considered the population specified in the final scope issued
11 by NICE (consistent with the marketing authorisation for lenalidomide): adult patients with
12 newly-diagnosed MM who have undergone an ASCT. As discussed in Section 3.2, this
13 population was not pre-specified in the Myeloma XI⁷ trial, but is aligned with the population
14 expected to be treated with lenalidomide maintenance in NHS practice.

15 4.2.4. Interventions and comparators

16 The intervention modelled is lenalidomide given as maintenance therapy following ASCT.
17 Lenalidomide monotherapy is dosed orally at 10mg per day, on Days 1-21 of a 28-day treatment
18 cycle. Treatment is administered until disease progression or death, and while the dose may be
19 escalated to 15 mg, clinical advice provided to both the company and the ERG indicated that
20 this was unlikely to occur in UK practice. However, some patients may experience a dose
21 reduction, and receive a dose of 5 mg per day on Days 1-21 of a 28-day treatment cycle.

22 At clarification, the ERG asked the company why the treatment regimen expected to be used in
23 NHS clinical practice (a 1–21 day regimen) is not aligned with the SmPC (a 1–28 day regimen).
24 The company clarified that clinical advice was sought to understand how lenalidomide would be
25 used in NHS practice. In Myeloma XI,⁷ the 1–21 day regimen was used because 1–21 day
26 regimens involving lenalidomide were the standard in non-ASCT eligible patients in NHS
27 practice, and the SmPC including the maintenance indication was not yet published. The
28 company also clarified that a 1–21 day regimen is expected to be better tolerated, as this
29 regimen is expected to be associated with a better safety profile and acknowledged *“the need to*
30 *give patients a rest for one week”* (Clarification A6).

1 The comparator to lenalidomide maintenance is “observation”, defined as established clinical
2 management without lenalidomide (for which no other active treatments are currently given in
3 NHS practice).

4 **4.2.5. Perspective, time horizon and discounting**

5 The company’s economic model adopted an NHS and PSS perspective on costs and outcomes.
6 A time horizon of 40 years was used, after which >99.9% of patients were estimated to have
7 died on both treatment arms. Costs and outcomes (QALYs and LYs) were discounted at 3.5%
8 per annum. The ERG is satisfied that the perspective, time horizon and discounting adopted by
9 the company’s model are aligned with the NICE reference case.

10 **4.2.6. Treatment effectiveness and extrapolation**

11 As described in Section 4.2.2, the company model used a PartSA structure, and so the effect of
12 lenalidomide is captured within the model through the estimation of OS and PFS curves.
13 Extrapolation of TTD were also included within the model, which is predominantly used to inform
14 drug costing and is discussed further in Section 4.2.8. Curves were fitted to data from Myeloma
15 XI,⁷ which was considered the most suitable study relevant to this appraisal.

16 At clarification stage, equivalent curve fits were provided based on the CALGB 100104^{3,4} study.
17 Provision of curves fits from this study allows for the consideration of an analysis based on the
18 licensed dose of lenalidomide maintenance (though clinical advice provided to the ERG noted
19 that this is not expected to reflect UK practice). Further information of the sensitivity analysis
20 using curves based on CALGB 100104^{3,4} is provided in Section 6.

21 The ERG highlighted that as the outcomes for each arm are captured by OS and PFS curves,
22 the contribution of treatments given after progression to the overall benefits of a given strategy
23 (i.e. maintenance or no maintenance) was unclear. This is especially challenging within the
24 context of the MM treatment landscape which has changed markedly in recent history, with
25 NICE having published 18 different MM technology recommendations since July 2011. Some of
26 these recommendations are (at the time of writing) based on availability only via the Cancer
27 Drugs Fund, and are therefore not considered part of established UK clinical practice, per
28 NICE’s position statement.²⁵ In addition, several recommendations issued by NICE have
29 conditions relating to which treatments should or should not be used in sequence.

30 In the CS, it is stated: “... *the mix of subsequent therapies observed in Myeloma XI ..., reflecting*
31 *clinical pathways in place when the trial was conducted, may no longer be representative of*

1 *currently and future subsequent treatments, resulting in unrealistic and potentially inaccurate*
2 *estimation of costs of care displaced by the introduction of maintenance in the multiple myeloma*
3 *pathway.”* (CS, Section B.3.4.4). While true, the same commentary applies to outcomes
4 associated with subsequent therapies, given the general expectation that modern clinical
5 practice is expected to have improved outcomes compared to historical practice. Subsequent
6 therapies are also important to consider within the context of costs, which are discussed in
7 further detail within Section 4.2.8.4.

8 Within its report, the ERG has focused on the likely directional effect on the ICER associated
9 with a changeable treatment pathway after relapse following lenalidomide maintenance versus
10 observation. However, owing to the aforementioned complexities involved with funding and
11 treatment sequencing, this is an unavoidably multifaceted issue, which cannot be easily
12 resolved with available data and using the company’s PartSA model. A range of sensitivity
13 analyses are presented within Section 6 as a means of illustrating the potential impact of
14 varying assumptions relating to the costs and benefits of subsequent therapy.

15 4.2.6.1. Overall survival

16 To extrapolate OS from the Myeloma XI⁷ trial, the company fitted a range of parametric survival
17 models. Models were fitted independently (i.e. separate models fitted to each treatment arm) or
18 with a covariate for treatment arm (a “joint” model). The CS noted that model selection was
19 based on “*internal validity (log-hazard plots, Q-Q plots, goodness of fit to the observed data*
20 *using AIC and BIC) and external validity (clinical plausibility of the extrapolations)”*, following
21 guidance from NICE Decision Support Unit (DSU) Technical Support Document (TSD) 14.²⁶ The
22 company provided additional evidence of testing the proportional hazards (PH) assumption in
23 response to a clarification question, including provision of a Schoenfeld residual plot
24 (Clarification A14).

25 Six parametric forms were considered: exponential, Weibull, Gompertz, lognormal, log-logistic,
26 and generalised gamma; which (given each parametric form was fitted independently or jointly)
27 yielded a total of 12 distinct curves to inform the estimation of OS for each modelled treatment
28 arm. To ensure the modelled hazard of death per model cycle did not fall below the value for the
29 age- and sex-adjusted general population, the company used published general population
30 mortality statistics to adjust long-term extrapolations.

31 The company stated that while both independent and joint models were fitted, the joint models
32 “... *largely deviated from the lenalidomide KM, generating unsatisfactory approximations of both*

1 *curves at the same time and therefore unsuitable for valid extrapolation*" (CS, Section
2 B.3.2.5.2). Consequently, the company opted to use independent models for OS, and did not
3 provide statistical goodness-of-fit scores for the joint models.

4 In the company's base-case analysis, a log-logistic model was selected for the lenalidomide
5 arm, and a Weibull model was selected for the observation arm. These projections are
6 presented in Figure 3.

7 **Figure 3: Company base-case projections of overall survival**

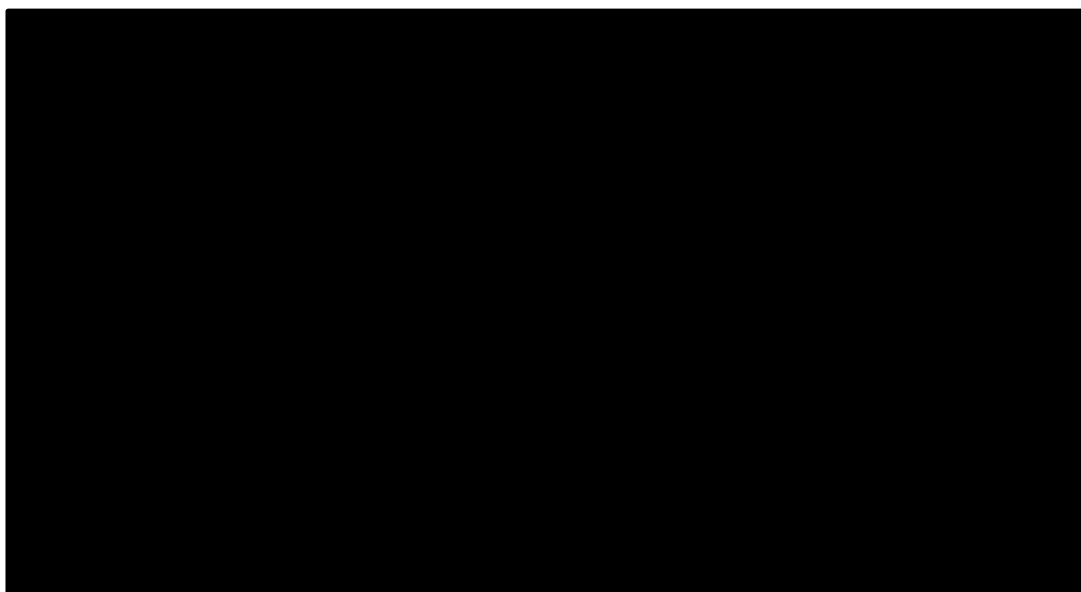

8

9 Key: LEN, lenalidomide maintenance; OBS, observation.

10 Note: Plot produced by the ERG.

11

12 On the lenalidomide arm, median OS is estimated to be approximately [REDACTED], compared with
13 the observation arm where this is estimated to be [REDACTED]. Notably, on the observation arm
14 nearly all patients were estimated to have died by approximately [REDACTED] (99% of patients have
15 died by this time) compared to approximately [REDACTED] of patients still being alive on the lenalidomide
16 maintenance arm at this point in time.

17 The ERG did not consider the use of independent models for OS using two different functional
18 forms to be fully justified based on the available data from Myeloma XI.⁷ Evidence provided by
19 company showed that within the observed period of Myeloma XI,⁷ both the PH and constant AF
20 assumptions may be reasonably made (based on the log-cumulative hazard and Q-Q plots, CS

1 Figure 10). This implied a similar pattern of survival was seen across both treatment arms,
2 which could theoretically be explained via the specification of a covariate for treatment
3 assignment.

4 The similarity in survival within the observed period may be inferred via Figure 4, which shows
5 independent model fits using both a log-logistic and Weibull functional form for both arms which
6 are near-identical up until approximately five years. However, in the longer-term, the estimates
7 of OS diverge greatly between the different models, with the log-logistic models providing much
8 greater estimates. Importantly, the independent model fits using the same functional form
9 demonstrate similar patterns of survival across both treatment arms, without compromising fit to
10 the Kaplan-Meier curves.

11 **Figure 4: Comparison of independent log-logistic and Weibull projections of overall**
12 **survival**



13

14 Key: LEN, lenalidomide maintenance; OBS, observation.

15 Note: Plot produced by the ERG.

16

17 To explore the difference in OS models further, the estimated hazard of death per model cycle
18 was produced using the following formula:

19

$$\tilde{h}(t) = \lim_{dt \rightarrow 0} \frac{P(t \leq T < t + dt | T \geq t)}{dt} \approx 1 - \frac{S(\text{cycle} + 1)}{S(\text{cycle})}$$

1 Using this formula, it was possible to estimate the calculated probability of death per model
2 cycle for each treatment arm, and use this information to elicit the estimated ratio between these
3 values – analogous to an implied (estimated) HR between the treatment arms. The results of
4 this analysis are presented in Figure 5, which shows the implied HR between five
5 ([REDACTED]) and 20 years.

6 [REDACTED]
7 [REDACTED]
8 [REDACTED]

9 **Figure 5: Implied hazard ratio in company's base-case analysis**

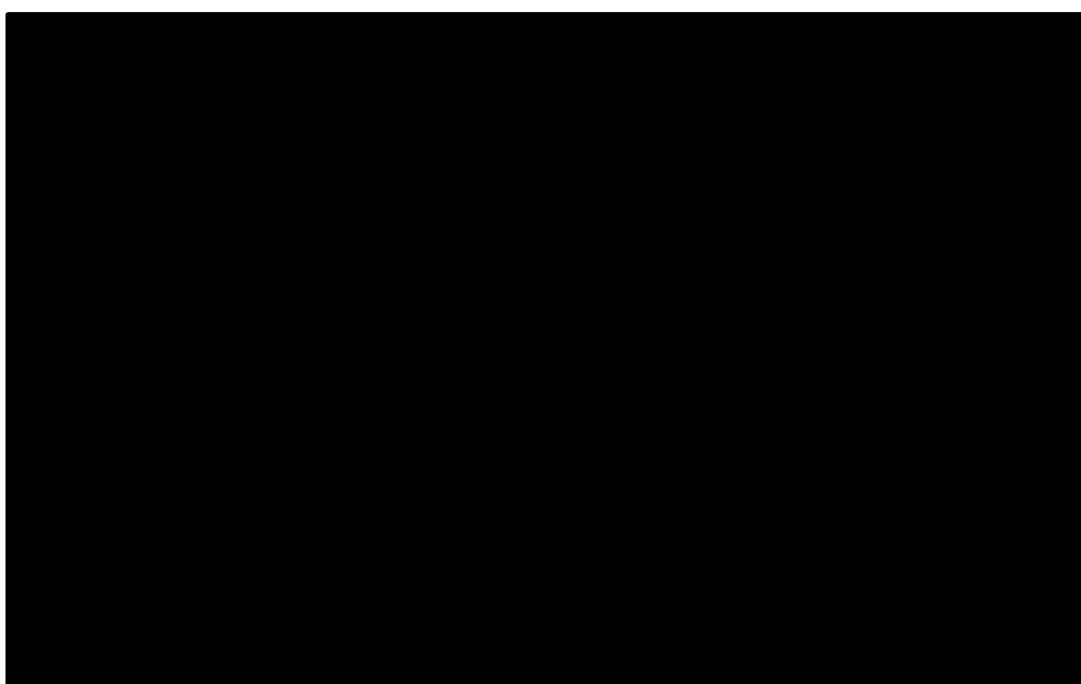

10

11 Key: LEN, lenalidomide maintenance; OBS, observation.

12 Note: Plot produced by the ERG.

13

14 Within the model structure provided by the company, it was not possible to enable or disable the
15 specific effects of subsequent treatments on OS. Therefore, it was not possible to fully establish
16 how future estimates of OS may be impacted by specific subsequent
17 therapies [REDACTED]

18 [REDACTED]. The ERG considered an
19 important omission from the CS is a detailed explanation as to how longer-term survival may be

1 influenced by subsequent therapies, and how this was factored into the determination of
2 appropriate survival models for the outcome of OS across both treatment arms.

3 [REDACTED]
4 [REDACTED]
5 [REDACTED]

6 The ERG noted that the company also provided evidence from the CALGB 100104^{3,4} study to
7 inform model selection. While these data may be helpful in terms of understanding how the
8 pattern of survival may change over time, they are subject to a number of important limitations:

- 9 • None of the patients enrolled in CALGB 100104^{3,4} were from the UK, and all patients were
10 treated with the licensed dosing regimen of 10 mg on Days 1–28 of a 28-day treatment
11 cycle.
 - 12 – The overall duration of treatment with lenalidomide maintenance was [REDACTED] in
13 CALGB 100104^{3,4} versus Myeloma XI⁷ (CS Figure 20), which may therefore impact
14 estimates of OS (if indeed a dose-response relationship is expected).
- 15 • Estimates of OS for the observation arm were confounded by treatment switching.
 - 16 – Consequently, OS for the observation arm was adjusted using RPSFTM. Therefore,
17 additional uncertainty is introduced within the estimation of OS for the observation
18 arm in particular.
- 19 • The impact of differences in baseline characteristics on overall prognosis (and potentially
20 treatment effect) was unclear.
 - 21 – For example, in CALGB 100104^{3,4} approximately 2% of patients had an international
22 staging system (ISS) score at baseline of III versus approximately 20% of patients in
23 Myeloma XI.⁷ ISS is a recognised staging system which is (by definition) highly
24 correlated with prognosis.
- 25 • The impact of subsequent treatments is unclear.
 - 26 – As with the Myeloma XI⁷ study, the impact of subsequent treatments was not
27 explicitly captured within the estimation of OS curves. As such, given that CALGB

1 100104^{3,4} was carried out internationally, the generalisability of the treatment
2 pathway after relapse (and its impact on estimated outcomes) remains unclear.

3 • There is some (limited) evidence of a potentially-important difference in post-progression
4 survival seen in Myeloma XI⁷ versus CALGB 100104.^{3,4}

5 – In Myeloma XI,⁷ median post-progression survival for the lenalidomide arm was ■
6 months (versus ■ months for observation). Conversely, in CALGB 100104 the
7 equivalent estimates were 42.6 (lenalidomide) versus 39.2 (observation) months.³ As
8 described in Section 3.2.3.1, interpretation of post-progression survival requires
9 considerable caution, yet this difference between the studies may have an important
10 effect on OS.

11 Consequently, the ERG emphasised caution when considering CALGB 100104^{3,4} as an external
12 data source to aid model selection. In its submission, the company stated: “OS curves in
13 CALGB [100104] appear to separate further over longer follow up, suggesting that the PH
14 assumption may not hold in the longer term, although this hypothesis cannot be challenged with
15 Myeloma XI data.” (CS, Section B.3.2.5.2). The company did not provide evidence to support
16 the rejection of the PH assumption from CALGB 100104,^{3,4} and so the ERG has produced a log-
17 cumulative hazard plot to explore this based on data provided in the company’s economic
18 model (Figure 6). Based on this plot, the ERG did not agree with the company’s suggestion that
19 the PH assumption does not hold based on data from CALGB 100104 – moreover, the evidence
20 of the PH assumption is arguably stronger from CALGB 100104^{3,4} versus Myeloma XI⁷ (given
21 the additional follow-up available from this study).

1 **Figure 6: Log-cumulative hazard plot (OS from CALGB 100104)**

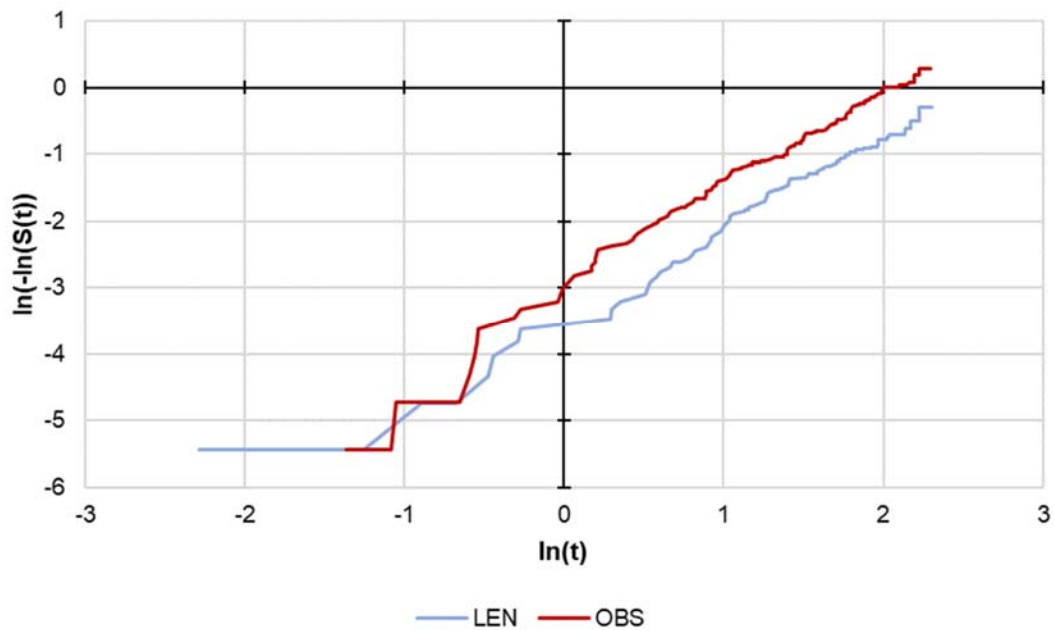

2

3 Key: LEN, lenalidomide maintenance; OBS, observation; $S(t)$, survival at time t .

4 Note: Plot produced by the ERG.

5

6 For completeness, the ERG also produced the corresponding Q-Q plot to assess the constant
7 AF assumption (Figure 7). This plot exhibited a linear pattern, indicating that a model based on
8 the constant AF assumption may be suitable.

1 **Figure 7: Q-Q plot (OS from CALGB 100104)**

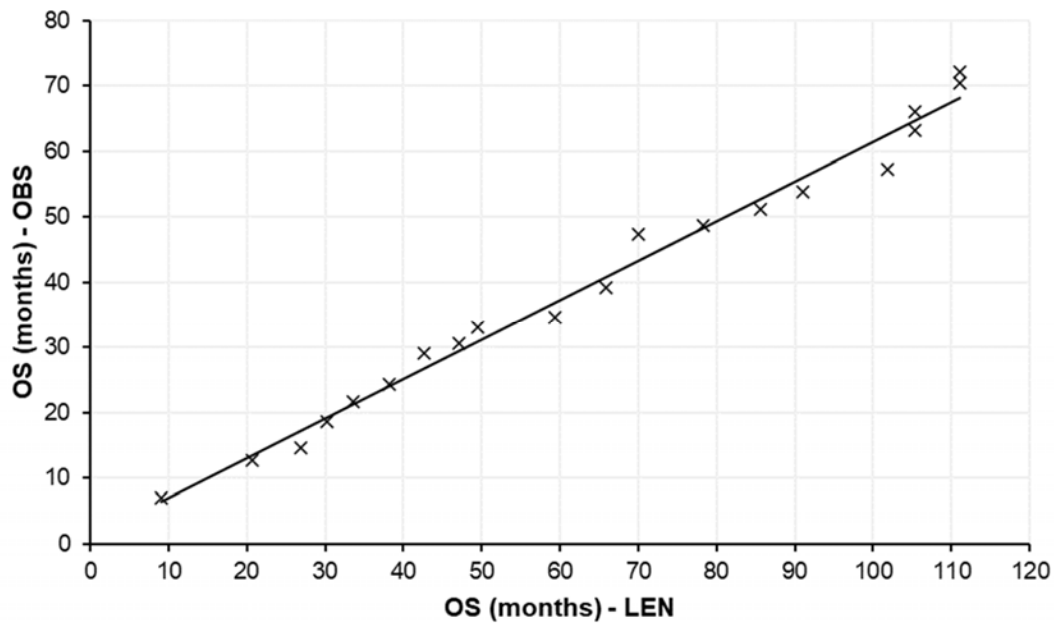

2

3 Key: LEN, lenalidomide maintenance; OBS, observation; OS, overall survival.

4 Note: Plot produced by the ERG.

5

6 The ERG preferred the use of a joint log-logistic model to inform its preferred base-case
7 analysis (Figure 8). For the lenalidomide arm, this results in a very similar projection to that used
8 in the company's base-case analysis. However, for the observation arm OS is increased when
9 using the joint log-logistic approach (versus the company's independent Weibull approach).

1 **Figure 8: ERG's preferred extrapolation of OS**

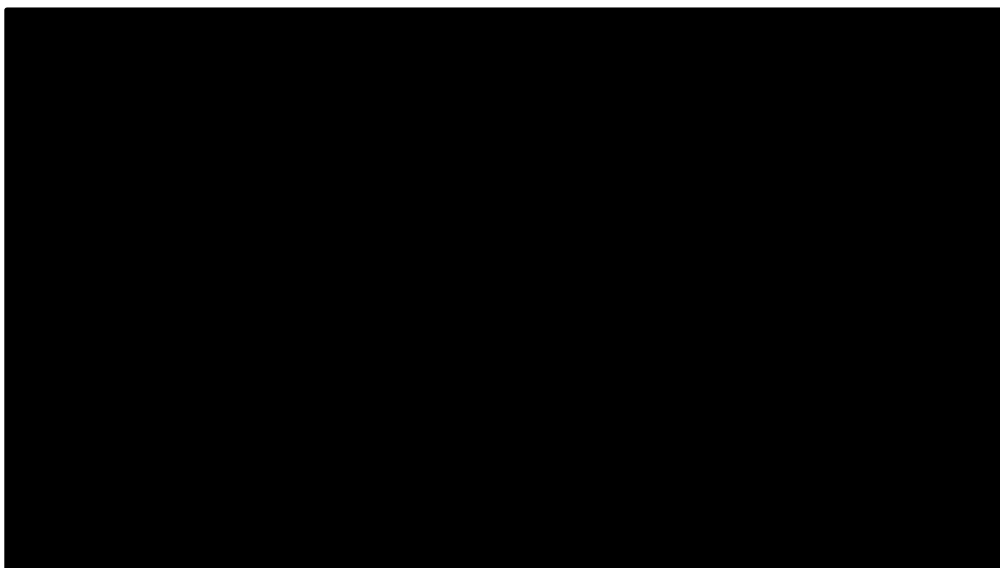

2

3 Key: LEN, lenalidomide maintenance; OBS, observation.

4 Note: Plot produced by the ERG.

5

6 According to CRUK statistics,²⁷ approximately one-third of patients survive until 10 years or
7 more following a diagnosis of multiple myeloma. While this reflects the totality of the MM
8 population (of which approximately 70–75% are typically deemed transplant ineligible [CS,
9 Section B.1.3.3]), the ERG noted it is therefore plausible for a substantial proportion of patients
10 who undergo an ASCT to survive for longer than 10 years, even without lenalidomide
11 maintenance. Equivalently, because of the limited information available concerning 10-year
12 survival, the 'true' value may potentially be lower, given that most patients are diagnosed at
13 around 60–70 years of age.

14 Clinical advice provided to the ERG noted that 10-year survival for patients that have undergone
15 ASCT, treated with or without lenalidomide maintenance, would be expected to be higher than
16 the whole multiple myeloma population; owing to the better prognosis of ASCT-eligible versus
17 ASCT-ineligible patients. The specification of a joint log-logistic model yielded an estimated 10-
18 year OS for the observation arm of [REDACTED], compared with [REDACTED] in the company's base-case
19 analysis.

20 [REDACTED]

21 [REDACTED]

1 [REDACTED]

2 [REDACTED]

3 The ERG also noted the importance of considering other models when determining the most
4 plausible estimate of long-term survival for both treatment arms. A joint Weibull model may also
5 be credible, given the evidence of PH from both Myeloma XI⁷ and CALGB 100104^{3,4}

6 ([REDACTED])

7 [REDACTED]). As noted previously, the company did not provide statistical goodness-of-fit scores for the
8 joint models fitted to OS within its submission, and so the relative statistical fit for the different
9 joint models cannot be established. Furthermore, the company did not present the results of
10 alternative survival models as part of its suite of sensitivity analyses. Therefore, alternative
11 specifications of OS are explored within sensitivity analyses conducted by the ERG.

12 Importantly, while evidence in support of a constant treatment effect is available based on the
13 observed period of data collection from Myeloma XI⁷ and CALGB 100104,^{3,4} there is relatively
14 little evidence available to support the expectation of a continued treatment effect (whether that
15 is constant or consistently improving) for the remainder of the model time horizon. It may
16 therefore also be appropriate to consider sensitivity analyses including a potential treatment
17 waning effect. This is explored further within the ERG's exploratory analyses (Section 6.1.1).

18 4.2.6.2. Progression-free survival

19 The company adopted a similar approach to estimating PFS as per the approach taken to
20 estimate OS (see Section 4.2.6.1 for further details). The company provided statistical
21 goodness-of-fit scores for both independent and joint models, commenting that the scores were
22 similar across all models except for the lognormal model which appeared to provide a "poor fit"
23 to the Myeloma XI⁷ data (CS Table 22).

24 The visual fit of the models was also compared, and the company noted that "*joint models fit the*
25 *lenalidomide and observation arms reasonably well*" (CS, Section B.3.2.5.1), and so these
26 models were considered henceforth. The ERG agreed that there does not appear to be any
27 clear evidence to justify the need for an independent modelling approach to model PFS.

28 The company highlighted that while no model appears to provide a poor fit to the lenalidomide
29 Kaplan-Meier curve, the exponential and lognormal models provide a poorer fit to the
30 observation Kaplan-Meier curve. The ERG agreed that both the lognormal and exponential
31 models do not provide a good visual fit to the observation Kaplan-Meier curve, as may be seen

1 in Figure 9. Notably, the exponential model does not fit the earliest portion of the curve (up until
2 approximately 1.5 years) or the latter portion of the curve (after three years) particularly well
3 compared with most of the other models (CS Figure 11).

4 **Figure 9: Comparison of exponential and log-logistic models for PFS**

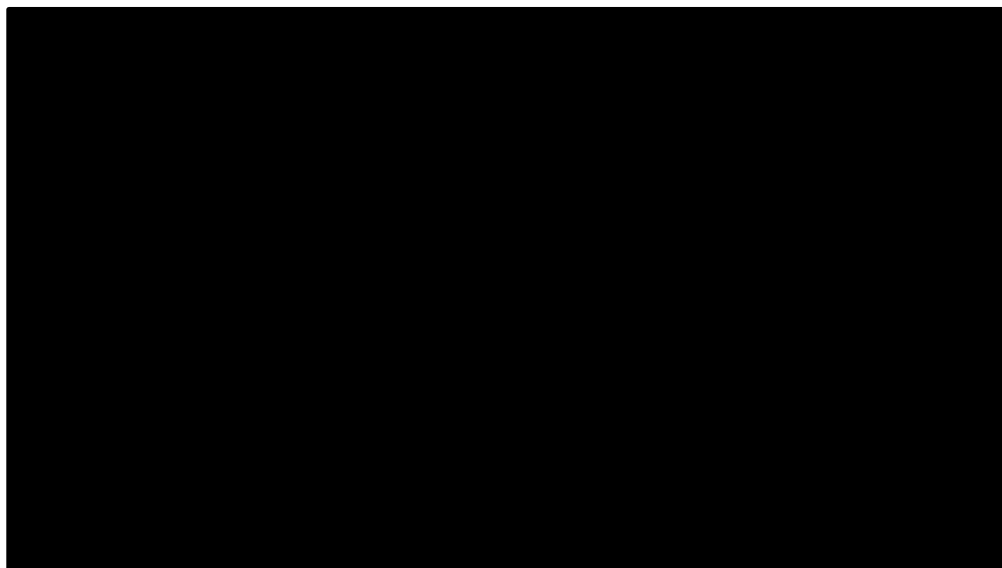

5

6 Note: Plot produced by the ERG.

7

8 As with the outcome of OS, the company referenced data from CALGB 100104^{3,4} to support the
9 selection of an appropriate model for PFS. Using these data, the company stated a preference
10 for either an exponential or log-logistic modelling approach (based on visual fit to the CALGB
11 100104 Kaplan-Meier curve), and ultimately informed its base-case analysis using an
12 exponential model. The exponential model was chosen in favour of the log-logistic model as the
13 log-logistic was deemed to yield *“optimistic estimates for PFS, predicting that 5% of untreated*
14 *patients would remain in pre-progression at 20 years”* (CS, Section B.3.2.5.1).

15 The ERG agreed with the use of a joint modelling approach for the outcome of PFS, but does
16 not agree with the company’s choice of an exponential model. As described in Section 4.2.6.1,
17 the ERG had a number of concerns relating to the CALGB 100104^{3,4} study and therefore did not
18 consider this an appropriate means of informing model selection unless a model provided
19 substantially different estimates of longer-term PFS. Moreover, the ERG does not agree with the
20 specification of a model that clearly provides a poorer visual fit to the trial data from which it was

1 estimated and a notably poor statistical fit (see CS, Section B.3.2.5.1. Table 22) simply because
2 it provides an estimate more aligned with an external data source.

3 With the above in mind, the ERG preferred the use of a Weibull model for PFS, based on
4 statistical goodness-of-fit (as it is the best-fitting model, measured by both Akaike information
5 criterion [AIC] and Bayesian information criterion [BIC]), provides a good visual fit to both arms
6 of Myeloma XI,⁷ and does not yield substantially dissimilar longer-term estimates of PFS
7 compared with the other models. The ERG's preferred base-case PFS model is presented in
8 Figure 10.

9 **Figure 10: ERG's preferred extrapolation of PFS**

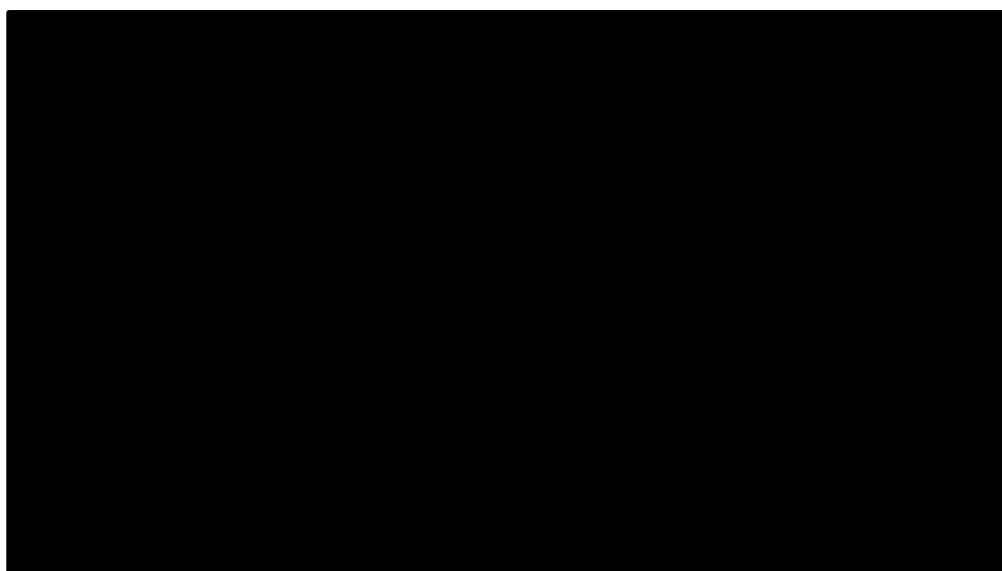

10

11 Key: LEN, lenalidomide maintenance; OBS, observation.

12 Note: Plot produced by the ERG.

13

14 As with OS, the ERG considered it appropriate to consider a range of alternative
15 parameterisations for PFS (given that the company provided evidence to support the use of
16 either a PH or an AFT model). Sensitivity analyses conducted by the ERG are discussed further
17 in Section 6.1.3.

1 4.2.7. Health-related quality of life

2 4.2.7.1. Health state utility values

3 No HRQoL data were available from the four main studies identified by the company (Myeloma
4 XI,⁷ CALGB 100104,^{3,4} GIMEMA,⁵ and IFM 2005-02⁶). To inform the economic model, utility
5 values were sought from the published literature (Section 4.1.2). In the company's base-case
6 analysis, values taken from Acaster et al., 2013¹⁷ were used to inform the model. This study
7 reported the findings of a cross-sectional postal survey of 605 UK patients with MM, categorised
8 by the following:

- 9 • **First-line:** First-line treatment was described as the first treatment received to treat
10 myeloma. If the patient had changed treatments due to unresponsiveness or side effects,
11 these additional treatments still counted as 'first line'
- 12 • **Second-line:** Second-line treatment was described as the treatment received after the first
13 relapse, which may be a repeat of the first-line treatment if the response had been good or
14 an alternative treatment.
- 15 • **First treatment-free interval (TFI):** The first TFI was described as the first time a patient is
16 classed as being in remission; the patient may be taking supportive treatments (e.g.
17 painkillers or anaemia medication) but is not receiving any active myeloma or maintenance
18 treatment during this time
- 19 • **Later stage:** Later stage was described as the time from second remission onwards.

20 The model assumed the average utility for patients residing in the 'pre-progression' state was
21 equivalent to the utility score for the first TFI (0.72). This assumption was based on the
22 expectation that this state reflects the utility of patients on the observation arm, and that there
23 was no expected difference in utility by treatment arm (except relating to the occurrence of
24 adverse events). The utility value for the 'progressive disease' state was assumed to be
25 equivalent to the second-line value (0.67).

26 As a scenario analysis, the model also included the option to use utility values from Hatswell et
27 al., (2019).¹⁸ The utility value for the 'pre-progression' state was assumed to be equivalent to the
28 value reported for patients that have received one treatment class (0.62), and the value for the
29 'progressed disease' state was assumed to be equivalent to value reported for patients that
30 have received two treatment classes (0.57).

1 At clarification stage, the company provided an explanation for its preference for the utility
 2 values from Acaster et al., (2013)¹⁷ versus those from Hatswell et al., (2019).¹⁸ The company
 3 clarified that the study by Hatswell et al. (2019)¹⁸ reported the findings of a meta-analysis of
 4 published studies (including Acaster et al., [2013]¹⁷) from a non-homogeneous patient
 5 population, including patients that were eligible and ineligible for ASCT (Clarification B15).

6 Upon further inspection of the meta-analysis by Hatswell et al., (2019),¹⁸ it can be seen that the
 7 utility values were grouped according to the number of treatment classes received. This meant
 8 that the values from Acaster et al., (2013)¹⁷ for ‘first line’ and ‘first TFI’ were grouped together in
 9 the overall meta-analysis conducted, which was noted by the authors of this study to be a
 10 simplification due to a range of definitions used to define treatment lines in published studies.

11 The ERG agreed with the company’s decision to use utility values from the study by Acaster et
 12 al., (2013)¹⁷ in favour of those reported within the Hatswell et al., (2019)¹⁸ meta-analysis, given
 13 that the approach taken to meta-analysing utility values in the latter study does not lend itself to
 14 providing utility scores that correspond to a maintenance population. In spite of the limitations of
 15 the Hatswell et al., (2019)¹⁸ analysis, this study provides an alternative set of utility values that
 16 may be considered within sensitivity analysis. A summary of the utility values available to inform
 17 the model are presented in Table 16.

18 **Table 16: Utility values (not adjusted for age or adverse events) used in model**

Health state	Acaster et al., (2013)*	Hatswell et al., (2019)
Pre-progression	0.72	0.62
Progressive disease	0.67	0.57

19 Note: *Company base-case.
 20

21 **4.2.7.2. Adjustments to utility values**

22 To account for differences in utility as patients age, the model applies a utility multiplier based
 23 on England general population norms.²⁸ The ERG considers it appropriate to factor in
 24 adjustments to utility over time, given that some patients are projected to live for well over 20
 25 years. However, the patient population considered in the study by Acaster et al. (2013)¹⁷ were
 26 slightly older on average (mean age of 63.6 and 64.0 years based on the two health states used
 27 to inform the model) versus the Myeloma XI⁷ population (average age of ██████ based on the
 28 economic model). Therefore, age-related effects on utility may be slightly over-estimated in the
 29 company’s model. The ERG has conducted an additional analysis to ‘delay’ the effect of age-

1 related declines in utility by approximately five years. The impact of this analysis on the cost-
2 effectiveness results is presented in Section 6.1.3.

3 In addition to age-related effects, the impact of AEs on utility was also captured by the model
4 (for the lenalidomide arm), calculated from the rate of AEs in Myeloma XI,⁷ multiplied by the
5 utility weight and adjusted for the duration of each AE. AEs were included if they were Grade III
6 or above and occurred in at least 2% of patients treated with lenalidomide in Myeloma XI. The
7 ERG considered this a suitable cut-off for including clinically-relevant side effects with an
8 important impact on patient utility. Disutilities and durations relating the occurrence of AEs were
9 taken from NICE TA510,²⁹ which the ERG considered reasonable.

10 The rate of AEs per model cycle was calculated based on the number of individuals reporting
11 each AE in the lenalidomide arm, over the median duration of follow-up in Myeloma XI.⁷ The
12 median duration of follow-up in Myeloma XI was reported to be 31 months, though it should be
13 noted that this is not the same as the median duration of treatment for the subgroup relevant to
14 this appraisal [REDACTED]. A more accurate
15 estimation of the rate of AE occurrence would ideally be based upon the duration of treatment
16 exposure, rather than follow-up (as the latter includes patients that are no longer receiving
17 treatment). Nevertheless, as the proportion of patients that experienced Grade III or above AEs
18 is relatively low, the impact of alternative approaches to estimating rates of AE occurrence is
19 unlikely to be a large driver of cost-effectiveness results.

20 **4.2.8. Resources and costs**

21 The company's model included costs relating to lenalidomide maintenance, medical resource
22 use (follow-up and monitoring), the resolution of AEs, and post-progression therapy costs. The
23 costs are discussed in turn below.

24 **4.2.8.1. Lenalidomide maintenance**

25 As described in Section 4.2.4, maintenance with lenalidomide is anticipated to be dosed as
26 monotherapy at 10 mg per day, on Days **1–21** of a 28-day treatment cycle. This dosing regimen
27 is not aligned with the licensed dosing regimen (10 mg per day, on Days **1–28** of a 28-day
28 treatment cycle). Clinical advice to the ERG suggests that the 21-day regimen would be used in
29 NHS practice (in accordance with how lenalidomide is used in other indications, as well as
30 accounting for the availability of lenalidomide in the UK).

1 The SmPC¹¹ noted that the dose of lenalidomide should not be any lower than 5 mg given on
2 Days 1–21 of a 28-day treatment cycle, but that the dose can be increased to 15 mg orally once
3 daily if tolerated. At clarification, the ERG asked the company to comment on the possibility of
4 dosing increases in practice. In response, the company explained that no patients in Myeloma
5 XI had an increase in dose to 15 mg, and that the trial protocol did not mention the possibility of
6 increasing the dose in this way (Clarification A7).

7 According to the British National Formulary,³⁰ in the UK lenalidomide is available in packs of 21
8 capsules at doses of 2.5mg, 5mg, 7.5mg, 10mg, 15mg, 20 mg, and 25 mg. The list prices of
9 packs of lenalidomide that are potentially relevant to this appraisal are presented in Table 17

10 **Table 17: List price of lenalidomide**

Dose (pack of 21 capsules)	List price
5 mg	£3,570.00
7.5 mg	£3,675.00
10 mg	£3,780.00
15 mg	£3,969.00

11 Key: mg, milligram(s).

12 Note: Lenalidomide is also available in doses of 2.5mg, 20mg, and 25mg (not presented here for brevity).

13 Source: British National Formulary³⁰ website.

14

15 It can be seen from Table 17 that the cost-per-mg of lenalidomide varies depending on the dose
16 required (i.e. lenalidomide packs are not priced linearly in relation to the dose in each pack). In
17 addition, lenalidomide is available only in packs of 21 capsules.

18 At the time of writing, a commercially-sensitive, simple patient access scheme (PAS) agreement
19 is in place for lenalidomide. This discount is equivalent to a discount of [REDACTED] on the list price of
20 lenalidomide. [REDACTED]

21 [REDACTED]

22 [REDACTED]

23 [REDACTED]

24 [REDACTED]

25 [REDACTED]

26 [REDACTED]

1 [REDACTED]

2 [REDACTED]

3 In the CS, it is explained that the dose of 10mg per day was adjusted to account for relative
4 dose intensity (RDI) to “ensure consistency with outcomes data” (CS, Section B.3.2.7). At
5 clarification stage, the ERG asked the company to clarify why the adjustment to dose using RDI
6 accounts appropriately for wastage costs. In response, the company stated: “Myeloma XI data
7 included overall dose intensity for each patient, calculated as a derived variable by trial
8 investigators. This was used for the calculation of RDI” (Clarification A10). Based on this
9 explanation, the ERG still considers it unclear how RDI accounts for wastage.

10 The generally-accepted definition of RDI is the ratio of planned and delivered doses of a given
11 treatment. In response to clarification question A7, the company confirmed that RDI was
12 estimated based on the proportion of average dose / recommended dose of lenalidomide. The
13 difference between the planned and delivered dose could be due to a number of reasons,
14 including (but not limited to): dose modifications, lack of adherence, or delayed doses. At
15 clarification stage, the company noted that approximately [REDACTED] of patients in Myeloma XI had a
16 dose reduction (Clarification A11), yet the proportions of patients that missed or had delayed
17 doses is unclear.

18 Furthermore, it remained unclear to the ERG why the RDI estimate from Myeloma XI ([REDACTED]) is
19 noticeably smaller than the estimate of RDI from the TMM1 clinical trial (in the relapsed/
20 refractory MM population) of 94.9%, given that patients in Myeloma XI⁷ received a lower target
21 dose (10 mg versus 25 mg daily on Days 1–21, repeating every 28-day cycle). As
22 acknowledged previously, the company explained at clarification stage that a 1-21 day regimen
23 is expected to be better tolerated compared to a 1-28 day regimen, owing to the expectation of
24 a better safety profile (Clarification A6).

25 Clinical advice provided to the ERG clarified that the lower dose of 10 mg for lenalidomide given
26 as maintenance therapy was purposefully lower than the dose of 25 mg given after relapse as
27 the intention of maintenance treatment is for it to be administered for as long as possible (i.e.
28 until relapse or unacceptable levels of toxicity). The ERG therefore considered it reasonable to
29 expect that a lower overall exposure to lenalidomide (achieved either through a lower daily dose
30 or by including a treatment break within the dosing regimen) would lead to fewer treatment-
31 related AEs, and therefore patients would be more likely to maintain the target dose.

1 As the estimation of RDI remained unclear, the ERG considered it most appropriate to not use
2 the RDI estimate from Myeloma XI⁷ as a proxy for proportion of 10 mg packs provided to
3 patients. This is especially important to consider within the context of the economic model, given
4 that RDI is applied using methodology akin to a flat discount on the cost of acquisition (i.e. the
5 cost per pack is multiplied by one – RDI in the model).

6 In the ERG's base-case analysis, the RDI for lenalidomide maintenance was set to 94.9% for
7 consistency with the TMM1 clinical trial and to reflect the fact that any dose reductions from
8 10 mg to 5 mg are not associated with a 50% reduction in costs (as this would instead be
9 equivalent to a ~5.6% reduction in costs). However, the ERG noted that because the full
10 implications of RDI on the costing of lenalidomide within the model remained unclear, it may
11 also be reasonable to consider scenarios wherein the RDI is assumed to be 100%. In sensitivity
12 analyses, the assumed RDI was set to 100% for all treatments and lenalidomide maintenance
13 only to establish the impact on the cost-effectiveness results (see Section 6.1.3 for more
14 information).

15 In the company's model, the cost of lenalidomide was applied at the start of each 28-day cycle.
16 Clinical advice provided to the ERG suggested that some sites may dispense two cycles' worth
17 of lenalidomide (i.e. an eight-week supply), yet it is unclear how many sites this would be the
18 case for. For simplicity, the ERG has considered the costing of lenalidomide once every model
19 cycle.

20 The duration over which the cost of lenalidomide maintenance was applied was based on
21 modelled TTD. As with OS and PFS, parametric models were fitted to data from Myeloma XI,
22 though as TTD is only required for the lenalidomide arm, models were fitted to this arm alone.
23 The TTD curve reflected the safety set (n=582) as n=39 of the ITT set randomised to
24 lenalidomide maintenance did not receive treatment.

25 Goodness of fit statistics (CS, Document B, Table 24) suggested that the exponential model
26 provided the best fit to the Kaplan-Meier curve (according to both AIC and BIC). However, each
27 of the models exhibited a similar visual fit to the Kaplan-Meier curve, with the exception of the
28 log-normal distribution (CS, Document B, Figure 21). The ERG agreed that the exponential
29 model provided a good statistical and visual fit to the Kaplan-Meier curve, as well as plausible
30 longer-term estimates, and therefore was a suitable choice to inform the economic model.
31 Therefore, the exponential model was used to inform the ERG's preferred base-case (Figure

1 11). However, for completeness, alternative specifications of the TTD curve are explored in the
2 ERG's additional sensitivity analyses (see Section 6.1.3).

3 **Figure 11: ERG's preferred extrapolation of TTD**

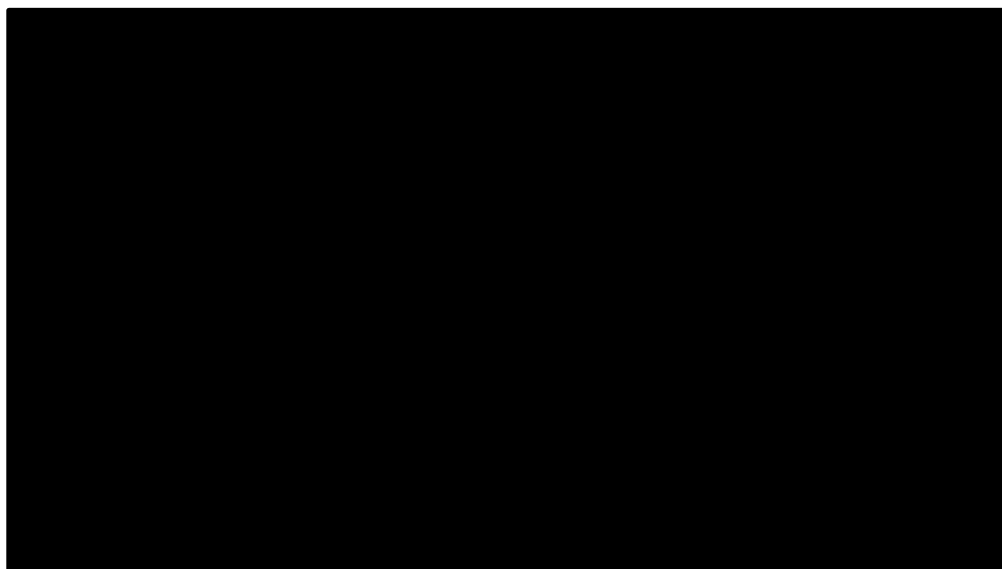

4
5 Key: LEN, lenalidomide maintenance.
6 Note: Plot produced by the ERG.
7

8 **4.2.8.2. Medical resource use**

9 The costs associated with routine monitoring and follow-up (henceforth termed 'medical
10 resource use [MRU]') were applied to both the lenalidomide maintenance and observation arms
11 in the company's model. Unit costs were taken from NHS reference costs, with the exception of
12 the cost for red blood cell transfusion which was taken from a report from NHS Blood and
13 Transplant. The ERG considers the unit costs used to inform the company's model (CS,
14 Appendix N) appropriate.

15 The MRU items captured within the model include routine medical appointments, blood tests,
16 and investigations, as well as red blood cell and platelet transfusions. The ERG is satisfied that
17 the included costs cover the key MRU items expected to be required by patients.

18 In the company's base-case analysis, MRU frequencies were obtained from the published NICE
19 appraisal TA587³¹ (lenalidomide plus dexamethasone for previously untreated multiple
20 myeloma). As a sensitivity analysis, MRU frequencies could also be informed based on a chart

1 review of 61 UK patients. In response to a clarification question asked by the ERG, the
2 company clarified that as only two of the 61 patients received lenalidomide maintenance therapy
3 post-SCT, estimates from TA587³¹ were preferred for use in the base-case on the basis that
4 these had been subject to critical review during TA587³¹ and for consistency between appraisals
5 (Clarification B14).

6 The ERG noted that MRU estimates from one of these sources (UK chart review) causes an
7 increase in the cost per model cycle upon relapse, whereas the other (TA587³¹) suggested a
8 reduction in the cost per model cycle after relapse. No clear explanation was provided to the
9 ERG as to why this apparent contradiction was present within the two alternative sets of
10 assumptions, and so the ERG sought clinical input to understand how resource use may
11 change after relapse.

12 Clinical advice provided to the ERG suggested that there was no major difference in MRU
13 expected following a first relapse between patients in the lenalidomide maintenance group and
14 those who are managed via observation. However, despite no major differences, patients
15 managed with lenalidomide maintenance are expected to incur additional MRU costs compared
16 to the observation group due to the fact that they are being actively treated. More specifically,
17 clinical advice suggested patients managed via observation may be followed up approximately
18 every three months, whereas patients managed with lenalidomide maintenance would be
19 followed up approximately every one to two months (depending on whether or not it is possible
20 for sites to dispense packs of lenalidomide every four or eight weeks).

21 The ERG expected that as patients progressed throughout the remainder of the treatment
22 pathway (after relapse following ASCT), MRU costs would fluctuate depending on an individual
23 patients' experience. However, within the PartSA model structure used by the company, there is
24 no clear means by which a variable approach to capturing MRU costs could be practically
25 incorporated. Furthermore, given that both sources provided point to opposite effects on MRU
26 after relapse, the ERG considers there to be a lack of evidence to suggest any clear change in
27 MRU after relapse that would theoretically persist for the remainder of a patients' lifetime.

28 In the ERG's preferred base-case analysis, the MRU costs incurred per model cycle after
29 relapse were assumed to be the same as those incurred for observation patients that have yet
30 to relapse. In addition, the cost incurred for the observation arm prior to relapse was reduced by
31 halving the estimated oncologist/haematologist visit costs (compared to the lenalidomide arm).
32 Halving the number of outpatient visits prior to relapse is intended to reflect the expectation that

1 observation patients would be seen less frequently compared to those that are managed with
2 lenalidomide maintenance.

3 Within the company's model, an option was included to specify a cost for terminal care, though
4 this cost is disabled in the base-case analysis. Without additional information concerning the
5 potential for double counting MRU costs towards the end-of-life for this patient population, the
6 ERG opted to not include terminal care costs within its preferred base case, but noted that this
7 may be of relevance and has therefore considered the impact of including these costs within
8 sensitivity analysis (see Section 6.1.3 for more information).

9 4.2.8.3. Resolution of adverse events

10 The unit costs associated with the resolution of AEs were taken from the NHS reference costs
11 (2017–2018; CS Table 30), weighted by activity across each complication score to capture the
12 average severity. In general, the ERG agreed with the company's approach to costing AEs
13 within the model. However, the ERG had a number of relatively minor comments concerning the
14 suitability of specific costs to inform the model:

- 15 • **Anaemia** is costed as 'Iron Deficiency Anaemia'. It is the ERG's understanding that
16 anaemia related to lenalidomide (as with a number of other anticancer treatments) is not
17 necessarily related to iron deficiency, and therefore this cost may not be truly representative
18 of the type of anaemia experienced by patients treated with lenalidomide maintenance
- 19 • **Sepsis** is costed the same as per infections and infestations at £403.78. In reality, patients
20 with Grade III or IV sepsis are expected to require an extended hospital stay – for example,
21 a study by Levy et al. (2012)³² found the median length of stay in hospital for patients with
22 severe sepsis and septic shock was 22.8 days, including 7.8 days in an intensive care unit.
23 Consequently, the average cost of treating patients with sepsis may be underestimated
24 within the company's model

25 Nevertheless, given the small impact of AEs on the total costs associated with lenalidomide
26 maintenance, the ERG considered the company's approach to be suitable for decision making.

27 4.2.8.4. Subsequent treatments

28 In the Myeloma XI study,⁷ all patients received further antimyeloma treatment after the first
29 relapse, and ■ received treatment after a recorded second relapse. Accordingly, the
30 company's model included the costs associated with subsequent treatment lines based on the

1 frequencies of further treatments lines, drug and administration costs and duration of treatment.
2 Costs associated with the resolution of AEs related to subsequent treatments were not captured
3 within the company's model as the company considered it likely that these would reflect a "very
4 small proportion" of the overall incremental costs associated with lenalidomide maintenance
5 versus observation.

6 The company's base-case analysis includes subsequent therapies that are routinely
7 commissioned by the NHS in current practice. An unavoidable consequence of omitting
8 treatments only available via the CDF from consideration within the model is that the distribution
9 of medicines that may be used after the first and second relapses does not reflect the options
10 used in NHS practice at the time of writing this report.

11 Clinical advice provided to the ERG clarified that within the context of MM, treatments that are
12 available via the CDF (to an extent) address a lack of options that would otherwise be possible
13 to logically use in sequence. For example, the same patient should not ideally be treated with a
14 predominantly bortezomib-based regimen (e.g. bortezomib + dexamethasone) in three
15 successive treatment lines (e.g. as induction, after first relapse, and then again after second
16 relapse); and so without the possibility of considering CDF treatments, options after second
17 relapse are extremely limited. This problem is exacerbated further within the context of a
18 lenalidomide maintenance arm, for which subsequent treatments containing lenalidomide are
19 not expected to be considered.

20 In the company's base-case analysis, the costs of subsequent therapies are informed via a UK
21 clinical expert survey, though this mix of treatments is markedly different from the mix received
22 by the Myeloma XI⁷ population. Furthermore, the clinician survey was later re-weighted to
23 remove options only available via the CDF. The ERG considered the following assumptions
24 require careful consideration:

- 25 • Pomalidomide cannot currently be used in practice after the first or second relapse (based
26 on NICE TA427³³ guidance).
 - 27 – Thus, the ERG does not consider this option to be relevant for inclusion within the
28 model (given that only two subsequent treatment lines are captured).
- 29 • Carfilzomib (+ dexamethasone) cannot be used in the majority of patients after SCT, as
30 induction regimens typically include the use of bortezomib. NICE TA457³⁴ guidance states

1 that carfilzomib is recommended only for patients that have not previously received
2 bortezomib.

3 – Consequently, within the hypothetical treatment landscape wherein CDF treatments
4 do not exist, there may be an incentive for clinicians to consider using a less effective
5 induction regimen to preserve the ability for patients to receive carfilzomib after
6 relapse

7 – However, assuming all patients are managed per current practice, no patients would
8 be eligible for carfilzomib after relapse and therefore the ERG does not consider this
9 option to be relevant for inclusion within the model.

10 • If daratumumab (+ bortezomib + dexamethasone) were no longer an option for patients
11 after relapse, clinical advice provided to the ERG noted that a second SCT may then be
12 considered (which is permitted based on NICE guidance).³⁵

13 – However, the company's base-case does not include the option for a second SCT,
14 as the original values included the option for daratumumab.

15 – Therefore, the company's re-weighted assumptions may not truly reflect clinical
16 opinion were CDF options not available (as the question being posed to clinicians is
17 fundamentally different than what was originally asked).

18 • Clinical advice provided to the ERG clarified that there is no evidence to suggest a
19 difference in the proportion of patients that would receive *any* subsequent treatment based
20 on whether or not a patient was managed with lenalidomide maintenance or not (except
21 that patients who have previously received lenalidomide would not receive another
22 lenalidomide-containing regimen)

23 – Through the re-weighting undertaken by the company to omit CDF regimens, a
24 difference in the proportion of patients expected to receive any subsequent treatment
25 was (perhaps unintentionally) introduced

26 With these limitations in mind, the ERG produced its own set of preferred assumptions relating
27 to subsequent therapies, based loosely on the company's base-case assumptions and edited
28 based on clinical advice provided to the ERG. A comparison of the company's base-case and

1 the ERG's preferred assumptions is presented in Table 18. The key changes assumed in the
2 ERG's base-case analysis were:

- 3 • The same proportion of patients are expected to receive any treatment across both arms,
4 but this is expected to be higher after the first relapse compared to after the second relapse
- 5 • A second ASCT is expected to be an option for patients after first relapse (in the absence of
6 a daratumumab-based regimen being available), most notably for lenalidomide
7 maintenance patients who are expected to have experienced a relatively longer period of
8 remission
 - 9 – It is difficult however to estimate the proportion of patients that may go on to receive a
10 second ASCT, as in current NHS practice patients are managed with daratumumab +
11 bortezomib + dexamethasone (a CDF-funded regimen) instead
- 12 • Use of lenalidomide for observation patients after the first relapse may be higher than the
13 estimate included in the company's base-case, due to a lack of other options (given that
14 bortezomib is expected to be used as induction)
- 15 • Pomalidomide and carfilzomib regimens removed as options, to align with NICE guidance

16 The ERG highlighted that these estimates are based on very limited evidence concerning a
17 hypothetical treatment landscape, and should therefore also be interpreted with caution.

18 **Table 18: Comparison of company's and ERG's preferred subsequent therapy settings**

Option	Company's base-case				ERG's base-case			
	Post 1 st relapse		Post 2 nd relapse		Post 1 st relapse		Post 2 nd relapse	
Arm	Len	Obs	Len	Obs	Len	Obs	Len	Obs
Len + dex		■		■		30.0%		70.0%
Bor + dex	■	■	■	■	60.0%	40.0%	20.0%	10.0%
Car + dex		■						
Pan + bor + dex			■	■			20.0%	5.0%
ASCT					15.0%	5.0%		
Pom			■					
Other	■	■	■	■	20.0%	20.0%	50.0%	5.0%
No treatment	■	■	■	■	5.0%	5.0%	10.0%	10.0%

19 Key: ASCT, autologous stem cell transplant; bor, bortezomib; car, carfilzomib; dex, dexamethasone; ERG, Evidence
20 Review Group; len, lenalidomide; obs, observation; pan, panobinostat; pom, pomalidomide.

1 Note: For the purpose of informing the economic model, ASCT is considered in one line which may be under-costed
2 when taking into account the costs of a reinduction regimen.

3
4 To include the costs of further treatment, the model calculated the average cost associated with
5 subsequent treatments for each treatment arm and applies this based on the proportion of
6 patients experiencing a PFS event at each model cycle. In other words, subsequent therapy
7 costs are estimated based on a micro-costing approach and are then applied as a lump sum
8 upon assumed progression. To account for discounting, the model made use of the continuous
9 discounting function, and the estimated post-progression costs are capped if the model time
10 horizon is restricted.

11 The approach taken to include subsequent therapy costs within the model has a number of
12 important methodological limitations. The data used to estimate the costs of subsequent
13 therapies are independent of health state occupancy – that is, the duration of time spent in
14 progressed disease is independent of the assumed duration of treatments after first and second
15 relapse. The company's base-case analysis estimates the following for each treatment arm:

- 16 • **Lenalidomide:** an average of ■■■ LYs are accrued in the progressed state; of which ■■■
17 are accrued while receiving subsequent treatment. This is equivalent to approximately ■■■ of
18 time spent in progressed disease being on treatment
- 19 • **Observation:** an average of ■■■ LYs are accrued in the progressed state, of which ■■■ are
20 accrued while receiving subsequent treatment. This is equivalent to approximately ■■■ of
21 time spent in progressed disease being on treatment

22 Through inspection of the values reported above, it can be ascertained that for every ■■■ months
23 a lenalidomide patients receives subsequent therapy after relapse, an observation patient is
24 assumed to be treated for approximately ■■■ months. The ERG did not consider this difference in
25 estimated post-progression treatment duration to be fully justified.

26 In addition to the concern around the estimation duration of subsequent treatment (which is not
27 linked to health state occupancy), subsequent therapy costs after the second relapse are not
28 captured by the model. It is the ERG's understanding that post-progression survival for patients
29 treated with lenalidomide maintenance is expected to be greater than post-progression survival
30 for patients managed with observation (based on the company's base-case model results). If

1 true, this is likely associated with greater utilisation of further lines of therapy, which may have
2 important impacts on the total costs accrued over a patients' lifetime.

3 At clarification, the ERG asked the company to provide a scenario analysis where a 'cost-per-
4 cycle' for subsequent therapies was considered (as opposed to a 'pay-off' approach, used in the
5 company's base case). When considering this approach, and using the same input parameters,
6 the total incremental costs were estimated to [REDACTED] from [REDACTED] to [REDACTED] (i.e. [REDACTED] by a
7 total of [REDACTED]). The potential reason behind this marked difference in estimated costs is
8 purported to be due to the time spent post-progression being "*on average greater than the*
9 *duration of treatment assumed for subsequent therapies*" (Company response to B9). The ERG
10 agrees that the large difference in costs is due to a large difference assumed in durations of
11 subsequent treatment, highlighting that a substantial proportion of the time spent in progressed
12 disease is assumed to be off treatment in the company's model.

13 Of the two approaches presented ('cost-per-cycle' versus 'pay-off' approach), the ERG
14 considered the pay-off approach to be more suitable for the purpose of informing the model.
15 However, the ERG also highlighted that such an approach is inherently flawed owing to the
16 discordance between the estimation duration of subsequent therapy and the time spent in the
17 progressed disease state. Given that the company's base-case analysis implied a cost saving
18 related to subsequent therapies of [REDACTED] versus incremental costs associated with
19 lenalidomide maintenance of [REDACTED], the ERG urged extreme caution when considering the
20 potential impact of subsequent therapies on model results.

21 In terms of the costs applied for each of the subsequent therapy regimens, the ERG raised the
22 following concerns:

- 23 • The cost of bortezomib is available via the Drugs and pharmaceutical electronic market
24 information tool (eMIT), and so the ERG has updated this cost
25 [REDACTED]
- 26 • The cost of the 'other' regimen is based on assumption. Clinical advice provided to the ERG
27 suggested that this would likely resemble the CTD regimen, and so the ERG amended the
28 cost of 'other' to align with this regimen in its base-case analysis

29 In the ERG's preferred base-case analysis, the breakdown of therapies given after relapse was
30 edited, as well as the costs associated with bortezomib and the "other" regimen. However, the
31 ERG noted that it remained unclear if there would be any cost savings associated with giving

1 maintenance therapy as the application of subsequent therapy costs in the model is technically
2 limited and reliant upon a number of highly-influential assumptions. As with the estimation of
3 costs for lenalidomide (Section 4.2.8.1), it was unclear to the ERG if the inclusion of RDI values
4 was aligned with the true costs of product acquisition. Therefore, an additional sensitivity
5 analysis was conducted wherein all RDI values were set to 100%.

1 5. COST-EFFECTIVENESS RESULTS

2 In the original CS, some treatment options included in subsequent lines are (at the time of
3 writing) available only via the CDF. At clarification stage, the company submitted a revised
4 model, which was later followed by an addendum containing a revised Section 6 of the CS.
5 Accordingly, this section of the ERG report contains updated results reported in the revised CS.

6 However, in consideration of the revised model and corresponding results, the ERG highlights
7 that the following changes were also introduced within the company's revised base-case in
8 addition to the change in subsequent therapy distribution:

- 9 • **Cohort starting age and gender split:** The original company model had a starting age of
10 66 years (CS Section B.3.2.2), yet the revised model considers a starting age of 59 years.
11 In addition, the original company model considered a 50:50 split of males and females, yet
12 the revised model considers a 38% female population. At clarification stage, the company
13 noted that this discrepancy was due to the differences between the full Myeloma XI⁷ trial
14 population, and the population of direct relevance to this appraisal
- 15 • **Proportion of cohort modelled to receive lenalidomide maintenance:** In the original
16 company model, 100% of patients were assumed to initiate lenalidomide maintenance.
17 However, in the revised model, only the safety population (93.7%) were assumed to incur
18 the costs of lenalidomide maintenance. At clarification stage, the company clarified that the
19 original implementation was an error
- 20 • **Patients receiving therapy after 1st and 2nd relapse:** The original company model
21 estimated that 98% and 60% of patients (across both arms) would receive subsequent
22 therapy after 1st and 2nd relapse, respectively. However, the revised model suggests 100%
23 of patients would receive subsequent therapy after 1st and 2nd relapse

24 The first of these two changes were described within the company's clarification response, yet
25 the latter change (concerning the proportion of patients receiving therapy after 1st or 2nd relapse)
26 was not described in the company's clarification response, nor was it discussed within the
27 company's addendum. However, given that within the distribution of subsequent treatments an
28 option for "no treatment" is specified, the ERG considers it appropriate that 100% of patients
29 used to inform this calculation.

1 5.1. Company’s cost-effectiveness results

2 5.1.1. Base case results

3 Results of the company’s base-case analysis are presented as an ICER for lenalidomide
 4 maintenance compared to observation. Disaggregated costs, QALYs and LYs are presented in
 5 CS Table 36, replicated in Table 19 below. [REDACTED]

6 [REDACTED]
 7 [REDACTED]
 8 [REDACTED]
 9 [REDACTED]

10 **Table 19 Company base case results**

Arm	Total			Incremental			ICER (£/QALY)
	Costs (£)	LYs	QALYs	Costs (£)	LYs	QALYs	
Company base-case (deterministic)							
Observation	[REDACTED]	[REDACTED]	[REDACTED]				
Lenalidomide	[REDACTED]	[REDACTED]	[REDACTED]	[REDACTED]	[REDACTED]	[REDACTED]	[REDACTED]

11 Key: ICER, incremental cost-effectiveness ratio; LY, life year; QALY, quality adjusted life year.

12
 13 The company reported a base-case ICER of [REDACTED] for lenalidomide maintenance versus
 14 observation, based on incremental costs of [REDACTED] and a QALY gain of [REDACTED]. However, the ERG
 15 notes that this analysis does not reflect agreed discounts that are available to the NHS for all
 16 included treatments. Results including all relevant PAS price discounts for lenalidomide and
 17 subsequent treatments are provided in a confidential addendum to this report.

18 The base-case analysis projects [REDACTED] incremental, undiscounted LYs gained for patients treated
 19 with lenalidomide maintenance, of which [REDACTED] were gained in the ‘pre-progression’ health state,
 20 leaving [REDACTED] which were gained in the ‘progressive disease’ state. This finding illustrates that the
 21 majority of LYs gained by patients treated with lenalidomide maintenance were accrued within
 22 the ‘pre-progression’ health state, yet a notable proportion of the benefit associated with
 23 lenalidomide maintenance is also accrued in the ‘progressive disease’ state.

1 5.2. Company's sensitivity analyses

2 The CS reported a number of sensitivity analyses to explore the impact of alternative settings
3 and assumptions, as well as the role of parameter uncertainty within the model results. These
4 analyses are discussed in turn below.

5 5.2.1. One-way sensitivity analysis

6 The company conducted a deterministic one-way sensitivity analysis (OWSA) to “*evaluate the*
7 *parameter uncertainty of individual inputs, holding all else constant.*” (CS Section B.3.7.2). The
8 parameters included within the OWSA are presented in CS Table 34 however, the ERG noted
9 that MRU costs were not actually varied in the economic model. Thus, the model assumed there
10 was no uncertainty in the estimation of MRU costs. The CS stated that where information was
11 available, parameters were varied using 95% confidence intervals, otherwise upper and lower
12 bounds were varied by $\pm 15\%$ of the (mean) base-case value.

13 Tornado plots were used to present the OWSA results in CS Figure 24, with the outcome of
14 interest being net monetary benefit. The ERG notes that the company did not state the
15 threshold used for the OWSA results provided in Figure 24 (which consider the outcome of net
16 monetary benefit), although this was determined to be £30,000 when investigated within the
17 economic model.

18 The plot showed results were most sensitive to the proportion of patients on subsequent
19 treatments, with seven of the 10 most influential parameters being related to these distributions.
20 The remaining three parameters (mean body surface area [BSA], proportion of observation
21 patients receiving subsequent therapy and number of carfilzomib + dexamethasone treatment
22 cycles) also directly influenced subsequent therapy, given that lenalidomide maintenance is not
23 dosed according to BSA.

24 The ERG noted that the inclusion of the distribution of subsequent therapies in the OWSA was
25 somewhat inappropriate as the proportion of patients receiving each treatment were set to sum
26 to 100% for each arm at each line. When varying the proportion of patients receiving a
27 treatment, the proportion receiving another treatment therefore also changes. Thus, these
28 parameters cannot be varied independently within an OWSA (given that such an analysis is
29 based on holding all other parameters at their default values). Owing to the inclusion of
30 parameters that were not deemed appropriate within an OWSA, the remainder of the ERG's
31 report focuses on the other sensitivity analyses provided.

1 5.2.2. Probabilistic sensitivity analysis

2 The company conducted a probabilistic sensitivity analysis (PSA) to explore the impact of
3 parameter uncertainty, based on each model parameters' respective distribution (listed in CS
4 Table 34). However, the ERG found some distributions implemented in the economic model
5 differed from those detailed in the CS, with some parameters not varied at all, as well as a
6 number of other concerns with the approach taken to perform PSA:

- 7 • The CS reported that beta distributions were assigned to AE rates; however, the economic
8 model used gamma distributions on the number of AE events reported in Myeloma XI⁷
 - 9 – The ERG considered this approach reasonable, however as the duration of exposure
10 is not varied, the true uncertainty associated with AE rates may not be reflected
11 within the model
- 12 • The distribution of subsequent therapies was reported to be assigned a gamma distribution
13 in the CS, while the economic model implements a Dirichlet distribution for these
14 parameters
 - 15 – The ERG considered this appropriate in order to account for the fact that the sum
16 total of these proportions should equal 100%
 - 17 – However, the ERG does not agree with the assignment of parameter uncertainty for
18 these proportions – namely, the model assumes the sum of the elements in the α
19 vector (α_0) is equal to the number of respondents (██████). The value of α_0
20 ultimately influences the strength of the distribution (i.e. the overall spread of
21 responses), and there is no clear reason why this should be based on the number of
22 respondents
 - 23 – To illustrate the impact on this assumption on model values, a sample of 1,000
24 iterations for the distribution of treatments provided for lenalidomide maintenance
25 patients after first relapse was taken. The proportion of patients treated with
26 bortezomib + dexamethasone (base-case value: █████) was between █████ and █████
 - 27 – In the absence of other information to inform the measure of uncertainty, the ERG
28 has not edited these values within the model

- 1 • The CS stated that lognormal distributions were used to vary AE costs, though the
2 economic model uses gamma distributions
- 3 – The ERG preferred the use of a normal distribution to vary cost data within the
4 context of a cohort-level model. This is because the distribution around a mean cost
5 will resemble a normal distribution when a large number of repeated samples are
6 taken, due to the Central Limit Theorem
- 7 – A gamma distribution would be the ERG’s preferred choice within the context of an
8 individual-level model (such as a discrete event simulation) wherein the costs borne
9 by individual patients may be expectedly skewed, yet this is not expected to be a
10 feature of the mean cost for a cohort of patients
- 11 • The CS also reported lognormal distributions were used to vary MRU rates and costs;
12 however, in the economic model these were not assigned a distribution for the PSA and
13 thus were not varied
- 14 – Consequently, the PSA assumed no uncertainty around the frequency and cost of
15 MRU values included within the model
- 16 • Utility values for pre-progression and progressive disease were varied independently, which
17 leads to some instances of a utility increase upon progression
- 18 – While the probability of this occurring is less than 1% (based on an exploratory
19 analysis conducted by the ERG, again using 1,000 iterations), this was not listed as
20 a limitation in the CS

21 PSA results are summarised in CS Table 37 and CS Figures 22 (cost-effectiveness plane) and
22 23 (cost-effectiveness acceptability curve [CEAC]).

23
24 The PSA results from the CS are similar to the deterministic base-case results. The
25 company stated that at willingness to pay thresholds of £20,000 and £30,000 per QALY gained,
26 the probability of lenalidomide maintenance being cost-effective versus observation was ■ and
27 ■, respectively. The ERG replicated the PSA using the company base case and achieved
28 results within 1% of those reported. However, the ERG noted that the uncertainty for some
29 parameters was inadequately explored (e.g. MRU rates and costs), and the PSA results may
30 not appropriately reflect the joint uncertainty of some parameters (e.g. utility values).

1 5.2.3. Scenario analyses

2 The company conducted a number of scenario analyses to assess the impact of structural
3 uncertainties and alternative settings/ assumptions on the base-case results. Results are
4 provided in Table 38 of the CS. Following the requests at the clarification stage, additional
5 scenarios were explored within the revised CS Section 6.

6 The company concluded that the [REDACTED]
7 [REDACTED] (CS Section B.3.7.4) however, [REDACTED]
8 [REDACTED] (CS Section Table 38).
9 In addition to the shortening of the time horizon, the removal of subsequent therapies was also
10 associated with an increased ICER.

11 The functionality to include administration costs for oral therapies appears to have been
12 disabled in the company's model and therefore, this scenario saw no change in the ICER. The
13 ERG did not explore the impact of including these costs further owing to the lack of clarity
14 concerning its implementation (and given that lenalidomide is expected to be self-administered),
15 but highlights this as an outstanding area of uncertainty. In addition, the ERG noted that the
16 scenario of 'Discount rate: 1.5% benefits, 6% costs' was provided with no rationale for why this
17 scenario was conducted.

18 The scenario analyses presented were limited in number, with none exploring the impact of
19 survival extrapolation assumptions (a detailed critique of the company's preferred extrapolations
20 is provided in Section 4.2.6). Alternative distributions of subsequent therapies were not
21 appropriately investigated, despite limitations with the base case proportions which were
22 redistributed from the clinical advice provided to the company, in order to reflect no use of CDF
23 drugs (detailed critique of the redistribution is provided in Section 4.2.8.4). The scenario
24 analysis of subsequent therapies based on Myeloma XI was considered inappropriate as the
25 CDF regimen of ixazomib + lenalidomide + dexamethasone was still reflected within the
26 company's revised model, and therefore the implementation of this scenario is not correctly
27 redistributed to exclude CDF treatments.

28 5.3. Model validation and face validity check

29 The ERG performed a range of validation checks on the economic model and identified an error
30 with the 'reset to base case' macro prior to the clarification stage which was subsequently
31 corrected by the company. The deterministic base case results presented in the CS were

1 replicable by the ERG; however, the OWSA and PSA results were only replicable when using
2 the settings left in the economic model by the company. When the model settings were aligned
3 with those described in the CS, the results differed.

4 The clinical results exhibited face validity with improved OS and PFS for lenalidomide
5 maintenance compared to observation. Furthermore, the PSA reported in the CS resulted in
6 positive a QALY gain, ranging between approximately ■■■ and ■■■ (values taken from the
7 economic model) for each of the 1,000 simulations. The cost outcomes lack clarity on whether
8 lenalidomide maintenance is associated with cost saving or increased expenses, with
9 incremental costs ranging from ■■■■■ to ■■■■■ (values taken from the economic model). The
10 wide interval indicates uncertainty in the cost impact of lenalidomide maintenance however, the
11 majority of points on the CEAC lie in the cost-incurring region of the plot.

12 The company provided a comparison of four other published cost-effectiveness analyses for
13 lenalidomide maintenance versus observation (CS, Section B.3.1). Similar clinical outcomes to
14 those obtained in the company's analysis were observed, with large differences seen in the
15 incremental costs. These variations are likely due to differences in region, perspective and time
16 horizon. However, for each of the published studies with non-redacted information concerning
17 costs, the estimated incremental costs associated with lenalidomide maintenance were greater
18 than zero.

6. EVIDENCE REVIEW GROUP'S ADDITIONAL ANALYSES

6.1. Exploratory and sensitivity analyses undertaken by the ERG

The ERG carried out a number of exploratory and sensitivity analyses, which are described in turn below. Due to the fact that the correlation between many model parameters is not fully reflected by the PartSA model structure used by the company (as acknowledged by the company in its submission, CS Section B.3.9); the ERG has opted to focus on predominantly deterministic sensitivity analyses. However, the ERG's preferred base-case analysis was re-run in a PSA for completeness.

6.1.1. Estimation of overall survival

In Section 4.2.6.1, the uncertainty surrounding the estimation of OS for both the lenalidomide maintenance and observations arms was highlighted. To explore the impact of estimates relating to OS further, the ERG conducted the following additional analyses:

- Assessment of structural uncertainty concerning choice of parametric model distribution, by considering joint and independently fitted combinations of the Weibull and log-logistic models across both treatment arms
- Exploration of a potential waning of treatment effect, by imposing an assumed HR of 1.0 for the outcome of OS for lenalidomide maintenance versus observation after a given point in time (starting at five years, until which point in time there is evidence of the PH assumption holding)
 - The ERG appreciates such an analysis is inherently limited owing to the specification of an AFT model (joint log-logistic) for OS, but has presented the analysis in spite of this as a pragmatic means of exploring the potential longevity of treatment effect
- Heatmap combining assumed duration of treatment effect and impact of subsequent therapies (see Section 6.2).

1 6.1.2. Subsequent therapies

2 In Section 4.2.8.4, the challenges concerning subsequent therapies were discussed. To further
3 investigate the impact of subsequent therapies on the model results, the following analyses
4 were undertaken:

- 5 • Removal of all subsequent therapy costs, to establish the impact of cost savings relating to
6 later treatment(s) on the estimated ICER.

- 7 – This is equivalent to removing the category of subsequent therapy costs from the
8 total incremental costs estimate.

- 9 • Threshold analysis of potential costs or cost savings related to subsequent therapies.

- 10 – This analysis essentially ignores the estimation of subsequent therapy costs, and
11 instead specifies a given expected difference in subsequent therapy costs outside of
12 the model calculations.

- 13 • Heatmap combining impact of subsequent therapies with assumed duration of treatment
14 effect (Section 6.2).

15 6.1.3. Miscellaneous

16 In addition to the analyses concerning OS and subsequent therapies, the ERG performed a
17 range of additional analyses based on the following topics:

- 18 • Use of CALGB 100104^{3,4} curves for the estimation of OS, PFS, and TTD, including an uplift
19 to the costs of lenalidomide to reflect a 1–28 day regimen per the regimen used in CALGB
20 100104 (Section 4.2.6).

- 21 • Delaying age adjustment on utility by five years (Section 4.2.7).

- 22 • Removal of all assumptions relating to RDI, and setting all values to 100%, as well as
23 setting the RDI for lenalidomide maintenance only to 100% (Section 4.2.8).

- 24 • Including terminal care costs of £7,157, based on an option provided in the company's
25 model (Section 4.2.8).

- 26 • Use of alternative parameterisations for PFS and TTD, based on models provided next-best
27 statistical fit (Sections 4.2.6 and 4.2.8)

1 **6.2. Impact on the ICER of additional clinical and economic analyses**
 2 **undertaken by the ERG**

3 The results of additional sensitivity analyses conducted by the ERG are provided in Table 20.
 4 The analyses that had the greatest impact on the ICER were related to the costing of
 5 subsequent therapies, using CALGB 100104^{3,4} data, the choice of OS model, and the removal
 6 of RDI values.

7 **Table 20: Additional sensitivity analyses (centered on company base case)**

Model setting(s)	ICER £/QALY
Company base-case	██████
All subsequent therapy costs removed	██████
Delay impact of age adjustment on utility by 5 years	██████
Include terminal care costs of £7,157	██████
Use CALGB 100104 curves + costing	██████
Use Weibull for TTD	██████
Use Gompertz for TTD	██████
Use (joint) Weibull for PFS	██████
Use (joint) log-logistic for PFS	██████
Use independent Weibull (Obs) and independent Weibull (Len) for OS	██████
Use independent log-logistic (Obs) and independent log-logistic (Len) for OS	██████
Use independent Weibull (Obs) and independent log-logistic (Len) for OS	██████
Use independent log-logistic (Obs) and independent Weibull (Len) for OS*	██████
Use dependent Weibull for OS	██████
Use dependent log-logistic for OS	██████
Set RDI for all treatments to 100%	██████
Set RDI for lenalidomide maintenance only to 100%	██████

8 Key: ICER, incremental cost-effectiveness ratio; QALY, quality adjusted life year.

9 Note: *ICER is noticeably higher due to OS curves projected to cross at approximately 11 years

10

11 In addition to the analyses presented in Table 20 the findings of the threshold analysis
 12 concerning the anticipated duration of treatment effect are presented in Figure 12. This plot
 13 demonstrates the relationship between the ICER and an assumed timepoint at which the
 14 hazards of death would be identical across the treatment arms.

1 Due to the specification of two substantially different parameterisations of OS across each
2 treatment arm in the company's base case, the corresponding OS models do not exhibit clear
3 face validity (as may also be inferred through inspection of the implied HR over time in the
4 company's base-case analysis, Figure 5). A more detailed critique of the company's base-case
5 approach to modelling OS is provided in Section 4.2.6.1. In spite of this limitation, the analyses
6 were conducted to illustrate the potential influence of adjusting survival extrapolations on the
7 ICER (given that the company did not provide any scenarios concerning alternative survival
8 extrapolations within its submission). The equivalent results are also presented for the ERG's
9 preferred base-case extrapolation of OS.

10

Figure 12: ERG analysis: Assumed duration of treatment effect versus ICER

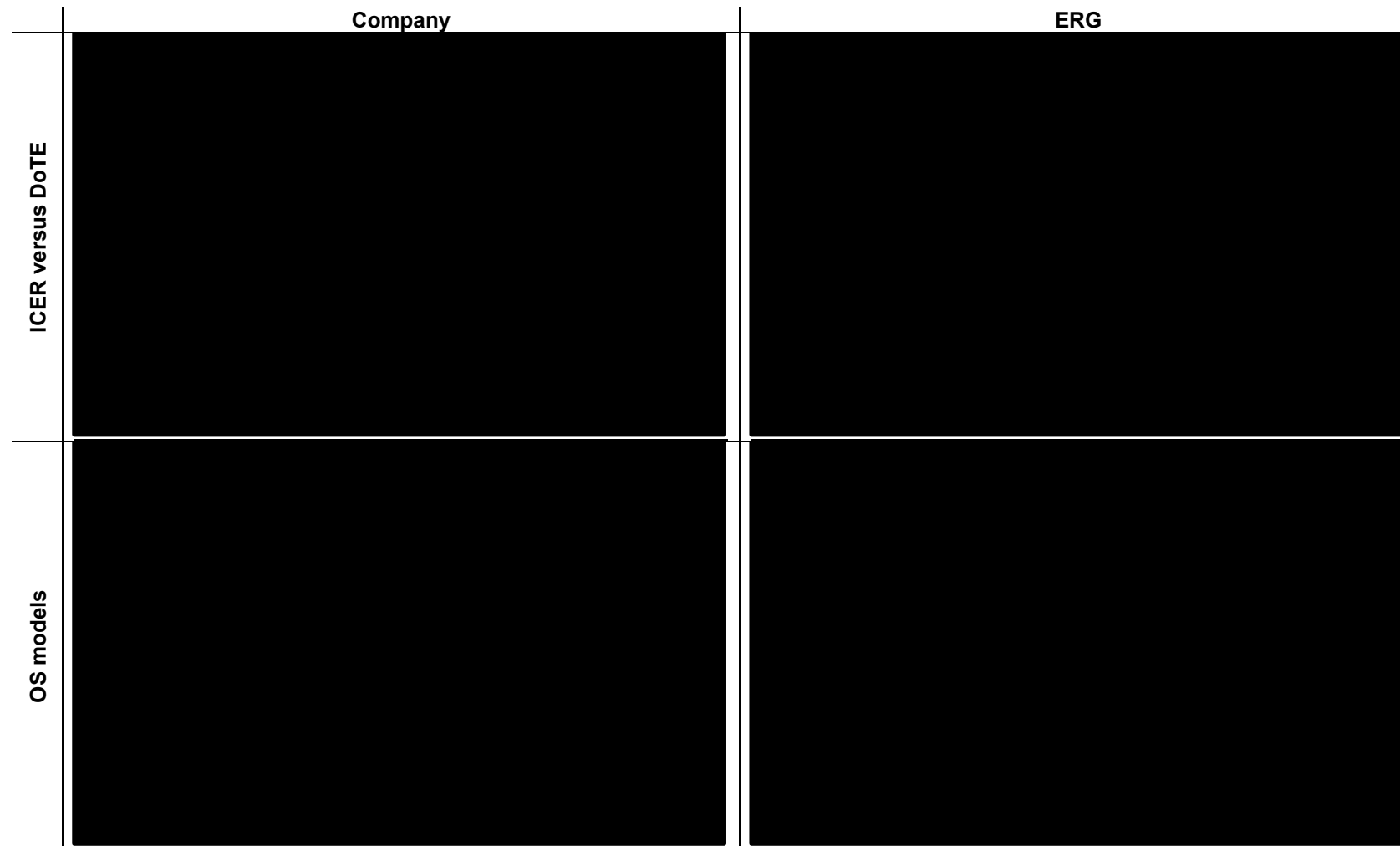

Key: DoTE, duration of treatment effect; ERG, Evidence Review Group; ICER, incremental cost-effectiveness ratio; Obs, observation; OS, overall survival.

In addition to the exploration of OS, the ERG also conducted an analysis specifically focused on the estimated costs of subsequent therapy. In the company's base-case analysis, the incremental cost savings attributable to subsequent therapy was [REDACTED]. However, in sensitivity analyses provided by the company at clarification stage, the estimated cost savings were between [REDACTED] and [REDACTED]. Given that the application of subsequent therapy cost savings is sufficiently disjointed from the economic model structure, the ERG has explored the impact on the ICER were the costs related to subsequent therapies varied in isolation of all other parameters.

Figure 13 demonstrates the relationship between the estimated costs (or cost savings) related to subsequent therapies and the ICER, varied from potential cost savings of up to £100,000 and potential incremental costs of up to £100,000. The result when subsequent therapy costs are completely omitted from the model are shown in Figure 13 where the x-axis is zero, and the company's base-case estimate is shown as a dashed line.

Figure 13: ERG analysis: subsequent therapy cost savings versus ICER

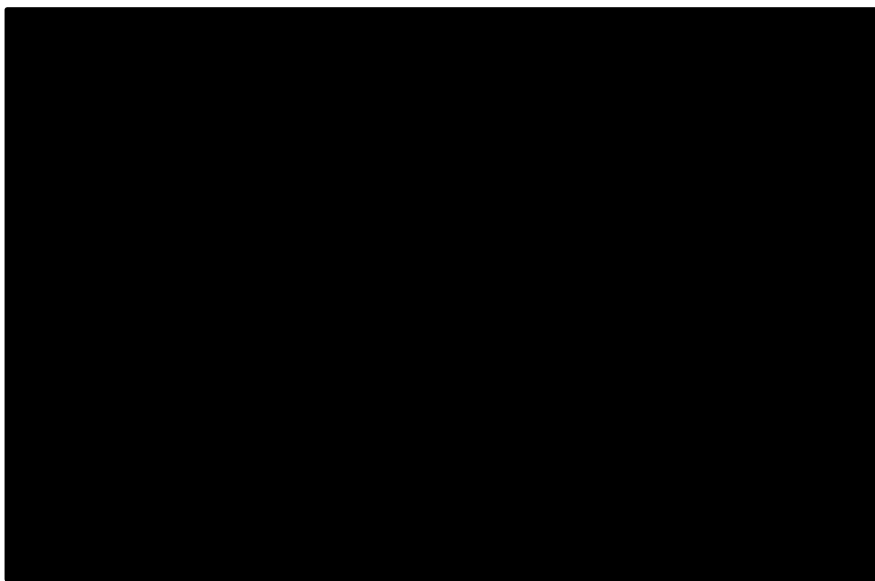

Key: ICER, incremental cost-effectiveness ratio.

The results from this analysis illustrated that in isolation of all other changes that may be made to the company's base-case analysis, if the incremental costs associated with subsequent therapy after lenalidomide maintenance are no greater than approximately [REDACTED], then the ICER is less than £30,000. However, in order to achieve an ICER of [REDACTED], lenalidomide

maintenance would need to be associated with cost savings due to subsequent therapies of at least [REDACTED]. [REDACTED]

A heat map combining the impact of subsequent therapy cost savings and an assumed duration of treatment effect is provided in Figure 14. This analysis illustrated the joint impact of cost savings relating to subsequent therapies and potential differences in long-term treatment effect that may (in part) capture a variable clinical impact of subsequent therapies. The methods used to explore subsequent therapy costs and the duration of treatment effect are described in further detail within Section 6.1.

The heat map demonstrated that the company's base-case results (shown in the heat map in purple) are driven largely by a combination of both of these assumptions. Below are some specific interpretations of particular note:

- Based on the company's base-case analysis, nearly all patients ([REDACTED]) are expected to have discontinued lenalidomide maintenance after [REDACTED] years, yet differences can be seen in the ICER beyond this time owing to an assumed lifelong benefit.
- Regardless of the assumed duration of treatment effect, if subsequent therapies are not associated with any cost savings (as implied by the company's base-case analysis) the ICER is consistently greater than [REDACTED].
- If all benefits associated with lenalidomide maintenance no longer applied (in terms of the estimated hazard of death) after five years (end of follow-up in Myeloma XI⁷), cost savings for subsequent therapies would need to be at least [REDACTED] in order to yield an ICER of less than [REDACTED].

Figure 14: ERG analysis: Heat map of duration of treatment effect versus subsequent therapy cost savings



Key: k, thousand(s).

Note: Region highlighted in purple equates to company's base-case settings/ assumptions.

6.3. ERG's preferred assumptions

In spite of the limitations highlighted within the company's model, the ERG determined its set of preferred settings and assumptions. However, the ERG emphasised that a broader question remains unanswered concerning the potential costs associated with subsequent therapies that cannot be fully integrated within the ERG's preferred assumptions.

The ERG's preferred model settings and assumptions are summarised in Table 21. The cumulative impact of each setting on the estimated ICER is presented alongside each change. The results presented are aligned with the base-case results provided by the company, including equivalent settings and assumptions relating to PAS discounts.

Table 21: ERG's preferred model assumptions (company PAS settings)

Preferred assumption	Section in ERG report	Cumulative ICER £/QALY
Company base-case	Section 5.1.1	████
Set OS curve to joint log-logistic	Section 4.2.6.1	████
Set PFS curve to joint Weibull	Section 4.2.6.2	████
Set RDI for lenalidomide maintenance to 94.9%	Section 4.2.8.1	████
Set MRU costs post-relapse same as pre-relapse	Section 4.2.8.2	████
Halve pre-relapse outpatient visits for observation	Section 4.2.8.2	████
ERG's preferred subsequent treatment settings	Section 4.2.8.4	████
Set cost of "other" equivalent to CTD regimen	Section 4.2.8.4	████
Set cost of bortezomib from eMIT	Section 4.2.8.4	████

Key: CTD, cyclophosphamide + thalidomide + dexamethasone; eMIT, electronic market information tool; ERG, Evidence Review Group; ICER, incremental cost-effectiveness ratio; MRU, medical resource use; OS, overall survival; PFS, progression-free survival; QALY, quality adjusted life year; RDI, relative dose intensity.

The equivalent results where all treatments are costed at list price are presented in Table 22.

Table 22: ERG's preferred model assumptions (list price for all drugs)

Preferred assumption	Section in ERG report	Cumulative ICER £/QALY
Company base-case	Section 5.1.1	████
Set OS curve to joint log-logistic	Section 4.2.6.1	████
Set PFS curve to joint Weibull	Section 4.2.6.2	████
Set RDI for lenalidomide maintenance to 94.9%	Section 4.2.8.1	████

Set MRU costs post-relapse same as pre-relapse	Section 4.2.8.2	████
Halve pre-relapse outpatient visits for observation	Section 4.2.8.2	████
ERG's preferred subsequent treatment settings	Section 4.2.8.4	████
Set cost of "other" equivalent to CTD regimen	Section 4.2.8.4	████
Set cost of bortezomib from eMIT	Section 4.2.8.4	████

Key: CTD, cyclophosphamide + thalidomide + dexamethasone; eMIT, electronic market information tool; ERG, Evidence Review Group; ICER, incremental cost-effectiveness ratio; MRU, medical resource use; OS, overall survival; PFS, progression-free survival; QALY, quality adjusted life year; RDI, relative dose intensity.

A comparison of the company's base-case analysis and the ERG's preferred analysis results are presented in Table 23. The equivalent results of PSA using set of preferred assumptions are also provided. The corresponding set of deterministic results using the list price for all treatments are provided in Table 24. A comparison of the company's scenario analyses using the ERG's preferred assumptions versus the company's base case is provided in Table 25.

Table 23: Comparison of company and ERG base-case results

Arm	Total			Incremental			ICER (£/QALY)
	Costs (£)	LYs	QALYs	Costs (£)	LYs	QALYs	
Company base-case (deterministic)							
Observation	████	██	██				
Lenalidomide	████	██	██	████	██	██	████
ERG base-case (deterministic)							
Observation	████	██	██				
Lenalidomide	████	██	██	████	██	██	████
Company base-case (probabilistic)							
Observation	████	██	██				
Lenalidomide	████	██	██	████	██	██	████
ERG base-case (probabilistic)							
Observation	████	██	██				
Lenalidomide	████	██	██	████	██	██	████

Key: ERG, Evidence Review Group; ICER, incremental cost-effectiveness ratio; Lys, life years; QALYs, quality adjusted life years

Table 24: Comparison of company and ERG base-case results (list prices for all)

Arm	Total			Incremental			ICER (£/QALY)
	Costs (£)	LYs	QALYs	Costs (£)	LYs	QALYs	

Company base-case (deterministic)							
Observation	████	██	██				
Lenalidomide	████	██	██	████	██	██	████
ERG base-case (deterministic)							
Observation	████	██	██				
Lenalidomide	████	██	██	████	██	██	████

Key: ERG, Evidence Review Group; ICER, incremental cost-effectiveness ratio; Lys, life years; QALYs, quality adjusted life years

Table 25: Comparison of company and ERG scenario analysis results

Scenario	ICER (£/QALY)	
	Company	ERG
Base-case	████	████
Time horizon: 5 years	████	████
Time horizon: 10 years	████	████
Time horizon: 20 years	████	████
Hatswell utilities	████	████
Discount rate: 1.5% benefits, 6% costs	████	████
0% pts receive subsequent therapies	████	████
Include admin costs for oral therapies	████	████
Discount rate for costs: 0%	████	█
Discount rate for costs: 1.5%	████	████
Double AE rates	████	████
Cost of 'Other' treatments is zero	████	████
Cost of 'Other' treatments is doubled	████	████
Apply the post-LOE PAS to the UKCS subsequent treatments in the observation arm	████	████
77% pts receive treatment after 2nd relapse	████	████
Launch date: 1st January 2021	████	████
Launch date: 1st March 2021	████	████
Launch date: 1st June 2021	████	████
Include dara+bort+dex and ixa+len+dex	█	██████
Subsequent therapy calculation: cost per cycle	█	█
Subsequent therapy calculation: cost per cycle averaged across treatment duration	█	█
Time point for use of PFS hazard for ToT: 5 years	████	████

Scenario	ICER (£/QALY)	
	Company	ERG
Time point for use of PFS hazard for ToT: 10 years	████	████
Time point for use of PFS hazard for ToT: No constraint	████	████
Source of clinical data: CALGB	████	████

Key: AE, adverse event; ERG, Evidence Review Group; ICER, incremental cost-effectiveness ratio; LOE, loss of exclusivity; PAS, patient access scheme; PFS, progression-free survival; QALY, quality-adjusted life-year; ToT, time on treatment; UKCS, United Kingdom Clinician Survey.

Notes: *ERG notes that this scenario is not functional within the company's model. **ERG notes that the specification of a 0% discount rate for costs leads to a model error. ***No change as ERG base-case does not include option of adding or removing these options.

6.4. Conclusions of the cost-effectiveness section

The CS is aligned with the scope of this appraisal, yet the identification of evidence to inform the supporting economic model is unclear

The ERG has performed a detailed review of the evidence submitted by the company to quantify the cost-effectiveness of lenalidomide as maintenance treatment for patients with MM following ASCT. The ERG is satisfied that the company's submission is aligned with the scope set out by NICE, and includes all appropriate costs and effects that are important to consider within the context of the decision problem.

The ERG noted a number of concerns regarding the systematic reviews of economic evidence as discussed in Section 4.1. This was predominantly due to a lack of clarity in reporting particularly in respect of the documentation of the study selection process. In many cases it was also not possible to reconcile many of the discrepancies within each of the review reports (CS Appendices G, H, I). This was particularly true for the review of HRQoL and utilities (Section 4.1.2). In addition, the studies included in the review of healthcare resource use and costs were appeared to have been ignored in favour of alternative sources (Section 4.1.3). Given these limitations, the ERG had no confidence in the overall output of this review and could not confidently rule out selection bias in respect of the identification of model inputs.

The key limitation of the company's model is its inability to fully capture the costs and effects of subsequent therapies

While the ERG identified only a small number of technical errors within the company's model, the PartSA model structure used is subject to a number of important limitations, and thus the true estimate of lenalidomide's cost effectiveness may not be appropriately represented within the modelling undertaken. Most notably, the estimation of costs and effects related to

The effects of individual subsequent therapies on survival are not explicitly captured within the company's economic model, further adding to the uncertainty within the estimation of OS

The dosing regimen of lenalidomide from Myeloma XI is not aligned with the SmPC, and the impact of dose adjustments on drug costs is uncertain

The CS revolves around the expected use of lenalidomide maintenance in the UK, which is not the same dosing regimen per the SmPC. Clinical advice provided to both the company and the ERG explained that the proposed use of lenalidomide is aligned with clinical expectation. Based on the discordance between the licensed and intended usage of lenalidomide as maintenance, there is palpable uncertainty in terms of how to best reflect the use of lenalidomide within the economic model, including how to account for potential dose adjustments.

Further to the issue of dosing, the ERG is still unclear how wastage costs may be appropriately reflected through the use of RDI adjustment. This is especially important within the context of lenalidomide being an oral treatment that is non-linearly priced and is expected to be dispensed every 4 or 8 weeks (based on clinical advice provided to the ERG). In addition, the ERG considers the estimate of RDI from Myeloma XI⁷ to be lower than expected. The ERG therefore used data from another study of lenalidomide to inform its base-case analysis, though (due to the lack of clarity concerning RDI) scenarios wherein dose adjustments are removed entirely may also be appropriate to consider within decision making.

Differences in medical resource use over time are difficult to reflect within the model structure

The company's model specifies differential inputs related to medical resource use based on health state occupancy (i.e. pre- or post-progression), which is identical between treatment arms. Advice provided to the ERG suggests a potential difference in the management of patients according to whether or not patients receive lenalidomide maintenance, as well as variable course of medical resource use over time. In the ERG's preferred base-case analysis, differences in management costs between the treatment arms prior to progression were reflected. However, as all patients are grouped into a singular 'progressive disease' health state after relapse, these differences cannot be captured within the company's model.

7. END OF LIFE

In the CS, it is stated that *“although lenalidomide offers an extension to life compared to current NHS treatment options (observation), it does not qualify as a ‘life-extending treatment at the end of life’* (CS, Section B.2.13.2). The ERG agreed that given average life expectancy is notably longer than two years, NICE’s end-of-life considerations are not applicable to this appraisal and are therefore not discussed further.

References

1. Cancer Research UK. Myeloma incidence statistics, 2014–2016, 2019. Available from: <https://www.cancerresearchuk.org/health-professional/cancer-statistics/statistics-by-cancer-type/myeloma/incidence#heading-One>.
2. National Institute for Health and Care Excellence (NICE). Myeloma: diagnosis and management (NG35), 2018. Available from: <https://www.nice.org.uk/guidance/ng35>.
3. Holstein SA, Jung SH, Richardson PG, Hofmeister CC, Hurd DD, Hassoun H, et al. Updated analysis of CALGB (Alliance) 100104 assessing lenalidomide versus placebo maintenance after single autologous stem-cell transplantation for multiple myeloma: a randomised, double-blind, phase 3 trial. *Lancet Haematology*. 2017;4(9):e431–e42.
4. McCarthy PL, Owzar K, Hofmeister CC, Hurd DD, Hassoun H, Richardson PG, et al. Lenalidomide after stem-cell transplantation for multiple myeloma. *New England Journal of Medicine*. 2012;366(19):1770–81.
5. Palumbo A, Cavallo F, Gay F, Di Raimondo F, Ben Yehuda D, Petrucci MT, et al. Autologous transplantation and maintenance therapy in multiple myeloma. *New England Journal of Medicine*. 2014;371(10):895–905.
6. Attal M, Lauwers-Cances V, Marit G, Caillot D, Moreau P, Facon T, et al. Lenalidomide maintenance after stem-cell transplantation for multiple myeloma. *New England Journal of Medicine*. 2012;366(19):1782–91.
7. Jackson GH, Davies FE, Pawlyn C, Cairns DA, Striha A, Collett C, et al. Lenalidomide maintenance versus observation for patients with newly diagnosed multiple myeloma (Myeloma XI): a multicentre, open-label, randomised, phase 3 trial. *Lancet Oncology*. 2019;20(1):57–73.
8. Jackson G, Davies FE, Pawlyn C. Lenalidomide maintenance versus observation for patients with newly diagnosed multiple myeloma (Myeloma XI): open-label, randomised, phase 3 trial. Supplementary appendix. *Lancet Oncology*. 2019;20(1):57-73.
9. Tierney JF, Stewart LA, Ghersi D, Burdett S, Sydes MR. Practical methods for incorporating summary time-to-event data into meta-analysis. *Trials*. 2007;8(1):16.
10. Electronic Medicines Compendium. Revlimid (lenalidomide). Summary of product characteristics, 2020. Available from: <https://www.medicines.org.uk/emc/medicine/19841>.
11. European Medicines Agency (EMA). Summary of product characteristics. Revlimid, 2019. Available from: https://www.ema.europa.eu/en/documents/product-information/revlimid-epar-product-information_en.pdf.
12. European Medicines Agency (EMA). Summary of opinion (post authorisation). Revlimid (lenalidomide), 2017. Available from: https://www.ema.europa.eu/en/documents/smop/chmp-post-authorisation-summary-positive-opinion-revlimid-ii-89g_en.pdf.
13. Palumbo A, Cavallo F, Gay F, di Raimondo F, Yehuda DB. Autologous transplantation and maintenance therapy in multiple myeloma. Supplementary materials. Protocol. *New England Journal of Medicine*. 2014;371:895-905.
14. Abonour R, Durie BGM, Jagannath S, Shah JJ, Narang M, Terebelo H, R., et al. Health-related quality of life of patients with newly diagnosed multiple myeloma receiving any or lenalidomide maintenance after autologous stem cell transplant in the Connect® MM Disease Registry. *Blood*. 2016;128(22):537.
15. Abonour R, Wagner L, Durie BGM, Jagannath S, Narang M, Terebelo HR, et al. Impact of post-transplantation maintenance therapy on health-related quality of life in patients with multiple myeloma: data from the Connect® MM Registry. *Annals of Hematology*. 2018;97(12):2425-36.

16. Boquoi A, Giagounidis A, Goldschmidt H, Heinsch M, Rummel MJ, Kroeger N, et al. Similar quality of life with 5mg versus 25mg lenalidomide maintenance after first-line high-dose therapy and autologous blood stem cell transplantation for multiple myeloma: results of the Lenamain trial. *Blood*. 2018;132(Suppl 1):2003.
17. Acaster S, Gaugris S, Velikova G, Yong K, Lloyd AJ. Impact of the treatment-free interval on health-related quality of life in patients with multiple myeloma: a UK cross-sectional survey. *Supportive Care in Cancer*. 2013;21(2):599–607.
18. Hatswell AJ, Burns D, Baio G, Wadelin F. Frequentist and Bayesian meta-regression of health state utilities for multiple myeloma incorporating systematic review and analysis of individual patient data. *Health Economics*. 2019;28:653-65.
19. Roussel M, Hebraud B, Hulin C, Perrot A, Caillot D, Macro M, et al. The impact of lenalidomide, bortezomib, and dexamethasone treatment on health-related quality of life in transplant-eligible patients with newly-diagnosed multiple myeloma: results from the IFM/DFCI 2009 trial. *Blood*. 2018;132(Suppl 1):716.
20. Tay J, Vij R, Norkin M, Buadi F, Kindwall-Keller TL, Roberts JS, et al. Health related quality of life for multiple myeloma patients according to treatment strategy after autologous stem cell transplant: a cross-sectional study using EORTC, EQ-5D and MY-20 scales. *Leukemia & Lymphoma*. 2019;60:1275-82.
21. Ashcroft J, Judge D, Dhanasiri S, Taylor-Stokes G, Middleton C. Chart review across EU5 in MM post-ASCT patients. *International Journal of Hematologic Oncology*. 2018;7(1):ljh05.
22. Jackson G, Dutton R, Zamagni E, Hughes R, Dhanasiri S. Lenalidomide maintenance therapy post-autologous stem cell transplant: a healthcare cost-impact analysis in Europe. *Blood*. 2017;130(Suppl 1):3405.
23. Jackson G, Galinsky J, Alderson DEC, D'Souza VK, Buchanan V, Dhanasiri S, et al. Productivity losses in patients with newly diagnosed multiple myeloma following stem cell transplantation and the impact of maintenance therapy. *European Journal of Haematology*. 2019;103(4):393-401.
24. Niphadkar S, Varadarajan I, Pompa T, Hou KY, Degen K, Vazquez-Martinez M, et al. Autologous stem cell transplant: a cost effective and efficacious treatment for newly diagnosed multiple myeloma. *Blood*. 2016;128(22):2358.
25. National Institute for Health and Care Excellence (NICE). Position statement: consideration of products recommended for use in the Cancer Drugs Fund as comparators, or in a treatment sequence, in the appraisal of a new cancer product, 2019. Available from: <https://www.nice.org.uk/Media/Default/About/what-we-do/NICE-guidance/NICE-technology-appraisal-guidance/cancer-drugs-fund/CDF-comparator-position-statement.pdf>.
26. Latimer N. NICE DSU Technical Support Document 14: Survival analysis for economic evaluations alongside clinical trials - extrapolation with patient-level data. Available from: <http://nicedsu.org.uk/wp-content/uploads/2016/03/NICE-DSU-TSD-Survival-analysis.updated-March-2013.v2.pdf>.
27. Cancer Research UK. Myeloma survival statistics, 2014. Available from: <https://www.cancerresearchuk.org/health-professional/cancer-statistics/statistics-by-cancer-type/myeloma/survival#heading-Zero>.
28. Janssen B, Szende A. Population norms for the EQ-5D. In: Szende A, Janssen B, Cabases J, editors. *Self-reported population health: an international perspective based on EQ-5D*. Dordrecht: Springer Netherlands; 2014. p. 19-30.
29. National Institute for Health and Care Excellence (NICE). TA510. Daratumumab monotherapy for treating relapsed and refractory multiple myeloma, 2018. Available from: <https://www.nice.org.uk/guidance/ta510>.
30. British National Formulary (BNF). Lenalidomide, 2020. Available from: <https://bnf.nice.org.uk/medicinal-forms/lenalidomide.html>.

31. National Institute for Health and Care Excellence (NICE). TA587. Lenalidomide plus dexamethasone for previously untreated multiple myeloma, 2019. Available from: <https://www.nice.org.uk/guidance/TA587>.
32. Levy MM, Artigas A, Phillips GS, Rhodes A, Beale R, Osborn T, et al. Outcomes of the Surviving Sepsis Campaign in intensive care units in the USA and Europe: a prospective cohort study. *Lancet Infectious Diseases*. 2012;12(12):919-24.
33. National Institute for Health and Care Excellence (NICE). TA427. Pomalidomide for multiple myeloma previously treated with lenalidomide and bortezomib, 2017. Available from: <https://www.nice.org.uk/guidance/ta427>.
34. National Institute for Health and Care Excellence (NICE). TA457. Carfilzomib for previously treated multiple myeloma, 2019. Available from: <https://www.nice.org.uk/guidance/ta457>.
35. National Institute for Health and Care Excellence (NICE). Managing relapse of myeloma, 2019. Available from: <https://pathways.nice.org.uk/pathways/myeloma#path=view%3A/pathways/myeloma/managing-relapse-of-myeloma.xml&content=view-node%3Anodes-second-autologous-stem-cell-transplantation>.

National Institute for Health and Clinical Excellence

Centre for Health Technology Evaluation

Pro-forma Response

ERG report

**Lenalidomide for the maintenance treatment of newly
diagnosed multiple myeloma after autologous stem cell
transplantation [ID475]**

	Text from ERG report	Paragraph	Page	Company comment	ERG Response
1	<p>The ERG observed that while the SmPC for lenalidomide describes a dosing schedule of [REDACTED]. Thus, the dosing used in this appraisal is at variance with the SmPC.</p>	3.5.2.2.	37	<p>This is incorrect. The use of the 21/28 dosing regimen is not at variance with the label overall, even though the recommended dosage regimen for the maintenance indication in the SMPC is different to that used in Myeloma XI.</p> <p>The choice of a 1-21 out of 28-day dosage schedule for the Myeloma XI trial was driven by (i) clinician's experience and familiarity with the 1-21 day regimen (being the licensed and standard schedule) in transplant non-eligible patients in NHS practice, (ii) because the CALGB 100104 and IFM 2005-02 trials which subsequently supported the marketing authorisation for the lenalidomide maintenance indication had not yet reported, (iii) together with the need to maintain tolerability by giving patients a break from treatment for 1 week in every 4 weeks.</p> <p>It is worth noting that according to the lenalidomide label, lenalidomide can be used " in combination with melphalan and prednisone followed by lenalidomide maintenance in patients who are not eligible for transplant. The recommended starting dose is lenalidomide 10 mg orally once daily on days 1 to 21 of repeated 28-day cycles for up to 9 cycles [..]. Patients who complete 9 cycles or who are</p>	<p>This is not a factual inaccuracy. As stated in the ERG report, the ERG accept the company's rationale for the use of a 1-21 day dose, which was also supported by clinical experts to the ERG. This is, however, a change from the dose stated in the product licence. The ERG do not consider the dose that is used to treat patients who are not eligible for ASCT, and are therefore beyond the scope of this appraisal, to be relevant here.</p> <p>No change needed.</p>

	Text from ERG report	Paragraph	Page	Company comment	ERG Response
				unable to complete the combination therapy due to intolerance are treated with lenalidomide monotherapy as follows: 10 mg orally once daily on days 1 to 21 of repeated 28-day cycles given until disease progression.” This regimen is also termed ‘maintenance’ but the population of interest is the non-transplant eligible MM.	
2	The induction treatments used in the trial no longer reflect current UK practice, as other, more effective regimens are now used frequently. However, the ERG considered that the data presented were still relevant to UK practice.	1.2	10	This is incorrect. More current regimens for induction have not been shown superior to the older regimens. There are no head-to-head studies to show that bortezomib-based regimens (VTd or Vd) which are typically used for induction in the UK (as recommended in TA311) are “more effective” than CTd (this treatment was acknowledged in TA311 in 2014 as being a standard induction regimen)	This statement in the ERG report was based on clinical advice to the ERG, and on the basis that CTD is not a NICE recommended regimen. While there are no randomised trials comparing the efficacy of VCD/VTd and CTD, the ERG are aware of retrospective evidence in this population (Crusoe ED, et al. Superiority of the triple combination of bortezomib, cyclophosphamide and dexamethasone versus cyclophosphamide, thalidomide and dexamethasone in patients with newly diagnosed multiple myeloma, eligible for transplantation. Hematol Transfus Cell Ther. 2019) that demonstrates a higher response rate for VCD than CTD. The ERG therefore do not consider this to be a factual inaccuracy. As noted here, while the ERG considered the induction regimens used in the Myeloma

	Text from ERG report	Paragraph	Page	Company comment	ERG Response
					<p>XI trial to no longer reflect UK practice, the data was nevertheless considered to be generalisable to UK practice.</p> <p>No change needed.</p>
3	<p>However, while the ERG regarded that the methods used to locate evidence were appropriate, the CS arbitrarily excluded findings from two potentially relevant RCTs, CALGB 100104 and GIMEMA. The ERG extracted and presented information for relevant subgroups from these trials.</p>	1.2	10	<p>This is incorrect. The SLR did not exclude the two potential studies, however the GIMEMA study was excluded after being assessed for relevance with respect to the decision problem. Reasons for its exclusion are explained in Section B.2.1.1.3 and Appendix D Figure 1 of the CS. The CALGB data were not used in our submission model because of the dose (28/28 days) but the study was deemed suitable to validate extrapolations in the economic model in the original CS because the it had a very long follow up of up to 10 years and was deemed to be consistent with the UK pathway (see line 11, this document)</p>	<p>This is not a factual inaccuracy. The ERG's opinion is that the studies were arbitrarily excluded, as the rationale for excluding them was not pre-specified as part of the SLR protocol (as is standard procedure), and was in some cases refuted by the ERG (see Section 3.2 of the ERG report, p. 19-20).</p> <p>No change needed</p>
4	<p>The company also excluded the Gruppo Italiano Malattie EMatologiche dell'Adulto (GIMEMA)⁵ trial because the study population included both ASCT-eligible and ASCT-ineligible patients; however the ERG identified relevant data in the subgroup of ASCT-eligible patients.</p>	3.2	19		<p>No change needed.</p>
5	<p>Furthermore, while the ERG acknowledged that the treatment pathway used in the Cancer and Leukaemia Group B (CALGB) 100104 trial^{3,4} varies from UK clinical practice, the company stated that they considered data from CALGB 100104 to be sufficiently comparable to Myeloma XI⁷ (CS p.68) in</p>	3.2	19	<p>This is incorrect. CALGB was used in the appraisal. Specifically, it was used to validate longer term predictions obtained from Myeloma XI data, although model parameters were not used directly in the model because it</p>	<p>The ERG are unclear where the discrepancy is between the company response and the statement in the ERG report.</p>

	Text from ERG report	Paragraph	Page	Company comment	ERG Response
	order to use it to validate extrapolated data in their economic model.			included a 28-days lenalidomide monotherapy regimen. The CS states the relevance of CALGB 100104 for economic model validation purposes (Section Error! Reference source not found.) “ because it had the longest follow up, and importantly, it was the only other study, in addition to Myeloma XI, which replicated the UK care pathway reasonably closely for this patient population (using no consolidation, conducted in people who underwent ASCT and maintenance treatment given until progression) although still using a 28 days maintenance protocol”.	This is not a factual inaccuracy. No change needed
6	Subsequent therapies received by patients following progression were not reported in the CS, as the company stated that the therapies used in the trial are unlikely to represent current practice in the UK.	3.2.1.2.	23	This is incorrect. Data on subsequent therapies from Myeloma XI are reported in Appendix [Appendix O, Table 65, page 138]	The ERG assume that the company refer to Table 65 in Appendix P, which provides a breakdown of subsequent therapies received by patients in Myeloma XI. It is unclear from the CS and the company’s FAC response whether this table describes therapies received by the target population, or the wider Myeloma XI trial. Data are presented as percentages, with no sample size. As the company frequently presented data in the CS for the broader trial in the CS rather than the target population, presumably owing to the target population being part of an unplanned comparison,

	Text from ERG report	Paragraph	Page	Company comment	ERG Response
					<p>the ERG are uncertain that this table is relevant. As such, the ERG cannot confidently edit the report. As the ERG agree with the company that the breakdown of therapies received by patients did not reflect UK practice, and therefore was not considered within modelling, the ERG do not consider it to be necessary to edit this statement.</p> <p>No change needed.</p>
7	The use of CTD has reduced in the UK since the start of the trial, as daratumumab with bortezomib and dexamethasone is perceived to be more effective and is used more frequently.	3.2.1.4	24	This is incorrect. Daratumumab + bortezomib + dexamethasone is neither licensed for induction, nor it is reimbursed by NICE as an induction therapy and it would not be used as such.	The ERG have edited the report to clarify that the use of other induction therapies perceived to be more effective than CTD are now used more frequently in the UK (p. 24)..
8	However, the ERG considered that variation in therapies received at second- and third-line between the Myeloma XI trial and UK clinical practice may have a meaningful impact on the longer-term clinical effectiveness of lenalidomide therapy (see Section Error! Reference source not found.).	3.2.1.4	25	This is incorrect. Subsequent therapies do not have a meaningful impact on the longer term efficacy of lenalidomide per se; rather they have an impact on outcomes from treatments given after lenalidomide treatment.	<p>This is not a factual inaccuracy. The point made in the ERG report is that clinical effectiveness outcomes following treatment with lenalidomide will be affected by the subsequent therapies that patients receive.</p> <p>No change needed.</p>
9	Section B.1.10.1 of the CS provided data on Grade 1 to 5 AEs for the ASCT-eligible population of Myeloma XI. ⁷ These data were only given for the ■ participants receiving at least one dose of lenalidomide as maintenance treatment, and indicated that the most frequently reported AEs were ■	3.2.4.1	29	This is incorrect. The analysis presented in Section B1.10.1 provides AEs for ■ participants who only received at least one dose of 10mg lenalidomide monotherapy maintenance, as opposed to all patients who received at least one dose of lenalidomide maintenance,	<p>This is not a factual inaccuracy. The statement refers to the target population for the appraisal. Throughout the report, the ERG have highlighted where data from populations <i>not</i> relevant to the</p>

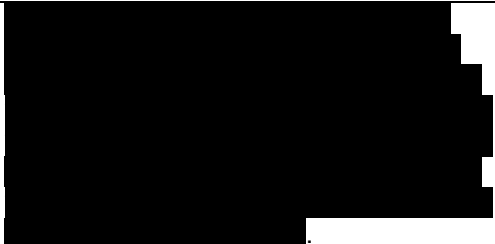
	Text from ERG report	Paragraph	Page	Company comment	ERG Response
				including patients who received 25mg lenalidomide monotherapy, as explained in Figure 4 of the CS.	decision problem (e.g. those receiving 25mg lenalidomide) were included, rather than flagging where patients who were not relevant to the decision problem were, rightly, excluded. No change needed.
10	Comparison of effect size between CALGB 100104 ^{3,4} and Myeloma XI ⁷ was limited due to differences in the duration of treatment received in each trial, and by the limitation of data reported at later timepoints for CALGB 100104 that have not been adjusted for treatment switching.	3.5.2.2.	38	This is incorrect. The CS included comparisons between CALGB and Myeloma XI based on a switch-adjusted reanalysis of data from CALGB. The switch-adjusted HR for CALGB are provided in Table C3, Appendix O, page 125.	Thank you, this is an error in the text, as the ERG report provides OS and PFS outcomes adjusted for switching in Table 9 (p. 37-38). This text has been removed (ERG report p.37). Furthermore, on inspection the ERG noted an error in the data reported in Table 9, which has now also been corrected (Table 9, p. 37-38).
11	The company excluded the GIMEMA ⁵ trial from their SLR because the study sample included both ASCT and non-ASCT patients (the latter received consolidation therapy with melphalan, prednisone and lenalidomide prior to the maintenance phase of the study).	3.5.1.	35	This is incorrect. The GIMEMA study was excluded for two reasons: <ol style="list-style-type: none"> 1. The lack of separate reporting of the ASCT + maintenance vs ASCT + no maintenance (as described by the ERG, see discussion in line 15), and not just the fact that the study sample included people who did not receive ASCT; and 2. Equally importantly, because <i>all</i> patients in the study received lenalidomide prior to stage 2 randomisation to maintenance or no maintenance, and regardless of allocation to ASCT or MPR. 	This is not a factual inaccuracy. The company primarily describe GIMEMA as not being suitable for inclusion due to the unavailability of data for the ASCT + maintenance vs ASCT + no maintenance samples. However, the ERG identified some limited data for the ASCT + maintenance vs ASCT + no maintenance groups which should be presented for completeness. Whilst the company do mention that the care pathway in GIMEMA differs from the UK

	Text from ERG report	Paragraph	Page	Company comment	ERG Response
				<p>GIMEMA is therefore not generalisable to UK practice, as explained in the CS.</p> <p>The GIMEMA study was a 2x2 factorial randomised trial, in which participants were assigned to one of 4 groups based on random allocation to stage 1 intervention (ASCT vs MPR) followed by another random allocation to a second stage intervention, maintenance vs no maintenance.</p> <p>The population was therefore allocated to one of the following groups, corresponding to the combination of factors in the sequence: 1-2: A: lenalidomide-based induction (4 cycles) + B: melphalan + ASCT +/- C: maintenance or no maintenance 3-4: A: lenalidomide-based induction (4 cycles) + B: melphalan+ prednisone + lenalidomide (MPR) +/- C: maintenance or no maintenance</p> <p>Component 'A', lenalidomide induction, was not randomised, so all participants in the study were recipients. Overall, considering 4 cycles of lenalidomide given as 'induction' and 6 cycles given as 'consolidation', patients in the 'MPR' group were exposed to treatment with lenalidomide for at least 10 cycles. Overall, there were no participants in GIMEMA who remained entirely unexposed to lenalidomide.</p>	<p>setting, the use of lenalidomide as an induction therapy is not specified as a reason for exclusion. More importantly, according to the company's inclusion and exclusion criteria for their SLR, the use of lenalidomide as an induction treatment would not be a sufficient reason to exclude the study</p> <p>No change needed.</p>

	Text from ERG report	Paragraph	Page	Company comment	ERG Response
				<p>As a reflection, any comparison between groups in GIMEMA is not a comparison between a group exposed and a group not exposed to lenalidomide (regardless of reporting) and therefore unsuitable to inform the Appraisal.</p> <p>In contrast, and precisely because of this reason, the CALGB study remains relevant for the UK, as it contains a comparison between a group exposed to lenalidomide and a group never exposed to lenalidomide.</p>	
12	<p>However, the ERG identified relevant OS and PFS data (Section Error! Reference source not found.) for the ASCT-eligible patients in the text and figures of the primary publication.⁵ The ERG acknowledge that these data are extremely limited, and that the study was not powered to investigate treatment differences in the cohort relevant to the decision problem, but these are presented for completeness.</p>	3.5.1	35	<p>This is incorrect. There is no data in the Palumbo 2014 publication that represents a group who had all received an ASCT and went on to receive lenalidomide maintenance therapy or no maintenance. This issue is a limitation of the GIMEMA data independently from whether a power calculation was done or not.</p> <p>The argument used to estimate such OS and PFS data from Figure 2A from Palumbo (2014) is based on a flawed interpretation of the GIMEMA study design as a parallel clinical trial, with two subgroups defined by ASCT status (line 13 in this document).</p> <p>Because of randomisation being conducted at study recruitment and disclosed for each stage at the time of assessment for eligibility to interventions, some patients, even if</p>	<p>This is not a factual inaccuracy. The ERG agree with the company that data presented in the Palumbo 2014 publication are unclear with regards to the timing of randomisation and the methods used for ITT analysis. However, the HR outcomes presented in the ERG report are solely from a population who <i>received</i> ASCT, as the ERG calculated these from a timepoint after which those who had not received ASCT had been censored. These data are therefore relevant to the decision problem.</p> <p>The ERG do note that the median PFS data provided in Table 8 of the ERG report (page 35) are based on an ITT sample. The methods for</p>

	Text from ERG report	Paragraph	Page	Company comment	ERG Response
				<p>randomised to receive ASCT and maintenance, did not receive them because failing to respond to induction.</p> <p>Such participants remain in the ITT analysis, in the original allocated group. The implications for the interpretation of study results (OS, PFS) are provided in line 15, this document.</p>	<p>conducting ITT analysis in this study are unclear, and therefore the ERG agree that there is a risk that this evidence includes patients who were randomised to ASCT but who did not receive it. For clarity, and to assist the committee, the ERG has amended the footnote to this table (Table 8, page 35) to highlight this.</p>
13	<p>In the first phase of the study, 273 patients were assigned to either melphalan with ASCT or to consolidation with melphalan, prednisone and lenalidomide. Of these patients, 251 went on to enter the maintenance phase of the study, 135 of whom had received an ASCT (67 were randomised to lenalidomide and 68 to no maintenance treatment).</p>	3.5.1.1	35	<p>This is incorrect. In GIMEMA, randomisation occurred at recruitment into the study, therefore, before response to MPR/ASCT which is also the criterion used to re-evaluate eligibility to maintenance.</p> <p>Randomisation to maintenance or no maintenance was disclosed once the participant reached eligibility assessment. This is different that patients being randomised at the point of receiving the ASCT.</p> <p>The Consort Flow Chart in the Palumbo publication is at variance with the text of the publication where randomisation methods are described.</p>	<p>Although the Palumbo (2014) paper is unclear, it does state that 135 patients who received an ASCT entered the maintenance phase (of whom 67 were randomised to lenalidomide and 68 to no maintenance treatment). This is not factually inaccurate.</p> <p>The timing of randomisation is contradictory in the Palumbo 2014 paper. If the company is correct that randomisation to the maintenance phase occurred at the start of the study, then it would be inaccurate to say that 273 patients were assigned to either melphalan with ASCT or to consolidation with melphalan, prednisone and lenalidomide (even though that is what Figure 1 in the Palumbo 2014 paper implies). To acknowledge that there is uncertainty in this</p>

	Text from ERG report	Paragraph	Page	Company comment	ERG Response
					number, the ERG has reworded the text on page 34.
14	The lenalidomide maintenance arm received 10mg of lenalidomide on days 1-21 of each 28-day cycle, until disease progression or discontinuation due to AEs. The comparator arm received no maintenance treatment.	3.5.1.1	35	This sentence infers a maintenance arm in GIMEMA which the study did not contemplate. Because of stage 1 and stage 2 treatment randomisation at recruitment, the 'maintenance' and 'no maintenance' groups are based on second stage randomisation to two of the four factors. The authors describe this analysis as 'maintenance analysis', as the abstraction of treatment by arm used in this manner would be incorrect.	This is not a factual inaccuracy. The ERG consider that the group of participants being referred to in the text is clear. No change needed.
15	The ERG calculated HRs for PFS and OS using the data from the ASCT-eligible cohort in GIMEMA. ⁵ Information (survival curve and numbers at risk) were extracted from figure 2A in Palumbo et al. (2014) ⁵ for the ASCT subgroups and analysed using the methods and calculator provided by Tierney et al. (2007). ⁹ In this survival curve, results are referenced to the time of diagnosis, which included an induction period of approximately 4 months, 'consolidation' of 8 months, with lenalidomide maintenance beginning within the first 3 months after completion of consolidation therapy. In order to relate to the maintenance period only, the pooled hazard ratio was therefore calculated on the basis of follow-up from the first available timepoint (18 months) since diagnosis, when all patients are thought to have entered the maintenance phase. Results of the ERG calculations are provided in Error! Reference source not found.	3.5.1.2	36	Figure 2A (OS and PFS Kaplan-Meier) in Palumbo 2014 represents overall (ITT) survival for people allocated to high dose melphalan + maintenance / high dose melphalan + no maintenance (we disregard the MPR groups in this discussion as not relevant). The ITT population included patients who did not receive an ASCT. In fact, the ITT definition for this population includes the following: <ol style="list-style-type: none"> 1. People started on lenalidomide-based induction (A, 4 cycles) at study enrolment, and 2. Proceeding to receive B: melphalan + ASCT (if responders to A) or, 3. Initially allocated to B (melphalan + ASCT) but not 	The ERG have responded to this point in items 12 and 13. The company do not appear to request any further change in this item. No change needed.

	Text from ERG report	Paragraph	Page	Company comment	ERG Response
				<p>given an ASCT because of failing induction (A);</p> <p>4. Proceeding to ASCT and successfully engrafted, proceeding to maintenance or not (C, depending on allocation)</p> <p>5. Proceeding to ASCT but failing engraftment (a rare occurrence) therefore not eligible for maintenance regardless of allocation to maintenance or no maintenance, and despite receiving the ASCT.</p> <p>As specified in the RCT publication, “patients in whom progressive disease developed during induction or consolidation therapy were treated according to local standards and remained in the trial for later outcome evaluations” (i.e are not censored for follow-up)</p> <p>Therefore, people who fall under case 3 (and 5, although rare) remain in the ITT analysis, likely surviving past the 12 months considered by the ERG as the approximate time when maintenance is started.</p> <p>This proves that the resulting OS curve includes both people with and without ASCT, despite being allocated to the ASCT +/-maintenance group. The digitisation and use of the GIMEMA</p>	

	Text from ERG report	Paragraph	Page	Company comment	ERG Response
				<p>OS curve from month 12 onwards, to estimate the effect of maintenance vs no maintenance in people who 'received an ASCT', is therefore a flawed approach.</p> <p>For PFS, we acknowledge that the method would constitute a rudimentary approximation of the real dataset, as the reason for not receiving ASCT (failure to respond) to some extent overlaps the definition of events modelled in the PFS (progression) however discrepancies remain for people who do not progress despite not reporting a response.</p> <p>Unfortunately, the consolidation population and the maintenance population were not reported separately for ASCT / MPR initial randomisation, therefore we reiterate our initial conclusion that the GIMEMA data are not reported in usable form for this Assessment.</p>	
16	As previously mentioned (Section Error! Reference source not found.), the analyses for the relevant ASCT-cohort in Myeloma XI ⁷ were not pre-planned or published. However, for GIMEMA, these subgroup analyses were pre-planned ¹³ and reported in the primary publication for the study. ⁵	3.5.3	41	<p>This is incorrect.</p> <p>The analysis of the ASCT + maintenance subgroup in Myeloma XI was pre-planned and reported separately from the non-ASCT group (See Jackson et al, 2017, Lancet and Myeloma XI protocol in appendix to the Lancet publication).</p> <p>The pre-planned analysis differs from the decision problem cohort from Myeloma XI analysed in this submission because the ASCT +</p>	<p>This is not a factual inaccuracy. The relevant cohort is the decision problem cohort which, as the company states, was not a pre-planned analysis.</p> <p>No change required.</p>

	Text from ERG report	Paragraph	Page	Company comment	ERG Response
				<p>maintenance subgroup in Myeloma XI also included a cohort of people (randomised before Amendment 5) who received maintenance with lenalidomide 25 mg (See Figure 4 in the CS).</p> <p>The GIMEMA study was a factorial trial and therefore the 4 factorial groups (ASCT / no ASCT, maintenance/ no maintenance) did not form the basis for the powered comparisons in the study. The study was powered on stage 1 randomisation (consolidation) and stage 2 randomisation (regardless of randomisation 1).</p>	
17	The company's economic model considered the population specified in the final scope issued by NICE (consistent with the marketing authorisation for lenalidomide): adult patients with newly-diagnosed MM who have undergone an ASCT. As discussed in Section Error! Reference source not found. , this population was not pre-specified in the Myeloma XI ⁷ trial, but is aligned with the population expected to be treated with lenalidomide maintenance in NHS practice.	Section 4.2.3	56	<p>This is incorrect. The ASCT population was pre-specified as part of the randomisation sequence in Myeloma XI.</p> <p>The analysis of patients who received lenalidomide maintenance therapy (10mg) as a result of protocol amendment (dose reduction from 25mg) was not pre-specified.</p>	<p>This is not a factual inaccuracy, for the reasons outlined above (item 16).</p> <p>No change required.</p>
18	The ERG noted that the company also provided evidence from the CALGB 100104 ^{3,4} study to inform model selection. While these data may be helpful in terms of understanding how the pattern of survival may change over time, they are subject to a number of important limitations	4.2.6.1	63	The availability of CALGB as a source of data to assess the external validity of Myeloma XI extrapolations should be considered a strength of the evidence base. However, when assessing the concordance between Myeloma XI and CALGB, all aspects of the similarity should be used jointly, and over the duration of each of the two studies. Therefore, concordance over the shorter period (5 years)	<p>The company do not appear to have proposed a factual inaccuracy here. The ERG detailed several important limitations of the CALGB data in the ERG report (Section 4.2.6.1, Pages 61-64).</p> <p>No change required.</p>

	Text from ERG report	Paragraph	Page	Company comment	ERG Response
				<p>between the two studies should be considered jointly with the strength of demonstration of proportional hazard holding in CALGB over a longer period compared with Myeloma XI, suggesting that the same relationship applied in the short term should hold in the long term. Therefore, the validation of longer term predicted outcomes with Myeloma XI should not be assumed to diverge from that of CALGB if proportional hazards are inferred from CALGB and applied to Myeloma XI. The validity of CALGB as an external source of validation, and the relative merit of this study compared with other sources, should be assessed during technical engagement.</p>	
19	<p>Importantly, while evidence in support of a constant treatment effect is available based on the observed period of data collection from Myeloma XI and CALGB 100104, there is relatively little evidence available to support the expectation of a continued treatment effect (whether that is constant or consistently improving) for the remainder of the model time horizon. It may therefore also be appropriate to consider sensitivity analyses including a potential treatment waning effect. This is explored further within the ERG's exploratory analyses (Section Error! Reference source not found.).</p>	4.2.6.1	67	<p>The idea of waning of treatment effect needs to be supported by evidence of such dynamic. The therapeutic aim for maintenance with lenalidomide is to prolong remission, not to treat the disease. Therefore, maintenance should be given continuously until disease progression or intolerance, as per license.</p> <p>As the time when disease no longer responds to maintenance, patients' progressions are captured in progression-free survival, as per observed data.</p> <p>Therefore, we do not believe that treatment effect with maintenance requires an 'adjustment' because the concept of 'waning' treatment effect is not an accurate description for the</p>	<p>This is not a factual inaccuracy. As highlighted in the ERG report, there is relatively little available evidence to support the continued prolonging of remission with lenalidomide. Assuming the use of lenalidomide maintains the same level of effect on remission for the duration of a patient's lifetime may be optimistic. The ERG therefore maintain that it may be appropriate to consider sensitivity analyses which incorporate a potential reduction or tapering in the duration of remission seen in patients</p>

	Text from ERG report	Paragraph	Page	Company comment	ERG Response
				clinical evolution of MM in the appraisal population.	receiving lenalidomide maintenance. No change required.
20	Furthermore, it remained unclear to the ERG why the RDI estimate from Myeloma XI (████) is noticeably smaller than the estimate of RDI from the TMM1 clinical trial (in the relapsed/ refractory MM population) of 94.9%, given that patients in Myeloma XI received a lower target dose (10 mg versus 25 mg daily on Days 1–21, repeating every 28-day cycle).	4.2.8.1	72	The RDI observed in the TMM1 study pertained to drug treatment in a population with advanced MM, with the treatment aim of controlling the disease (relapsed refractory MM after first progression) rather than prolonging response; it is relative to a different dose (25mg) and therefore it does not apply to the current appraisal. The estimate provided in the CS is obtained from treatment data from the Myeloma XI study. The evidence basis for the RDI estimates should be discussed during technical engagement.	This is not a factual inaccuracy. While the ERG acknowledge that in the TMM1 trial, lenalidomide is used in a different (later) line of therapy; the ERG make the point that it is nevertheless unclear as to why the RDI estimate from Myeloma XI is considerably smaller than the estimate used in the TMM1 when this was delivered at a higher dose (10 mg versus 25 mg). Further issues relating to RDI are detailed in Section 4.2.8.1 (Pages 73-74) of the ERG report. No change required
21	Carfilzomib (+ dexamethasone) cannot be used in the majority of patients after SCT, as induction regimens typically include the use of bortezomib. NICE TA457 ³⁴ guidance states that carfilzomib is recommended only for patients that have not previously received bortezomib. However, assuming all patients are managed per current practice, no patients would be eligible for carfilzomib after relapse and therefore the ERG does not consider this option to be relevant for inclusion within the model.	Table 18, 4.2.8.4	79-80	We agree that in the spirit of current guidance, most people in the model would not be eligible to receive carfilzomib. It is our understanding that the stipulation r.e. carfilzomib being made available only to patients not having previously received bortezomib may be removed from guidance. Based on clinical advice, the only opportunity to use carfilzomib is in second line, given that ixazomib is recommended in third and fourth line [TA505].	This is not a factual inaccuracy. No change required.

	Text from ERG report	Paragraph	Page	Company comment	ERG Response
22	<p>However, the company's base-case does not include the option for a second SCT, as the original values included the option for daratumumab.</p> <p>A second ASCT is expected to be an option for patients after first relapse (in the absence of a daratumumab-based regimen being available), most notably for lenalidomide maintenance patients who are expected to have experienced a relatively longer period of remission.</p>	4.2.8.4	80	<p>This is incorrect. The survey of subsequent therapies included in the CS did include an option 'other' which clinicians partly specified. No clinician mentioned second ASCT as an option.</p> <p>The evidence base of this option should be a discussion point during technical engagement.</p>	<p>This is not a factual inaccuracy. The survey of subsequent therapies provided to clinicians by the company included the option for the CDF drug daratumumab. Where daratumumab is available, it is unlikely that patients would receive a second ASCT after first relapse. However, following the removal of CDF drugs from the CS (as is required by the NICE process), a survey of subsequent therapies was not redistributed to clinicians to determine which treatments would be used if CDF drugs were unavailable.</p> <p>Expert clinical opinion expressed to the ERG that in a scenario where daratumumab could not be used, a proportion of patients would be expected to receive a second ASCT.</p> <p>No change required.</p>
23	<p>Use of lenalidomide for observation patients after the first relapse may be higher than the estimate included in the company's base-case, due to a lack of other options (given that bortezomib is expected to be used as induction).</p>	4.2.8.4	81	<p>The use of lenalidomide in ASCT-eligible patients after first progression (second line) is not within NICE's reimbursement recommendations. Lenalidomide in second line is only reimbursed for patient who are not eligible for ASCT [TA586]. The guidance states in section 3.1: "The committee understood that the population relevant to this appraisal</p>	<p>In the company base-case, 7.3% of observation patients are assigned treatment with lenalidomide + dexamethasone following first relapse. The ERG has followed the suggested use of lenalidomide in this setting however, adjusted the relative market share in accordance with expert clinical advice provided to</p>

	Text from ERG report	Paragraph	Page	Company comment	ERG Response
				includes people for whom neither a stem cell transplant [...] is suitable"; and "It agreed that the relevant population includes people who cannot have a stem cell transplant". Lenalidomide is reimbursed in ASCT-eligible people only from third and subsequent lines [TA171].	the ERG. As such, if the use of lenalidomide is not recommended at the second line for ASCT eligible patients, the company's base-case is also subject to the same issue. No change required.
24	<p>There is no evidence to suggest a difference in the proportion of patients that would receive any subsequent treatment based on whether or not a patient was managed with lenalidomide maintenance or not (except that patients who have previously received lenalidomide would not receive another lenalidomide-containing regimen).</p> <p>The same proportion of patients are expected to receive any treatment across both arms, but this is expected to be higher after the first relapse compared to after the second relapse.</p>	4.2.8.4	80-81	The evidence base of this option should be a discussion point during technical engagement.	<p>The company do not appear to raise a factual inaccuracy here.</p> <p>No change required.</p>
25	Through inspection of the values reported above, it can be ascertained that for every ■ months a lenalidomide patients receives subsequent therapy after relapse, an observation patient is assumed to be treated for approximately ■ months. The ERG did not consider this difference in estimated post-progression treatment duration to be fully justified.	4.2.8.4	82	The evidence base of this option should be a discussion point during technical engagement.	<p>This is not a factual inaccuracy.</p> <p>No change required.</p>

NATIONAL INSTITUTE FOR HEALTH AND CARE EXCELLENCE

Technical report

Lenalidomide for the maintenance treatment of multiple myeloma after autologous stem cell transplant

This document is the technical report for this appraisal. It has been prepared by the technical team with input from the lead team and chair of the appraisal committee.

The technical report and stakeholder's responses to it are used by the appraisal committee to help it make decisions at the appraisal committee meeting. Usually, only unresolved or uncertain key issues will be discussed at the appraisal committee meeting.

The technical report includes:

- topic background based on the company's submission
- a commentary on the evidence received and written statements
- technical judgements on the evidence by the technical team
- reflections on NICE's structured decision-making framework.

This report is based on:

- the evidence and views submitted by the company, consultees and their nominated clinical experts and patient experts and
- the evidence review group (ERG) report.

The technical report should be read with the full supporting documents for this appraisal.

Technical report – Lenalidomide for the maintenance treatment of multiple myeloma after autologous stem cell transplant Page 1 of 36

Issue date: June 2020

© NICE 2020. All rights reserved. Subject to [Notice of rights](#).

1. Topic background

1.1 Disease background: multiple myeloma

- Type of blood cancer caused by proliferation of plasma cells (a type of white blood cell) in the bone marrow
- Myeloma cells suppress development of normal blood cells that are responsible for:
 - fighting infection (white blood cells)
 - carrying oxygen around the body (red blood cells)
 - blood clotting (platelets)
- Symptoms and complications include bone pain, bone fractures, tiredness (due to anaemia), infections, hypercalcaemia (too much calcium in the blood) and kidney problems
- In 2017, 5,034 people were diagnosed with multiple myeloma in England
- More common in older people – median age of diagnosis = 73 years
- More common in men than women
- 5-year survival rate is about 52%, while 10-year survival is about 29%

1.2 Disease background: progression of disease

- Characterised by cycles of remission and response
- As number of lines of therapy increases, time in remission decreases
- Therapy aims to prolong disease-free remission by suppressing residual disease, prolong survival, and maintain quality of life by controlling the disease and relieving symptoms

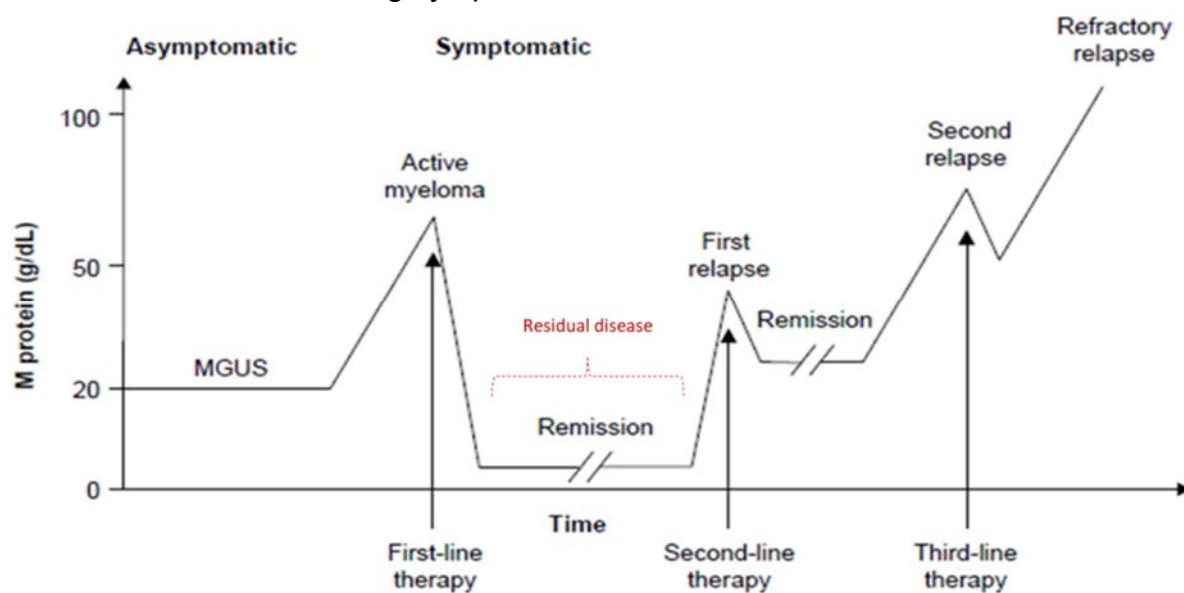

Technical report – Lenalidomide for the maintenance treatment of multiple myeloma after autologous stem cell transplant Page 2 of 36

Issue date: June 2020

© NICE 2020. All rights reserved. Subject to [Notice of rights](#).

1.3 Management of newly diagnosed multiple myeloma

- 25–30% of newly diagnosed people receive autologous stem cell transplant (ASCT)
- Eligibility for ASCT assessed by age, performance status, comorbidities
- Eligible people typically receive:
 - induction with a 3-drug regimen (e.g. bortezomib, thalidomide, dexamethasone [TA311])
 - high dose therapy (usually melphalan chemotherapy)
 - ASCT
- After ASCT, healthcare professionals monitor people but do not offer further active therapy until first relapse occurs
 - **Lenalidomide is being evaluated at this point as an active therapy**

1.4 Existing treatment pathway in multiple myeloma

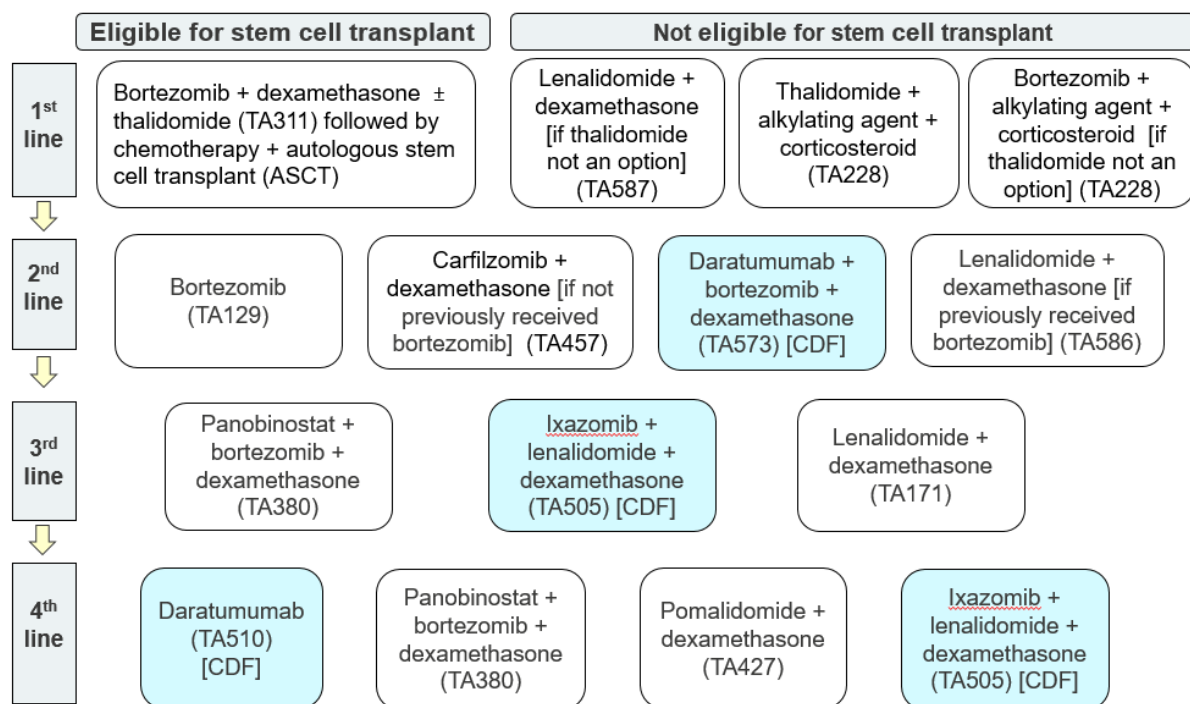

1.5 NICE recommended treatment pathway: transplant eligible

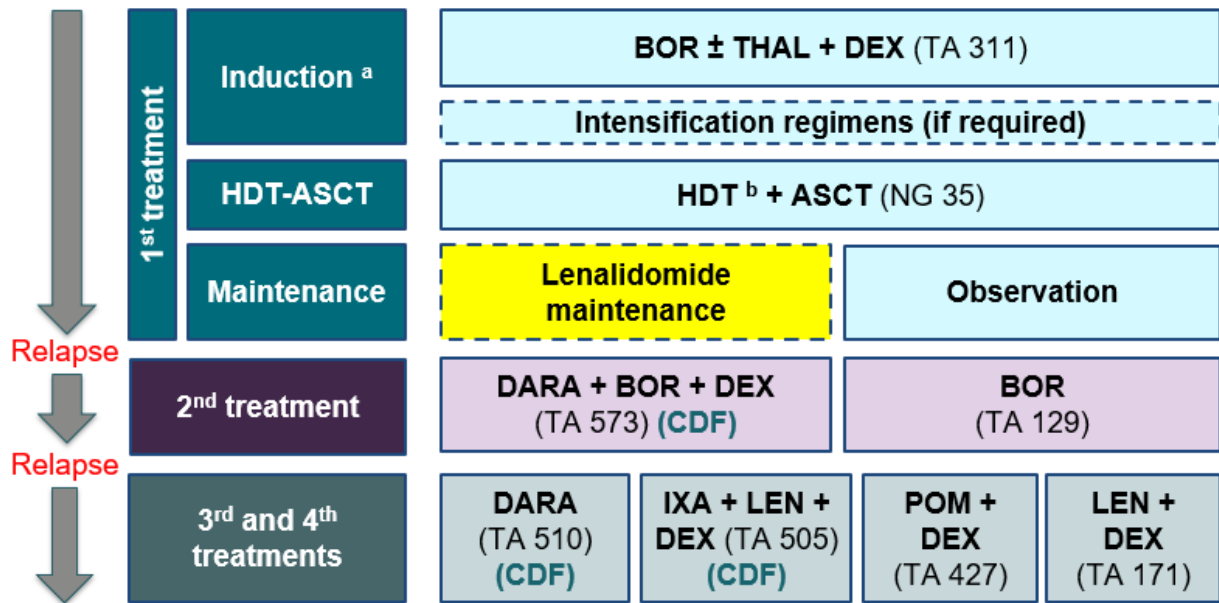

Only includes NICE-recommended therapies. ^a Induction therapies in Myeloma XI trial differed vs NICE recommendations; ^b NHS treatment algorithm recommends high dose melphalan. ASCT, autologous stem cell transplant; BOR, bortezomib; CDF, cancer drugs fund; DARA, daratumumab; DEX, dexamethasone; HDT, high-dose therapy; IXA, ixazomib; POM, pomalidomide; THAL, thalidomide. Also see: [NICE Pathway, Myeloma](#).

1.6 Lenalidomide (Revlimid, Celgene)

Marketing authorisation	<i>“Revlimid as monotherapy is indicated for the maintenance treatment of adult patients with newly diagnosed multiple myeloma who have undergone autologous stem cell transplantation”</i> (EMA license granted in 2017)
Administration and licensed dose	<ul style="list-style-type: none"> Oral treatment (capsules) 10mg once daily continuously (on days 1 to 28 of repeated 28-day cycles) given until disease progression or intolerance Increased to 15mg orally if tolerated after 3 cycles 10mg once daily on days 1 to 21 of repeated 28-day cycles likely to be used in clinical practice – differs from SmPC (see Issue 1)
Mechanism of action	<ul style="list-style-type: none"> Oral immunomodulatory imide drug (IMiD) Based on the chemical structure of thalidomide Inhibits proliferation of certain haematopoietic tumour cells and production of proinflammatory cytokines, and enhances T cell- and Natural Killer cell-mediated immunity
List price	Price per 21-tablet pack: 10 mg = £3780.00 ; 15 mg = £3969.00 ^a
Tests	Pregnancy tests at initiation and every 4 weeks during ^b

^a Price in model is lower as it includes patient access scheme discount; ^b Modelled population have an average baseline age of 59 and are predominantly male so costs of pregnancy tests were excluded. Model used Myeloma XI trial dosing (10 mg/day given on days 1–21 of a 28-day cycle) to align with anticipated clinical practice. Source: company document B, Table 2.

Technical report – Lenalidomide for the maintenance treatment of multiple myeloma after autologous stem cell transplant Page 4 of 36

Issue date: June 2020

© NICE 2020. All rights reserved. Subject to [Notice of rights](#).

1.7 Decision problem

	Final scope	Company submission	Differences from the final scope
Population	People with newly diagnosed multiple myeloma who have had ASCT		N/A
Intervention	Lenalidomide		Dosing in lenalidomide trial and company's model different versus SmPC ^a
Comparator	Established clinical management without lenalidomide maintenance, including monitoring and follow up		N/A
Outcomes	<ul style="list-style-type: none"> Overall survival Progression-free survival Time to relapse or progression Adverse effects of treatment HRQoL 		<ul style="list-style-type: none"> Time to relapse or progression provided at clarification HRQoL not collected in lenalidomide clinical trial

^a SmPC = 10mg/day on days 1 to 28 of 28-day cycles, anticipated clinical practice and Myeloma X trial = 10mg/day on days 1 to 21 of 28-day cycles (see Issue 1). ASCT, autologous stem cell transplant; HRQoL, health-related quality of life; SmPC, summary of product characteristics. Sources: company document B, Table 10 and ERG report, Table 3.

1.8 Summary of trials of lenalidomide as maintenance therapy

	Myeloma XI	CALGB 100104	GIMEMA	IFM 2005-02
Countries	UK	USA	Italy, Israel	France, Belgium, Switzerland
N	████	460	273	614
Comparator	Placebo	Placebo	Placebo	Placebo
Dosing (days per 28-day cycle)	1–21	1–28	1–21	1–28
Consolidation therapy allowed?^a	No	No	Yes	No
Used for EMA regulatory approval?	No	Yes	No	Yes
Presented as clinical evidence?^b	Yes	No	No	No
Used in model?	Yes	No	No	No

^a Consolidation therapy is not used in standard NHS practice; ^b In its submission the company only presents Myeloma XI data as clinical evidence (see Issue 2). EMA, European Medicines Agency.

Technical report – Lenalidomide for the maintenance treatment of multiple myeloma after autologous stem cell transplant Page 5 of 36

Issue date: June 2020

© NICE 2020. All rights reserved. Subject to [Notice of rights](#).

1.9 Myeloma XI: trial overview

- Phase 3, UK, multicentre, open-label, adaptive-design, randomised trial
- UK study (110 NHS centres)
- Population: newly diagnosed patients stratified by eligibility for ASCT
- Company submission focused on the cohort relevant to the decision problem:
 - eligible for ASCT
 - completed randomised induction and achieved a maximum response to induction therapy
 - subsequently randomised to maintenance with lenalidomide 10 mg or observation
- Trial used to support application for marketing authorisation? **NO**
- Trial used in economic model? **YES**

1.10 Myeloma XI: design, decision problem cohort

Phase 3, UK, multicentre, open-label, adaptive-design, randomised trial

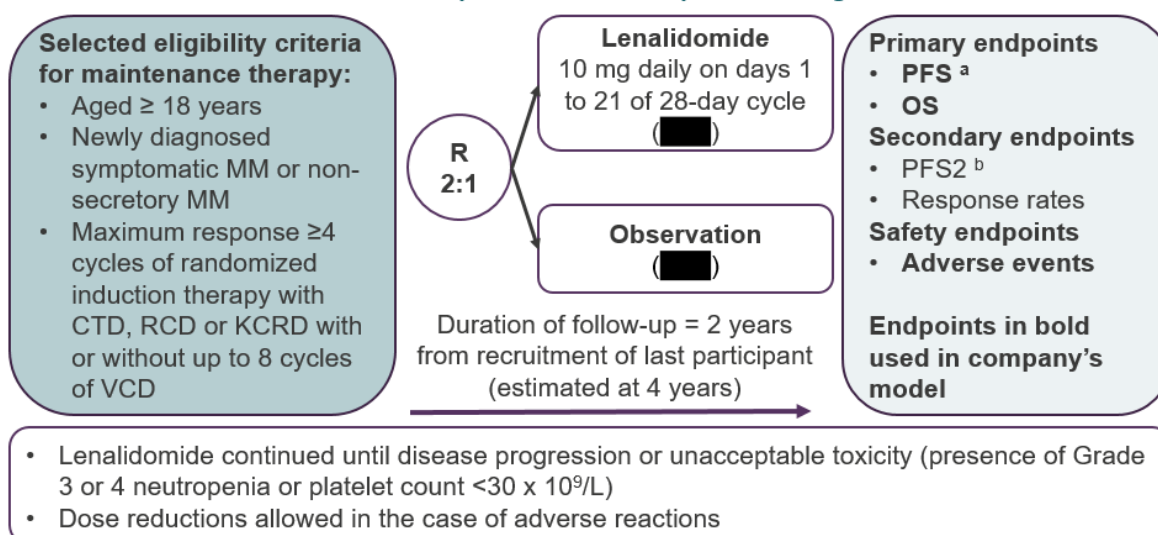

^a Time from maintenance randomisation to progressive disease or death from any cause; ^b Time from maintenance randomisation to the date of second progression, start of third antimyeloma treatment or death from any cause (whichever was first). CTD, cyclophosphamide, thalidomide and dexamethasone; KCRD, carfilzomib, lenalidomide, cyclophosphamide and dexamethasone; RCD, lenalidomide, cyclophosphamide and dexamethasone; MM, multiple myeloma; OS, overall survival; PFS, progression-free survival; VCD, bortezomib, cyclophosphamide and dexamethasone. Source: company document B, pages 31 to 41.

1.11 Myeloma XI: clinical efficacy results for the decision problem cohort

	Lenalidomide [REDACTED]	Observation [REDACTED]	HR (95% CI)
Primary outcome: progression-free survival			
Median, months (95% CI)	[REDACTED]	[REDACTED]	[REDACTED]
Events	[REDACTED]	[REDACTED]	–
Censored	[REDACTED]	[REDACTED]	–
Primary outcome: overall survival			
Median, months (95% CI)	[REDACTED]	[REDACTED]	[REDACTED]
Events	[REDACTED]	[REDACTED]	–
Censored	[REDACTED]	[REDACTED]	–

CI, confidence interval; HR, hazard ratio; NA, not applicable; NR, not reached. Source: company document B, pages 47 and 48.

1.12 Myeloma XI: Kaplan–Meier plot for progression-free survival

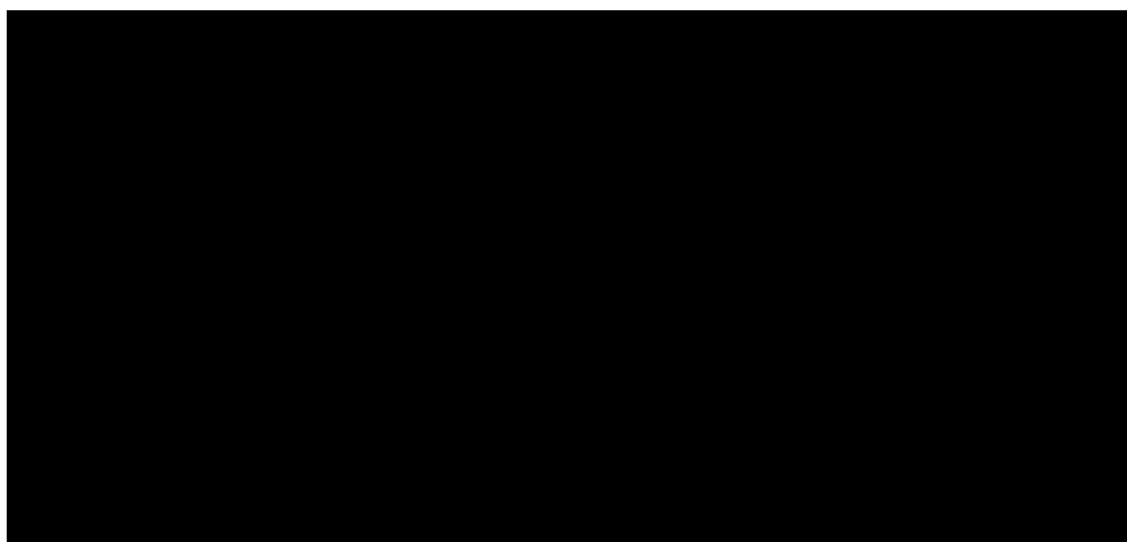

PFS, progression-free survival. Source: company document B, page 49.

1.13 **Myeloma XI: Kaplan–Meier plot for overall survival**

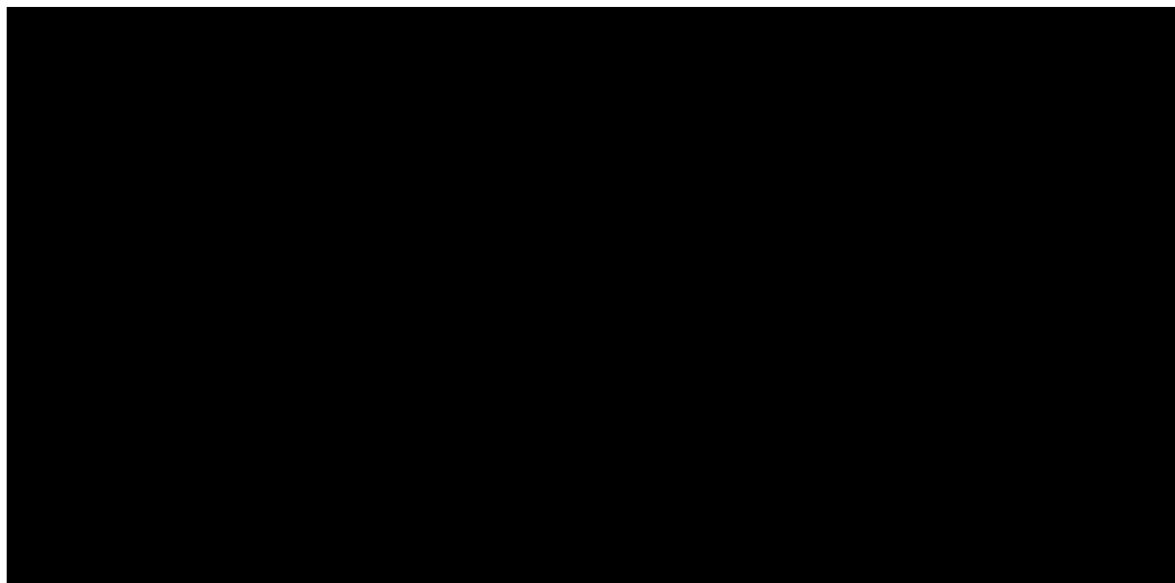

OS, overall survival. Source: company document B, page 50.

1.14 **Myeloma XI: adverse events in the decision problem cohort**

- Analysis based on safety population: ^a [REDACTED]
- No safety data were provided for the observation arm

Most frequently reported adverse events in lenalidomide group

	Grade 1 or 2 n (%)	Grade 3 n (%)	Grade 4 n (%)	Grade 5 n (%)
[REDACTED]	[REDACTED]	[REDACTED]	[REDACTED]	[REDACTED]
[REDACTED]	[REDACTED]	[REDACTED]	[REDACTED]	[REDACTED]
[REDACTED]	[REDACTED]	[REDACTED]	[REDACTED]	[REDACTED]
[REDACTED]	[REDACTED]	[REDACTED]	[REDACTED]	[REDACTED]
[REDACTED]	[REDACTED]	[REDACTED]	[REDACTED]	[REDACTED]
[REDACTED]	[REDACTED]	[REDACTED]	[REDACTED]	[REDACTED]
[REDACTED]	[REDACTED]	[REDACTED]	[REDACTED]	[REDACTED]
[REDACTED]	[REDACTED]	[REDACTED]	[REDACTED]	[REDACTED]

^a People who received at least one dose of 10 mg lenalidomide maintenance. Source: company document B, Table 16.

1.15 Meta-analysis, indirect and mixed treatment comparison

- Company did not perform meta-analysis, indirect or mixed treatment comparison of lenalidomide trials (CALGB 100104, IFM 2005-02, GIMEMA and Myeloma XI, all versus placebo) because of what it considered a high degree of heterogeneity between the trials.

1.16 Company's model structure

- Partitioned survival analysis model comprised of 3 health states: pre-progression, progressive disease, and death
- Cycle length: 28 days
- Time horizon: lifetime

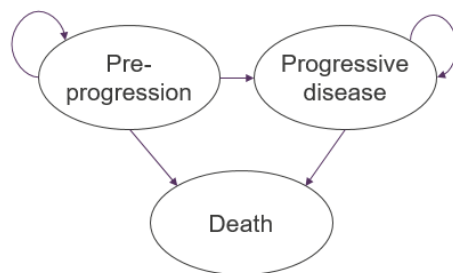

Determining state membership

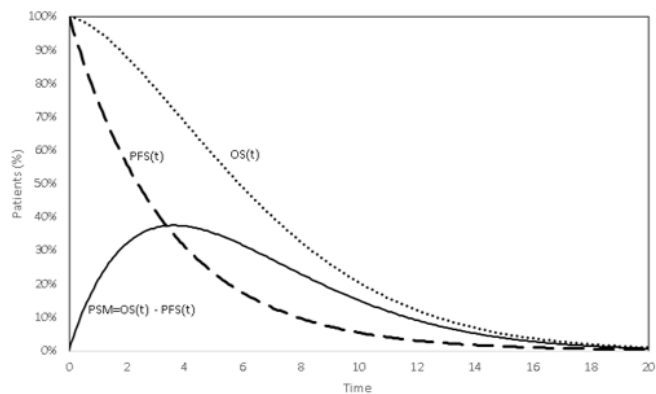

1.17 Company's assumptions for its base case model

Assumption	Company's justification
Survival extrapolations based on Myeloma XI data	
Overall survival: independent (not 'joint') models to extrapolate <ul style="list-style-type: none"> • Lenalidomide: log-logistic • Observation: Weibull 	<ul style="list-style-type: none"> • Log-cumulative hazard plots did not provide evidence for proportional hazards • When joint modelling generated plausible curves, company did not pursue independent modelling • Company compared its model to longer-term follow-up from CALGB 100101 trial to establish appropriate distribution for each model arm
PFS: joint model to extrapolate <ul style="list-style-type: none"> • Exponential 	
Adverse events	
Included AEs: Grade 3 or greater occurring in $\geq 2\%$ of patients	Company considered only AEs expected to affect cost. Utility decrements for these AEs were applied
AEs only applied in treatment arm	No active treatment is used in the observation arm
Utility values	
Utilities depend on health state and are equal between arms	There are no data that show evidence for a lenalidomide-specific utility benefit
Resource use and costs	
Medical resource differs by health state but is the same for both arms	Absence of other data
AE costs were not included for subsequent therapies	Simplifying assumption, lack of data

1.18 Overview of how quality-adjusted life years accrue in the model

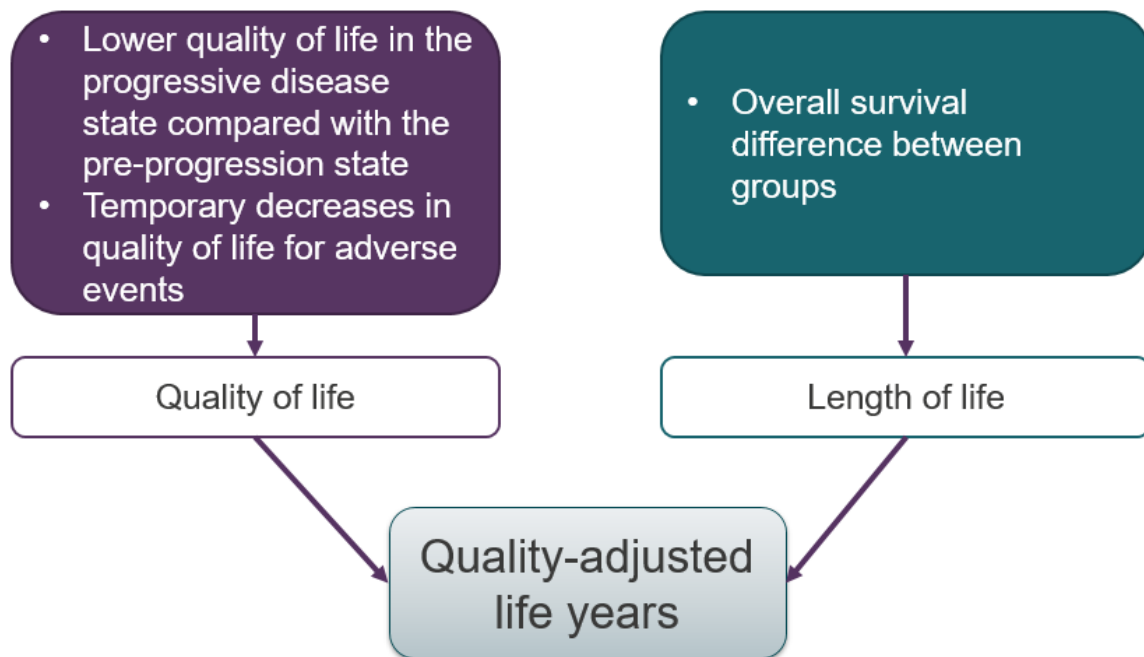

2. Summary of the technical report

2.1 In summary, the technical team considered the following:

Issue 1 The lenalidomide regimen in the company submission is not aligned with the marketing authorisation

Issue 2 The company excluded evidence from potentially relevant clinical trials

Issue 3 The company did not present adverse event data for the observation arm of the target population from Myeloma XI

Issue 4 Concerns with the company's systematic review of economic evidence

Issue 5 The company's method for estimating subsequent treatment costs may not be appropriate

Issue 6 The company provided highly uncertain estimates of overall survival, and the company and ERG disagree on which distribution to use for extrapolation

Issue 7 Uncertain impact of dose adjustments and wastage on drug costs

Issue 8 Whether medical resource use should differ between treatments and between relapse status

2.2 The technical team recognised that the following uncertainties would remain in the analyses and could not be resolved:

- The company's partitioned survival analysis model structure may be overly simple because it prevents alternative assumptions surrounding subsequent therapies being fully explored
- Clinical evidence in the company submission is from an unplanned analysis of a subpopulation from the wider Myeloma XI trial
- Induction treatments used in the Myeloma XI trial may no longer reflect current NHS practice

- 2.3 The cost-effectiveness results include a confidential patient access scheme for lenalidomide.
- 2.4 The company's deterministic base case incremental cost-effectiveness ratio (ICER) was █████ per QALY gained, while the ERG's preferred ICER was █████ (see [Table 1: Impact of ERG's preferred assumptions on the cost-effectiveness estimate](#)).
- 2.5 Based on the modelling assumptions, the intervention is not likely to meet the end-of-life criteria because the average life expectancy of the population under consideration is over 2 years.
- 2.6 The company considers the technology to be innovative because it represents a step-change in the management of transplant-eligible newly diagnosed multiple myeloma. However, the technical team consider all benefits have been captured in the cost-effectiveness estimate.
- 2.7 No equality issues were identified.

3. Key issues for consideration

Issue 1 – The lenalidomide regimen in the company submission is not aligned with the marketing authorisation

Background/description of issue	<p>The summary of product characteristics for lenalidomide states that it should be taken once daily continuously on days 1 to 28 of repeated 28-day cycles. However, in the Myeloma XI trial upon which the company bases its submission, lenalidomide was given on days 1 to 21 of a 28-day cycle.</p> <p>The company states that 21 days of dosing over a 28-day cycle was used in Myeloma XI because lenalidomide was not licensed for maintenance therapy following ASCT at the time of the trial. It therefore used the same dosing schedule as for the population not eligible for ASCT. The company considers that clinicians and patients will prefer 21 days of dosing per cycle because clinicians are used to this schedule, and there may be safety benefits associated with giving patients a treatment free week (see response to clarification question A6).</p> <p>Although dose escalation to 15 mg per day is allowed according to the summary of product characteristics, it was not allowed in the Myeloma XI trial. The company did not include dose escalation in its model.</p> <p>Clinical advisers to the ERG confirmed that the company's assumptions that 21 days of treatment per 28-day cycle is appropriate and aligned with how it would be used in NHS clinical practice for this indication. Furthermore, the 7-day break in treatment is likely to prolong treatment duration and dose escalations are unlikely to happen in clinical practice (see ERG report sections 3.6 and 4.2.4).</p> <p>The ERG conducted an exploratory analysis in which it used CALGB 10014 trial data and costs to reflect a 28-day dosing schedule; this resulted in the company's base case ICER reducing to [REDACTED] per QALY gained.</p>
--	--

Why this issue is important	Dosing may have important effects on the efficacy, safety, and cost-effectiveness of lenalidomide. It is important to understand the clinical and cost effectiveness of the dosing schedule that is most likely to be used in the NHS and which is based in evidence.
Technical team preliminary judgement and rationale	The company's assumption that lenalidomide will be given on days 1 to 21 of a 28-day cycle in NHS practice appears to be appropriate. However, the ERG's exploratory analysis of a 28-day dosing schedule is important to consider as a scenario.
Questions for engagement	<ul style="list-style-type: none"> a) What dosing schedule would be used in clinical practice for maintenance therapy with lenalidomide following ASCT: 1 to 21 days or 1 to 28 days of a 28-day cycle? b) Is lenalidomide likely to be as effective and safe over 1 to 21 days as it is over 1 to 28 days of a 28-day cycle? c) If a 1 to 28-day dosing schedule is used a) are the results of the Myeloma XI trial generalisable to clinical practice in the NHS, and b) are there any implications for drug wastage? d) What proportion of patients are likely to escalate their dose to 15 mg once daily in clinical practice?

Issue 2 – The company excluded evidence from potentially relevant clinical trials

<p>Background/description of issue</p>	<p>Of 4 studies identified in the company’s systematic literature review, only 1 (Myeloma XI) is presented in detail by the company in its submission and provides the primary source of clinical effectiveness data for the economic model.</p> <p>The company identified 4 trials of lenalidomide maintenance therapy as part of their systematic literature review: Myeloma XI, CALGB 100104, GIMEMA, and IFM 2005-02. It states that Myeloma XI is the only trial that accurately reflects the decision problem and current UK clinical practice. Myeloma XI was the only trial conducted in the UK, was powered for detecting differences in survival, did not include consolidation therapy post-ASCT and used a dosing schedule aligned with NHS clinical practice (21 days of a 28-day cycle). See section B.2.1 of company submission for more information. Although the company excluded CALGB 100104 from the clinical evidence, it deemed it to be suitable for validation of survival curve extrapolations for the economic model (see Issue 4).</p> <p>The ERG regarded the methods used to retrieve evidence as being appropriate but disagreed with the company’s rationale for excluding trials. The ERG note that the company did not pre-specify its criteria to exclude trials as part of its literature review protocol, and the company’s rationale for excluding trials seemed arbitrary. It considered that although IFM 2005-02 should be excluded because it is not applicable to UK practice, the CALGB 100104 and GIMEMA trials met the company’s inclusion criteria (see Section 3.2 of the ERG report).</p> <p>Note that a comparison of clinical efficacy results between Myeloma XI and GIMEMA and CALGB 100104 can be found in the company submission (section B.2.13.1, Table 17) and in the ERG report (Tables 8 and 9). Both the company and ERG agreed that heterogeneity between these and the Myeloma XI trial and the paucity of data meant a meta-analysis was not feasible.</p>
<p>Why this issue is important</p>	<p>Any potential arbitrary exclusion of clinical evidence may increase bias. It is important for the committee to assess the entire evidence base relevant to the decision problem.</p>

Technical team preliminary judgement and rationale	The CALGB 100104 and GIMEMA trial results should be considered during committee decision making, while acknowledging that they have limited generalisability to the population under consideration. It was appropriate for the company to: a) not synthesise the evidence from the Myeloma XI, CALGB 100104 and GIMEMA trials, and b) only use Myeloma XI data in the economic model because it uses the dosing regimen likely to be used in clinical practice and was conducted in the UK.
Questions for engagement	<ul style="list-style-type: none"> a) Are the CALGB 100104 and GIMEMA trials, which both use the dosing schedule in the marketing authorisation, relevant to the decision problem and should the results be considered by the committee? b) Is it appropriate to synthesise data from Myeloma XI, CALGB 100104 and GIMEMA (for example, in a network meta-analysis)? c) Should CALGB 100104 and GIMEMA trial data be used in the economic model?

Issue 3 – The company did not present adverse event data for the observation arm of the target population from Myeloma XI

<p>Background/description of issue</p>	<p>In its submission the company presented adverse event data for people in the decision problem cohort of the Myeloma XI trial who received at least one dose of lenalidomide maintenance therapy (see B.2.10.1 of company submission document B). It stated that no safety data were available for the observation arm of this cohort. Similarly, for the intention-to-treat population of the trial which contained people who were both ASCT-eligible and ineligible, the company presented adverse event data for the lenalidomide arm but not the observation arm. The company only presented serious adverse events in the intention-to-treat population for people in the observation arm; therefore, this is the only data that allowed between-arm comparisons to be made.</p> <p>The ERG is concerned that the lack of observation arm data prevents meaningful comparisons being made for the decision problem cohort. It acknowledges that observation arm data were available for serious adverse events in the intention-to-treat population, however it is unclear to what extent this can be generalised to serious adverse events in the decision problem cohort. Overall, the ERG concluded that although it is unlikely lenalidomide would have an unacceptable rate of serious adverse events, the risks associated with lenalidomide maintenance in the population of interest remains unclear (see sections 3.2.4.1 and 3.6 of ERG report). In its report, the ERG presented additional data from the CALGB 100104 trial, which it had extracted from the trial publications. Adverse event data for both the lenalidomide and placebo arms of CALGB 100104 were available.</p>
<p>Why this issue is important</p>	<p>It is important for the committee to understand the risks associated with maintenance therapy with lenalidomide. Considering the absolute rates of adverse events in the lenalidomide arm of Myeloma XI alone may not accurately represent such risks. Additional between-arm comparison data for the population of interest would be advantageous.</p>
<p>Technical team preliminary judgement and rationale</p>	<p>The lack of adverse event data for the observation arm of the decision problem cohort of Myeloma XI is an important omission. If this data is not available, the technical team would</p>

	appreciate an attempt to obtain adverse event data for both lenalidomide and observation from alternative sources so that the risks of lenalidomide specifically in the population of interest can be better understood.
Questions for engagement	<ul style="list-style-type: none"> a) Is maintenance therapy with lenalidomide likely to have an acceptable safety profile? b) Are rates of serious adverse events in the intention-to-treat population of Myeloma XI likely to be generalisable to the decision problem cohort?

Issue 4 – Concerns with the company’s systematic review of economic evidence

<p>Background/description of issue</p>	<p>The company conducted a systematic literature review of economic evidence. Three separate search strategies were used for identifying existing economic evaluations, HRQoL evidence, and cost and resource use.</p> <p>The ERG raised several concerns with the company’s review of economic evidence (see section 4.1 of the ERG report). Its main concerns are:</p> <ul style="list-style-type: none"> • A lack of clarity in reporting • Discrepancies within review reports, for example in the PRISMA diagram for the HRQoL review • None of the studies identified in the cost and resource use review were used to inform the economic model. The company instead used Myeloma XI data, clinical advice, and previous technology appraisals. <p>Based on these issues, the ERG concluded that it lacked confidence in the review outputs and could not rule out selection bias for model inputs.</p>
<p>Why this issue is important</p>	<p>The systematic review is an important component of the economic evidence. It is important that the committee have confidence in the reporting and outputs of the review and in the approach taken to selecting model parameters.</p>
<p>Technical team preliminary judgement and rationale</p>	<p>Any discrepancies or omissions in the review of economic evidence should be rectified. There is currently a lack of transparency surrounding the choice of model inputs for cost and resource use due to the company not using the studies identified in the review. A full rationale for why alternative sources were chosen should be provided otherwise the presence of bias in the selection of model inputs cannot be ruled out.</p>
<p>Questions for engagement</p>	<p>a) Is it appropriate for the company to use alternative sources of costs and resource use rather than those identified by the systematic review?</p> <p>b) Is the company’s systematic review of economic evidence adequately reported?</p>

Issue 5 – The company’s method for estimating subsequent treatment costs may not be appropriate

Background/description of issue	<p>Both the company and the ERG agree that the therapies at or after 2nd line used in Myeloma XI no longer reflect UK clinical practice. Therefore, to estimate the costs of subsequent treatments, the company conducted a survey to elicit the frequencies of different types of subsequent treatments that would be used after first and second relapse from a sample of 8 UK multiple myeloma specialists. In its original submission, the company included treatments that were available via the cancer drugs fund (CDF), but it was asked to remove these at clarification. The company removed daratumumab with bortezomib and dexamethasone, and ixazomib with lenalidomide plus dexamethasone from the pathway and re-weighted the proportions of people receiving the remaining treatments (see response to clarification question B1).</p> <p>The ERG was concerned about the re-weighting approach because it does not represent treatments that would be used if those available only via the CDF were no longer available. Furthermore, the ERG argued that the company should have included the possibility of having another ASCT in the model because it is a relevant treatment option after first durable response. The ERG developed its own set of assumptions about subsequent treatments based on clinical expert advice (see section 4.2.8.4 of its report). The below table (from ERG report, Table 18) compares the company’s and ERG’s preferred assumptions for the proportions of people receiving different subsequent therapies following their first and second relapses. Additional ERG exploratory analysis demonstrates that subsequent therapy is a key driver of economic model results; when all subsequent therapy costs were removed (to establish the impact of cost savings relating to later treatment(s)), the company’s ICER increased to █████ per QALY (see ERG report section 6.2).</p>
--	---

	Comparison of company's and ERG's preferred subsequent therapies								
	Option	Company's base-case				ERG's base-case			
	Line	Post 1 st relapse		Post 2 nd relapse		Post 1 st relapse		Post 2 nd relapse	
Arm	Len	Obs	Len	Obs	Len	Obs	Len	Obs	
Len + dex		■		■		30.0%		70.0%	
Bor + dex	■	■	■	■	60.0%	40.0%	20.0%	10.0%	
Car + dex		■							
Pan + bor + dex			■	■				20.0%	5.0%
ASCT					15.0%	5.0%			
Pom			■						
Other	■	■	■	■	20.0%	20.0%	50.0%	5.0%	
No treatment	■	■	■	■	5.0%	5.0%	10.0%	10.0%	

ASCT, autologous stem cell transplant; bor, bortezomib; car, carfilzomib; dex, dexamethasone; ERG, Evidence Review Group; len, lenalidomide; obs, observation; pan, panobinostat; pom, pomalidomide. Note: For the purpose of informing the economic model, ASCT is considered in one line which may be under-costed when taking into account the costs of a reinduction regimen.

Why this issue is important	The cost of subsequent treatments is a key driver of cost effectiveness and has the greatest effect on the ICER of all the ERG's suggested changes to the base case (see Table 1: Impact of ERG's preferred assumptions on the cost-effectiveness estimate).
Technical team preliminary judgement and rationale	Both the company's and the ERG's estimates of proportions of people receiving subsequent lines of therapy have limitations and the model structure makes it difficult to vary assumptions. Both the company's and ERG's assumptions should be explored, along with the ERG's alternative sensitivity analyses to ensure uncertainty is fully captured.

Questions for engagement	<ul style="list-style-type: none">a) For people receiving lenalidomide maintenance therapy following ASCT, which therapies are they likely to receive at 2nd, 3rd and subsequent lines (not including therapies available through the cancer drugs fund [CDF])?b) For people receiving observation following ASCT, which therapies are they likely to receive at 2nd, 3rd and subsequent lines (not including therapies available through the cancer drugs fund [CDF])?c) Are people likely to receive a second ASCT? If so, at what point in the treatment pathway?d) Are the company's or the ERG's assumptions about subsequent treatments most appropriate?
---------------------------------	--

Issue 6 – The company provided highly uncertain estimates of overall survival, and the company and ERG disagree on which distribution to use for extrapolation

Background/description of issue	<p>When modelling survival data, models can be fit independently or jointly. If models are fitted independently, this means separate curves are fitted to each treatment arm. A joint model involves fitting a parametric curve to one arm and assumes a covariate for the other arm. The company used independent models to extrapolate OS because it found joint model estimates deviated from the Kaplan-Meier data for lenalidomide from Myeloma XI. It fitted independent models to the Myeloma XI OS data for lenalidomide maintenance and observation. It then used external CALGB 100104 trial data to select the most appropriate distribution because this trial had the longest follow up of the lenalidomide trials. It reported that it applied the rank preserving structural failure time (RPSFT) method to adjust for treatment switching in CALGB 100104 and used the resulting adjusted survival times to aid curve selection. However, no rationale for choosing RPSFT or supporting information on adjusting for treatment switching were provided. A log-logistic model was selected for the lenalidomide arm, and a Weibull model was selected for the observation arm. Based on the company's model, median OS was estimated to be ██████ in the lenalidomide arm and ██████ in the observation arm. By ██████, ██████ of patients had died in the observation arm, compared with ██████ of patients in the lenalidomide arm. See section B.3.2.5.2 of the company's submission.</p> <p>The ERG is concerned that the extrapolations are highly uncertain and may be overly optimistic (see sections 1.3, 4.2.6.1 and 6.4 of the ERG report). Its main concerns surrounding overall survival extrapolation are as follows:</p> <ul style="list-style-type: none">• Estimates of OS are based on relatively immature Myeloma XI trial data.• Survival in Myeloma XI is affected by subsequent treatments; however, the effects of individual subsequent therapies on survival are not explicitly captured within the company's economic model and there is a general lack of clarity surrounding which subsequent treatments were received in Myeloma XI. For example, it remains
--	--

	<p>unclear whether the company (in Table 65 of its appendices submission document) has provided information on treatments received by people in the full trial population or decision problem cohort. The company's partitioned survival analysis model structure prevents exploring alternative assumptions surrounding subsequent therapies (also see Table 2).</p> <ul style="list-style-type: none"> • The company's choice of assumptions imply [REDACTED]; the ERG does not consider this clinically plausible. The ERG also explored a potential waning of lenalidomide treatment effect starting at five years (see ERG report Figure 12); this led the company's base case ICER to increase to approximately [REDACTED] per QALY. • The company's use of the CALGB 100104 study to inform model selection should not have taken precedence over statistical or visual goodness-of-fit to the Myeloma XI data. <p>The ERG notes that that company did not provide statistical goodness-of-fit scores for the joint models. The ERG conducted its own analyses and preferred the use of a joint log-logistic model to inform its preferred base-case analysis. For the lenalidomide arm, projections were very similar to the company's base-case analysis (10-year OS was [REDACTED] or [REDACTED] based on the company's or ERG's estimates, respectively). For the observation arm, the ERG estimated 10-year OS as [REDACTED] compared with [REDACTED] in the company's base-case). See section 4.2.6.1 of the ERG report.</p> <p>The technical team notes UK statistics from the Office for National Statistics (ONS) indicate the predicted 10-year survival rate for multiple myeloma is 29%.</p>
<p>Why this issue is important</p>	<p>Overall survival extrapolation has an impact on the ICER because it affects how long people live in each arm of the model, and as a result, the accumulation of QALYs. It is important that the committee understand the full extent of uncertainty in survival estimates.</p> <p>If the ERG's joint log-logistic model is used instead of the company's independent models (log-logistic for the lenalidomide arm and Weibull for observation), the ICER increases (see ERG report Table 21).</p>

<p>Technical team preliminary judgement and rationale</p>	<p>The choice of extrapolation model should be predominantly based on goodness of fit to the Myeloma XI data rather than through external validation with the CALGB 100104 data because the CALGB 100104 trial has limited generalisability to UK clinical practice. Although if CALGB 100104 data are used, the methods used to adjust for treatment switching should be fully explained and justified.</p> <p>The ERG's prediction for 10-year survival in the observation arm is more closely aligned with UK estimates from the ONS.</p> <p>Different extrapolation scenarios, such as different distributions and treatment effect waning, should be explored. This is particularly important given the extent of uncertainty and the limitations associated with the model structure.</p>
<p>Questions for engagement</p>	<ul style="list-style-type: none"> a) Should a joint model or independent models be used to extrapolate OS? b) If independent models are chosen, is a log-logistic model appropriate for extrapolation of the lenalidomide maintenance arm and a Weibull model appropriate for extrapolation of the observation arm? c) How many patients are expected to be alive at 10 years in the lenalidomide arm? Is [REDACTED] a reasonable estimate? d) Is the company's ([REDACTED]) or the ERG's ([REDACTED]) estimate of the number of people alive after 10 years in the observation arm most appropriate? e) Is it appropriate to use CALGB 100104 data to inform OS curve model selection? If so, was the company correct to choose the rank preserving structural failure time (RPSFT) method to adjust for treatment switching in CALGB 100104, and why? f) Is there likely to be a waning of treatment effect with lenalidomide maintenance therapy? Or is the company's assumption of [REDACTED] more realistic?

Issue 7 – Uncertain impact of dose adjustments and wastage on drug costs

Background/description of issue	<p>The lenalidomide dose in the Myeloma XI trial was 10 mg per day on days 1 to 21 of a 28-day cycle. In its submission, the company adjusted the dose to account for RDI. It explained that this was to ensure consistency with the outcomes data from Myeloma XI, and confirmed that RDI was estimated as ■ based on the proportion of average dose / recommended dose of lenalidomide.</p> <p>In Section 4.2.8.1 of their report, the ERG note that it considers the impact of dose adjustments on drug costs to be uncertain because:</p> <ul style="list-style-type: none">• ■ of patients in Myeloma XI had a dose reduction (see Clarification response A11), but the proportions of patients that missed or had delayed doses is unclear. It is therefore unclear how the company's use of RDI accounts for wastage; this has cost-effectiveness implications because people are likely to be prescribed a pack every 28 days and incur the full price of a pack, regardless of whether they miss a dose.• the RDI estimate from Myeloma XI is ■, while the estimate from the TMM1 trial is 94.9%; the ERG highlight that the target dose was lower in Myeloma XI (10 mg per day) versus TMM1 (25 mg per day) so would be expected to be better tolerated and patients would be more likely to maintain the target dose.• Lenalidomide does not have a linear pricing structure; for example, a dose reduction from 10 mg to 5 mg is not associated with a 50% reduction in costs because of the different pack prices (21-tablet packs cost £3,780 for 10 mg or £3,570 for 5 mg). However, this is not accounted for in the company's model; it applies a flat discount to the price of a 10 mg pack based on the RDI in Myeloma XI. <p>Because of these uncertainties, in its base case the ERG used the lenalidomide RDI estimate from the TMM1 trial and also conducted a scenario analysis in which the RDI was set to 100% to establish the impact on cost-effectiveness results. Increasing the RDI lead to a substantial increase in the ICER (see ERG report Table 21).</p>
--	---

Why this issue is important	The different assumptions surrounding RDI can lead to ICER increases, and if wastage is not accounted for then the company's ICER may be optimistic.
Technical team preliminary judgement and rationale	Clinical advice is required on the likely RDI of lenalidomide in clinical practice. It is counterintuitive why the company's RDI estimate from Myeloma XI (■) at a lower dose is so much lower than the TMM1 trial. The lenalidomide costs should be adjusted to reflect the non-linear pricing structure.
Questions for engagement	<ul style="list-style-type: none"> a) In clinical practice, what is the likely relative dose intensity (RDI) of lenalidomide maintenance, i.e. the estimated percentage of doses actually delivered out of those that are planned? b) What are likely to be the main reasons to deviate from the recommended dosing of 10 mg per day on days 1 to 21 of a 28-day cycle (e.g. dose reduction, missed doses, etc.)? c) Should the RDI from the Myeloma XI trial (■) or TMM1 trial (95%) be used in the economic model? d) Are wastage costs appropriately accounted for?

Issue 8 – Whether medical resource use should differ between treatments and between relapse status

<p>Background/description of issue</p>	<p>The company made the following assumptions about medical resource use (see company submission B.3.4.2):</p> <ul style="list-style-type: none"> • Resource use and costs are the same between lenalidomide maintenance therapy and observation • Resource use and costs in the pre-progression state are higher than the post progression state <p>Resource use estimates were based on TA587 (Lenalidomide plus dexamethasone for previously untreated multiple myeloma) in the company’s base case. It also conducted a sensitivity analysis in which it used a chart review of 61 UK patients as a source.</p> <p>The ERG sought clinical advice on whether people would be managed differently depending on whether they were receiving lenalidomide maintenance or not, and whether their medical resource use would continue to differ following a relapse and further into the future. It heard that there are more monitoring costs with lenalidomide maintenance group because patients are receiving an active treatment. Therefore, in the ERG’s base case, management costs differ between treatment arms in the pre-progression (‘maintenance’) state with higher costs in the lenalidomide arm. A clinical expert supported this assumption by advising that lenalidomide will need more frequent monitoring (every 4 weeks) compared with observation (every 1–3 months).</p> <p>The ERG noted that the company assumed that resource use increases after relapse in TA587, whereas the review of 61 patient case notes showed a reduction in the per cycle costs post relapse. It therefore considers there to be a lack of clear evidence to support the company’s assumption that there is a difference in medical resource use between pre- and post-relapse states, so applied the same costs for both in its base case (see ERG report 4.2.8.2).</p> <p>The company’s and ERG’s cost assumptions are summarised in the table below.</p>
---	--

	Medical resource use costs per 28-day cycle				
		Company		ERG	
		Pre-progression	Post-progression	Pre-progression	Post-progression
	Lenalidomide	£255	£231	£255	£173
Observation	£255	£231	£173	£173	

Why this issue is important	If lenalidomide were associated with greater resource use and costs compared with observation, then the company's base case ICER may be optimistic. In the ERG's base case, halving the pre-relapse outpatient visits for observation results in an increase to the ICER (see Table 1: Impact of ERG's preferred assumptions on the cost-effectiveness estimate). Assuming the same resource use between pre- and post-relapse makes very little difference to the company's ICER.
Technical team preliminary judgement and rationale	Lenalidomide maintenance therapy is likely to be associated with greater medical resource use compared with observation. It is unclear whether medical resource use costs are likely to differ between the pre- and post-progression states.
Questions for engagement	<ul style="list-style-type: none"> a) Is medical resource use likely to be the same between maintenance therapy with lenalidomide and observation? If not, how do they vary? b) Is medical resource use likely to be the same in the pre-progression and post-progression states? If not, how do they vary? c) Are the company's or ERG's estimates of medical resource use costs the most appropriate?

4. Issues for information

Tables 1 to 3 are provided to stakeholders for information only and not included in the technical report comments table provided.

Table 1: Impact of ERG's preferred assumptions on the cost-effectiveness estimate

Alteration	Discussion of issue	Apply assumptions individually		Apply assumptions cumulatively	
		ICER (£/QALY)	ICER change (£/QALY)	ICER (£/QALY)	ICER incremental change (£/QALY)
Company base case ^a	–	██████		██████	
Set OS curve to joint log-logistic	Issue 6	██████	██████	██████	██████
Set PFS curve to joint Weibull	Table 3	██████	██████	██████	██████
Set RDI for lenalidomide maintenance to 94.9%	Issue 7	██████	██████	██████	██████
Set medical resource use costs post-relapse same as pre-relapse	Issue 8	██████	██████	██████	██████
Halve pre-relapse outpatient visits for observation	Issue 8	██████	██████	██████	██████
ERG's preferred subsequent treatment settings	Issue 5	██████	██████	██████	██████
Set cost of 'other' subsequent therapy regimen to cost of CTD regimen	Table 3	██████	██████	██████	██████
Cost of bortezomib from eMIT	Table 3	██████	██████	██████	██████
ERG base case ^a	–	–	–	██████	██████

^a Includes PAS discounts for lenalidomide and pomalidomide. Company base case uses an assumed PAS discount for bortezomib, while ERG base case uses bortezomib price from eMIT. List prices used for all other treatments; CTD, cyclophosphamide, thalidomide, and dexamethasone; eMIT, Drugs and pharmaceutical electronic market information tool; OS, overall survival; PAS, patient access scheme; PFS, progression-free survival; RDI, relative dose intensity.

Technical report – Lenalidomide for the maintenance treatment of multiple myeloma after autologous stem cell transplant Page 31 of 36

Issue date: June 2020

© NICE 2020. All rights reserved. Subject to [Notice of rights](#).

Table 2: Outstanding uncertainties in the evidence base

Area of uncertainty	Why this issue is important	Likely impact on the cost-effectiveness estimate
<p>The company's partitioned survival analysis model structure may be overly simple because it prevents alternative assumptions surrounding subsequent therapies being fully explored</p>	<p>It is important to capture the costs and effects of therapies following progression because they affect cost-effectiveness results.</p> <p>The ERG is concerned that the structure of the partitioned survival analysis model does not allow it to estimate the cost-effectiveness of lenalidomide maintenance therapy because the costs and effects of treatments given 2nd line and beyond are highly uncertain, yet drive model results. The partitioned survival analysis model structure prevents exploring alternative assumptions surrounding subsequent therapies, so does not capture the uncertainty in the cost-effectiveness estimates (see section 4.2.2 of the ERG report for a full discussion on the model structure).</p> <p>The company acknowledges its model structure has limitations and that it could have considered a multi-state model; it noted that there are limited data to estimate health state transitions (see clarification response to question B7).</p>	<p>Structural limitations to the model mean there is likely to be substantial uncertainty in the ICER.</p>
<p>Clinical evidence in the company submission is from an unplanned analysis of a subpopulation from the wider Myeloma XI trial</p>	<p>The analysis of data from the Myeloma XI subpopulation relevant to the decision problem (see Topic Background, section 1.9) was unplanned and results are not published elsewhere (see company response to clarification question A16). In its report, the ERG highlighted a number of limitations with using this data, although it acknowledges that randomisation is retained for the cohort and there is</p>	<p>No substantial impact on cost-effectiveness estimate.</p>

Area of uncertainty	Why this issue is important	Likely impact on the cost-effectiveness estimate
	<p>unlikely to be substantial bias introduced by the lack of pre-planning (see ERG report sections 3.2.1, 3.2.5 and 3.6).</p> <p>The technical team considers that although using evidence from an unplanned subgroup has limitations, the company's choice to use data from the subgroup of Myeloma XI relevant to the decision problem is appropriate and is unlikely to substantially affect cost-effectiveness results.</p>	
<p>Induction treatments used in the Myeloma XI trial may no longer reflect current NHS practice</p>	<p>If the type of induction therapy alters the subsequent lenalidomide treatment effect, then any issues with the generalisability of induction treatments used in Myeloma XI to NHS practice could make the results of the study less generalisable.</p> <p>However, clinical advice to the ERG suggests that the effect of lenalidomide would not vary according to the induction therapy received and therefore the Myeloma XI data remain relevant to UK clinical practice (see ERG report section 3.2.1.4). Based on this, the technical team considers that the choice of induction regimen is unlikely to substantially affect cost-effectiveness results.</p>	<p>No substantial impact on cost-effectiveness estimate.</p>

Table 3: Other issues for information

Issue	Comments
<p>Other ERG changes to base case</p>	<p>The ERG made several other changes to the company’s base case, all of which have a minimal effect on the ICER:</p> <ul style="list-style-type: none"> • Set cost of the ‘other’ therapies used 2nd line and beyond as equivalent to the cost of the cyclophosphamide, thalidomide, and dexamethasone regimen (based on clinical advice) • [REDACTED] from bortezomib and use the price available from the ‘Drugs and pharmaceutical electronic market information tool’ (eMIT)
<p>Age-related effects on utility may be over-estimated</p>	<p>The ERG highlights that the patient population in the study by Acaster et al. (2013), which was used as source of utility values for multiple myeloma, are slightly older on average than the Myeloma XI population. This could lead to an over-estimation of the age-related effects on utility and affect the ICER. The company’s base case ICER decreases slightly, from [REDACTED] per QALY to [REDACTED] per QALY when the ERG delayed age adjustment on utility by five years to correct for this issue.</p>
<p>Concerns with the PSA</p>	<p>The ERG identified discrepancies between the company’s economic model and reporting in the company submission in terms of distributions used for the PSA. It also had several other concerns with the approach taken to perform PSA (see ERG report section 5.2.2). The PSA results differed when the ERG used the parameters reported in the company’s submission rather than the economic model.</p>
<p>Choice of distribution for progression-free survival extrapolation</p>	<p>The company and the ERG agree that joint models fit the data for PFS from Myeloma XI and an independent modelling approach is not required. The company concluded that log-logistic and exponential distributions are the most plausible extrapolations when considering fit to the curves for PFS from CALGB 100104, however the log-logistic provides optimistic estimates for PFS so it chose an exponential distribution for its base case (see section B.3.2.5.1 of the company submission). The ERG preferred the Weibull model based on statistical and visual</p>

Issue	Comments
	goodness-of-fit and because it does not result in substantially dissimilar PFS estimates compared with other models (see section 4.2.6.2 of ERG report). The choice of distribution has very little effect on the ICER (see Table 1).
Health state utility values	<p>The ERG agrees with the company's decision to use utility values from a study by Acaster et al. (2013). The utility values are 0.72 for the pre-progression state and 0.67 for the progressed state.</p> <p>The ERG also agrees with the company's approach to applying utility decrements related to adverse events.</p>
Medical resource use and adverse event costs	<p>The ERG considers the unit costs used to inform medical resource use in the company's model appropriate.</p> <p>Although the ERG had some very minor concerns about the costs used for anaemia and sepsis, overall, it agrees with the company's approach to costing adverse events.</p>
Equality considerations	No equalities issues were identified by the company, consultees and their nominated clinical experts and patient experts.

Authors

Amanda Adler

Appraisal committee chair

Hannah Nicholas

Technical lead

Eleanor Donegan

Technical adviser

Nicole Elliott

Associate director

With input from the lead team:

Mark Glover

Lead team member

Rhiannon Owen

Lead team member

Tony Wootton

Lead team member

Technical engagement response form

Lenalidomide for the maintenance treatment of multiple myeloma after autologous stem cell transplant [ID475]

As a stakeholder you have been invited to comment on the technical report for this appraisal. The technical report and stakeholders responses are used by the appraisal committee to help it make decisions at the appraisal committee meeting. Usually, only unresolved or uncertain key issues will be discussed at the meeting.

We need your comments and feedback on the questions below. You do not have to answer every question. The text boxes will expand as you type. Please read the notes about completing this form. We cannot accept forms that are not filled in correctly. Your comments will be summarised and used by the technical team to amend or update the scientific judgement and rationale in the technical report.

Deadline for comments: **17th July 2020**

Thank you for your time.

Please log in to your NICE Docs account to upload your completed form, as a Word document (not a PDF).

Notes on completing this form

- Please see the technical report which summarises the background and submitted evidence. This will provide context and describe the questions below in greater detail.
- Please do not embed documents (such as PDFs or tables) because this may lead to the information being mislaid or make the response unreadable. Please type information directly into the form.
- Do not include medical information about yourself or another person that could identify you or the other person.
- Do not use abbreviations.
- Do not include attachments such as journal articles, letters or leaflets. For copyright reasons, we will have to return forms that have attachments without reading them. You can resubmit your form without attachments, but it must be sent by the deadline.
- If you provide journal articles to support your comments, you must have copyright clearance for these articles.
- Combine all comments from your organisation (if applicable) into 1 response. We cannot accept more than 1 set of comments from each organisation.

- Please underline all confidential information, and separately highlight information that is submitted under **'commercial in confidence'** in turquoise, all information submitted under **'academic in confidence'** in yellow, and all information submitted under **'depersonalised data'** in pink. If confidential information is submitted, please also send a second version of your comments with that information replaced with the following text: 'academic/commercial in confidence information removed'. See the [Guide to the processes of technology appraisal](#) (sections 3.1.23 to 3.1.29) for more information.

We reserve the right to summarise and edit comments received during engagement, or not to publish them at all, if we consider the comments are too long, or publication would be unlawful or otherwise inappropriate.

Comments received during engagement are published in the interests of openness and transparency, and to promote understanding of how recommendations are developed. The comments are published as a record of the comments we received, and are not endorsed by NICE, its officers or advisory committees.

About you

Your name	Emanuela Castelnovo
Organisation name – stakeholder or respondent (if you are responding as an individual rather than a registered stakeholder please leave blank)	Celgene Ltd
Disclosure Please disclose any past or current, direct or indirect links to, or funding from, the tobacco industry.	None

Questions for engagement

Issue 1: The lenalidomide regimen in the company submission is not aligned with the marketing authorisation	
<p>a) What dosing schedule would be used in clinical practice for maintenance therapy with lenalidomide following ASCT: 1 to 21 days or 1 to 28 days of a 28-day cycle?</p>	<p>Based on clinical expert advice there is strong consensus the D1-21 / 28-day dosage schedule is what will be used in clinical practice when lenalidomide maintenance therapy is reimbursed.</p> <p>Clinicians have experience and familiarity with using the 21 out of 28-day schedule for lenalidomide in transplant non-eligible patients in NHS practice (being the standard schedule in that setting), and will need to maintain tolerability by giving patients a break from treatment for 1 week in every 4 weeks.</p> <p>It should be emphasised that the aim of maintenance therapy is to suppress recurrence of disease / maintain disease quiescence, rather than to treat it <i>per se</i>. With this in mind, duration of treatment rather than the actual dose is more important in the maintenance setting. Hence, it is important to keep patients on treatment by using a dosage that they can tolerate for as long as possible.</p>
<p>b) Is lenalidomide likely to be as effective and safe over 1 to 21 days as it is over 1 to 28 days of a 28-day cycle?</p>	<p>The therapeutic intent for maintenance is to sustain remission achieved with the ASCT. Lenalidomide is started at 10mg, with the possibility to decrease the dose to 5mg to improve tolerance and maximise the duration of maintenance therapy.</p> <p>There is no evidence to support that the 21-day schedule would be less effective than the 28-day schedule. For reasons explained above, it is more likely to be better tolerated since it allows patients a 1-week break from treatment in every 4 weeks.</p> <p>In the CALGB study (28/28-day schedule), the PFS benefit for lenalidomide maintenance therapy compared to placebo/observation only is similar to that of the Myeloma XI decision</p>

	<p>problem cohort (21/28-day schedule) (median PFS: [REDACTED] [REDACTED] CALGB 100104 - 57.3 vs. 28.9 months; HR 0.57 [0.46-0.71]).</p> <p>Whilst the median [REDACTED] [REDACTED] which concurs with the most recent reported data from the CALGB study (Holstein et al. 2017).</p>
<p>c) If a 1 to 28-day dosing schedule is used a) are the results of the Myeloma XI trial generalisable to clinical practice in the NHS, and b) are there any implications for drug wastage?</p>	<p>For reasons explained in our response to question a), it is most likely that the D1-21/28 dosage schedule will be adopted for lenalidomide maintenance therapy in clinical practice.</p> <p>The Myeloma XI is the largest trial in multiple myeloma conducted so far, informed by real clinical practice, and includes patients recruited from 110 treatment centres all located in the UK. Nevertheless, it would be misleading to use the Myeloma XI data to assess the impact of a 28/28-day regimen because this dosage was not studied in Myeloma XI.</p> <p>With regards to drug wastage, the Myeloma XI data provide robust evidence of the range of therapeutic dosing for maintenance with lenalidomide, accounting for dose reductions to 5mg, dose alternations (10mg alternated with 5mg), treatment breaks between cycles and treatment interruptions during cycles, providing a real world representation of dose adjustments and changes. A new analysis of Myeloma XI dosages is presented in the Addendum attached to this response, including results for the frequency of dose reduction, an overview of treatment patterns and treatment free intervals and an assessment of the most likely wastage given the prescribed dosages from Myeloma XI. For the results of this analysis please see the Addendum.</p>
<p>d) What proportion of patients are likely to escalate their dose to 15 mg once daily in clinical practice?</p>	<p>In Myeloma XI, an increase to 15mg was not allowed. Advice from clinical experts is that patients are extremely unlikely to have their dose of lenalidomide escalated from 10mg to 15mg in clinical practice.</p> <p>The aim of maintenance therapy is to prolong disease remission and prevent relapse rather than to treat the disease <i>per se</i>, and therefore it is preferable to keep patients on a dose they can</p>

tolerate. Clinical experts advise that there is no evidence that escalating the dose of lenalidomide would be of clinical benefit in the maintenance setting.

Issue 2: The company excluded evidence from potentially relevant clinical trials

a) Are the CALGB 100104 and GIMEMA trials, which both use the dosing schedule in the marketing authorisation, relevant to the decision problem and should the results be considered by the committee?

GIMEMA

For a number of reasons outlined below, the GIMEMA study (Palumbo et al. 2014) does not provide data from a population that matches the decision problem: patients who received lenalidomide maintenance therapy post ASCT.

The GIMEMA study was a 2x2 factorial randomised trial, in which participants were assigned to one of 4 groups based on random allocation to stage 1 intervention (HDM + ASCT vs MPR) followed by another random allocation to a second-stage intervention (lenalidomide maintenance vs no maintenance).

The comparison of maintenance vs no maintenance in people who received MPR is clearly not relevant, as it does not fulfil the license for maintenance with lenalidomide neither it matches the decision problem.

In addition, the comparison between ASCT + maintenance and ASCT + no maintenance is also invalid in the context of this submission. This is because:

1. Patients were randomised **at study recruitment** to one of four treatment sequences, HDM + ASCT or MPR, followed by maintenance or no therapy
2. Patients would then proceed to stage 1 treatment, initiation to induction and if responders, proceed to ASCT). Importantly, those that failed induction became ineligible for ASCT and consequently, also became ineligible for maintenance;
3. the second randomisation (maintenance vs no maintenance) would be **disclosed** when patients reached the time to start maintenance or not; patient were therefore re-assessed for eligibility for maintenance or not, i.e.

- a. patients randomised to ASCT +/- maintenance that had failed induction by-passed HDM + ASCT and became therefore ineligible for maintenance (as per indication);
- b. patients who proceeded to HDM + ASCT but failed engraftment (a rare occurrence) also became ineligible for maintenance (this would be the normal criterion).

Both groups were retained in the study as part of the ITT, and likely surviving past the time when maintenance therapy would start, as stated in the publication by Palumbo et al (2014), p.897: *“patients in whom progressive disease developed during induction or consolidation therapy were treated according to local standards and remained in the trial for later outcome evaluations”*.

In Myeloma XI, also a multifactorial RCT, participants underwent subsequent randomisations after eligibility for the next treatment (maintenance was one of them) was confirmed and ineligible participants were excluded from randomisation. This is the reason why in Myeloma XI the maintenance group includes no participants who did not receive maintenance, whilst GIMEMA does. For these reasons, GIMEMA suffers from dilution biases generated by the study design, and specifically invalidating the comparison between maintenance vs no maintenance for the purposes of this Appraisal.

Another important issue in GIMEMA was that all patients in the study had received lenalidomide prior to the stage 2 allocation to lenalidomide maintenance or no maintenance (all patients received 4 cycles of induction with lenalidomide, and 1 group also received 6 cycles of MPR). In summary, no participants in GIMEMA remained unexposed to lenalidomide prior to receiving maintenance therapy.

For these reasons GIMEMA is not a suitable study to inform this appraisal.

The CALGB study was used as an external validation study for Myeloma XI extrapolations in the original submission. During Technical Engagement, we added an analysis based on the pooled CALGB and Myeloma XI data, formally including the CALGB data into the model, and replacing the use of CALGB as external validation study. The additional analyses are reported in the Addendum.

<p>b) Is it appropriate to synthesise data from Myeloma XI, CALGB 100104 and GIMEMA (for example, in a network meta-analysis)?</p>	<p>For the reasons explained above, GIMEMA cannot be considered part of the evidence base. A newly generated pooled analysis of CALGB and Myeloma XI is provided in the Addendum.</p>
<p>c) Should CALGB 100104 and GIMEMA trial data be used in the economic model?</p>	<p>GIMEMA should not be considered as part of the evidence base.</p> <p>CALGB data are incorporated in the model as validation data (original submission) and the new pooled analysis</p> <p>██</p> <p>compared with CALGB (median 25.4 months, 95% CI 19.9 - 30.8, n = 224, 16.1% on treatment at last follow-up) yet the PFS findings were very similar between the two studies. Reasons for this difference in treatment duration are potentially due to the rates of grade 3/4 haematological toxicities in the lenalidomide arm of the CALGB 100104 study (Table 1, Appendix; adapted from Holstein et al. 2017). As can be seen in Table 2, Appendix, cytopenias/ neutropenia/thrombocytopenia were the most common reason for discontinuing lenalidomide. CALGB used the continuous lenalidomide dosing schedule of days 1 to 28 of a 28-day cycle. As discussed in questions 1a) and 1b), a 21 out of 28-day schedule as used in Myeloma XI may be more tolerable for patients and more likely to keep them on treatment by giving them a break from therapy for 1 week out of every 4 weeks.</p>
<p>Issue 3: The company did not present adverse event data for the observation arm of the target population from Myeloma XI</p>	
<p>a) Is maintenance therapy with lenalidomide likely to have an acceptable safety profile?</p>	<p>Clinical experts have confirmed that lenalidomide as maintenance therapy is highly likely to have an acceptable safety profile.</p> <p>The reason that no adverse event (AE) data were provided in the company submission for the observation arm in the Myeloma XI decision problem cohort is that AE data was not collected for patients in the observation arm in Myeloma XI because they were not receiving lenalidomide or any other active treatment.</p> <p>Lenalidomide has been licensed for use in the management of patients with multiple myeloma (MM) for nearly 15 years and the estimated cumulative exposure during trials and post-approval</p>

experience is approximately [REDACTED]. The safety profile of lenalidomide is therefore very well characterised and the AEs are well known and understood.

AE data for lenalidomide maintenance compared to observation/placebo are available from the CALGB 100104 study (Holstein et al. 2017, Table 1, Appendix of this document.). Data for the observation/placebo arm are categorised by whether or not patients crossed over from placebo to receive lenalidomide; the non-crossover group providing a more appropriate characterisation of events associated with observation only.

More grade 3 or 4 haematologic adverse events occurred in patients in the lenalidomide group than in the placebo non-crossover group; in particular, more patients in the lenalidomide group had grade 3 or 4 neutropenia.

There were more grade 3 or 4 non-haematologic adverse events (e.g. rash, diarrhoea) in the lenalidomide group than in the placebo non-crossover group; however, this is primarily due to more grade 3 events in the lenalidomide arm and there were no significant differences between the groups with respect to numbers of grade 4 events.

Second primary malignancies (SPMs) that were diagnosed after randomisation to maintenance therapy but before progression are tabulated in Table 3 (Appendix); again data for the placebo arm are separated by crossover and no crossover. 18 (8%) haematological, 14 (6%) solid tumour, and 11 (5%) non-invasive second primary malignancies were diagnosed in the lenalidomide group, compared with none haematological, four (3%) solid tumour, and one (<1%) non-invasive SPMs in the placebo non-crossover group.

Clinical experts have advised that these data provide a reasonable estimate of the likely adverse events that can be expected with lenalidomide maintenance therapy in clinical practice, albeit the toxicities in the lenalidomide arm of the CALGB 100104 study may be slightly over-estimated due to use of the D1-28/28 day dosage schedule compared with a D1-21/28 day schedule, particularly with regards to the haematological toxicities and fatigue. HCPs are familiar with and experienced in managing the common AEs associated with lenalidomide treatment using the

	<p>algorithms available in the Revlimid® Summary of Product Characteristics (SmPC) and in their own institutions.</p> <p>Clinical experts have indicated that the main safety concern associated with the use of lenalidomide maintenance therapy would be the development of SPMs. As advised in the Revlimid® SmPC, physicians will need to monitor their patients during treatment using standard cancer screening protocols and institute treatment if needed. Nevertheless, it is recognised that the benefits of receiving lenalidomide maintenance therapy compared with observation only in terms of an extension to progression-free and overall survival outweigh the risk of SPMs (Jones et al. 2016).</p>
<p>b) Are rates of serious adverse events in the intention-to-treat population of Myeloma XI likely to be generalisable to the decision problem cohort?</p>	<p>Large differences in serious adverse events (SAEs) between the ITT population and the decision problem cohort would be expected.</p> <p>Clinical experts have advised that, if anything, potential SAEs associated with lenalidomide maintenance therapy post ASCT are likely to be over-estimated in the ITT population through the inclusion of patients who were not eligible for an ASCT. Patients who were not eligible for an ASCT would have been older and frailer and therefore potentially more likely to experience adverse events. Additionally, patients who received lenalidomide at the 25mg dose were included in the ITT population. Furthermore, clinical advice indicates that it would be highly unlikely that there would have been any carry over effects from induction therapy in the ASCT-eligible participants because maintenance therapy was started ~100 days after ASCT.</p>
<p>Issue 4: Concerns with the company’s systematic review of economic evidence</p>	
<p>a) Is it appropriate for the company to use alternative sources of costs and resource use rather than those identified by the systematic review?</p>	<p>We believe resource utilisation in our model is appropriate, given the lack of alternatives that were identified in the literature. The costs and resources used in models identified from the systematic review pertain to the Spanish and Australian jurisdictions (Appendix, Document B). Resource use information is also largely not pertinent to the UK (Addendum, Section 7). Therefore, they would reflect health care delivery arrangements in systems that are not representative for the UK. The original submission included a comparison of the results of models identified in the literature with the model for our submission and remains a reasonable representation of the differences between these models and the ours.</p>

<p>b) Is the company's systematic review of economic evidence adequately reported?</p>	<p>We have replicated the systematic review of literature reporting resource use and costs, as well as utility values for maintenance with lenalidomide. The screening and identification of included studies have been reported in the Addendum, Sections 6 and 7.</p>
--	---

Issue 5: The company's method for estimating subsequent treatment costs may not be appropriate

<p>a) For people receiving lenalidomide maintenance therapy following ASCT, which therapies are they likely to receive at 2nd, 3rd and subsequent lines (not including therapies available through the cancer drugs fund [CDF])?</p>	<p>With the exclusion of therapies available through the CDF, clinical experts have advised that bortezomib in combination with dexamethasone (bort + dex) would be the most widely used second-line therapy (at first relapse) with an equal distribution between patients receiving lenalidomide and those on observation.</p> <p>Clinical advice indicates that a second ASCT would rarely be undertaken in patients at first relapse on lenalidomide maintenance therapy (though if done, this would be in the same proportions of patients in both the lenalidomide and observation arms). Please see response to question 5c) for a more detailed rationale and discussion on this point.</p> <p>The remaining patients would receive either 'other treatment' such as a chemotherapy-based combination or no treatment at first relapse on lenalidomide maintenance therapy.</p> <p>At second relapse (third-line), the majority of patients who received lenalidomide maintenance would receive either bort + dex or the combination of panobinostat plus bortezomib and dexamethasone (pano + bort + dex), with the remaining patients getting other treatments or no treatment.</p> <p>The company's revised assumptions for subsequent therapies for patients receiving lenalidomide maintenance therapy following ASCT are tabulated below:</p> <p>Likely subsequent therapies in patients receiving lenalidomide maintenance therapy post ASCT</p> <table border="1" data-bbox="772 1220 1534 1388"> <thead> <tr> <th data-bbox="772 1220 1064 1276">Option</th> <th colspan="2" data-bbox="1064 1220 1534 1276">Lenalidomide</th> </tr> </thead> <tbody> <tr> <td data-bbox="772 1276 1064 1388"></td> <td data-bbox="1064 1276 1288 1388">Post 1st relapse (2nd line)</td> <td data-bbox="1288 1276 1534 1388">Post 2nd relapse (3rd line)</td> </tr> </tbody> </table>	Option	Lenalidomide			Post 1 st relapse (2 nd line)	Post 2 nd relapse (3 rd line)
Option	Lenalidomide						
	Post 1 st relapse (2 nd line)	Post 2 nd relapse (3 rd line)					

	<table border="1"> <tr><td>Len + dex</td><td></td><td></td><td></td><td></td><td></td></tr> <tr><td>Bort + dex</td><td></td><td></td><td></td><td></td><td></td></tr> <tr><td>Car + dex</td><td></td><td></td><td></td><td></td><td></td></tr> <tr><td>Pano + bort + dex</td><td></td><td></td><td></td><td></td><td></td></tr> <tr><td>ASCT</td><td></td><td></td><td></td><td></td><td></td></tr> <tr><td>Pom</td><td></td><td></td><td></td><td></td><td></td></tr> <tr><td>Other</td><td></td><td></td><td></td><td></td><td></td></tr> <tr><td>No treatment</td><td></td><td></td><td></td><td></td><td></td></tr> </table>	Len + dex						Bort + dex						Car + dex						Pano + bort + dex						ASCT						Pom						Other						No treatment						
Len + dex																																																		
Bort + dex																																																		
Car + dex																																																		
Pano + bort + dex																																																		
ASCT																																																		
Pom																																																		
Other																																																		
No treatment																																																		
<p>b) For people receiving observation following ASCT, which therapies are they likely to receive at 2nd, 3rd and subsequent lines (not including therapies available through the cancer drugs fund [CDF])?</p>	<p>With the exclusion of therapies available through the CDF, clinical experts have advised that bort + dex would be the most widely used second-line therapy with an equal distribution between patients receiving lenalidomide and observation.</p> <p>It is unlikely that lenalidomide plus dexamethasone (len + dex) would be a frequent option at first relapse for patients receiving observation following an ASCT because it is not within NICE’s reimbursement recommendations. Lenalidomide in second-line is only reimbursed for patients who are not eligible for an ASCT [TA586]. The guidance states in section 3.1: “The committee understood that the population relevant to this appraisal includes people for whom neither a stem cell transplant [...] is suitable”; and “It agreed that the relevant population includes people who cannot have a stem cell transplant”. Lenalidomide is reimbursed in ASCT-eligible people only from third and subsequent lines [TA171] and this is reflected in the company’s revised assumptions below.</p> <p>Pano + bort + dex would be an alternative option at first relapse in a small proportion of patients. As mentioned in 5a) above and discussed further in 5c), ASCT would only be rarely undertaken at first relapse (with no difference in distribution between patients receiving observation or lenalidomide maintenance). The remaining patients would be expected to receive other treatments or no treatment.</p>																																																	

Carfilzomib plus dexamethasone (car + dex) is a treatment option limited to a very small number of patients given its restriction to patients who have not received bortezomib (TA457) and the fact that those who receive lenalidomide maintenance following an ASCT are likely to have received a bortezomib-based induction regimen.

The company's revised assumptions for subsequent therapies for patients receiving observation following ASCT are tabulated below:

Likely subsequent therapies in patients receiving observation post ASCT

Option	Observation	
	Post 1 st relapse (2 nd line)	Post 2 nd relapse (3 rd line)
Len + dex		
Bort + dex		
Pano + bort + dex		
Car + dex		
ASCT		
Pom		
Other		
No treatment		

c) Are people likely to receive a second ASCT? If so, at what point in the treatment pathway?

Whilst a second ASCT following relapse on lenalidomide maintenance therapy is a potential treatment option, advice from clinical experts indicates that it would be a rare and decreasing option in NHS practice.

Importantly, a second ASCT is not an appropriate treatment option for a progressing patient and it would be necessary to get a patient back into remission through re-induction, before undertaking a second ASCT. In other words, it does not technically qualify as a second-line therapy for a patient that has relapsed/ is relapsing on maintenance therapy and it is not strictly

	<p>funded unless a patient has successfully completed re-induction therapy without disease progression (NG35).</p> <p>Additionally, there would be no clinical explanation as to why there would be differential rates of second ASCT between the lenalidomide and observation arms; indeed, there are no clinically plausible reasons why a patient who has received lenalidomide maintenance therapy would be more likely to receive a second ASCT than a patient on observation only.</p> <p>Low rates of second ASCT following maintenance therapy are reflected in the Myeloma XI trial in which very few patients went onto to receive a second ASCT upon progression in the maintenance phase of the study (██████████ in the lenalidomide arm and ██████████ in the observation, See Table 65 in Appendix P (p.138) of Document B).</p> <p>Furthermore, in the company’s physician survey of subsequent therapies after maintenance treatment, whilst HCPs could have noted ASCT in the ‘other’ therapies section, no physicians responded that ASCT would be an option they would consider for subsequent therapy.</p> <p>Given that lenalidomide maintenance significantly prolong remissions compared to observation only, there is also the question of whether patients would remain suitable for an ASCT several years down the line (it is possible they could be too old, no longer be fit enough and/or suffering with co-morbidities).</p> <p>For these reasons, we strongly believe that the ERG’s assumption that 15% of patients would receive a second ASCT at first relapse after lenalidomide maintenance is unrealistic and too high. The ERG’s differential assumptions of 15% of patients for the lenalidomide arm and 5% for observation is not supported by clinical experts. Indeed, this contradicts the ERG’s own clinical advice (section 4.2.8.4 of the ERG report) that patients would be expected to receive any subsequent treatment across both arms in similar proportions (with an exception pertaining to the re-use of lenalidomide). Any assumption regarding a second ASCT should therefore be very low and applied equally to the lenalidomide and observation arms.</p>
<p>d) Are the company’s or the ERG’s assumptions about subsequent treatments most appropriate?</p>	<p>As a general point, clinical experts have advised that the exclusion of CDF therapies creates an artificial situation that does not reflect current clinical practice with respect to subsequent therapies.</p>

	<p>Clinical experts have indicated that in real-world clinical practice the combination of daratumumab + bortezomib + dexamethasone would dominate followed by bort + dex at first relapse (second-line) with equal distributions in both treatment groups. At second relapse (third-line), pano + bort + dex would be the most common subsequent therapy for patients receiving lenalidomide maintenance and ixazomib + lenalidomide + dexamethasone for patients receiving observation.</p> <p>Clinical advice concurs with that of the ERG's (section 4.2.8.4 of the ERG report) that whether or not a patient has received lenalidomide maintenance therapy would not have a substantial influence on subsequent therapies (except that patients who have previously received lenalidomide would not generally receive another lenalidomide-containing regimen, and/or where restrictions placed by NICE guidance apply).</p> <p>Drawing on the rationale above, we included our most recent assumptions, excluding therapies available via the CDF and drawing on a combination of our own and the ERG's assumptions, in the Tables in response to questions 5a) and 5b) above.</p>
<p>Issue 6: The company provided highly uncertain estimates of overall survival, and the company and ERG disagree on which distribution to use for extrapolation</p>	
<p>a) Should a joint model or independent models be used to extrapolate OS?</p>	<p>We used joint models to estimate extrapolations for lenalidomide and observation in the new updated base case.</p>
<p>b) If independent models are chosen, is a log-logistic model appropriate for extrapolation of the lenalidomide maintenance arm and a Weibull model appropriate for extrapolation of the observation arm?</p>	<p>The updated base case uses the same set of distributions as in the old base case, however since we formally incorporated the CALGB data in the analysis, the best fitting curves are not the same distributions as in the previous base case. We defer to the Addendum for a discussion of new distributions chosen for the base case and rationale.</p>
<p>c) How many patients are expected to be alive at 10 years in the lenalidomide arm? Is [REDACTED] a reasonable estimate?</p>	<p>We used the model to assess the proportion of people alive at 10 years in both arms. With lenalidomide maintenance, the proportion of people alive at 10 years [REDACTED] with observation.</p>

d) Is the company's (████████) or the ERG's (████████) estimate of the number of people alive after 10 years in the observation arm most appropriate?

We believe the ONS estimates are biased due to the reasons explained below and therefore, for the purposes of this Appraisal, they provide misleading proportions of survival at 5 and 10 years. We trust that the analysis of individual level patient data from two large studies (Myeloma XI and CALGB) that are unbiased with respect to the target population for this Appraisal

The Office for National Statistics (ONS) 29% estimate for predicted 10-year survival for people with MM is not a reliable estimate to inform the 10-year survival of patients receiving observation following ASCT. This estimate is based on all MM diagnoses between 2013-2017, modelled for 'people diagnosed in 2018', and is therefore based on short follow-up (between 1 and 4 years of follow-up post-ASCT, with a likely mean follow up of about 2 years, assuming ~12 months for induction and ASCT).

In addition, this estimate reflects the totality of the UK MM population which would include both transplant eligible and transplant non-eligible patients and does not take account of treatments patients have received, are receiving now or will subsequently receive.

Perhaps more importantly, the ONS estimates, far from representing a 'maintenance free' population for the UK, they are highly likely to be confounded by the inclusion of people who received maintenance in the Myeloma XI study in that period.

Myeloma XI was a very large, real world UK clinical trial involving more than 4,400 people (n=4,420) and was conducted in approximately the same period as the ONS data (2011-2017). The inclusion of these patients in the ONS statistics may have in itself impacted the ONS estimate.

In Myeloma XI, ██████████ participants were randomised to maintenance (both transplant-eligible and non eligible) and ██████████ to lenalidomide + vorinostat (years ██████████): of all, ██████████ were randomised in the years between 2013-2016. (Also see D1.3 Figure 3 and Table D.1.4, Appendix, Document B)

The age distribution for ONS data is as in the Table below, which shows that the largest group of patients include were older than 75 years old. This group is unlikely to be eligible for transplant in the UK.

Further to this, the ONS data cover 2017 for which we have no recruitment data from Myeloma XI. Assuming a constant number of diagnoses per year in the UK, the equivalent comparable number of ONS diagnoses has been calculated for the period 2013-2016.

Finally, the groups below 75 years old (slightly less than 22,500 in total) are far more likely to be comparable to the ASCT-eligible subpopulation in Myeloma XI.

In addition, the ONS data also include people from Myeloma XI who did not receive an ASCT because ineligible. Therefore, we have estimated the number of people in the ONS data that could be ASCT-eligible, in the Table below.

ONS Cancer survival estimates,

Age group (a)	Number of diagnoses (2013-2017) (b)	ONS estimated cases, 2013-2016 (c)	ONS, ASCT eligible (estimated, 30% of(c)) (d)	Myeloma XI randomised to lenalidomide in maintenance, 2013-2016 (e), (proportion of (d))
15-44	1,066	853	256	██████████
45-54	3,169	2,535	761	██████████
55-64	6,991	5,593	1,678	██████████
65-74	11,360	9,088	2,726	██████████
75-99	16,000	12,800	-	██████████
Total	38,586	30,869	5,421	██████████

When considering the equivalent number of diagnoses in the ONS data, limited to 4 years (2013-2016) and limited to the estimated proportion of people who are ASCT eligible (30%), the estimated proportion of cases in the ONS data that would have received maintenance in fact ██████████ including patients who received lenalidomide + vorinostat. This results in a non-negligible proportion of people in the ONS data who in fact received maintenance as part of Myeloma XI in the ASCT eligible group.

In addition, the ONS data also includes non-ASCT eligible people who received maintenance as part of the 'non intensive' cohort in Myeloma XI.

	<p>In conclusion, confounding is embedded in the ONS data which include mortality data for both ASCT and non ASCT eligible people who received maintenance in Myeloma XI. The impact of these two groups on survival estimates is likely to be in opposite directions: whilst data from non ASCT eligible people contribute to underestimation of the ONS estimate with reference to the model population in this Appraisal, the data contributed by people who received lenalidomide maintenance would imply an overestimate for the ONS data with reference to the *observation* arm in our model. It is not possible to judge whether the two opposite effects balance, and therefore it is not reasonable to conclude that the ONS data would constitute a lower bound for survival with observation. This proves that the ONS estimates for survival at 5 and 10 years do not constitute a reliable validation dataset for the observation group in this assessment.</p> <p>It is also unclear why a biased dataset should be preferred to data from specific groups in the observation arms in CALGB and in Myeloma XI, which have both a much longer follow-up (in excess of 5 and 10 years follow-up respectively) and importantly, provide unconfounded data, a far more reliable basis to estimate survival in the observation arm of the model.</p>
<p>e) Is it appropriate to use CALGB 100104 data to inform OS curve model selection? If so, was the company correct to choose the rank preserving structural failure time (RPSFT) method to adjust for treatment switching in CALGB 100104, and why?</p>	<p>We believe so for the reasons explained above.</p>
<p>f) Is there likely to be a waning of treatment effect with lenalidomide maintenance therapy? Or is the company's assumption of [REDACTED] more realistic?</p>	<p>The assessment of log-hazard plots (in agreement with the ERG assessment) shows that, the hazard is likely to remain proportional in the long term, therefore the possibility that the treatment effect for lenalidomide is waning is not corroborated by the data, by our and by the ERG's assessment.</p>
<p>Issue 7: Uncertain impact of dose adjustments and wastage on drug costs</p>	

<p>a) In clinical practice, what is the likely relative dose intensity (RDI) of lenalidomide maintenance, i.e. the estimated percentage of doses actually delivered out of those that are planned?</p>	<p>We reanalysed lenalidomide consumption data from Myeloma XI and obtained an RDI of approximately [REDACTED]. This is the compound result of treatment-free periods longer than the standard 7-days planned break between a cycle and another. In Myeloma XI, [REDACTED]. More details are provided in the Addendum (Section 2.2)</p>
<p>b) What are likely to be the main reasons to deviate from the recommended dosing of 10 mg per day on days 1 to 21 of a 28-day cycle (e.g. dose reduction, missed doses, etc.)?</p>	<p>There were a number of clinical and non-clinical reasons for deviating from the lenalidomide maintenance dosage schedule of 10mg on days 1 to 21 of a 28-day cycle in the Myeloma XI study.</p> <p>Patients may have had their dose reduced in various ways to manage toxicities, mainly haematological toxicities. The first dose reduction step as specified in the study protocol was to reduce the dose from 10mg to 5mg while maintaining the days on which treatment was given (i.e. D1-21/28 days). The second dose reduction step as specified in the study protocol was to give 5mg on alternate days for 21 out of 28 days.</p> <p>Other dosage regimens employed in Myeloma XI were to alternate between giving lenalidomide [REDACTED]. Other schedules included patients receiving [REDACTED] (see Addendum (Section 2.2))</p> <p>Other reasons for deviating from the recommended dosing schedule might have been because the patient needed a break from treatment due to a routine operation (e.g. hip replacement), or because they had requested a ‘drug holiday’ because they were going on holiday and wished to have their treatment suspended. It is important to remember that Myeloma XI was a pragmatic study and therefore closely reflects real-world clinical practice in the UK.</p>
<p>c) Should the RDI from the Myeloma XI trial ([REDACTED]) or TMM1 trial (95%) be used in the economic model?</p>	<p>The TMM1 (Tourmaline MM 1) was a study of ixazomib + lenalidomide + dexamethasone) in relapsed / refractory MM, and used the 25mg dose for lenalidomide. The intent of treatment for relapsed refractory patients is largely different than that of maintenance (aiming to prolong first remission) and therefore adherence and compliance with the treatment drug are not representative for that of lenalidomide used in maintenance. New estimates for the RDI in</p>

	Myeloma XI are provided in the Addendum and show that RDI in maintenance is substantially lower than 95%.
d) Are wastage costs appropriately accounted for?	We have reanalysed the Myeloma XI data and have incorporated real world data on wastage for maintenance with lenalidomide when used in clinical practice. The results of this reanalysis show an RDI of approximately [REDACTED]
Issue 8: Whether medical resource use should differ between treatments and between relapse status	
a) Is medical resource use likely to be the same between maintenance therapy with lenalidomide and observation? If not, how do they vary?	It is possible that participants on active maintenance treatment would receive more monitoring and would require prescription visits compared with people on observation. We have incorporated the ERG assumptions in the revised base case for the model.
b) Is medical resource use likely to be the same in the pre-progression and post-progression states? If not, how do they vary?	Treatments in post-progression states may be more intensive than in pre-progression because patients have relapsed, the disease has become more burdensome, patients get older and frailer (particularly because maintenance prolongs time to remission and therefore relapses occur at an older age in maintenance than in observation. Despite these reasons, we accept the ERG assumptions of equal resources.
c) Are the company's or ERG's estimates of medical resource use costs the most appropriate?	Please see above

Appendix A

Table 1: Adverse events in CALGB 100104 (Holstein et al. 2017)

Event ^{a,b} n, (%)	Lenalidomide (n=231)				Placebo (n=229)							
					Placebo (no crossover) (n=143)				Placebo (crossover) (n=86)			
	Grade 1	Grade 2	Grade 3	Grade 4	Grade 1	Grade 2	Grade 3	Grade 4	Grade 1	Grade 2	Grade 3	Grade 4
Haematologic												
Haemoglobin	15 (6)	6 (3)	9 (4)	2 (1)	3 (2)	3 (2)	0 (0)	0 (0)	1 (1)	1 (1)	1 (1)	0 (0)
Leukopenia	4 (2)	5 (2)	28 (12)	3 (1)	2 (1)	1 (1)	1 (1)	1 (1)	1 (1)	2 (2)	9 (10)	1 (1)
Lymphopenia	2 (1)	2 (1)	20 (9)	1 (<1)	1 (1)	1 (1)	1 (1)	1 (1)	1 (1)	1 (1)	5 (6)	0 (0)
Neutropenia	14 (6)	36 (16)	82 (35)	34 (15)	12 (8)	10	7 (5)	4 (3)	8 (9)	15 (17)	26 (30)	4 (5)
Thrombocytopenia	75 (32)	33 (14)	23 (10)	11 (5)	28 (20)	7 (3)	0 (0)	7 (5)	29 (34)	8 (9)	3 (3)	2 (2)
Non-haematologic												
Conduction abnormality	0 (0)	0 (0)	1 (<1)	0 (0)	0 (0)	0 (0)	0 (0)	0 (0)	0 (0)	0 (0)	1 (1)	0 (0)
Fatigue	10 (4)	9 (4)	0 (0)	0 (0)	5 (3)	1 (1)	0 (0)	0 (0)	4 (3)	4 (3)	0 (0)	0 (0)
Rash	22 (10)	22 (10)	9 (4)	0 (0)	10 (7)	7 (5)	1 (1)	0 (0)	5 (6)	5 (6)	1 (1)	0 (0)
Diarrhoea	54 (23)	36 (16)	12 (5)	0 (0)	15 (10)	3 (2)	2 (1)	0 (0)	9 (10)	9 (10)	3 (3)	0 (0)
Febrile neutropenia (fever of unknown origin)	54 (23)	0 (0)	14 (6)	0 (0)	1 (1)	0 (0)	2 (1)	1 (1)	1 (1)	1 (1)	1 (1)	0 (0)
Infection ^c	2 (1)	4 (2)	13 (6)	0 (0)	0 (0)	2 (1)	3 (2)	0 (0)	0 (0)	0 (0)	4 (5)	0 (0)
Infection with normal ANC or Grade 1/2 neutrophils	1 (<1)	4 (2)	3 (3)	0 (0)	0 (0)	3 (2)	3 (2)	0 (0)	1 (1)	1 (1)	1 (1)	0 (0)
Pain	0 (0)	0 (0)	0 (0)	1 (<1)	5 (3)	2 (1)	6 (4)	0 (0)	3 (3)	3 (3)	2 (2)	0 (0)
Vascular	0 (0)	0 (0)	0 (0)	0 (0)	0 (0)	0 (0)	0 (0)	0 (0)	0 (0)	0 (0)	0 (0)	0 (0)

Grade 5 AEs occurred in three patients. Lenalidomide (x2): Infection with normal ANC or Grade 1/2 neutrophils; vascular event. Placebo (x1): conduction abnormality.

^a Data cut-off Oct 2016, medium follow-up 91 months; ^b AEs reported in ≥ 10% of patients for grades 1-2 and ≥ 2 % of patients for grade 3-4 events; ^c Documented clinically or microbiologically.

ANC, absolute neutrophil count.

Adapted from: Holstein SA, et al. *Lancet Haematol.* 2017;4: e431-e442.

Table 2: Adverse events associated with treatment discontinuation in CALGB 100104¹ (Holstein et al. 2017 supplementary appendix)

Adverse event (AE)	Lenalidomide (n)	Placebo (no crossover) (n)	Placebo (crossover) (n)
Cytopenias	9		1
Neutropenia	2		1
Thrombocytopenia	4		1
Anaemia			1
Haemolytic anaemia			1
Infection	7		
Venous thrombosis	1		1
Pericarditis	1		
Supraventricular and nodal arrhythmia	1		
Coronary artery disease	1		
Diarrhoea	4		
Renal insufficiency	1		1
Creatinine phosphokinase	1		
Rash/desquamation	6		2
Pain	2		
Fatigue			1
Hypothyroid		1	
Stroke	1	1	1
Neuropathy	1	1	1
Seizures		1	
Dizziness		1	
Syncope	1		
Encephalopathy	1		
Ataxia	1*		1
Tremor			1
Total AEs**	45	5	14
Total number of persons	42	5	14

¹This study's off-treatment form did not require the sites to specify which adverse event led to treatment discontinuation, although in some cases this information was provided as a comment on the form. For those patients for whom such comments were not provided, chart review was performed to adjudicate the adverse event/s associated with treatment discontinuation. This review involved the utilisation of study adverse event reporting forms from the time period of treatment discontinuation, AdEERs reports, or primary source documents (i.e., clinic notes).

* This patient was subsequently suspected to have amyotrophic lateral sclerosis. ** A few patients had two adverse events which contributed to early study discontinuation.

Table 3: Second primary malignancies in CALGB 100104 (Holstein et al. 2017)

	Lenalidomide (n=231)	Placebo	
		Crossover (n=86)	No-crossover (n=143)
Haematological SPM	18 (8%) Myelodysplastic syndrome or acute myeloid leukaemia (n=10); B-cell acute lymphoblastic leukaemia (n=6); Hodgkin's lymphoma (n=1); Waldenstrom macroglobulinaemia (n=1)	3 (3%) B-cell acute lymphoblastic leukaemia (n=2); myelodysplastic syndrome (n=1)	None
Solid tumour SPM	14 (6%) Breast (n=3); colon (n=3); prostate (n=2); endometrial (n=2); glioblastoma multiforme (n=1); melanoma (n=1); papillary thyroid (n=1); salivary gland carcinoma (n=1)	5 (6%) Melanoma (n=2); endometrial (n=1); renal cell (n=1); invasive squamous cell carcinoma (n=1)	4 (3%) Breast (n=1); melanoma (n=1); ovarian and endometrial (n=1); lung carcinoid (n=1)
Non-invasive SPM	11 (5%) Squamous cell carcinoma (n=5); basal cell carcinoma and squamous cell carcinoma (n=3); ductal carcinoma in situ (n=2); basal cell carcinoma (n=1)	5 (6%) Basal cell carcinoma (n=3); basal cell carcinoma and squamous cell carcinoma (n=2)	1 (<1%) Squamous cell carcinoma (n=1)

References:

Palumbo A. Autologous transplantation and maintenance therapy in multiple myeloma. *New Eng J Med* 2014; 371: 895-905.

Holstein SA, et al. *Lancet Haematol.* 2017;4: e431-e442 and supplementary appendix.

Jones JR et al. Second malignancies in the context of lenalidomide treatment: an analysis of 2732 myeloma patients enrolled to the Myeloma XI trial. *Blood* 2016;

NICE guideline. Myeloma: diagnosis and management. February 2016. Available at: <https://www.nice.org.uk/guidance/ng35> (accessed July 2020)

NICE. Lenalidomide plus dexamethasone for multiple myeloma after 1 treatment with bortezomib. TA586. June 2019. Available at: <https://www.nice.org.uk/guidance/ta586> (accessed July 2020)

NICE. Carfilzomib for previously treated multiple myeloma. TA457. July 2017. Available at: <https://www.nice.org.uk/guidance/ta457> (accessed July 2020)

Addendum A: Pooling of CALGB and Myeloma XI

Within the original parametric survival analysis of OS and PFS for Myeloma XI, the CALGB study which provided longer-term data was used to provide external validation for the selected parametric curves. However, given individual patient level data were available for the CALGB study as well, we more formally incorporated the long-term data from the CALGB study into the parametric survival analysis.

Parametric survival curves were then fitted to the combined data for Myeloma XI (n=621 maintenance, n=411, observation) and CALGB (n=231 maintenance, n=229 observation). The pooled analyses used fixed effects covariates for treatment (lenalidomide or observation/placebo) and study. The inclusion of a fixed effect covariate for the trials within these analyses maintains the randomisation within the two studies and allows adjustment for differences between the studies. The analysis therefore allows PFS and OS to be estimated for the Myeloma XI population whilst considering the longer-term data from the CALGB study.

There were only a limited number of common baseline characteristics between the studies (Table 1). These were not adjusted for as the CALGB baseline values were recorded after ASCT and in Myeloma XI recording was performed at diagnosis (i.e. before induction and ASCT). Additional details of patient composition can be found in the primary publication for CALGB (Holstein et al, 2017) and in Appendix D of Document B.

Table 1: Baseline characteristics – CALGB and Myeloma XI

	CALGB	Myeloma XI
Number of patients	460	
Mean age	57.22	
Age <60	57.39%	
Female	45.65%	
ISS post ASCT I/II	55.87%	
ISS post ASCT III	16.52%	
ISS post ASCT Missing	27.61%	

For the purposes of predicting outcomes in the model, and for consistency with the decision problem, predictions in the economic model are made assuming 100% of patients are Myeloma XI patients. Specifically, the 'Myeloma XI (vs CALGB)' coefficient is used for all predictions. This allows for prediction of outcomes for the Myeloma XI cohort whilst allowing for long-term trends in OS and PFS to be informed by the longer follow-up available in CALGB. The new base case presented in this document therefore relies on extrapolations for Myeloma XI OS and PFS using the pooled model.

Log cumulative hazard plots for the pooled model, stratified by study and treatment arm, are illustrated in Figure 1 and Figure 2 for overall survival (OS) and progression free survival (PFS), respectively. For both OS and PFS, lines are straight and parallel, suggesting the hypothesis of proportional hazards cannot be rejected between both treatment arms (lenalidomide vs observation) and study (Myeloma XI vs CALGB). Treatment (lenalidomide vs observation) and study (Myeloma XI vs CALGB) were therefore included in the statistical models, and 'independent' models were not estimated for the pooled analysis (though are retained in the model).

Figure 1: Log cumulative hazard of OS; Myeloma XI and CALGB

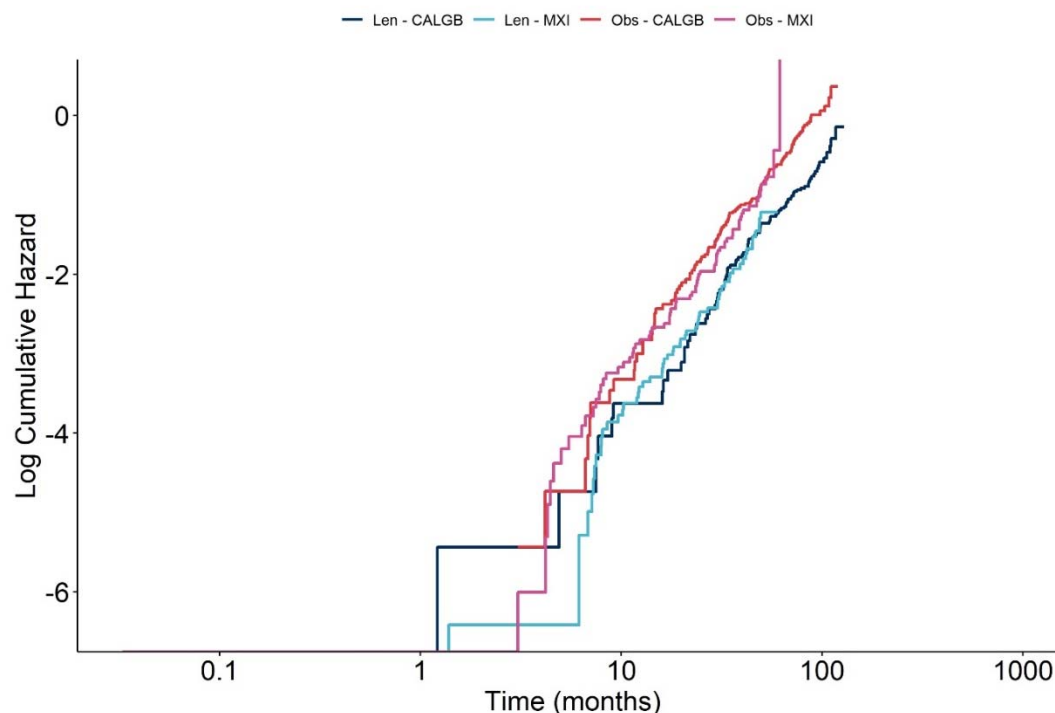

Abbreviations: Len, lenalidomide; MXI, Myeloma XI; Obs, observation; OS, overall survival.

Figure 2: Log cumulative hazard of PFS; Myeloma XI and CALGB

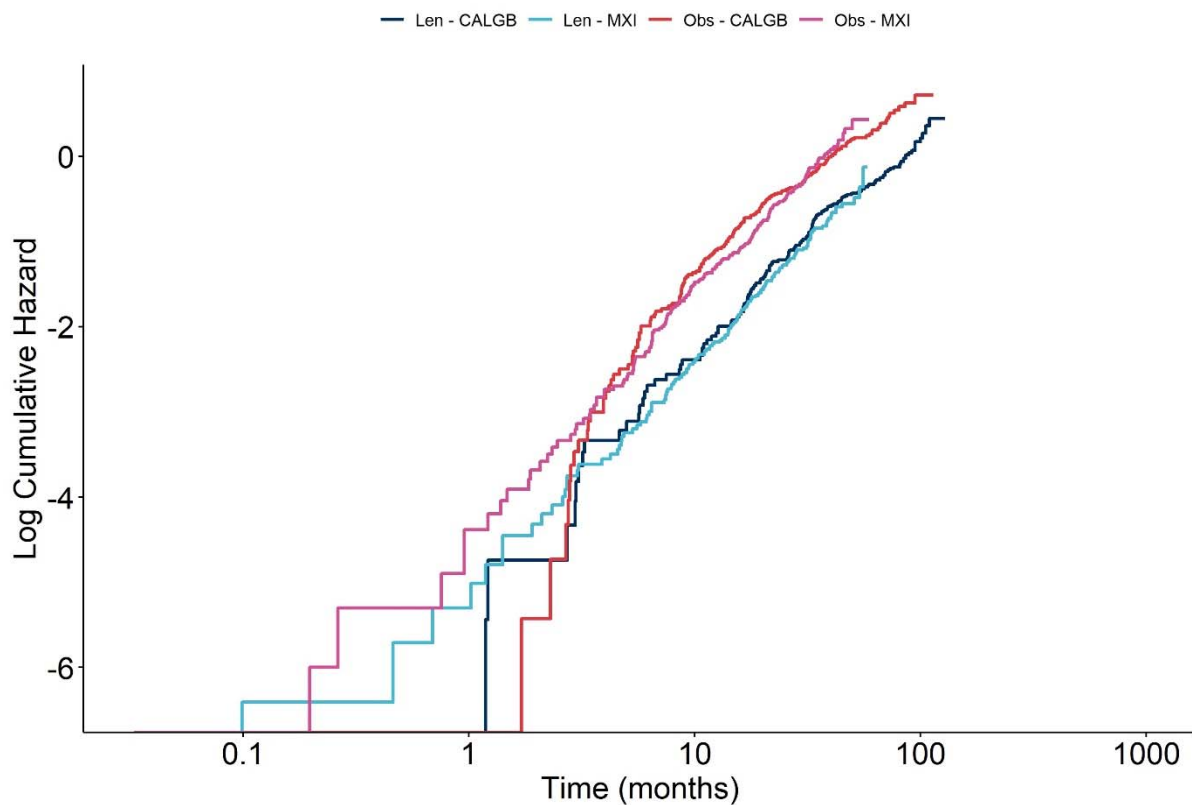

Abbreviations: Len, lenalidomide; MXI, Myeloma XI; Obs, observation; PFS, progression free survival.

Model fit diagnostics are reported in Table 2. Based on minimising the Akaike Information Criterion (AIC):

- Weibull, log-logistic, and generalised gamma distributions perform similarly well for OS
- The log-logistic and generalised gamma model are the best fitting curves for PFS.

Table 2: Model fit diagnostics for pooled Myeloma XI and CALGB analysis

Model	OS		PFS	
	AIC	BIC	AIC	BIC
Exponential	4072.266	4088.19	6533.252	6549.175
Weibull	4015.97	4042.51	6524.197	6545.429
Lognormal	4025.721	4052.261	6528.531	6549.762
Log-logistic	4016.577	4043.116	6505.519	6526.75
Gompertz	4039.594	4066.133	6535.015	6556.247
Generalised gamma	4016.104	4047.951	6509.331	6535.871

Abbreviations: AIC, Akaike Information Criterion; BIC, Bayesian Information Criterion; OS, overall survival; PFS, progression free survival.

Comparison of each distribution to the observed data to allow for visual inspection are presented in **Error! Reference source not found.** and **Error! Reference source not found.** for OS and PFS, respectively.

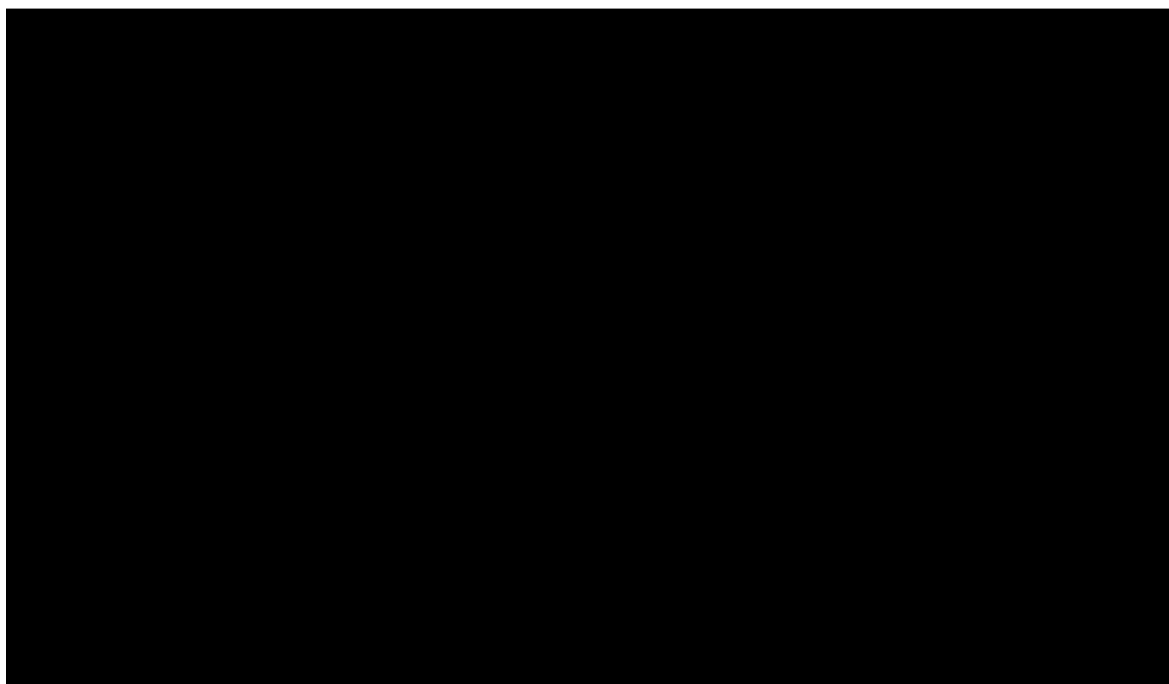
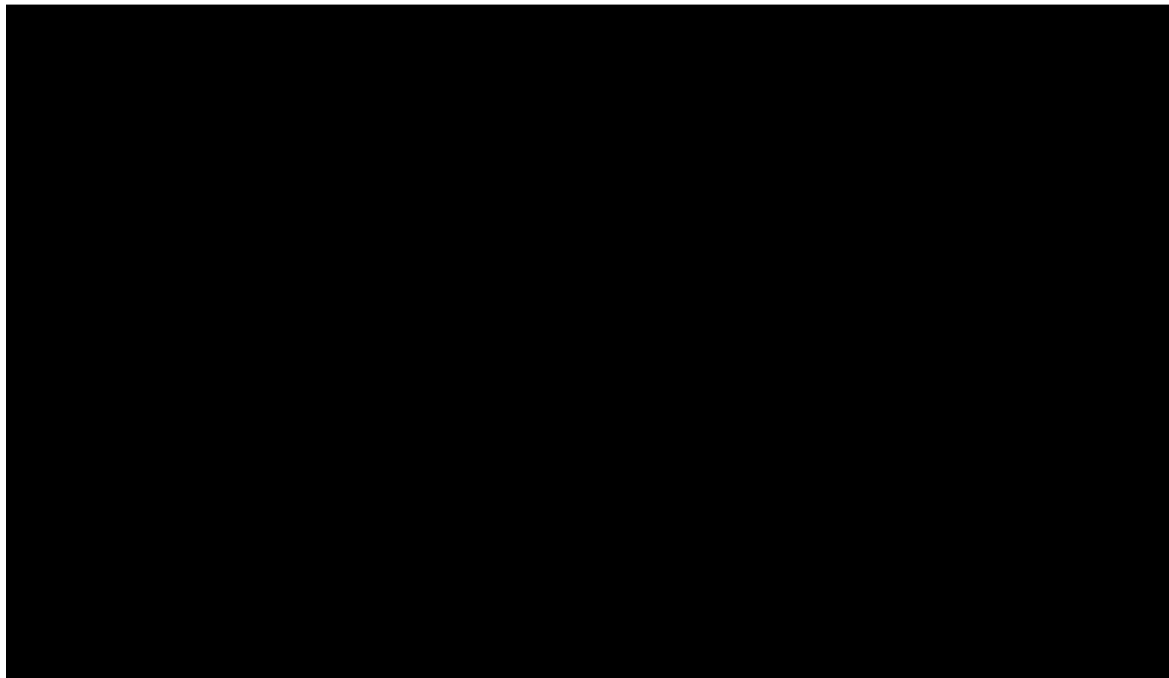

On the basis of the model diagnostics presented in Table 2 and visual inspection for OS (**Error! Reference source not found.**) the Weibull and generalised gamma distribution were selected as the base-case for OS and PFS, respectively.

For OS, the Weibull is one of the best fitting curves according to statistical goodness of fit. The comparison against the observed data, specifically the longer-term data available from CALGB, suggest that, if a single model is to be selected to represented both lenalidomide and observation arm, the Weibull distribution fits both the Myeloma XI and the CALGB Kaplan Meier. The Weibull also provided the best fit over the longer term to existing data, whilst the generalised gamma underestimated both lenalidomide maintenance and observation and the log logistic had a reasonable fit to the lenalidomide maintenance data but overestimated observation (Figure 5 below).



For PFS, the generalised gamma was the distribution which fitted the data more closely (Figure 6 below)



All other distributions were retained for scenario analysis. Please note that when considering the constancy of treatment effect, models estimated in the accelerated failure time (AFT) metric, such as the log-logistic or log-normal models, incorporate the proportional odds, and not proportional hazards assumption; therefore for these models constancy of treatment effect should be considered on these terms.

Results in terms of cost-effectiveness including the impact of incorporating the new analysis are reported in Addendum C in this document.

Addendum B: Economic model changes

Changes to the economic model described in this addendum were made to the model submitted in response to Evidence Review Group (ERG) clarification questions.

1. Minor changes

Minor changes were incorporated to align with the ERG preferred base-case assumptions (as per Section 6.3 of the ERG Report). These changes were not included as formal options within the model, as only input changes were required.

- The re-weighting undertaken to omit CDF regimens from the UK Clinician Survey results was updated to exclude patients not receiving treatment and to only include the proportion of patients that were expected to receive any subsequent treatment before and after the removal of CDF drugs (as suggested on page 79 of the ERG Report)
- Set cost of "other" treatments equivalent to CTD regimen
- Set cost of bortezomib from eMIT
- Set MRU costs post-relapse same as pre-relapse and halve pre-relapse outpatient visits for observation.

2. Analysis based on pooling of CALGB and Myeloma XI

The model was updated to choose extrapolation of outcomes based on the pooled CALGB and Myeloma XI analysis described in Addendum A. The previous base case was retained in the model and can be selected via a drop-down menu.

A new sheet containing the pooled data has been included ('Clinical data (MXICALGB)'); one further sheet with extrapolations for each distribution has been added ('Extrapolations (MXICALGB)'). Please note that independent statistical models were not estimated for the pooled CALGB and Myeloma XI analysis, therefore independent model options are not available when the new base case is selected.

2.1. Distribution of subsequent therapies

As described in our response to the Technical Engagement, in order to further explore subsequent therapies, we obtained clinical validation for both the prior distribution used in the original model and the reweighted distribution presented in this model.

The additional data has been added to the 'Cost data' sheet of the economic model. The use of this distribution is chosen through a new 'drop down' menu. Table 3 summarises the revised subsequent therapy data.

Table 3: Revised subsequent therapy data included in the model

Treatment	Lenalidomide 1st relapse	Observation 1st relapse	Lenalidomide 2nd relapse	Observation 2nd relapse
Lenalidomide + dexamethasone	████████	████████	████████	████████
Bortezomib + dexamethasone	████████	████████	████████	████████
Carfilzomib + dexamethasone	████████	████████	████████	████████
Panobinostat + bortezomib + dexamethasone	████████	████████	████████	████████
Autologous transplant	████████	████████	████████	████████
Other	████████	████████	████████	████████
No treatment	████████	████████	████████	████████

Daratumumab, daratumumab + bortezomib + dexamethasone, pomalidomide, bendamustine, ixazomib + lenalidomide + dexamethasone, as well as allograft, thalidomide + melphalan + prednisolone and conventional chemotherapy are now excluded from subsequent costs.

2.2. Relative dose intensity (RDI)

Additional analyses of drug consumption data Myeloma XI data were performed in order to incorporate the impact of non-linearity for the price of lenalidomide 10mg and 5mg dosages, as well to incorporate the results from Myeloma XI data with regards to treatment-free intervals and drug wastage.

Anonymised cycle-specific patient-level data collected in the Myeloma XI model cohort collected under study protocol V5 and V6 were analysed to estimate the use of both 10mg and 5mg doses and establish the RDI for each dose.

cumulative dose received over the trial was obtained from the sum of total doses per cycle. The number of packs consumed was calculated using the total cumulative dose divided by 210 (10mg) or 105 (5mg) and rounded to the next multiple of 210 or 105. Patients who were treated for one cycle only were assumed to receive one pack of 210mg, regardless of whether the dose reported was equal or less than 210mg.

Wastage was assumed for all patients who did not have regular 210mg or 105mg total doses per cycle, assigning a full drug pack to all last cycles for a patient, or to patients who had a change in dose from 10mg to 5mg. For cycles that were less than 210mg or 105mg, with no daily dose changed, carry over was assumed as there is no reason to assume that packs would be discarded if they could be reused the next cycle. An exception would be when the last cycle of one dose was followed by a change in dose in the absence of re-escalation to a higher dose. In these cases, a whole pack was counted to include wastage.

For people who had cycles that fell under any of the assumptions below, additional wastage was assigned, reflecting several possible combinations of doses, days exposed, and packs dispensed:

- For patients who had less than 105mg total doses in multiples of 10, total number of packs were calculated rounding to the next integer because, in the assumption of carry over, the equivalent number of pills would be discarded in the last cycle and would therefore still count as wastage. Similarly, for patients with a total dose lower than 105mg and multiple of 5mg.
- Some patients received [REDACTED] with no dose reported. These cases were interpreted as [REDACTED]. The doses were assumed the same as in the prior cycles for that patient, and either imputed as full pack if the patient resumed to a regular cycle pattern with a different dose, or treatment discontinued, or carried over if cycles with less doses followed. Wastage was assumed for these patients.
- Some patients also received [REDACTED] of active treatment, with the same dose, in which case carry-over was assumed.
- Three patients had [REDACTED] consecutively, after a series of cycles at 105mg. [REDACTED]

- Six cycles were classified as 'not per protocol' but no further information was available on the type of change, therefore they were assigned a 'per protocol' dose (210mg 21/28).
- If no dose was reported for the last cycle then the dose of the prior cycle was imputed, treatment was then assumed to be discontinued.

Missed doses were reported for some patients:

- One patient had 3 consecutive doses missing, including their last cycle. It was assumed that they received 210mg as per regular treatment.
- For patients with missing doses during intermediate cycles it was assumed that the same dose as for the adjacent cycles applied. Only one patient had a different dose prior to and after the missing value, therefore the highest dose was imputed.

For cycles which did not have a start date, the following approach was taken:

- Regular pattern [REDACTED] If a patient had received prior regular cycles and had only one missing date, a regular cycle was assumed (21/28 days), conservatively.
- [REDACTED] and no start date [REDACTED] For patients with no start date who received only one cycle, it was assumed that their start date was the first cycle in the data set [REDACTED]

All other missing cycle dates [REDACTED]: a 28 days regular cycle was assumed.

Finally, we assumed that all packs dispensed were of 21 daily doses for both 10mg and 5mg. Although lenalidomide 10mg and 5mg is also available in packs of 7 daily doses, we did not consider these packs in the calculation of RDI as doing so would require assumptions on physicians' dispensing behaviours. In real practice, it is possible that 7 daily doses packs would be dispensed, limiting wastage. The approach in this analysis therefore should be considered conservative.

2.2.3. Calculation of RDI

The RDI for lenalidomide maintenance was calculated separately for the 10mg and the 5mg cycles. Once all doses per cycle were imputed, we calculated the total follow up for each patient spent on cycles during which a 10mg or a 5mg dose was

used. For mixed cycles (i.e. [REDACTED]) we used the entire duration of each cycle given that in practice, mixed therapies would require less packs for each dose separately, therefore impacting the total exposure to each dosage.

Once the total real time spent on each dose was calculated, we calculated the hypothetical maximum total dose that would be required to cover the same period based on regular 210mg cycles in 28 days, or regular 105mg in 28 days cycles. We then calculated the RDI dividing the real cumulative doses per patient by the hypothetical total required if the patient were fully compliant with the 210mg (or 105mg) dosage and regular 21/28 days use.

We applied the RDI in the model separately for 10mg and 5mg, as a weighted average of RDI and proportion of cycles on 10mg and on 5mg from the Myeloma XI data.

2.2.4. Results

The Myeloma XI dataset included [REDACTED] in total. The results of the analysis, for the 10mg, the 5mg dose and the RDIs for each dose, are described in Table 5.

Table 5: Results of the RDI analysis

Result	10mg dose	5mg dose
N	[REDACTED]	[REDACTED]
Total number of cycles (%) including dosage of 10mg/5mg	[REDACTED]	[REDACTED]
RDI (SD)	[REDACTED]	[REDACTED]
Mean number of cycles (SD) per patient	[REDACTED]	[REDACTED]
Mean cycle length (including 7 days treatment-free period) (SD, min-max)	[REDACTED]	[REDACTED]

The use of the revised analysis (as opposed to the initial estimate of the RDI) is incorporated using a 'drop down' menu, with the new data presented on the 'Cost data' sheet of the economic model.

3. Results, cumulative impact of changes on the ICER

Table 6 presents results of model changes A full revised results section is presented in Addendum C.

Table 6: Results of model changes

Model setting(s)	Section	ICER
Base-case (as per version sent in response to ERG clarifications)	N/A	██████
Redistribute CDF in the UK Clinician Survey to exclude "No treatment"	1.1	██████
Use eMIT price for bortezomib		██████
Set MRU costs post-relapse same as pre-relapse		██████
Halve pre-relapse outpatient visits for observation		██████
Use Pooled CALGB and Myeloma XI analysis (same distributions as base-case)	2	██████
New estimates of subsequent therapies	2.1	██████
Revised RDI analysis	2.2	██████

Abbreviations: CTD, cyclophosphamide + thalidomide + dexamethasone; eMIT, electronic market information tool; ERG, Evidence Review Group; ICER, incremental cost-effectiveness ratio; OS, overall survival; PFS, progression free survival; RDI, relative dose intensity.

Addendum C: Revised economic model results (B3.6 of form B)

4. Base-case incremental cost-effectiveness analysis results

In the base-case analysis, lenalidomide is associated [REDACTED]
 [REDACTED]
 [REDACTED] xxxxxxxx xxxxxxxxxxxx [REDACTED]
 [REDACTED]
 [REDACTED]

Table 7).

The cost-effectiveness is driven by the QALY gain based on long-term extrapolation of OS from Myeloma XI using the new Myeloma XI and CALGB pooled analysis, together with the offsetting of subsequent therapy costs [REDACTED]
 [REDACTED]

The base-case includes:

- [REDACTED]
 [REDACTED]
- [REDACTED]
 [REDACTED]

[REDACTED]

Table 7. Base-case results

Treatments	Total costs (£)	Total LYG	Total QALYs	Incremental costs (£)	Incremental LYG	Incremental QALYs	ICER (£/QALY)
Observation	[REDACTED]	[REDACTED]	[REDACTED]	[REDACTED]	[REDACTED]	[REDACTED]	[REDACTED]
Lenalidomide	[REDACTED]	[REDACTED]	[REDACTED]	[REDACTED]	[REDACTED]	[REDACTED]	[REDACTED]

Abbreviations: observation, best supportive care; ICER, incremental cost-effectiveness ratio; LYG, life years gained; QALY, quality-adjusted life year.

5. Sensitivity analyses

5.1. Probabilistic sensitivity analysis

Probabilistic sensitivity analysis (PSA) was performed varying all inputs simultaneously over 1,000 iterations, based upon their respective distributions. The results are presented on a cost-effectiveness plane (Figure 3) and as a cost-effectiveness acceptability curve (CEAC; Figure 4). The probability that lenalidomide was cost-effective at thresholds of £30,000 and £20,000 per QALY gained was

████████████████████

Table 8. Probabilistic incremental cost-effectiveness analysis results (with PAS)

Treatment	Total costs (£)	Total QALYs	Incremental costs (£)	Incremental QALYs	ICER (£/QALY)
Observation	██████████	██████			
Lenalidomide	██████████	██████	██████████	██████	██████████

Abbreviations: ICER, incremental cost-effectiveness ratio; QALY, quality-adjusted life year.

Figure 3. Cost-effectiveness plane

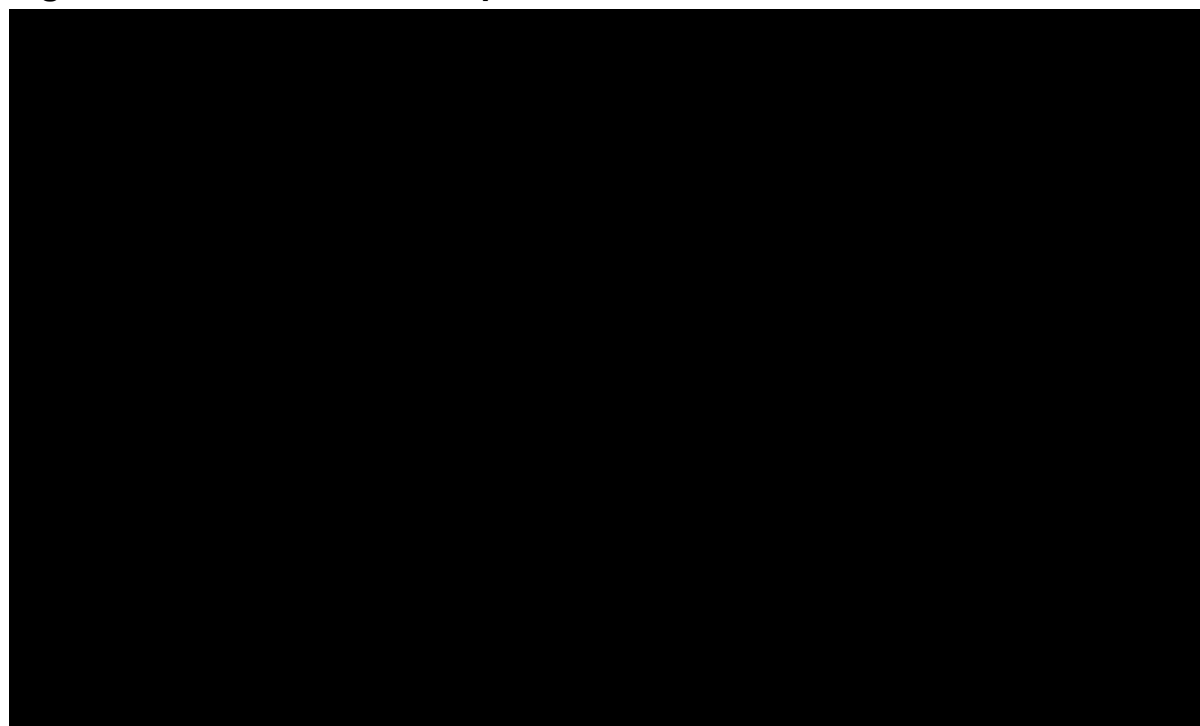

Abbreviations: QALY, quality-adjusted life year.

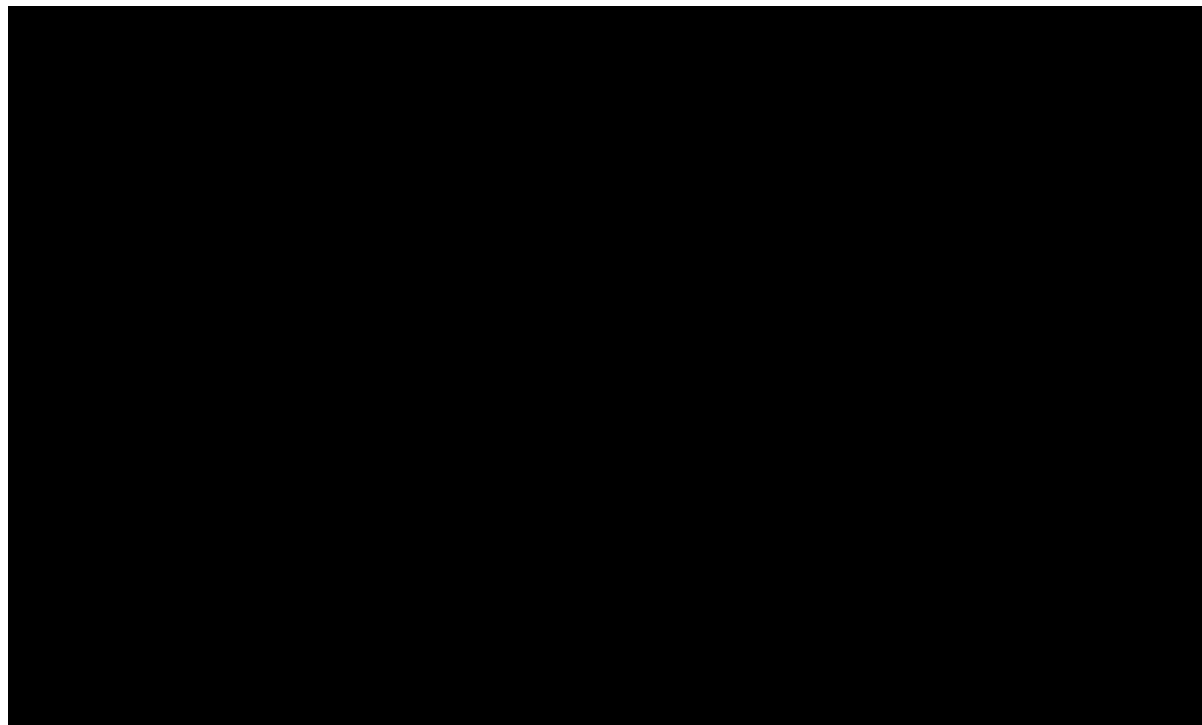
Figure 4. Cost-effectiveness acceptability curve**5.2. Deterministic sensitivity analysis**

A series of deterministic sensitivity analyses were performed to evaluate the parameter uncertainty of individual inputs, holding all else constant. Where available, 95% confidence intervals (CIs) were used to inform this range; these were either as reported or calculated based on standard errors or standard deviations and subject numbers. When such information was not available, an arbitrary range of $\pm 15\%$ of the base-case value was used. Figure 5 presents a tornado diagram with parameters shown in descending order of impact on the net monetary benefit (NMB). NMB was presented rather than the ICER to allow for results that are not associated with both increased costs and increased QALYs. The NMB is defined as:

$$NMB = \Delta QALYs \lambda - \Delta Costs$$

Where $\Delta Costs$ and $\Delta QALYs$ are the incremental costs and QALYs associated with lenalidomide, respectively, and λ represents the willingness to pay for a QALY; the willingness-to-pay threshold was assumed to be £30,000 per QALY for the UK base-case. A positive NMB indicates that lenalidomide is cost-effective at the willingness-to-pay threshold (conversely, a negative NMB would suggest lenalidomide is not cost-effective at a given willingness-to-pay threshold).

Figure 5. Results of one-way sensitivity analysis

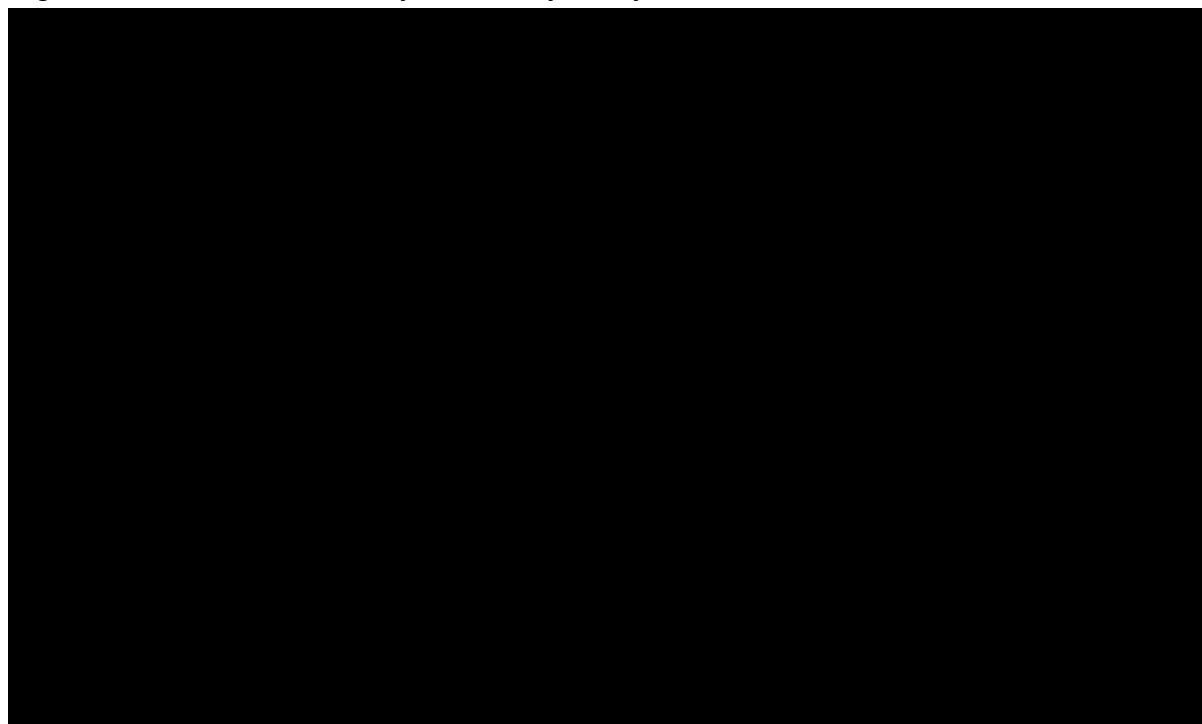

The parameters with the greatest impact on model outcomes relate to [REDACTED]
 [REDACTED]
 [REDACTED]

5.3. Scenario analysis

The results of scenario analysis results are provided in Table 9. The use of Myeloma XI instead of the UK Clinician Survey provides an ICER of [REDACTED]
 [REDACTED] Similarly, a highly conservative scenario in which all subsequent therapy costs are removed from both arms of the model [REDACTED]
 [REDACTED] reflecting the importance of subsequent therapies in the calculation of the cost-effectiveness ratio.

Table 9. Scenario analysis results

Scenario	Incremental costs	Incremental QALYs	ICER
<u>Base-case</u>	[REDACTED]	[REDACTED]	[REDACTED]
<u>Time horizon: 5 years</u>	[REDACTED]	[REDACTED]	[REDACTED]
<u>Time horizon: 10 years</u>	[REDACTED]	[REDACTED]	[REDACTED]
<u>Time horizon: 20 years</u>	[REDACTED]	[REDACTED]	[REDACTED]
<u>Hatswell utilities</u>	[REDACTED]	[REDACTED]	[REDACTED]
<u>Discount rate: 1.5% benefits, 6% costs</u>	[REDACTED]	[REDACTED]	[REDACTED]

6. PRISMA diagram – systematic review of health-related quality of life (HRQoL) and utility weights

In this section, the update systematic review of utility data is reported. We re-screened the search results and provide an updated PRISMA diagram in this Section. We also clarified the final list of papers included. The results of the selection is unchanged and some of the original clarifications required during the ERG report stage are provided here below.

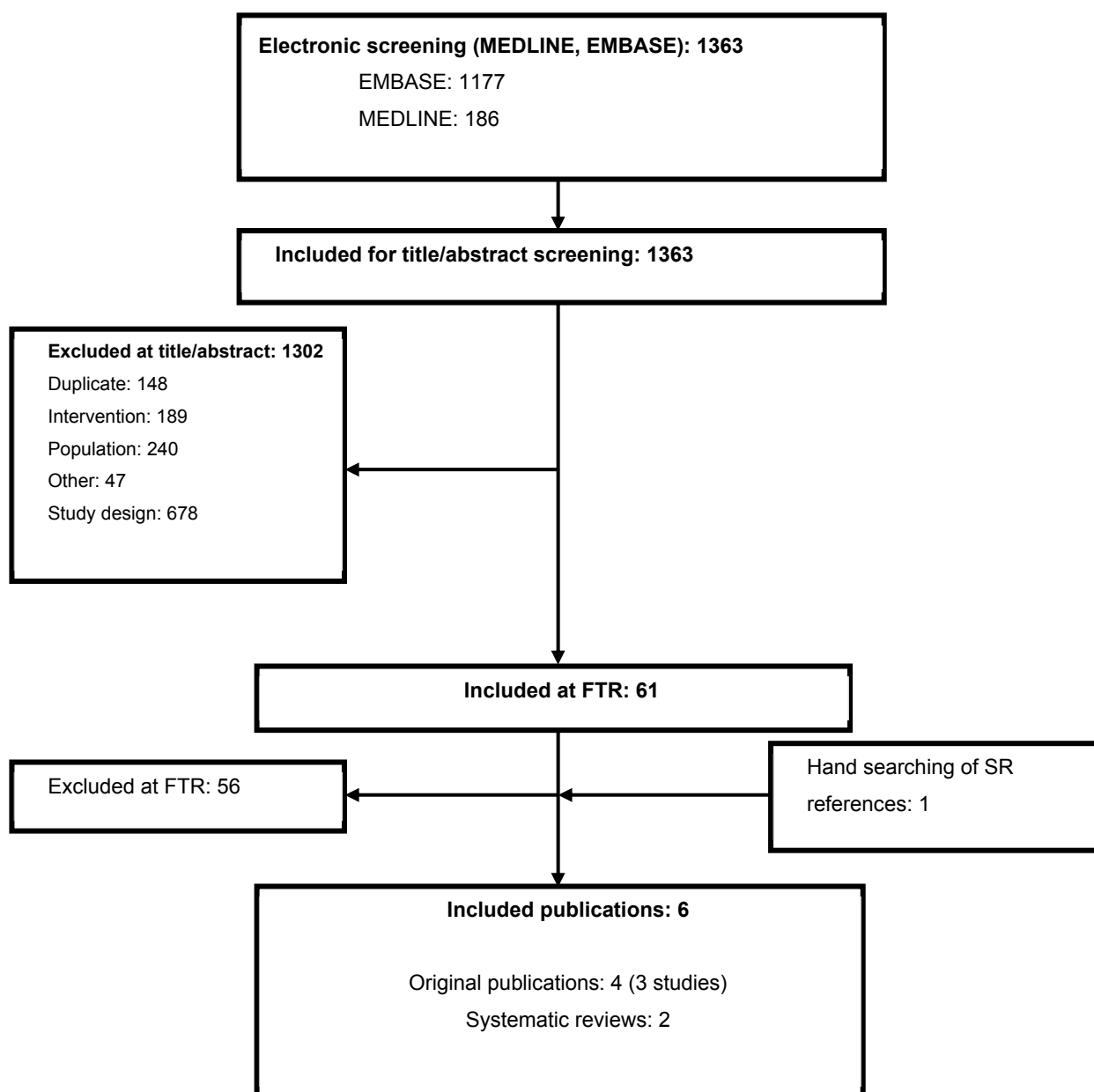

6.1. Included publications

Study	Authors	Year	Title	Journal	Citation
CONNECT MM disease registry	Abonour	2016	Health-related quality of life of patients with newly diagnosed multiple myeloma receiving any or lenalidomide maintenance after autologous stem cell transplant in the Connect MM disease registry	<i>Leuk Lymphoma</i>	60:5:1275–82
	Abonour	2018	Impact of post-transplantation maintenance therapy on health-related quality of life in patients with multiple myeloma: Data from the Connect MM registry	<i>Ann Hematol</i>	97:2425–36.
	Acaster	2013	Impact of the treatment-free interval on health-related quality of life in patients with multiple myeloma: A UK cross-sectional survey.	<i>Support Care Cancer</i>	21:599–607.
	Tay	2019	Health related quality of life for multiple myeloma patients according to treatment strategy after autologous stem cell transplant: A cross-sectional study using eortc, eq-5d and my-20 scales	<i>Leuk Lymphoma</i>	60:1275–82.
Systematic reviews	Hatswell	2019	Frequentist and bayesian meta-regression of health state utilities for multiple myeloma incorporating systematic review and analysis of individual patient data	<i>Health Economics</i>	28:653–65.
	Nielsen	2017	A systematic review of health-related quality of life in longitudinal studies of myeloma patients	<i>Eu J Haematol</i>	99:3–17.

6.2. Hand searching of the bibliographies of systematic reviews

Hatswell <i>et al</i> , 2019					
Authors	Year	Title	Journal	Citation	Rationale
Include					
Acaster	2013	Impact of the treatment-free interval on health-related quality of life in patients with multiple myeloma: A UK cross-sectional survey.	<i>Supportive Care Cancer</i>	2:599–607.	N/A
Exclude					
Ashaye	2015	Estimating EORTC-8D health state utility values from EORTC QLQ-C30	<i>Value Health</i>	18:A468.	Population

		scores in relapsed multiple myeloma.			
Ashaye	2015	Mapping utility scores from European organization for treatment of cancer core-30 questionnaire scores (EORTC QLQ-C30) in relapsed multiple myeloma.	<i>Value Health</i>	18(3):A208.	Population
Crott	2013	An assessment of the external validity of mapping QLQ-C30 to EQ-5D preferences. <i>Quality of Life Research</i> ,	<i>Qual Life Res</i>	22:1045–54.	Population
Delea	2012	Cost-effectiveness of zoledronic acid compared with clodronate in multiple myeloma.	<i>Current Oncol</i>	19:e392–403.	Study design, intervention, population
Delforge	2015	Health-related quality of life in patients with newly diagnosed multiple myeloma in the FIRST trial: Lenalidomide plus low-dose dexamethasone versus melphalan, prednisone, thalidomide.	<i>Haematologica</i>	100:826–833.	Population
Kharroubi	2015	Use of Bayesian Markov chain Monte Carlo methods to estimate EQ-5D utility scores from EORTC QLQ Data in myeloma for use in cost-effectiveness analysis.	<i>Med Decis Making</i>	35:351–60.	Population
Mohty	2015	Frontline therapy for multiple myeloma (MM) in real-world clinical practice: results from the third interim analysis of the multinational, non-interventional, observational EMMOS study.	<i>Clin Lymphoma Myeloma Leuk</i>	15:e127–8.	Outcomes
Naik	2014	Canadian cancer site-specific health utility values: Creating the basis for measuring value and costs of therapy.	<i>Am Soc Clin Oncol</i>	32:7.	Population
Palumbo	2013	Diagnosis and therapy of multiple myeloma.	<i>Korean J Intern Med</i>	28:263–73.	Outcome
Proskorovsky	2014	Mapping EORTC QLQ-C30 and QLQMY20 to EQ-5D in patients with multiple myeloma.	<i>Health Qual Life Outcome</i>	12:35.	Population

Quinn	2015	Mapping health state utility values from EORTC data collected from a clinical trial population with relapsed/refractory multiple myeloma.	<i>Value Health</i>	18:A468.	Population
Richardson	2005	Bortezomib continues demonstrates superior efficacy compared with high-dose dexamethasone in relapsed multiple myeloma: Updated results of the APEX trail.	<i>Blood</i>	106:2547.	Population
Uyl-de Groot	2005	Health related quality of life in patients with multiple myeloma undergoing a double transplantation.	<i>Eu J Haem</i>	74(2), 136–43.	Population
Nielson et al, 2017					
Authors	Year	Title	Journal	Citation	Rationale
Exclude					
Delforge	2015	Health-related quality-of-life in patients with newly diagnosed multiple myeloma in the FIRST trial: lenalidomide plus low-dose dexamethasone versus melphalan, prednisone, thalidomide.	<i>Haematologica</i>	100:826–33	Identified and excluded in electronic searches
Delforge	2012	Health- related quality of life in elderly, newly diagnosed multiple myeloma patients treated with VMP vs. MP: results from the VISTA trial.	<i>Eur J Haematol</i>	89:16–27.	Patient population
Dimopoulos	2015	Lenalidomide, melphalan, and prednisone, followed by lenalidomide maintenance, improves health-related quality of life in newly diagnosed multiple myeloma patients aged 65 years or older: results of a randomized phase III trial.	<i>Haematologica</i>	98(5):784–8	Identified and excluded in electronic searches
Dubois	2006	Descriptive and prognostic value of patient-reported outcomes: the bortezomib experience in relapsed and refractory multiple myeloma.	<i>J Clin Oncol</i>	24:976–82.	Population
Etto	2011	Autologous stem cell transplantation improves quality of life in economically challenged, Brazilian multiple myeloma patients.	<i>Clinics</i>	66:1855–9.	Intervention

Frödin	2011	A prospective evaluation of patients' health- related quality of life during auto-SCT: a 3- year fol-low- up	<i>Bone Marrow Transplant</i>	46(10):1345–52.	Identified and excluded in electronic searches
Gimsing	2010	Effect of pamidronate 30 mg versus 90 mg on physical function in patients with newly diagnosed multiple myeloma (Nordic Myeloma Study Group): a double- blind, randomised controlled trial.	<i>Lancet Oncol</i>	11:973–82.	Identified and excluded in electronic searches
Gulbrandsen	2001	Health-related quality of life in multiple myeloma patients receiving high-dose chemotherapy with autologous blood stem-cell support.	<i>Med Oncol</i>	18:65–77.	Population
Hjorth	2012	Thalidomide and dexamethasone vs. bortezomib and dexamethasone for melphalan refractory myeloma: a randomized study.	<i>Eur J Haematol</i>	88:485–96.	Population
Khalafallah	2011	Quality of life assessment in multiple myeloma patients undergoing dose- reduced tandem autologous stem cell transplantation.	<i>J Hematol Infect Dis</i>	3:e2011057.	Population
Lee	2008	Bortezomib is associated with better health- related quality of life than high-dose dexameth-asone in patients with relapsed multiple myeloma: results from the APEX study.	<i>Br J Haematol</i>	143:511–9.	Population
Ludwig	2013	Randomized phase II study of bortezomib, thalidomide, and dexamethasone with or without cyclo-phosphamide as induction therapy in previously untreated multiple myeloma.	<i>J Clin Oncol</i>	31:247–55.	Intervention
Mellqvist	2013	Bortezomib consolidation after autologous stem cell transplantation in multiple myeloma: a Nordic Myeloma Study Group randomized phase 3 trial	<i>Blood</i>	121(23): 4647–4654.	Intervention
Mols	2012	Health-related quality of life and disease-specific complaints among multiple myeloma patients up to 10 yr after diagnosis: results from a	<i>Eur J Haematol</i>	89:311–19	Intervention

		population-based study using the PROFILES registry.			
Moreau	2016	Oral ixazomib, lenalidomide, and dexamethasone for multiple myeloma.	<i>N Engl J Med</i>	1621–34.	Identified and excluded in electronic searches
Sirohi	2007	An open, randomized, controlled, phase II, single centre, two- period cross- over study to compare the quality of life and toxicity experienced on PEG interferon with interferon- alpha2b in patients with multiple myeloma maintained on a steady dose of interferon- alpha2b.	<i>Ann Oncol</i>	18:1388–94.	Population
Song	2015	Health- related quality of life from the MM- 003 trial of pomalidomide plus low- dose dexamethasone versus high- dose dexamethasone in relapsed and/or refractory multiple myeloma.	<i>Haematologica</i>	100:e63–7.	Population
Stewart	2015	Carfilzomib, lenalidomide, and dexamethasone for relapsed multiple myeloma.	<i>N Engl J Med</i>	372(2):142–52.	Population
Verelst	2011	Effect of thalidomide with melphalan and prednisone on health- related quality of life (HRQoL) in elderly patients with newly diagnosed multiple myeloma: a prospective analysis in a randomized trial.	<i>Ann Hematol</i>	90:1427–39.	Population
Waage	2010	Melphalan and prednisone plus thalidomide or placebo in elderly patients with multiple myeloma.	<i>Blood</i>	116:1405–12.	Identified and excluded in electronic searches
Waage	2004	Early response predicts thalidomide efficiency in patients with advanced multiple myeloma.	<i>Br J Haematol</i>	125:149–55	Population
Wisloff	1996	Measurement of health- related quality of life in multiple myeloma. Nordic Myeloma Study Group.	<i>Br J Haematol</i>	94:324–32.	Population
Wisloff	1996	Effect of interferon on the health- related quality of life of multiple myeloma patients: results of a Nordic randomized trial comparing melphalan-	<i>Br J Haematol</i>	94:324–32	Intervention

		prednisone to melphalan-prednisone + alpha-interferon. The Nordic Myeloma Study Group.			
--	--	--	--	--	--

^aThis publication reported outcomes with bortezomib maintenance therapy post-ASCT, which is not a licensed therapy for maintenance and is therefore not considered relevant in this setting.

7. Systematic literature review of resource use and cost of care with maintenance with lenalidomide

Four publications were identified that reported costs of care associated with maintenance in ASCT. Upon review, none provide data that could be incorporated in the model to represent the UK base case for post-ASCT maintenance with lenalidomide .

- Ashcroft et al. Chart review across eu5 in mm post-asct patients. 2018. International Journal of Hematologic Oncology.
- Jackson et al. Lenalidomide maintenance therapy post-autologous stem cell transplant: A healthcare cost-impact analysis in Europe. 2017. Blood. Conference: 59th Annual Meeting of the American Society of Hematology, ASH.
- Jackson et al. Productivity losses in patients with newly diagnosed multiple myeloma following stem cell transplantation and the impact of maintenance therapy. 2019. European Journal of Haematology
- Niphadkar et al. Autologous stem cell transplant: A cost effective and efficacious treatment for newly diagnosed multiple myeloma. 2016. Blood. Conference: 58th Annual Meeting of the American Society of Hematology, ASH.

The study by Jackson et al (2017) was reported in a conference abstract and could not be obtained, whilst the publication by Jackson et al (2019) focussed on productivity losses and did not include any information pertinent to medical care costs.

The study by Ashcroft et al (2018) was a retrospective chart review of post-ASCT resource use for 337 patients in Europe. The study included 25 patients who received maintenance, 2 of which were UK-based patients. Of the 59 patients who were included in the study and were UK-based, 12 responded to the survey. The results from UK patients were not reported separately by Country but rather, the tariffs for healthcare services of each Country were used to cost the overall dataset

for the EU5. The study concluded that based on the UK tariff, the current cost of healthcare use for people with maintenance amounts to 638 Euro (SD 548 Euro), approximately 65% of the cost of people who did not receive maintenance (1,002 Euro, SD 1123 Euro). These data were not used in our model since only a very limited number of UK patients were involved and resource use was not reported by Country. We concluded that study estimates for subsequent treatment costs were also not specified by type of therapies available in the UK. We concluded that this paper did not offer representative data for post-ASCT resource consumption for the UK reference case.

The study by Niphadkar et al (2016) is published in abstract only. This was a costing study for ASCT + maintenance in the US and draws on administrative billing data for approximately 45,000 ASCT hospital admissions. In addition, the yearly cost of post-ASCT therapies in the US was also presented. As our cost-effectiveness model does not include the cost of ASCT, and the cost of subsequent therapy was calculated simply as the price of each drug by an assumed duration of therapy (43.4 months) in the US, we concluded that this study did not present data relevant for our model.

Technical engagement response form

Lenalidomide for the maintenance treatment of multiple myeloma after autologous stem cell transplant [ID475]

As a stakeholder you have been invited to comment on the technical report for this appraisal. The technical report and stakeholders responses are used by the appraisal committee to help it make decisions at the appraisal committee meeting. Usually, only unresolved or uncertain key issues will be discussed at the meeting.

We need your comments and feedback on the questions below. You do not have to answer every question. The text boxes will expand as you type. Please read the notes about completing this form. We cannot accept forms that are not filled in correctly. Your comments will be summarised and used by the technical team to amend or update the scientific judgement and rationale in the technical report.

Deadline for comments: 23 July 2020

Thank you for your time.

Please log in to your NICE Docs account to upload your completed form, as a Word document (not a PDF).

Notes on completing this form

- Please see the technical report which summarises the background and submitted evidence. This will provide context and describe the questions below in greater detail.
- Please do not embed documents (such as PDFs or tables) because this may lead to the information being mislaid or make the response unreadable. Please type information directly into the form.
- Do not include medical information about yourself or another person that could identify you or the other person.
- Do not use abbreviations.
- Do not include attachments such as journal articles, letters or leaflets. For copyright reasons, we will have to return forms that have attachments without reading them. You can resubmit your form without attachments, but it must be sent by the deadline.
- If you provide journal articles to support your comments, you must have copyright clearance for these articles.
- Combine all comments from your organisation (if applicable) into 1 response. We cannot accept more than 1 set of comments from each organisation.

- Please underline all confidential information, and separately highlight information that is submitted under **'commercial in confidence' in turquoise**, all information submitted under **'academic in confidence' in yellow**, and all information submitted under **'depersonalised data' in pink**. If confidential information is submitted, please also send a second version of your comments with that information replaced with the following text: 'academic/commercial in confidence information removed'. See the [Guide to the processes of technology appraisal](#) (sections 3.1.23 to 3.1.29) for more information.

We reserve the right to summarise and edit comments received during engagement, or not to publish them at all, if we consider the comments are too long, or publication would be unlawful or otherwise inappropriate.

Comments received during engagement are published in the interests of openness and transparency, and to promote understanding of how recommendations are developed. The comments are published as a record of the comments we received, and are not endorsed by NICE, its officers or advisory committees.

About you

Your name	████████████████████
Organisation name – stakeholder or respondent (if you are responding as an individual rather than a registered stakeholder please leave blank)	Myeloma UK
Disclosure Please disclose any past or current, direct or indirect links to, or funding from, the tobacco industry.	Nil

Questions for engagement

Issue 1: The lenalidomide regimen in the company submission is not aligned with the marketing authorisation	
a) What dosing schedule would be used in clinical practice for maintenance therapy with lenalidomide following ASCT: 1 to 21 days or 1 to 28 days of a 28-day cycle?	The vast majority of UK patients, and those that responded to our survey, would have received lenalidomide maintenance via the Myeloma XI trial which recruited 4,000 patients. The dosing schedule for Myeloma XI is 1 to 21 days of a 28 day cycle and after discussion with clinicians we would expect that this would be the standard. This also reflects how lenalidomide is given in other indications and clinicians therefore have considerable experience of this schedule.
b) Is lenalidomide likely to be as effective and safe over 1 to 21 days as it is over 1 to 28 days of a 28-day cycle?	We are not aware of any trial data that show a direct comparison between the two. We would highlight the strong clinical benefit demonstrated via Myeloma XI and the fact that from our survey 63% of patients on maintenance said that side effects did not impact at all on their ability to complete normal daily activities.
c) If a 1 to 28-day dosing schedule is used a) are the results of the Myeloma XI trial generalisable to clinical practice in the NHS, and b) are there any implications for drug wastage?	Not aware of any relevant data.
d) What proportion of patients are likely to escalate their dose to 15 mg once daily in clinical practice?	Having consulted with clinicians the dose that patients receive is 10mg daily.

Issue 2: The company excluded evidence from potentially relevant clinical trials	
a) Are the CALGB 100104 and GIMEMA trials, which both use the dosing schedule in the marketing authorisation, relevant to the decision problem and should the results be considered by the committee?	Our submission refers to clinically significant findings in these trials and we believe the results are relevant.
b) Is it appropriate to synthesise data from Myeloma XI, CALGB 100104 and GIMEMA (for example, in a network meta-analysis)?	No comment.
c) Should CALGB 100104 and GIMEMA trial data be used in the economic model?	No comment.
Issue 3: The company did not present adverse event data for the observation arm of the target population from Myeloma XI	
a) Is maintenance therapy with lenalidomide likely to have an acceptable safety profile?	Yes. We refer the committee to the results of our survey.
b) Are rates of serious adverse events in the intention-to-treat population of Myeloma XI likely to be generalisable to the decision problem cohort?	No comment.
Issue 4: Concerns with the company's systematic review of economic evidence	
a) Is it appropriate for the company to use alternative sources of costs and resource use rather than those identified by the systematic review?	No comment
b) Is the company's systematic review of economic evidence adequately reported?	No comment
Issue 5: The company's method for estimating subsequent treatment costs may not be appropriate	

<p>a) For people receiving lenalidomide maintenance therapy following ASCT, which therapies are they likely to receive at 2nd, 3rd and subsequent lines (not including therapies available through the cancer drugs fund [CDF])?</p>	<p>We understand the rules governing the exclusion of CDF funded drugs from the Committee's consideration. However, for the record, the treatment used most commonly at second line is likely to be daratumumab, velcade and dexamethasone and at third line ixazomib, lenalidomide and dexamethasone, both of which are funded via the CDF. Non-CDF options include carfilzomib and dexamethasone (for bortezomib naïve patients), panobinostat with velcade and pomalidomide and dexamethasone.</p>
<p>b) For people receiving observation following ASCT, which therapies are they likely to receive at 2nd, 3rd and subsequent lines (not including therapies available through the cancer drugs fund [CDF])?</p>	<p>See above.</p>
<p>c) Are people likely to receive a second ASCT? If so, at what point in the treatment pathway?</p>	<p>Some patients who have responded well to transplant at first line may also receive an HDT-SCT at second line. We are not aware of data specifying the proportion of patients who received second line transplants but we would expect it to be very low.</p>
<p>d) Are the company's or the ERG's assumptions about subsequent treatments most appropriate?</p>	<p>No comment</p>
<p>Issue 6: The company provided highly uncertain estimates of overall survival, and the company and ERG disagree on which distribution to use for extrapolation</p>	
<p>a) Should a joint model or independent models be used to extrapolate OS?</p>	<p>No comment</p>
<p>b) If independent models are chosen, is a log-logistic model appropriate for extrapolation of the lenalidomide maintenance arm and a</p>	<p>No comment</p>

Weibull model appropriate for extrapolation of the observation arm?	
c) How many patients are expected to be alive at 10 years in the lenalidomide arm? Is [REDACTED] a reasonable estimate?	No comment
d) Is the company's ([REDACTED]) or the ERG's ([REDACTED]) estimate of the number of people alive after 10 years in the observation arm most appropriate?	We are not able to answer this question directly. However, we believe the figure is likely to be higher than 20 per cent.
e) Is it appropriate to use CALGB 100104 data to inform OS curve model selection? If so, was the company correct to choose the rank preserving structural failure time (RPSFT) method to adjust for treatment switching in CALGB 100104, and why?	No comment.
f) Is there likely to be a waning of treatment effect with lenalidomide maintenance therapy? Or is the company's assumption of [REDACTED] more realistic?	No comment.
Issue 7: Uncertain impact of dose adjustments and wastage on drug costs	
a) In clinical practice, what is the likely relative dose intensity (RDI) of lenalidomide maintenance, i.e. the estimated percentage of doses actually delivered out of those that are planned?	No comment.
b) What are likely to be the main reasons to deviate from the recommended dosing of 10	We assume this will be due to toxicity issues.

mg per day on days 1 to 21 of a 28-day cycle (e.g. dose reduction, missed doses, etc.)?	
c) Should the RDI from the Myeloma XI trial (■) or TMM1 trial (95%) be used in the economic model?	No comment
d) Are wastage costs appropriately accounted for?	No comment
Issue 8: Whether medical resource use should differ between treatments and between relapse status	
a) Is medical resource use likely to be the same between maintenance therapy with lenalidomide and observation? If not, how do they vary?	Given that by definition observation is likely to mean minimal intervention and medical resource, we would expect patients on the maintenance arm to have more blood tests and checks to review for side effects.
b) Is medical resource use likely to be the same in the pre-progression and post-progression states? If not, how do they vary?	No comment.
c) Are the company's or ERG's estimates of medical resource use costs the most appropriate?	No comment

Technical engagement response form

Lenalidomide for the maintenance treatment of multiple myeloma after autologous stem cell transplant [ID475]

As a stakeholder you have been invited to comment on the technical report for this appraisal. The technical report and stakeholders responses are used by the appraisal committee to help it make decisions at the appraisal committee meeting. Usually, only unresolved or uncertain key issues will be discussed at the meeting.

We need your comments and feedback on the questions below. You do not have to answer every question. The text boxes will expand as you type. Please read the notes about completing this form. We cannot accept forms that are not filled in correctly. Your comments will be summarised and used by the technical team to amend or update the scientific judgement and rationale in the technical report.

Deadline for comments: **16th July 2020**

Thank you for your time.

Please log in to your NICE Docs account to upload your completed form, as a Word document (not a PDF).

Notes on completing this form

- Please see the technical report which summarises the background and submitted evidence. This will provide context and describe the questions below in greater detail.
- Please do not embed documents (such as PDFs or tables) because this may lead to the information being mislaid or make the response unreadable. Please type information directly into the form.
- Do not include medical information about yourself or another person that could identify you or the other person.
- Do not use abbreviations.
- Do not include attachments such as journal articles, letters or leaflets. For copyright reasons, we will have to return forms that have attachments without reading them. You can resubmit your form without attachments, but it must be sent by the deadline.
- If you provide journal articles to support your comments, you must have copyright clearance for these articles.
- Combine all comments from your organisation (if applicable) into 1 response. We cannot accept more than 1 set of comments from each organisation.

- Please underline all confidential information, and separately highlight information that is submitted under 'commercial in confidence' in turquoise, all information submitted under 'academic in confidence' in yellow, and all information submitted under 'depersonalised data' in pink. If confidential information is submitted, please also send a second version of your comments with that information replaced with the following text: 'academic/commercial in confidence information removed'. See the [Guide to the processes of technology appraisal](#) (sections 3.1.23 to 3.1.29) for more information.

We reserve the right to summarise and edit comments received during engagement, or not to publish them at all, if we consider the comments are too long, or publication would be unlawful or otherwise inappropriate.

Comments received during engagement are published in the interests of openness and transparency, and to promote understanding of how recommendations are developed. The comments are published as a record of the comments we received, and are not endorsed by NICE, its officers or advisory committees.

About you

Your name	████████████████████
Organisation name – stakeholder or respondent (if you are responding as an individual rather than a registered stakeholder please leave blank)	Royal College of Pathologists/British Society of Haematology
Disclosure Please disclose any past or current, direct or indirect links to, or funding from, the tobacco industry.	None

Questions for engagement

Issue 1: The lenalidomide regimen in the company submission is not aligned with the marketing authorisation	
a) What dosing schedule would be used in clinical practice for maintenance therapy with lenalidomide following ASCT: 1 to 21 days or 1 to 28 days of a 28-day cycle?	1 to 21 days of a 28 day cycle would be standard in the UK. This is based on the Myeloma XI trial in the UK that recruited 4000 patients. It should be noted that for indications other than maintenance, lenalidomide is given as a 1 to 21 day of a 28 day cycle so that UK Haematologists have developed experience with this schedule in the treatment of patients with myeloma
b) Is lenalidomide likely to be as effective and safe over 1 to 21 days as it is over 1 to 28 days of a 28-day cycle?	No data available to answer this. There are issues with cross trial comparisons and interpretations of differences in PFS/OS data. It is impossible to know the answer to this with any certainty
c) If a 1 to 28-day dosing schedule is used a) are the results of the Myeloma XI trial generalisable to clinical practice in the NHS, and b) are there any implications for drug wastage?	No data available to answer this
d) What proportion of patients are likely to escalate their dose to 15 mg once daily in clinical practice?	The dose of maintenance is 10mg daily. Unclear why the dose would be increased to 15 mg at all
Issue 2: The company excluded evidence from potentially relevant clinical trials	
a) Are the CALGB 100104 and GIMEMA trials, which both use the dosing schedule in the marketing authorisation, relevant to the	Yes they are clearly relevant. They inform as to benefit and toxicity of lenalidomide maintenance in other large phase III studies. There are always issues with direct

decision problem and should the results be considered by the committee?	comparisons given the differences between trials but similar benefits in PFS and OS would support the Myeloma XI results.
b) Is it appropriate to synthesise data from Myeloma XI, CALGB 100104 and GIMEMA (for example, in a network meta-analysis)?	Yes
c) Should CALGB 100104 and GIMEMA trial data be used in the economic model?	Yes
Issue 3: The company did not present adverse event data for the observation arm of the target population from Myeloma XI	
a) Is maintenance therapy with lenalidomide likely to have an acceptable safety profile?	Yes it does. Extensive experience in the four trials
b) Are rates of serious adverse events in the intention-to-treat population of Myeloma XI likely to be generalisable to the decision problem cohort?	Yes
Issue 4: Concerns with the company's systematic review of economic evidence	
a) Is it appropriate for the company to use alternative sources of costs and resource use rather than those identified by the systematic review?	
b) Is the company's systematic review of economic evidence adequately reported?	
Issue 5: The company's method for estimating subsequent treatment costs may not be appropriate	
a) For people receiving lenalidomide maintenance therapy following ASCT, which therapies are they likely to receive at 2 nd , 3 rd and subsequent lines (not including therapies	They are likely to receive therapies available on the CDF now (Daratumumab-Velcade-Dex as second line) so answering this question is difficult. Options outside

<p>available through the cancer drugs fund [CDF])?</p>	<p>of CDF are extremely limited Velcade-Panobinostat as 3rd line and 4th line pomalidomide (single agent daratumumab in reality but on CDF)</p>
<p>b) For people receiving observation following ASCT, which therapies are they likely to receive at 2nd, 3rd and subsequent lines (not including therapies available through the cancer drugs fund [CDF])?</p>	<p>They are likely to receive therapies available on the CDF now (Daratumumab-Velcade-Dex as second line and ixazomib+lenalidomide+dexamethasone as third line) so answering this question is difficult. Options outside of CDF are extremely limited -lenalidomide as second line, Velcade-Panobinostat as 3rd line and 4th line pomalidomide (single agent daratumumab in reality but on CDF)</p>
<p>c) Are people likely to receive a second ASCT? If so, at what point in the treatment pathway?</p>	<p>It would be sensible to look at the data from the trial (or other sources if available) to answer this. I believe the data suggests that <5% received a second transplant</p>
<p>d) Are the company's or the ERG's assumptions about subsequent treatments most appropriate?</p>	
<p>Issue 6: The company provided highly uncertain estimates of overall survival, and the company and ERG disagree on which distribution to use for extrapolation</p>	
<p>a) Should a joint model or independent models be used to extrapolate OS?</p>	
<p>b) If independent models are chosen, is a log-logistic model appropriate for extrapolation of the lenalidomide maintenance arm and a Weibull model appropriate for extrapolation of the observation arm?</p>	

<p>c) How many patients are expected to be alive at 10 years in the lenalidomide arm? Is [redacted] a reasonable estimate?</p>	<p>This estimate is high and I feel is inaccurate.</p>
<p>d) Is the company's ([redacted]) or the ERG's ([redacted]) estimate of the number of people alive after 10 years in the observation arm most appropriate?</p>	<p>20% would be an underestimate as these are transplant eligible patients and their 10 year survival rates are better than transplant ineligible patients</p>
<p>e) Is it appropriate to use CALGB 100104 data to inform OS curve model selection? If so, was the company correct to choose the rank preserving structural failure time (RPSFT) method to adjust for treatment switching in CALGB 100104, and why?</p>	<p>Not qualified to comment</p>
<p>f) Is there likely to be a waning of treatment effect with lenalidomide maintenance therapy? Or is the company's assumption of [redacted]</p> <p>g) [redacted] more realistic?</p>	<p>Yes improving responses over time is well recognised with deepening responses. But usually these responses are seen within the first year after transplant</p>
<p>Issue 7: Uncertain impact of dose adjustments and wastage on drug costs</p>	
<p>a) In clinical practice, what is the likely relative dose intensity (RDI) of lenalidomide maintenance, i.e. the estimated percentage of doses actually delivered out of those that are planned?</p>	<p>There are no data available to base these estimates on</p>
<p>b) What are likely to be the main reasons to deviate from the recommended dosing of 10 mg per day on days 1 to 21 of a 28-day cycle (e.g. dose reduction, missed doses, etc.)?</p>	<p>A small percentage of patients would dose reduce for toxicity. This information should be available in the Myeloma XI trial</p>

c) Should the RDI from the Myeloma XI trial (■) or TMM1 trial (95%) be used in the economic model?	Myeloma XI trial is more appropriate for UK population
d) Are wastage costs appropriately accounted for?	
Issue 8: Whether medical resource use should differ between treatments and between relapse status	
a) Is medical resource use likely to be the same between maintenance therapy with lenalidomide and observation? If not, how do they vary?	Lenalidomide therapy patients will have more frequent blood tests, frequent consultations and review for adverse events. However patients in the control arm progress sooner and would need more frequent monitoring following progression and earlier second line treatment
b) Is medical resource use likely to be the same in the pre-progression and post-progression states? If not, how do they vary?	They would vary as pre progression the visits are likely to be 4 weekly for lenalidomide arm and about 8 weekly for observation arm, post progression medical resource use is dictated by the treatment patients are on
c) Are the company's or ERG's estimates of medical resource use costs the most appropriate?	

Lenalidomide for the maintenance treatment of multiple myeloma after autologous stem cell transplant [ID475]

A Single Technology Appraisal

ERG Review of Company's Response to Technical Engagement

Produced by

**Peninsula Technology Assessment Group (PenTAG)
University of Exeter Medical School
South Cloisters
St Luke's Campus
Heavitree Road
Exeter
EX1 2LU**

Authors

**Caroline Farmer¹
Emma Knowles²
Helen Coelho¹
Justin Matthews¹
Sophie Robinson¹
Naomi Shaw¹
Claudius Rudin³
Jenny Bird⁴
Simone Critchlow²
Louise Crathorne¹
G.J. Melendez-Torres¹**

¹ Peninsula Technology Assessment Group (PenTAG), University of Exeter Medical School, Exeter

² Delta Hat Ltd, Nottingham UK

³ Dorset County Hospital, UK

Correspondence to	⁴ University Hospitals Bristol NHS Foundation Trust, UK Caroline Farmer 3.09 South Cloisters, St Luke's Campus, Heavitree Road, Exeter, EX1 2LU; C.Farmer@exeter.ac.uk
Source of funding	This report was commissioned by the NIHR Systematic Reviews Programme as project number 17/46/12
Declared competing interests of the authors	The authors listed declared no competing interests.
Rider on responsibility for document	The views expressed in this report are those of the authors and not necessarily those of the NIHR HTA Programme. Any errors are the responsibility of the authors.
This TE response is linked to ERG report	Farmer, Knowles, Coelho, Matthews, Robinson, Shaw, Critchlow, Rudin, Bird, Crathorne, Melendez-Torres. Lenalidomide for the maintenance treatment of multiple myeloma after autologous stem cell transplant [ID475]. Peninsula Technology Assessment Group (PenTAG), 2020.
Copyright	© 2020, PenTAG, University of Exeter. Copyright is retained by Celgene for tables and figures copied and/or adapted from the company submission and other submitted company documents.

1. INTRODUCTION

This document provides the Evidence Review Group's (ERG's) critique of the company's response to the technical engagement report produced by the National Institute for Health and Care Excellence (NICE) for the appraisal of 'Lenalidomide for the maintenance treatment of newly diagnosed multiple myeloma after autologous stem cell transplantation' [ID475]. Each of the issues outlined in the technical report are discussed in further detail in Section 3.

The company has made a number of changes to their economic model. In their review, the ERG identified a number of errors in the implementation of the company revised model. The ERG corrected these errors and have presented amended results for the company revised base case. However, in the time available, the ERG have not amended the results of the company's revised sensitivity analyses. Furthermore, the ERG were not able to perform a comprehensive review of the company revised model, and therefore it is possible that not all errors were identified and corrected. The ERG's critique of the company revised model is presented in Section 2.

The ERG have not made any changes to their original preferred base case following the company's response to technical engagement.

2. UPDATED COMPANY ALTERNATIVE ERG BASE CASE ANALYSES

In response to the technical engagement (TE) report, the company have revised their economic model following updates to the survival analysis, subsequent therapy distributions, and estimates of relative dose intensity (RDI) and wastage. In addition, the company accepted several of the ERG's preferred base case assumptions, however some assumptions were not applied correctly within the model.

In addition, several other errors were found within the updated economic model leading the ERG to question the validity of the new analysis. These errors include hardcoding for two subsequent therapy distributions and the application of a

[REDACTED]

The revisions made by the company are discussed further below (Sections 2.1 – 2.4).

2.1. Survival analysis

In the company's response to TE, a new analysis of survival data was conducted on pooled data from the Myeloma XI and CALGB 100104^{1,2} studies. The ERG did not request this revision to the analyses and do not believe the pooled approach to be appropriate.

During the TE call (24/06/20), the company indicated their intention to pool the data from Myeloma XI and CALGB 100104 and extrapolate overall survival (OS) and progression-free survival (PFS) using joint parametric models. The revised model submitted alongside the company's TE response therefore incorporated the pooled analyses, which now inform the company revised base case. **Error! Reference source not found.** reports the parametric models selected in the company original base case, the ERG preferred base case, and the company revised base case for OS and PFS.

Table 1: Submitted base case assumptions for survival extrapolation

	Component	Company original base case	ERG preferred base case	Company revised base case
OS	Data	MXI	MXI	MXI & CALGB
	Independent/dependent	Independent	Dependent	Dependent
	Curve fit Len	Log-logistic	Log-logistic	Weibull

	Component	Company original base case	ERG preferred base case	Company revised base case
	Curve fit Observation	Weibull		
PFS	Data	MXI	MXI	MXI & CALGB
	Independent/dependent	Dependent	Dependent	Dependent
	Curve fit Len	Exponential	Weibull	Generalised gamma

Abbreviations: CALGB, Cancer and Leukemia Group B; ERG, Evidence Review Group; MXI, Myeloma XI; OS, overall survival; PFS, progression free survival

The ERG have previously outlined the limitations in comparing the CALGB 100104 data with Myeloma XI, which consist of (but are not limited to), the fundamental differences between the trial populations, different dosing regimens, and the need for statistical methodology to account for treatment switching within CALGB 100104. Further information relating to limitations in the comparability of the two trials can be found in Issue 6e (Section 3.6) of this document and Section 4.2.6.1. of the ERG report.

Issues relating to the generalisability of these two trials (i.e. the differences in the patients within these trials and the corresponding trial protocols), mean that pooling of this data only introduces further uncertainty into OS and PFS estimates used to inform the economic model. The ERG does not consider the company to have provided sufficient justification for pooling data, and prefers the use of the Myeloma XI data only on which to base the selection of survival extrapolation curves. Nevertheless, the ERG has provided a brief critique of the company's model selection to the pooled data and provided comparison to prior preferred base case settings.

2.1.1. Overall survival

The company selected a joint Weibull model to predict OS for lenalidomide using extrapolations from the pooled data for Myeloma XI and CALGB 100104^{1,2} (with covariates for treatment and study).

The ERG notes that in Figure 5 of the company's response to TE addendum (p.6), the OS extrapolations for the Weibull, log-logistic and generalised gamma models all very similarly fit the Myeloma XI Kaplan-Meier (KM) curves for lenalidomide maintenance and observation until approximately 5 years. After this point, the curves separate dramatically, with the log-logistic model seemingly providing the best visual fit to the lenalidomide maintenance CALGB 100104 KM, and the Weibull to the observation CALGB 100104 KM.

*****1** below combines the company original base case, the company revised base case, and the ERG base case to provide an illustration of how the OS of lenalidomide maintenance and observation have been projected. All curves provide a reasonable visual fit to the KM for the observed period. As illustrated, the company revised base case is similar to their original base case and the ERG's preferred OS extrapolation for lenalidomide in the short run (~10 years). Beyond this, the new extrapolation is markedly different from prior predictions.



Abbreviations: Len; lenalidomide, SoC; standard of care

2.1.2. Progression-free survival

The company selected a joint generalised gamma model to extrapolate PFS for the Myeloma XI patients using the pooled data for Myeloma XI and CALGB 100104^{1,2} (with covariates for treatment and study).

The ERG notes that the extrapolated curves for PFS fit both the Myeloma XI and CALGB 100104 data reasonably well visually, as seen in Figure 6 of the company's response to TE addendum (p.7). The ERG believes selecting the dependent Weibull model for the Myeloma XI data solely (the ERGs preferred base case) provides a better visual fit to the KM data.

***2 below combines the original company base case, the company revised base case, and the ERG base case to provide an illustration of how the PFS of lenalidomide maintenance and observation have been projected.

2

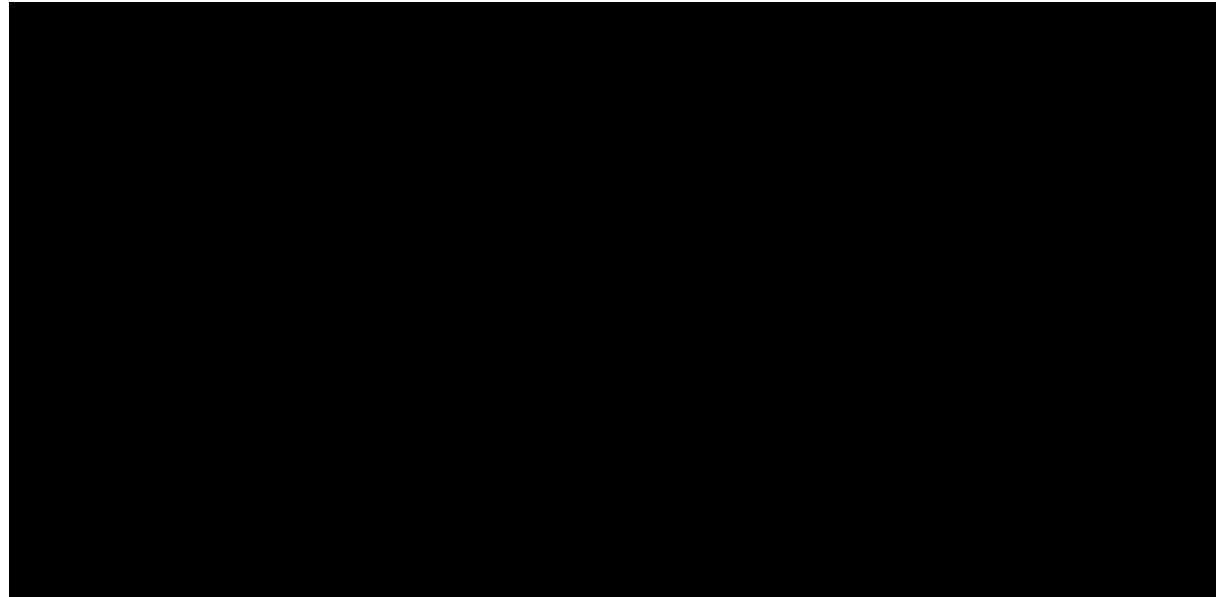

Abbreviations: Len; lenalidomide, SoC; standard of care

2.2. Subsequent therapy distribution

In the company's response to TE they provided updated subsequent therapy distributions to be used for analysis (further details provided in Issue 5, Section 3.5). However, the ERG notes that the revised proportions are subject to the following issues:

- Use of lenalidomide in the 2nd line is not currently reimbursed by NICE (note: this is also a limitation of the ERG's preferred assumptions as the issues regarding 2nd line use of lenalidomide were only raised by the company at factual accuracy check (FAC) stage)
- Use of carfilzomib at the 2nd line is highly unlikely as it is not reimbursed by NICE following treatment with bortezomib (which in current practice would be administered as induction for ASCT)

- Differences in the proportion of patients set to receive 'no treatment' at the 3rd line between arms (■ for lenalidomide maintenance versus ■ for observation).

As noted in their report, the ERG considers that due to the need to omit CDF therapies from the analysis, the distribution of subsequent treatments which may be used at the 2nd and 3rd line may not reflect the options used in NHS practice. Clinical advice provided to the ERG, noting that CDF therapies address a lack of options, highlighted that to predict the treatment pathway with these treatments removed creates unavoidable uncertainty in the treatment pathway following relapse.

In the absence of any new information / data available to revise estimates, the ERG has chosen not to revise their base case assumptions relating to subsequent therapies. The ERG acknowledges the ICER is highly influenced by the assumptions regarding subsequent therapies, and believes that the subject requires further discussion at the committee meeting.

2.3. RDI and wastage

The company provided a new relative dose intensity (RDI) estimate, calculated from Myeloma XI data, which has been incorporated into their revised base case. There is an increase in the expected RDI from the original estimate: in the original CS, RDI from Myeloma XI was reported to be ■, whereas the revised RDI is ■. The company state that the revised estimate has been calculated to account for: (i) non-linear pricing between 10mg and 5mg dosing; (ii) treatment-free intervals; and (iii) drug wastage.

Information provided by the company in response to TE indicate that the Myeloma XI trial did not directly measure the prescribed versus the actual dose received by patients, including a reliable estimate of wastage. This, combined with different approaches to measuring dose (between v5 and v6 of the trial protocol) means that in order to address concerns raised in the ERG report, the company have had to make a series of calculations and underlying assumptions. Where assumptions were clear, the ERG believed these to be reasonable; however not all assumptions were transparent or listed, and the overall methodology of estimating the revised RDI estimate was difficult to follow without additional information. The ERG considered that the methodological approach was not transparent enough to be validated, and therefore did not consider it appropriate to change any ERG base case settings. The ERG did explore the impact of implementing the revised estimate into the ERG base case. This resulted in a change from ■ (ERG base case settings) to ■ (ERG base case settings)

but with an RDI of [REDACTED] instead of [REDACTED]). The ERG considers the model results to be sensitive to RDI assumptions.

2.4. Company application of ERG assumptions

The company revised economic model has been adapted from the version submitted to NICE following clarification stage and not the ERG version, resulting in the incorrect application of some accepted ERG assumptions. Consequently, the ERG base case results cannot be obtained within the company revised economic model without first fixing these inaccurate applications. The following ERG assumptions were accepted by the company:

- Setting the cost of “other” treatments equal to the CTD regimen
- Setting the cost of bortezomib to the eMIT price
- Setting MRU costs post-relapse equal to pre-relapse halving pre-relapse outpatient visits for observation

Table 2 presents the accepted ERG assumptions and issues with the company’s application within the economic model.

Table 2: Application of ERG assumptions within the company's revised economic model

ERG preferred assumption	Application within the company’s revised economic model	Revised application in company’s TE response model
Set the cost of “other” treatment equal to CTD regimen	The company have not implemented this change in the economic model. The total regimen cost of “other” treatment remains at £5,485 as in the previous company model. The total regimen cost per the ERG’s assumption is £7,119.	Cell changes - Cost data, D95
Use eMIT as the source cost for bortezomib	Previously the company used the list price of £762 per 3.5mg vial and applied an [REDACTED] to cost bortezomib. The company now incorporate the eMIT price of £162 per 1mg vial for bortezomib however, [REDACTED] has not been removed. Furthermore, in the ERG base case, the eMIT price of £526 per 3.5 mg vial was applied compared to £162 per 1 mg vial. This discrepancy between models is small however, results in a slightly higher cost per cycle applied to the company’s analysis compared to the ERG’s.	Remove [REDACTED] PAS, cell changes – Cost data, J35 Use 3.5mg eMIT price, cell changes – Cost data, C35, H35
Halve outpatient visits pre-relapse	The company have not implemented this change correctly in the model.	Set post-progression MRU equal to pre-

ERG preferred assumption	Application within the company's revised economic model	Revised application in company's TE response model
for the observation arm and set MRU costs post-relapse equal to observation MRU pre-relapse.	<p>The company has halved the frequency of all MRU for the pre-progression observation arm, rather than halving outpatient visits only.</p> <p>The company has not correctly set the post-relapse MRU costs equal to the MRU cost for pre-progression observation. In addition, as a consequence of halving all MRU in the observation arm, the resulting post-progression cost is incorrect. Further details are provided in Issue 8.</p>	<p>progression observation MRU, cell changes – Cost data, Cost data J208</p> <p>Halve outpatient visits for observation pre-progression, cell changes – Cost data, I211</p>

Abbreviations: CTD, cyclophosphamide, thalidomide and dexamethasone; eMIT, electronic market information tool; ERG, Evidence Review Group; MRU, medical resource use; PAS, patient access scheme.

Furthermore, when the subsequent therapy source is set to “ERG”, the proportions assigned to lenalidomide maintenance post 1st relapse for a second ASCT and ‘other’ treatment do not align with the ERG base case due to hardcoding within the model cells. The ERG’s preferred settings are 15% and 20% for a second ASCT and ‘other’ treatment respectively, compared to ■ and ■ applied within the company revised model.

2.5. Company's base case results

The company's revised base case results are presented in the company response to TE addendum Table 7 (p.22) and replicated in Table 3 below.

Table 3: Company's revised base case results

Arm	Total			Incremental			ICER (£/QALY)
	Costs (£)	LYs	QALYs	Costs (£)	LYs	QALYs	
Company revised base case (deterministic)							
Observation	■	■	■				
Lenalidomide	■	■	■	■	■	■	■

Abbreviations: ICER, incremental cost-effectiveness ratio; LY, life year; QALY, quality adjusted life year.

The company reported a base case ICER of ■ for lenalidomide maintenance versus observation. However, the ERG notes that this analysis is subject to multiple errors (detailed in Section 2.4) and does not reflect agreed discounts that are available to the NHS for all included treatments, including the inaccurate PAS discount for lenalidomide 5 mg.

Given the incorrect application of settings listed above (see Table 2), the ERG has provided a corrected estimate of the company revised base case, incorporating the following changes: set

the cost of ‘other’ treatment to CTD regimen; halve outpatient appointments for the pre-progression observation arm; set post-progression MRU equal to pre-progression observation MRU; remove bortezomib assumed PAS; cost bortezomib using the eMIT 3.5 mg vial price; and set lenalidomide 5mg PAS to [REDACTED] after loss of exclusivity date. Results are provided in Table 4 below. The ERG notes that a full check of all model calculations has not been performed in the company revised model as the company chose not to conduct their changes within the ERG version. Therefore, the ERG cannot be certain that no other errors were introduced in the revised analysis.

Table 4: ERG representation of company revised base case results

Arm	Total			Incremental			ICER (£/QALY)
	Costs (£)	LYs	QALYs	Costs (£)	LYs	QALYs	
<i>ERG representation of company revised base case (deterministic)</i>							
Observation	[REDACTED]	[REDACTED]	[REDACTED]				
Lenalidomide	[REDACTED]	[REDACTED]	[REDACTED]	[REDACTED]	[REDACTED]	[REDACTED]	[REDACTED]

Abbreviations: ICER, incremental cost-effectiveness ratio; LY, life year; QALY, quality adjusted life year.

2.5.1. Sensitivity analysis

The company provided an updated sensitivity analysis within its response to TE addendum. The revised probabilistic sensitivity analysis (PSA) found that the probability that lenalidomide was cost-effective at thresholds of £30,000 and £20,000 per QALY gained was [REDACTED] and [REDACTED] respectively. The one-way sensitivity analysis (OWSA) was influenced most by the distribution of subsequent treatments at the 2nd and 3rd lines, and the RDI of lenalidomide maintenance 10mg.

The use of the Myeloma XI data was assessed within a scenario analysis and resulted in [REDACTED] with the pooled data.

The ERG report noted several issues with the originally submitted sensitivity analysis that have not been addressed within the revised analysis. These issues are outlined further in the ERG report Section 5.2 and summarised briefly below:

- The appropriateness of including the distribution of subsequent therapies in the OWSA
- Discrepancies between stated distributions used to vary parameters and actual distributions used

- In some cases, parameters were not distributed at all and therefore not varied within the sensitivity analysis (e.g. MRU costs and rates not varied in the PSA)
- Functionality to include administration costs for oral therapies as a scenario analysis has been disabled
- Limited scenario analyses – none of which explore the impact of survival extrapolation assumptions

The ERG notes that the results of the sensitivity analyses reported by the company are confounded by the errors found by the ERG, which the ERG have been unable to correct within the time available. Moreover, the results of PSA, OWSA and scenario analysis are subject to the errors outlined in Section 2.4. Finally, as noted previously, the ERG were unable to conduct a further check of model calculations, therefore, the ERG cannot be certain that no other errors exist within the revised model.

2.6. ERG preferred assumptions

The further information provided by the company during TE has not changed the ERG's preferred base case assumptions. The ERG's preferred model settings and assumptions are presented again in Table 5, below. The cumulative impact of each setting on the estimated ICER is presented alongside each change. The ERG implemented its changes within the company revised economic model.

Table 5: ERG's preferred model assumptions (company PAS settings)

Preferred assumption	Section in ERG report or response to TE	Cumulative ICER £/QALY
Company revised base case	<i>Response to TE: Section 2.5</i>	████
Set clinical data source to Myeloma XI	<i>Response to TE: Section 2.1</i>	████
Set OS curve to joint log-logistic	<i>Report: Section 4.2.6.1</i>	████
Set PFS curve to joint Weibull	<i>Report Section 4.2.6.2</i>	████
Set RDI for lenalidomide maintenance to 94.9%	<i>Report Section 4.2.8.1</i>	████
Set MRU costs post-relapse same as pre-relapse observation	<i>Section 4.2.8.2</i>	████
Halve pre-relapse outpatient visits for observation*	<i>Report Section 4.2.8.2</i>	████
ERG's preferred subsequent treatment settings	<i>Report Section 4.2.8.4</i>	████
Set cost of "other" equivalent to CTD regimen*	<i>Report Section 4.2.8.4</i>	████
Remove assumed 15% PAS applied to bortezomib*	<i>Response to TE: Section 2.4</i>	████

Set cost of bortezomib from eMIT 3.5mg vial*	Report Section 4.2.8.4	████
--	------------------------	------

*Assumptions previously accepted by the company but require correct implementation within the economic model.

Abbreviations: CTD, cyclophosphamide + thalidomide + dexamethasone; eMIT, electronic market information tool; ERG, Evidence Review Group; ICER, incremental cost-effectiveness ratio; MRU, medical resource use; OS, overall survival; PFS, progression-free survival; QALY, quality adjusted life year; RDI, relative dose intensity.

A comparison of the results for the company revised base case, ERG preferred analysis, and the ERG’s correction of the company revised base case (corrected errors outlined in Section 2.4) are presented in Table 6.

Table 6: Comparison of base case results

Arm	Total			Incremental			ICER (£/QALY)
	Costs (£)	LYs	QALYs	Costs (£)	LYs	QALYs	
Company revised base case (deterministic)							
Observation	████	██	██				
Lenalidomide	████	██	██	████	██	██	████
ERG base case (deterministic)							
Observation	████	██	██				
Lenalidomide	████	██	██	████	██	██	████
ERG representation of company revised base case (deterministic)							
Observation	████	██	██				
Lenalidomide	████	██	██	████	██	██	████

Abbreviations: ICER, incremental cost-effectiveness ratio; LY, life year; QALY, quality adjusted life year.

2.6.1. Sensitivity analysis

The ERG performed an additional scenario analysis where the company’s new RDI estimate was inputted to the ERG’s base case. This resulted in a change in the ICER from ██████████, further details are provided in Section 2.3 and 3.7 (Issue 7) of this document.

Additional ICERs were produced to show the effect of the correct application of the ERG’s assumptions, which were accepted by the company in their response to TE. The ICERs corresponding to the correct application of all assumptions are presented in Section 2.5 and 2.6. The ICER when rectifying the errors in MRU assumptions in isolation of other errors is reported in Section 3.8 (Issue 8).

3. ERG REVIEW OF KEY ISSUES

3.1. Issue 1: The lenalidomide regimen in the company submission is not aligned with the marketing authorisation

In their response to TE, the company repeat existing clinical opinion that a dosing schedule of 1 to 21 days is appropriate for the administration of lenalidomide in clinical practice; cite evidence from CALGB 100104^{1,2} and Myeloma XI to suggest that the benefit of lenalidomide maintenance is similar between dosing regimens in respect of PFS and, less conclusively, for OS; and note that no patients in Myeloma XI escalated to 15 mg.

The ERG regard that the evidence provided concurs with the previous ERG opinion that a dosing schedule of 1 to 21 days is consistent with clinical practice. The ERG acknowledge as well that the evidence provided suggests similarity of effect between both dosing schedules.

The company responded to a sub issue relating to the impact of the dosing schedule on wastage. The company provided additional evidence in this regard in the addendum, which is considered elsewhere in the ERG's discussion of relative dose intensity (RDI; Sections 2.3 and 3.7).

3.2. Issue 2: The company excluded evidence from potentially relevant clinical trials

a) Are the CALGB 100104 and GIMEMA trials, which both use the dosing schedule in the marketing authorisation, relevant to the decision problem and should the results be considered by the committee?

GIMEMA

In their response to TE, the company repeat their argument presented during the factual accuracy check (FAC) for excluding GIMEMA³ from their evidence base. The ERG maintain that evidence from the GIMEMA study should have been included in the company submission, as the study (a) meets the inclusion criteria specified by the company for the systematic literature review (SLR) of the clinical evidence for lenalidomide, and (b) is not inconsistent with the potential care pathway for lenalidomide in this population. The ERG acknowledge that the publication³ is unclear about the methods used in the GIMEMA trial and the relevant analysis, and that this has contributed to the disagreement between the company and the ERG. Following the company's TE response, the ERG identified further estimates for OS and PFS for the GIMEMA trial reported in McCarthy et al. (2017)⁴. This paper is a meta-analysis of the

CALGB 100104, GIMEMA, and IFM trials where the authors had access to patient-level data. The publication reports data specifically for patients who were *known* to have received ASCT in the GIMEMA trial, with figures close to those calculated by the ERG from the original³ publication (HRs of 0.72 (95%CI 0.37 to 1.38) for OS and 0.50 (95%CI 0.31 to 0.80) for PFS). While the company cite the McCarthy et al.⁴ publication in their original submission, it is possible that the company missed this detail, which was presented in supplementary material. The ERG consider that these data resolve the uncertainty about the relevance of data in the GIMEMA trial, and the evidence should have been included in the CS.

Broadly speaking, in cases where data that are potentially relevant to the decision problem are identified, though with some uncertainty about their relevance that (as in this case) the company cannot decisively resolve, the ERG would prefer the data to be included in the CS for scrutiny by the ERG and the committee.

With regards to whether the evidence from GIMEMA should be considered by the committee however, as the ERG noted in their appraisal, data from the GIMEMA trial is associated with several limitations that limit its generalisability to the decision problem. The outcome data identified is broadly supportive of the effectiveness of lenalidomide maintenance therapy in the target population, but the ERG consider the GIMEMA data to have limited importance for the committee's decision-making.

CALGB 100104

The company excluded the CALGB 100104 trial^{1,2} from their systematic literature review (SLR) of clinical evidence in the CS, however in their TE response the company have presented pooled evidence from the CALGB 100104 and Myeloma XI trials, and have used this evidence to inform their revised base case. The company have not provided an explanation for this change in position, and have not provided any additional clinical evidence than was identified by the ERG. The ERG maintain that the CALGB 100104 trial should have been included in the CS, as it met the inclusion criteria for the company's own SLR, and because it is used by the company to inform their original base case. However, the ERG consider that the CALGB 100104 trial is associated with a number of limitations that hinder its generalisability to the decision problem. While the data from CALGB 100104 is generally supportive of the clinical effectiveness of lenalidomide maintenance therapy in this population, the ERG do not consider the trial data to be able to reduce uncertainty in outcome estimates.

b) Is it appropriate to synthesise data from Myeloma XI, CALGB 100104 and GIMEMA (for example, in a network meta-analysis)?

In their response to TE, the company present evidence from a pooled analysis with data from Myeloma XI and CALGB 100104^{1,2}. While the ERG argued in their report that clinical evidence from both the CALGB 100104 and GIMEMA³ trials should have been included in the CS for scrutiny by the ERG and the committee (p. 33, 35), the ERG considered the three studies to be too heterogeneous to pool. The ERG further note that in the CS (section 2.8.1.), the company highlight “*transitivity issues between CALGB 100104, GIMEMA, and Myeloma XI*” trials, which “*mean that any meta-analysis between these trials would be subject to a high degree of heterogeneity, particularly with respect to OS*” (CS document B, p.51). During the teleconference with the company and NICE representatives during TE (date 24/06/20) the ERG explicitly advised against pooling the data from Myeloma XI and CALGB 100104. The ERG do not consider the company to have provided sufficient justification for pooling, and the ERG continue to be concerned that differences in design between the CALGB 100104 and Myeloma XI trials preclude pooling (for further information see the ERG report p. 60-61).

c) Should CALGB 100104 and GIMEMA trial data be used in the economic model?

In their response to TE, the company have used pooled data from the CALGB 100104^{1,2} and Myeloma XI trials to inform their revised base case. As described above, the ERG maintains that data from the two trials should not be pooled as the trials are too heterogeneous. Moreover, the ERG do not consider the CALGB 100104 to be applicable to the UK population (ERG report p. 60-61).

One of the differences between the trials identified by the ERG in their report was a difference in Revised International Staging System (ISS) scores at baseline. In their response to TE (addendum, p.1), the company present alternative ISS scores for the CALGB trial, which are more consistent with patients in the Myeloma XI trial. However, the ERG could not validate these scores in any of the trial publications^{1,2,4}, and are unclear how these estimates differ from those identified by the ERG. The ERG suspect that these scores were taken after patients received ASCT, whereas those reported for the Myeloma XI trial are prior to ASCT. As the original ISS scores identified by the ERG for the CALGB 100104 trial are also pre-ASCT, and these demonstrate a difference in the proportion of patients with ISS score III at baseline (see ERG report p. 60), the ERG maintain that there is a difference in this characteristic at baseline between the trials.

Overall, the ERG do not consider the company to have presented additional evidence or justification to resolve heterogeneity between the trials, or to resolve applicability of evidence from the CALGB 100104 to the UK population. As described above, the ERG also consider the GIMEMA trial to be too heterogeneous for inclusion in the economic model.

3.3. Issue 3: The company did not present adverse event data for the observation arm of the target population from Myeloma XI

a) Is maintenance therapy with lenalidomide likely to have an acceptable safety profile?

In response to this issue, the company provided data from CALGB 100104^{1,2} to characterise a comparative safety profile. The issues with generalising CALGB 100104 to Myeloma XI are well-characterised; however, the ERG notes that data from CALGB 100104 are useful to provide a signal of comparative safety profiles. In short, the ERG agrees that lenalidomide is likely to have an acceptable safety profile in terms of grade 3 or 4 events as compared to maintenance; however, Myeloma XI does not provide directly generalisable evidence in this regard.

The ERG also acknowledges the importance of secondary primary malignancies as key adverse events in lenalidomide. However, the ERG was unconvinced by the commentary provided and notes that secondary primary malignancies may impact the acceptability of lenalidomide's safety profile.

b) Are rates of serious adverse events in the intention-to-treat population of Myeloma XI likely to be generalisable to the decision problem cohort?

The company's response to this specific sub issue consisted of clinical opinion and thus did not provide a basis for quantifying how Myeloma XI ITT evidence for serious adverse events would generalise to the decision problem cohort. The clinical advice provided, while plausible, does not describe either to what degree severe adverse events would be lower in the decision problem cohort, nor how this relates to secondary primary malignancies, which the company recognised as being a salient category of adverse events for consideration here.

3.4. Issue 4: Concerns with the company's systematic review of economic evidence

a) Is it appropriate for the company to use alternative sources of costs and resource use rather than those identified by the systematic review?

Following technical engagement, the company provided commentary on the suitability of the four studies identified in the systematic review to inform the healthcare resource use and cost

parameters for the model. The ERG was satisfied that none of the identified studies could have been used to inform the economic model (Table 7), and that the use of alternative sources of costs and resource use was appropriate.

Table 7: Healthcare resource use and costs: summary included studies

Citation	Publication	Country	Population	Healthcare resource use / Costs	Comment
Ashcroft, 2018 ⁵	Full Text (retrospective chart review)	France, Germany, Italy, Spain, UK	Non maintenance (n=312); maintenance (n=25)	HCRU cost UK tariff across treatment pathway by country ^a (€638.14 per mth)	Data included limited UK patients (59 total; 2 maintenance). HCRU cost reported by country but units of use not reported. Studies did not report subsequent treatment costs by type of treatments used in UK practice.
Jackson, 2017 ⁶	Abstract ASH (cost impact model)	France, Germany, Italy, Spain, UK	Non maintenance; ^b maintenance ^c	Post ASCT direct medical costs over 5 yrs	The company noted that the abstract was not accessible. The ERG was able to access the record and noted that only direct medical costs over 5 yrs were reported in the abstract
Jackson 2019 ⁷	Full Text (patient survey & partitioned survival model)	France, Germany, Italy, Spain, UK	NDMM	None reported	No medical care costs reported. Human capital analysis – impact of maintenance therapy on total productivity losses in NDMM patients post-ASCT.
Niphadkar, 2016 ⁸	Abstract ASH (cost comparison)	USA	NDMM: ASCT + maintenance; 1-yr post ASCT	Cost of hospitalisation and cost of length of stay (transplant admission); Cost of subsequent therapy (price x duration of therapy)	Cost of ASCT not included in the company model. Cost of subsequent therapy not relevant to the UK (cost and duration of therapy in the US).

Abbreviations: ASCT, autologous stem cell transplant; ASH, American Society of Haematology; ERG, Evidence Review Group; HCRU, healthcare resource use; HCP, healthcare professional; mth, month; NDMM, newly diagnosed multiple myeloma; UK, United Kingdom; US(A), United States (America); yrs, years

Notes: ^a Hospitalisation; supportive drugs; supportive treatments; HCP visits; monitoring tests; ^b Up to 2 lines of therapy following disease progression after ASCT; ^c 50% 28/28 day dosing & 50% 21/28 day dosing

b) Is the company's systematic review of economic evidence adequately reported?

In its report the ERG raised issues related to the reporting of the company's systematic reviews of economic evidence. These issues were predominantly in respect of the systematic review of health-related quality of life and utilities, and the systematic review of healthcare resource use and costs. Following technical engagement:

- the company provided an updated PRISMA flow diagram and list of included and excluded studies for the systematic review of health-related quality of life and utilities. The ERG was satisfied that the company had clarified the discrepancies in its reporting of the study selection process. There was no impact on the final included studies for the review.
- the company provided additional commentary on the relevance of the included studies in the systematic review of healthcare resource use and costs (refer to Issue 4a above).

Overall, the ERG was satisfied that reporting discrepancies previously identified were resolved.

3.5. Issue 5: The company's method for estimating subsequent treatment costs may not be appropriate

a) For people receiving lenalidomide maintenance therapy following ASCT, which therapies are they likely to receive at 2nd, 3rd and subsequent lines (not including therapies available through the cancer drugs fund [CDF])?

Following TE, the company revised its assumptions of the proportion of subsequent therapies for patients who receive lenalidomide maintenance therapy following ASCT. Table 8 below presents the company original base case (following clarification stage), the company revised base case (following TE) and the ERG base case. The ERG's preferred assumptions are based loosely on the company's base case following clarification stage, and amended based on clinical advice provided to the ERG.

The ERG agrees with the company that, were CDF treatments unavailable,

_____.

Clinical advice provided to the ERG noted that if the CDF regimen (daratumumab + bortezomib + dexamethasone) were no longer an option for patients following relapse then a second ASCT may be considered at the 2nd line. The remaining patients would receive either 'other treatment', likely resembling the CTD regimen, or no treatment.

Without CDF treatments available, a large proportion of patients are expected to receive 'other treatment' following a second relapse (3rd line). The majority of the remaining patients are likely to receive either bortezomib + dexamethasone or panobinostat + bortezomib + dexamethasone at the 3rd line, with some patients receiving no treatment.

Clinical advice to the ERG noted that the proportion of patients receiving *any* subsequent therapy would be equal between treatment arms however, it is likely that more patients would receive no treatment at the 3rd line compared to 2nd line.

Table 8: Company and ERG base case subsequent therapy assumptions - Lenalidomide maintenance

Treatment arm Option	Lenalidomide maintenance					
	Company original base case		ERG base case		Company revised base case	
Line	Post 1st relapse (2 nd line)	Post 2nd relapse (3 rd line)	Post 1st relapse (2 nd line)	Post 2nd relapse (3 rd line)	Post 1st relapse (2 nd line)	Post 2nd relapse (3 rd line)
Len + dex						
Bor + dex	■	■	60.0%	20.0%	■	■
Car + dex						
Pan + bor + dex		■		20.0%		■
ASCT			15.0%		■	
Pom		■				
Other	■	■	20.0%	50.0%	■	■
No treatment	■	■	5.0%	10.0%	■	■

Abbreviations: ASCT, autologous stem-cell transplantation; bor, bortezomib; car, carfilzomib; dex, dexamethasone; ERG, evidence review group; len, lenalidomide; pan, panobinostat; pom, pomalidomide

b) For people receiving observation following ASCT, which therapies are they likely to receive at 2nd, 3rd and subsequent lines (not including therapies available through the cancer drugs fund [CDF])?

Following TE, the company revised its assumptions of the proportion of subsequent therapies for patients who received observation following ASCT. Table 9 below presents the company original base case, the company revised base case, and the ERG base case. As described above, the ERG's preferred assumptions are based primarily on the company's base case following clarification stage, and amended based on clinical advice provided to the ERG. Further details of assumptions made to inform the ERG base case subsequent therapy distributions can be found in Section 4.2.8.4 of the ERG report.

Clinical advice to the ERG noted that were CDF treatments unavailable, the majority of observation patients would receive either lenalidomide + dexamethasone or bortezomib + dexamethasone at the 2nd line. The remaining patients would likely receive 'other treatment', a second ASCT (as mentioned in Issue 5a), or no treatment.

The ERG noted within its report (Section 4.2.8.4) that carfilzomib + dexamethasone cannot be used in the majority of patients following ASCT as induction regimens typically include the use of bortezomib, with NICE TA457 guidance⁹ stating that carfilzomib is recommended only for patients that have not previously received bortezomib. Consequently, the ERG believe that no patients would be eligible for carfilzomib following relapse, assuming all patients are managed per current practice, and therefore, does not consider this option to be relevant for inclusion within the model.

At the factual accuracy check (FAC) stage the company highlighted to the ERG that lenalidomide + dexamethasone is not reimbursed by NICE following first relapse¹⁰. The company provide further evidence within their TE response (p. 11-12), and state that "*Lenalidomide is reimbursed in ASCT-eligible people only from third and subsequent lines [TA171] and this is reflected in the company's revised assumptions*" (p.11). However, the company revised base case contradicts this and assigns █████ of patients to receive lenalidomide + dexamethasone at the 2nd line.

Furthermore, it was indicated to the ERG that it is unlikely there would be a difference in the proportion of patients to receive *any* subsequent treatment between arms. Therefore, the proportion of patients receiving 'no treatment' was set to be equal between lenalidomide maintenance and observation in the ERG base case (5% at 2nd line, 10% at 3rd line).

Following 2nd relapse (3rd line), clinical advice indicated to the ERG that the majority of observation patients would likely receive lenalidomide + dexamethasone, with the remaining patients receiving bortezomib + dexamethasone, panobinostat + bortezomib + dexamethasone, other treatment or no treatment.

Table 9: Company and ERG base case subsequent therapy assumptions - Observation

Treatment arm Option	Observation					
	Company original base case		ERG base case		Company revised base case	
Line	Post 1st relapse (2 nd line)	Post 2nd relapse (3 rd line)	Post 1st relapse (2 nd line)	Post 2nd relapse (3 rd line)	Post 1st relapse (2 nd line)	Post 2nd relapse (3 rd line)
Len + dex	■	■	30.0%	70.0%	■	■
Bor + dex	■	■	40.0%	10.0%	■	■
Car + dex	■				■	
Pan + bor + dex		■		5.0%		■
ASCT			5.0%		■	
Pom						
Other	■	■	20.0%	5.0%	■	■
No treatment	■	■	5.0%	10.0%	■	■

Abbreviations: ASCT, autologous stem-cell transplantation; bor, bortezomib; car, carfilzomib; dex, dexamethasone; ERG, evidence review group; len, lenalidomide; pan, panobinostat; pom, pomalidomide

c) Are people likely to receive a second ASCT? If so, at what point in the treatment pathway?

Clinical advice to the ERG noted that if the CDF regimen; daratumumab + bortezomib + dexamethasone, was no longer an option for patients following relapse then a second ASCT may be considered at the 2nd line (post 1st relapse).

The company notes they conducted a physician survey of subsequent therapies following 1st and 2nd relapse with no physician indicating they would consider a second ASCT as a treatment option. Importantly however, the survey conducted included CDF regimens as subsequent therapy options. Clinical advice to the ERG noted that if CDF treatments are available then a second ASCT would be unlikely as other treatment options are preferable. However, if CDF treatments were hypothetically not an option, the treatment pathway would look considerably different for patients following relapse. In this scenario, the clinical experts indicated that a second ASCT may be considered at the 2nd line for some patients, largely due to a lack of other options.

The company refers to the low proportion of patients who received a second ASCT in the Myeloma XI trial (■ of lenalidomide maintenance and ■ of observation patients). The ERG highlight that patients received a large range of subsequent therapies in Myeloma XI, including CDF regimens, as well as treatments that are now considered 'out-dated' and therapies used in lines where NICE reimbursement is unavailable (CS Appendix P Table 65). The model

constructed by the company is not able to capture the health effects of specific subsequent treatments and therefore no adjustments to overall survival can be made that account for differentiation between the Myeloma XI trial and current NHS practice. The ERG's opinion is that the subsequent therapies used in Myeloma XI lack generalisability to current NHS practice and therefore should not be used to inform estimates for or against subsequent therapy assumptions.

In the company's response to TE Issue 5c (p. 12-13) it states '*The ERG's differential assumptions of 15% of patients for the lenalidomide arm and 5% for observation is not supported by clinical experts.*'. This statement is incorrect as the ERG base case was presented to clinical experts for the ERG with no issues raised regarding the difference in proportions between arms. The differential proportions for a second ASCT between the arms is based on the assumption that patients treated with lenalidomide maintenance are more likely to be in a health state eligible for a second ASCT. This assumption was supported by clinical advice provided to the ERG.

The company go on to state (in response to TE Issue 5c, p.12-13) that "*this contradicts the ERG's own clinical advice (section 4.2.8.4 of the ERG report) that patients would be expected to receive any subsequent treatment across both arms in similar proportions (with an exception pertaining to the re-use of lenalidomide)*". The statement in the ERG report (Section 4.2.8.4) is as follows "*Clinical advice provided to the ERG clarified that there is no evidence to suggest a difference in the proportion of patients that would receive **any** subsequent treatment based on whether or not a patient was managed with lenalidomide maintenance or not (except that patients who have previously received lenalidomide would not receive another lenalidomide-containing regimen)*". The ERG recognise that this statement is potentially misleading. For clarity, the clinical advice referred to by the ERG relates to the proportion of patients to receive treatment (of any kind) versus those who receive *no* treatment at all, and not to the proportion of patients receiving a particular therapy to be equal between arms (excluding lenalidomide regimens) as is implied by the company's interpretation of the statement. The clinical advice provided to the ERG simply noted that the proportion of patients receiving no treatment at the 2nd and 3rd lines is expected to be equal between arms.

The company also state "*...it does not technically qualify as a second-line therapy for a patient that has relapsed/ is relapsing on maintenance therapy...*" when discussing a second ASCT

following relapse. The ERG is unsure what the company is referring to here and considers that a second ASCT qualifies as a second-line therapy.

d) Are the company's or the ERG's assumptions about subsequent treatments most appropriate?

The ERG agree with the company that the exclusion of CDF therapies does not reflect current UK practice and creates high levels of uncertainty with respect to subsequent therapies. However, clinical advice obtained by the ERG indicated that if no CDF regimens were available as treatment options then the ERG's base case assumptions were plausible.

A limitation in both the company and ERG base cases is the assumed use of lenalidomide + bortezomib in the 2nd line which is not reimbursed by NICE at that position in the treatment pathway (details in Issue 5b, above).

Further limitations of the company revised base case include the use of carfilzomib + dexamethasone for observation patients in the 2nd line, and unequal proportions of patients receiving no treatment at the 3rd line between arms (■ for lenalidomide maintenance and ■ for observation).

In the absence of any new information / data available to revise estimates, the ERG has chosen not to revise their base case assumptions relating to subsequent therapies. The ERG acknowledges there is substantial uncertainty around treatments which would be administered in UK practice in the absence of CDF regimens, and given the ICER is highly influenced by assumptions made, the ERG believes that the subject requires further discussion at the committee meeting.

3.6. Issue 6: The company provided highly uncertain estimates of overall survival, and the company and ERG disagree on which distribution to use for extrapolation

Following TE, the company has produced an updated analysis of the clinical data wherein the Myeloma XI and CALGB 100104^{1,2} data are pooled. Details of the new analysis and ERG review are provided in Section 2.1.

a) Should a joint model or independent models be used to extrapolate OS?

The ERG considered the log-cumulative hazard and Q-Q plots provided in the company submission (CS Document B Figure 10, p.69) as reasonable evidence to support both the proportional hazards (PH) and constant acceleration factor (AF) assumptions between

lenalidomide maintenance and observation in overall survival. Therefore, the ERG base case includes extrapolation with a joint model to the Myeloma XI data.

Originally the company fitted independent models to each treatment arm however, in the revised analysis (using pooled data), the company chose a joint model to extrapolate OS.

b) If independent models are chosen, is a log-logistic model appropriate for extrapolation of the lenalidomide maintenance arm and a Weibull model appropriate for extrapolation of the observation arm?

Joint models are now the preferred base case for both the company and ERG. A critique of the company's revised survival extrapolations is detailed in Section 2.1.

c) How many patients are expected to be alive at 10 years in the lenalidomide arm? Is [REDACTED] a reasonable estimate?

In the company's response to TE Issue 6c (p. 14) they state '*With lenalidomide maintenance, the proportion of people alive at 10 years is [REDACTED]*'. The ERG's preferred base case estimates that [REDACTED] of patients in the lenalidomide arm would be alive at 10 years (comparison provided in ***[REDACTED]1). Clinical advice provided to the ERG noted that 10-year survival for patients that have undergone ASCT, with or without maintenance therapy, would be expected to be higher than the whole multiple myeloma population; owing to the better prognosis of ASCT-eligible versus ASCT-ineligible patients.

d) Is the company's ([REDACTED]) or the ERG's ([REDACTED]) estimate of the number of people alive after 10 years in the observation arm most appropriate?

In the company's response to TE Issue 6c (p. 14) they state '*With lenalidomide maintenance, the proportion of people alive at 10 years is ... [REDACTED] with observation*'. However, when taken directly from their revised economic model, the company's new estimate for the proportion of patients alive at 10 years in the observation arm is [REDACTED] (comparison provided in ***[REDACTED]1).

The Office for National Statistics (ONS)¹¹ and Cancer research UK (CRUK)¹² estimate 29% and 33% 10-year survival for people with Multiple Myeloma (MM), respectively. In the company's response to TE they highlight that there may be an overlap between the patients included in the ONS estimate with participants in the Myeloma XI study. As a result, the ONS estimate is likely to have some confounding due to the inclusion of some patients treated with lenalidomide maintenance, potentially inflating the estimate of 10-year survival. However, the ERG note that the ONS estimate is of the MM population as a whole, including ASCT-ineligible patients. Clinical advice provided to the ERG noted that ASCT-eligible patients are expected to have a

greater 10-year survival compared to ASCT-ineligible patients. Therefore, it is also possible that the ONS estimate may be lower than expected for a patient that has undergone an ASCT.

The company original base case extrapolations indicated ■ of observation patients would be alive, which was revised to ■ in TE. The ERG's base case was 32.44%, which lies much closer to the ONS (29%) and CRUK (33%) predictions.

e) Is it appropriate to use CALGB 100104 data to inform OS curve model selection? If so, was the company correct to choose the rank preserving structural failure time (RPSFT) method to adjust for treatment switching in CALGB 100104, and why?

The ERG believes that while the CALGB 100104^{1,2} data provide an insight into how the pattern of survival may change over time, it is not appropriate to base OS model curve selection on this data due to several key limitations. These limitations are outlined in further detail in the ERG report Section 4.2.6.1. (p. 60-61) and summarised briefly below:

- No patients enrolled in CALGB 100104 were from the UK
- Patients were treated with the licensed dosing regimen of 10mg on Days 1-28 of a 28-day treatment cycle (as opposed to 10mg on days 1-21 of a 28-day cycle in Myeloma XI)
- Duration of treatment was shorter in CALGB 100104 versus Myeloma XI
- CALGB 100104 OS estimates were confounded by treatment switching
 - The company adjusted for switching using the RPSFT method but the need to adjust for crossover nevertheless introduces additional uncertainty into the estimation of OS
- The impact of subsequent treatments is unclear

Furthermore, the ERG reported concerns regarding the frequency of patients with international staging system (ISS) disease stage III at baseline, which differed between the Myeloma XI (■) and CALGB 100104 (2%) trials. In the company's response to TE addendum, figures of a much closer match are provided in Table 1: ■ for Myeloma XI and 16.5% for CALGB 100104. It is unclear to the ERG where these figures were identified from: the company state that these can be found in the primary publication for CALGB 100104² though the ERG are unable to match these values to the ones provided in company TE addendum. The ERG expect that the figures reported by the company are for ISS scores post-ASCT, however without the referenced source the ERG are unable to confirm this. Furthermore, as ISS stage was collected pre-ASCT

in Myeloma XI, the ERG considers it appropriate to compare these scores with those identified by the ERG, and therefore maintain that there is a difference in this characteristic between patients at baseline.

For the aforementioned reasons, the ERG does not consider the use of CALGB 100104 data to inform OS curve model selection to be appropriate and believes curve selection should be based solely on data from the Myeloma XI trial. Therefore, the appropriateness of any crossover analysis in CALGB 100104 has not been considered.

f) Is there likely to be a waning of treatment effect with lenalidomide maintenance therapy? Or is the company's assumption of [REDACTED] more realistic?

In the absence of long-term data to measure the effectiveness of lenalidomide maintenance treatment in the long-term (~10 years), the ERG felt the assumption of a constant lifetime treatment effect could potentially be optimistic. Therefore, the ERG conducted a scenario analysis where the longevity of treatment effect, and its impact on the ICER, could be investigated (details found in ERG report Section 6.6.1.).

In the company's response to TE Issue 6f (p. 17) they describe log-cumulative hazard plots as providing evidence that PH will remain in the long term. While the plots provide evidence of PH throughout both the Myeloma XI and CALGB 100104^{1,2} trials, they provide no evidence that the PH assumption holds indefinitely. Further to this, the revised base case presented is informed by a joint Weibull model, which inherently assumes the treatment effect holds across the entire duration of the model. The ERG does not include the waning treatment effect of lenalidomide maintenance within its preferred base case analysis (as an AFT model has been specified) but believes that in the absence of long-term data, this scenario could be potentially plausible. Applying a discontinuation of the treatment effect was highly influential on the ICER if it was applied between 5 (starting point) and 15 years. Beyond this, the model was relatively insensitive to treatment effect changes (details found in Figure 12, Section 4.2.6.1 of the ERG report)

3.7. Issue 7: Uncertain impact of dose adjustments and wastage on drug costs

As discussed in Section 2.3, the company provided a new RDI estimate, calculated from Myeloma XI data, which has been incorporated into their revised base case. There is an increase in the expected RDI from the original estimate: in the original CS, RDI from Myeloma XI was reported to be [REDACTED], whereas the revised RDI is [REDACTED]. These modifications have been

implemented to address specific aspects of the ERG critique of these issues (ERG report Section 4.2.8.1., p. 73). At clarification, the ERG requested information on how drug wastage was accounted for in the calculation of RDI, though the company did not provide an answer to this. This change at TE implies that no account for drug wastage was made in the original calculation.

From the information provided by the company during TE, it is clear that the Myeloma XI trial did not directly measure the prescribed versus the actual dose received by patients, including a reliable estimate of wastage. In order to address ERG concerns therefore, the company have used a series of calculations, involving a series of assumptions, using the patient-level data that was available to provide an estimate of RDI. A further complexity in the calculation is that different approaches to measuring the dose received by patients were used between protocol v5 and v6 of the Myeloma XI trial. Under v5 of the protocol, the start date and total dose prescribed for each cycle was collected only, meaning that more assumptions were needed about the way treatment was received and where wastage occurred. Under protocol v6, information was collected on whether the cycles were received as prescribed ('per protocol'); if not, the cycle was described reduced, delayed, or omitted. However, the exact data that was used to inform this categorisation was not reported in the company's TE response.

The ERG considered that the description of the way dose was estimated, and wastage was then assumed, described in the company's TE response from the Myeloma XI data was difficult to follow. Where clear assumptions were given, these appeared to be reasonable. However, the ERG identified a number of gaps in the description of how the calculations were conducted. Overall, the ERG considered that the description is not transparent enough to be validated by the ERG without further clarity and data. Further, the ERG noted that there was a slight discrepancy in the proportions reported in the addendum submitted by the company compared to the calculations within the model itself. As any calculation of RDI from the data measured under either protocol v5 or v6 requires a series of assumptions, it is therefore the case that any estimate would be highly uncertain. The ERG therefore did not consider it appropriate to change their base case assumptions from those reported in the ERG report (94.9%). The ERG has explored the impact of RDI on the ERG base case assumptions using [REDACTED] (the company's original RDI estimate) as a lower bound and 100% as an upper bound. Results of this exploratory analysis are presented in ***[REDACTED]3. With an ERG base case of £40,751 (with a corresponding RDI of 95%), applying the company's revised RDI of [REDACTED] decreases the ICER by £4,281 to £36,470. The ERG believe that the model is sensitive assumptions made around RDI.

3.8.

3



Issue 8: Whether medical resource use should differ between treatments and between relapse status

Clinical advice to the ERG indicated that the medical resource use (MRU) for patients receiving active treatment would likely be greater due to an increase in follow-up appointments compared to patients managed by observation. Therefore, in the ERG's preferred base case analysis, the frequency of outpatient appointments (oncologist/haematologist visits) were halved for those on observation, compared to lenalidomide maintenance, prior to 1st relapse.

Following relapse, the majority of patients in either arm were expected to receive an active subsequent therapy. The ERG believes that MRU would vary as patients progress through the treatment pathway, however due to the PartSA model structure there is no clear way to apply variable MRU costs. Therefore, in the ERG's preferred base case, no difference between treatments is assumed in MRU post-relapse. Furthermore, it is assumed that MRU post-progression is the same as the pre-progression MRU in the observation arm (See Section 4.2.8.2 of the ERG report for further details).

In the company's response to TE, they accept the ERG's preferred assumptions regarding MRU and state these have been incorporated within their revised base case. However, as outlined in Section 2, the implementation of the assumptions in the company's revised economic model have not been performed correctly:

- The company have halved all MRU frequencies (and subsequently costs) for observation patients versus lenalidomide maintenance patients. The correct implementation should have seen the frequency of outpatient (oncologist/haematologist) visits halved only.
- Consequently, as the observation post-progression MRU are assumed to be equal to the MRU in the observation arm prior to relapse, the post-relapse MRU costs are also incorrect.
- The pre- and post-progression MRU for lenalidomide maintenance are assumed to be equal in the company's revised analysis. The correct application of the ERG's assumption should have set the post-progression lenalidomide maintenance MRU equal to pre-progression observation MRU

Table 10 presents the MRU costs applied in the ERG base case and the company revised base case.

Table 10: Medical resource use costs applied in ERG and company base case

Arm	MRU costs			
	Lenalidomide		Observation	
Progression state	Pre-relapse	Post-relapse	Pre-relapse	Post-relapse
ERG base case	£255	£173	£173	£173
Company revised base case	£255	£255	£127	£127

Abbreviations: MRU, medical resource use

When applying the ERG's MRU assumptions correctly, the company revised base case changes from ██████ to ██████. However, the ERG highlights that this estimated ICER is subject to further ERG assumptions accepted by the company that have also been applied incorrectly. Section 2.5 presents the company revised base case when all accepted ERG assumptions are applied correctly.

4. REFERENCES

1. McCarthy PL, Owzar K, Hofmeister CC, Hurd DD, Hassoun H, Richardson PG, et al. Lenalidomide after stem-cell transplantation for multiple myeloma. *N Engl J Med*. 2012;366(19):1770–81.
2. Holstein SA, Jung SH, Richardson PG, Hofmeister CC, Hurd DD, Hassoun H, et al. Updated analysis of CALGB (Alliance) 100104 assessing lenalidomide versus placebo maintenance after single autologous stem-cell transplantation for multiple myeloma: a randomised, double-blind, phase 3 trial. *Lancet Haematol*. 2017;4(9):e431–e42.
3. Palumbo A, Cavallo F, Gay F, Di Raimondo F, Ben Yehuda D, Petrucci MT, et al. Autologous transplantation and maintenance therapy in multiple myeloma. *N Engl J Med*. 2014;371(10):895–905.
4. McCarthy PL, Holstein SA, Petrucci MT, Richardson PG, Hulin C, Tosi P, et al. Lenalidomide maintenance after autologous stem-cell transplantation in newly diagnosed multiple myeloma: a meta-analysis. *J Clin Oncol*. 2017;35(29):3279–89.
5. Ashcroft J, Judge D, Dhanasiri S, Taylor-Stokes G, Middleton C. Chart review across EU5 in MM post-ASCT patients. *Int J Hematol Oncol*. 2018;7(1):IJH05-IJH.
6. Jackson G, Dutton R, Zamagni E, Hughes R, Dhanasiri S. Lenalidomide Maintenance Therapy Post-Autologous Stem Cell Transplant: A Healthcare Cost-Impact Analysis in Europe. *Blood*. 2017;130(Supplement 1):3405-.
7. Jackson GH, Davies FE, Pawlyn C, Cairns DA, Striha A, Collett C, et al. Lenalidomide maintenance versus observation for patients with newly diagnosed multiple myeloma (Myeloma XI): a multicentre, open-label, randomised, phase 3 trial. *Lancet Oncol*. 2019;20(1):57–73.
8. Niphadkar S, Varadarajan I, Pompa T, Hou KY, Degen K, Vazquez-Martinez M, et al. Autologous Stem Cell Transplant: A Cost Effective and Efficacious Treatment for Newly Diagnosed Multiple Myeloma. *Blood*. 2016;128(22):2358-.
9. National Institute for Health and Care Excellence. TA457. Carfilzomib for previously treated multiple myeloma, 19 July 2017. Available from: <https://www.nice.org.uk/guidance/ta457>. (Accessed 30 September 2019).
10. National Institute for Health and Care Excellence. TA171. Lenalidomide for the treatment of multiple myeloma in people who have received at least one prior therapy, 26 June 2019. Available from: <https://www.nice.org.uk/guidance/ta171> (Accessed 30 September 2019)
11. Office for National Statistics. Cancer registration statistics, England 2017. Available from: <https://www.ons.gov.uk/peoplepopulationandcommunity/healthandsocialcare/conditionsanddiseases/bulletins/cancerregistrationstatisticsengland/2017> (Accessed 09 December 2019).
12. Cancer Research UK. Myeloma survival statistics, December 2014. Available from: <https://www.cancerresearchuk.org/health-professional/cancer-statistics/statistics-by-cancer-type/myeloma/survival#heading-Zero>. (Accessed 3 January 2020)