

Single Technology Appraisal

Dapagliflozin for treating chronic heart failure with preserved or mildly reduced ejection fraction [ID1648]

Committee Papers

NATIONAL INSTITUTE FOR HEALTH AND CARE EXCELLENCE

SINGLE TECHNOLOGY APPRAISAL

Dapagliflozin for treating chronic heart failure with preserved or mildly reduced ejection fraction [ID1648]

Contents:

The following documents are made available to stakeholders:

[Access the **final scope** and **final stakeholder list** on the NICE website.](#)

1. **Company submission** from AstraZeneca UK Ltd
2. **Clarification questions and company responses**
3. **Patient group, professional group and NHS organisation submissions** from:
 - a. UK Clinical Pharmacy Association – Heart Failure Committee
4. **Expert personal perspectives** from:
 - a. Sarah Worsnop – patient expert, nominated by Pumping Marvellous Foundation
 - b. Nick Hartshorne-Evans – patient expert, nominated by Pumping Marvellous Foundation
 - c. Lisa Anderson – clinical expert, nominated by British Society for Heart Failure
 - d. Andrew Ludman – clinical expert, nominated by British Cardiovascular Society
5. **External Assessment Report** prepared by BMJ-TAG
6. **External Assessment Report – factual accuracy check**
7. **External Assessment Report addendum** prepared by BMJ-TAG
8. **External Assessment Group summary of direct and indirect treatment effects** prepared by BMJ-TAG

Any information supplied to NICE which has been marked as confidential, has been redacted. All personal information has also been redacted.

NATIONAL INSTITUTE FOR HEALTH AND CARE EXCELLENCE

Single technology appraisal

Dapagliflozin for treating chronic heart failure with preserved or mildly reduced ejection fraction [ID1648]

Document B

Company evidence submission

September 2022

File name	Version	Contains confidential information	Date
[ID1648] Dapagliflozin HF LVEF greater than 40%_Document B	1.0	Yes	14 th September 2022

Instructions for companies

This is the template for submission of evidence to the National Institute for Health and Care Excellence (NICE) as part of the single technology appraisal (STA) process. Please note that the information requirements for submissions are summarised in this template; full details of the requirements for pharmaceuticals and devices are in the [user guide](#).

This submission must not be longer than 150 pages, excluding appendices and the pages covered by this template. If it is too long it will not be accepted.

Companies making evidence submissions to NICE should also refer to the NICE [health technology evaluation guidance development manual](#).

In this template any information that should be provided in an appendix is listed in a box.

Highlighting in the template (excluding the contents list)

Square brackets and ■ highlighting are used in this template to indicate text that should be replaced with your own text or deleted. These are set up as form fields, so to replace the prompt text in ■ with your own text, click anywhere within the highlighted text and type. Your text will overwrite the highlighted section.

To delete grey highlighted text, click anywhere within the text and press DELETE.

Grey highlighted text in the footer does not work as an automatic form field, but serves the same purpose – as prompt text to show where you need to fill in relevant details. Replace the text highlighted in ■ in the header and footer with appropriate text. (To change the header and footer, double click over the header or footer text. Double click back in the main body text when you have finished.)

Contents

Instructions for companies	2
Contents	3
Tables and figures.....	4
Abbreviations	7
B.1. Decision problem, description of the technology and clinical care pathway.....	11
B.1.1. Decision problem.....	11
B.1.2. Description of the technology being evaluated	15
B.1.3. Health condition and position of the technology in the treatment pathway	16
B.1.4. Equality considerations	27
B.2. Clinical effectiveness	28
B.2.1. Identification and selection of relevant studies	28
B.2.2. List of relevant clinical effectiveness evidence	29
B.2.3. Summary of methodology of the relevant clinical effectiveness evidence	32
B.2.4. Statistical analysis and definition of study groups in the relevant clinical effectiveness evidence	40
B.2.5. Critical appraisal of the relevant clinical effectiveness evidence	43
B.2.6. Clinical effectiveness results of the relevant studies: DELIVER.....	44
B.2.7. Subgroup analysis.....	53
B.2.8. Prespecified analysis: estimated benefits with long-term treatment with dapagliflozin ..	55
B.2.9. Meta-analysis	56
B.2.10. Indirect and mixed treatment comparisons	61
B.2.11. PRESERVED-HF trial outcome summary	61
B.2.12. Adverse reactions.....	68
B.2.13. Ongoing studies	75
B.2.14. Interpretation of clinical effectiveness and safety evidence.....	75
B.3. Cost effectiveness	79
B.3.1. Published cost-effectiveness studies	80
B.3.2. Economic analysis.....	80
B.3.3. Clinical parameters and variables	85
B.3.4. Measurement and valuation of health effects	101
B.3.5. Cost and healthcare resource use identification, measurement and valuation	103
B.3.6. Severity.....	107
B.3.7. Uncertainty	108
B.3.8. Summary of base case analysis inputs and assumptions	108
B.3.9. Base case results	116
B.3.10. Exploring uncertainty.....	117
B.3.11. Subgroup analysis.....	123
B.3.12. Benefits not captured in the QALY calculation	123
B.3.13. Validation.....	123
B.3.14. Interpretation and conclusions of economic evidence	126
References	127
B.4. Appendices	134

Tables and figures

Table 1: The decision problem	11
Table 2: Technology being evaluated.....	15
Table 3: Classifications of HF across major international HF guidelines	17
Table 4: NYHA classification criteria.....	21
Table 5: KCCQ questionnaire domains and summary scores	22
Table 6: Clinical effectiveness evidence.....	30
Table 7: Summary of trial methodology: DELIVER	32
Table 8: Characteristics of participants in DELIVER across treatment groups.....	36
Table 9: Summary of statistical analyses in DELIVER.....	40
Table 10: Critical appraisal of DELIVER.....	43
Table 11: Analysis of the composite endpoint of CV mortality and recurrent HF events in DELIVER.....	47
Table 12: Summary of HF events and CV mortality – number of events per patient in DELIVER.....	47
Table 13: Summary of adjudicated death classification in DELIVER ^a	49
Table 14: Change in KCCQ parameters at Month 1, Month 4 and Month 8.....	50
Table 15: Analysis of first occurrence of hospitalisation from any cause in DELIVER	52
Table 16: Effect of dapagliflozin versus placebo on NYHA functional class over time ^a	53
Table 17: Primary composite endpoint (CV mortality and HF events) in patients with HFimpEF compared with those with HF and an LVEF consistently >40%.....	55
Table 18: Baseline characteristics of the patients included in the pooled analysis of DELIVER and DAPA-HF by LVEF category	58
Table 19: Summary of trial methodology: PRESERVED-HF	62
Table 20: Characteristics of participants in PRESERVED-HF across treatment groups.....	65
Table 21: Primary and secondary endpoints at 12 weeks after treatment initiation in PRESERVED-HF.....	67
Table 22: Number of patients with AEs in any category in DELIVER – on treatment.....	70
Table 23: Number of patients with SAEs (≥ 0.5%) by preferred term in DELIVER – On treatment	71
Table 24: Safety analysis in PRESERVED-HF	72
Table 25: Adverse drug reactions reported in the SmPC for dapagliflozin: adverse reactions in placebo-controlled clinical studies ^a and postmarketing experience	74
Table 26: Summary of the key differences in modelling approaches between TA679 versus this appraisal.....	80
Table 27: Key features of the economic analysis.....	83
Table 28: Patient demographic characteristics incorporated in the base case economic analysis	85
Table 29: Patient clinical characteristics incorporated in the base case economic analysis	85
Table 30: Patient medical history incorporated in the base case economic analysis	86
Table 31: Patient demographic characteristics based on the UK CPRD dataset used in a scenario analysis.....	86
Table 32: Patient clinical characteristics based on the UK CPRD dataset used in a scenario analysis	87
Table 33: Patient medical history based on the UK CPRD dataset used in a scenario analysis ..	87
Table 34: Monthly KCCQ-TSS transition matrix.....	88
Table 35: AIC and BIC values of the unadjusted parametric survival model distributions for CV mortality derived from the DELIVER ITT population	91
Table 36: AIC and BIC values of the unadjusted parametric survival model distributions for all-	

cause mortality derived from the DELIVER ITT population.....	91
Table 37: AIC and BIC values of the adjusted parametric survival model distributions for CV mortality derived from the DELIVER ITT population	92
Table 38: AIC and BIC values of the adjusted parametric survival model distributions for all-cause mortality derived from the DELIVER ITT population.....	92
Table 39: Age and sex-stratified mortality rates derived from WHO global health estimates.....	97
Table 40: Adjusted GEEs predicting HHF events	98
Table 41: Adjusted GEEs predicting UHFV events	99
Table 42: Unadjusted GEE coefficients derived from the DELIVER trial	100
Table 43. Adverse event frequency observed in DELIVER	100
Table 44: Annual probability of AEs.....	100
Table 45: Health state utility values used in the base case economic analysis.....	101
Table 46: Utility decrements used for HF events.....	102
Table 47. Utility decrements used for AEs	102
Table 48: Summary of utility values used in base case economic analysis.....	103
Table 49: Annual drug acquisition costs applied within the cost-effectiveness analysis	104
Table 50: Event costs for transient events and mortality.....	105
Table 51: Health state resource use and frequency and unit costs	105
Table 52: Unit costs used for health state costs	106
Table 53: Unit costs for adverse events	106
Table 54: Summary features of QALY shortfall analysis.....	107
Table 55: Summary of health state benefits and utility values for QALY shortfall analysis	107
Table 56: Summary of QALY shortfall analysis	108
Table 57: Summary of variables applied in the economic model.....	108
Table 58: Summary of assumptions in the base case economic analysis.....	114
Table 59: Base case economic analysis results – ICERs	116
Table 60: Base case economic analysis results – NHB.....	116
Table 61: Base case PSA results	117
Table 62: Summary of scenario analyses	120
Table 63. Statistics from the internal validation of event rates.....	125
Figure 1: Summary of NICE NG106 diagnostic pathway for HF	20
Figure 2: Summary of pharmacologic treatments for patients with HF and an LVEF >40% recommended in NG106.....	23
Figure 3: Current treatment pathway for patients with HF and an LVEF >40% in NG106 and proposed positioning of dapagliflozin.....	26
Figure 4: DELIVER trial design	35
Figure 5: Testing procedure for DELIVER.....	42
Figure 6: Patient disposition in DELIVER	43
Figure 7: KM plot of the primary composite endpoint (CV mortality and HF events) in DELIVER45	
Figure 8: Forest plot of the primary composite endpoint (CV mortality and HF events) and the individual components in DELIVER ^a	46
Figure 9: KM plot of CV mortality in DELIVER	48
Figure 10: KM plot of all-cause mortality in DELIVER.....	49
Figure 11: Mean changes in KCCQ domains over time by treatment allocation ^{a,b}	50
Figure 12: Responder analyses of clinically meaningful change in KCCQ domains at 8 months with dapagliflozin versus placebo ^a	51
Figure 13: Forest plot of the primary composite endpoint (CV mortality and HF events) by subgroups in DELIVER	54

Figure 14: Effect of dapagliflozin on key clinical outcomes in pooled DAPA-HF and DELIVER dataset.....	60
Figure 15: Effect of randomised treatment on CV mortality according to the prespecified subgroups ^a	61
Figure 16: Effects of dapagliflozin on the primary endpoint and its components.....	68
Figure 17: KM plot of the cumulative percentage of patients with premature permanent discontinuation of treatment in DELIVER ^a	72
Figure 18: Schematic of Markov state-transition model structure, health states, and possible transitions.....	82
Figure 19: KM curves for CV mortality in the DELIVER trial, stratified by treatment.....	89
Figure 20: KM curves for all-cause mortality in the DELIVER trial, stratified by treatment.....	90
Figure 21: Adjusted survival model extrapolations for CV mortality ^a	93
Figure 22: Adjusted survival model extrapolations for all-cause mortality ^a	94
Figure 23: Adjusted all-cause mortality predictions for patients receiving placebo in the DELIVER trial compared with meta-analysed 5-year survival reported in Jones <i>et al.</i> (2019) ^{116a}	95
Figure 24: Adjusted all-cause mortality predictions for patients receiving placebo in the DELIVER trial compared with long-term survival reported in Shahim <i>et al.</i> (2021) ^{117a}	96
Figure 25: Cost-effectiveness scatter plot from PSA.....	117
Figure 26: Cost-effectiveness acceptability curve from PSA.....	118
Figure 27: ICER convergence plot from PSA.....	118
Figure 28: Tornado plot of DSA results.....	119
Figure 29: Internal validation of survival for the DELIVER ITT population ^a	124
Figure 30: Internal validation of predicted versus observed event rates for the DELIVER ITT population ^a	125

Abbreviations

6MWT	6 minute walk test
A&E	Accident and emergency
ACC	American College of Cardiology
ACE	Angiotensin converting enzyme
ACEi	Angiotensin converting enzyme inhibitor
AE	Adverse event
AF	Atrial fibrillation
AFF	Atrial fibrillation/flutter
AFT	Accelerated failure time
AHA	American Heart Association
AIC	Akaike information criteria
AKI	Acute kidney injury
ARB	Angiotensin-receptor blocker
ARNI	Angiotensin receptor neprilysin inhibitor
ARR	Absolute risk reduction
ARVC	Arrhythmogenic right ventricular cardiomyopathy/dysplasia
BIC	Bayesian information criterion
BMI	Body mass index
BNF	British National Formulary
BNP	B-type natriuretic peptide
CABG	Coronary artery bypass graft
CAD	Coronary artery disease
CCB	Calcium channel blockers
CI	Confidence interval
CII	Cost inflation index
CKD	Chronic kidney disease
COPD	Chronic obstructive pulmonary disease
CPRD	Clinical Practice Research Datalink
CRF	Case report form
CRT-D	Cardiac resynchronisation therapy – defibrillator
CSR	Clinical study report
CSS	Clinical Summary Score
CV	Cardiovascular
CVD	Cardiovascular disease
DAE	Adverse event leading to treatment discontinuation
Dapa	Dapagliflozin
DKA	Diabetic ketoacidosis
DMC	Data monitoring committee
DSA	Deterministic sensitivity analysis
DSU	Decision support unit
EAG	External assessment group
ECG	Echocardiogram

EEPRU	Economic Methods of Evaluation in Health and Social Care Policy Research Unit
EMC	Electronic medicines compendium
eGFR	Estimated glomerular filtration rate
EPI	Epidemiology
EQ-5D-3L	EuroQol-5 Dimensions-3 Levels
EQ-5D-5L	EuroQol-5 Dimensions-5 Levels
ESC	European Society of Cardiology
FAS	Full analysis set
GEE	Generalising estimating equation
GFR	Glomerular filtration rate
GP	General practitioner
HbA1c	Haemoglobin A1c
HDL	High density lipoprotein
HF	Heart failure
HFA	Health Failure Association
HFSA	Heart Failure Society of America
HHF	Hospitalisation for heart failure
HOCM	Hypertrophic obstructive cardiomyopathy
HR	Hazard ratio
HFimpEF	Heart failure with an improved ejection fraction
HFmrEF	Heart failure with a mildly reduced ejection fraction
HFpEF	Heart failure with a preserved ejection fraction
HFrEF	Heart failure with a reduced ejection fraction
HTA	Health technology assessment
ICD	Implantable cardioverter defibrillator
ICER	Incremental cost-effectiveness ratio
IHD	Ischaemic heart disease
IP	Investigational product
IQR	Interquartile range
ITT	Intention-to-treat
IUD	Intrauterine device
JHFS	Japanese Heart Failure Society
KCCQ	Kansas City Cardiomyopathy Questionnaire
KCCQ-CSS	Kansas City Cardiomyopathy Questionnaire Clinical Summary Score
KCCQ-OSS	Kansas City Cardiomyopathy Questionnaire Overall Summary Score
KCCQ-PLS	Kansas City Cardiomyopathy Questionnaire Physical Limitation Score
KCCQ-TSS	Kansas City Cardiomyopathy Questionnaire Total Symptom Score
KM	Kaplan-Meier
LAE	Left atrial enlargement
LDL	Low density lipoprotein
LV	Left ventricular
LVEDP	Left ventricular end diastolic pressure
LVEF	Left ventricular ejection fraction

LVH	Left ventricular hypertrophy
LWYY	Lin Wei Yang Ying
LYG	Life years gained
MACE	Major adverse cardiovascular events
MAPE	Mean absolute percentage error
MDRD	Modification of diet in renal disease
MHRA	Medicines and Healthcare Products Regulatory Agency
MIMS	Monthly Index of Medical Specialties
MRA	Mineralocorticoid-receptor antagonist
MRI	Magnetic resonance imaging
MSLAR	Mean squared log of the accuracy ratio
MSLE	Mean squared logit error
N	Number of patients in treatment group
N/A	Not applicable
NHB	Net health benefit
NHS	National Health Service
NHSCII	National Health Service Cost Inflation Index
NICE	National Institute for Health and Care Excellence
NNT	Number needed to treat
NSTEMI	Non ST-elevation myocardial infarction
NT-proBNP	N-terminal pro B-type natriuretic peptide
NYHA	New York Heart Association
ONS	Office for National Statistics
OSS	Overall Summary Score
PACD	Primary Analysis Censoring Date
PCI	Percutaneous coronary intervention
PLS	Physical limitation score
PRISMA	Preferred Reporting Items for Systematic Reviews and Meta-Analyses
PSA	Probabilistic sensitivity analysis
PSS	Personal Social Services
PSSRU	Personal Social Services Research Unit
PT	Preferred term
QALE	Quality-adjusted life expectancy
QALY	Quality-adjusted life year
QIC	Quasi-information criterion
QoL	Quality of life
RCT	Randomised controlled trial
RMSPE	Root mean squared percentage error
RR	Rate ratio
RWE	Real-world evidence
SAE	Serious adverse event
SAS	Safety analysis set
SBP	Systolic blood pressure
SCV	Study closure visit

SD	Standard deviation
SE	Standard error
SGLT2	Sodium-glucose-co-transporter-2
SLR	Systematic literature review
SmPC	Summary of Product Characteristics
SoC	Standard of care
STA	Single technology appraisal
STEMI	ST-elevation myocardial infarction
TA	Technology assessment
TIA	Transient ischemic attack
TSD	Technical support document
TSS	Total Symptom Score
UHFV	Urgent heart failure visit
UKPDS	United Kingdom Prospective Diabetes Study
UTI	Urinary tract infection
WHO	World Health Organisation
WTP	Willingness-to-pay threshold

B.1. Decision problem, description of the technology and clinical care pathway

B.1.1. Decision problem

This submission aims to demonstrate the clinical and cost-effectiveness of dapagliflozin as a treatment for patients with chronic heart failure (HF) and a left ventricular ejection fraction (LVEF) >40%. This population is covered under the technology's anticipated expanded marketing authorisation for this indication: [REDACTED] Treatment with dapagliflozin for patients with symptomatic chronic HF and a reduced LVEF (HFrEF; LVEF ≤40%) has already been recommended by NICE (TA679; 2021).¹

Table 1: The decision problem

	Final scope issued by NICE	Decision problem addressed in the company submission	Rationale if different from the final NICE scope
Population	Adults with symptomatic chronic HF and an LVEF of 40% or more.	As per NICE final scope.	<p>The patient population of relevance to this submission is patients with symptomatic chronic HF and an LVEF >40%, hereafter referred to as "patients with HF and an LVEF >40%" for ease of reading.</p> <p>This patient population is covered under the anticipated changes to the marketing authorisation for dapagliflozin to cover [REDACTED] Treatment with dapagliflozin for patients with symptomatic chronic HFrEF (LVEF ≤40%) has already received positive guidance from NICE in TA679 (2021).¹</p> <p>Diagnosis of HF requires the presence of both cardiac dysfunction, as well as symptoms and signs of HF such as difficulty breathing, fatigue, ankle swelling, or oedema.^{2,3}</p>
Intervention	Dapagliflozin in combination with standard care (SoC) (including loop diuretics and symptomatic treatments for co-morbidities).	Dapagliflozin in addition to SoC (comprising loop diuretics, primarily furosemide or bumetanide).	<p>The intervention is aligned with the NICE final scope.</p> <p>Whilst patients with HF and an LVEF >40% may have multiple varying co-morbidities for which they are treated separately, SoC for symptom management of patients with HF and an LVEF >40% in UK clinical practice predominantly comprises treatment with loop diuretics (typically furosemide or bumetanide).⁴ Therefore, furosemide or bumetanide constitute the SoC in the economic analysis for this</p>

	Final scope issued by NICE	Decision problem addressed in the company submission	Rationale if different from the final NICE scope
			submission and the composition of SoC is assumed to be the same for both the intervention and the comparator.
Comparator(s)	Established clinical management without dapagliflozin, including but not limited to loop diuretics and symptomatic treatments for co-morbidities.	Placebo in addition to SoC (comprising loop diuretics, primarily furosemide or bumetanide).	The comparator is aligned with the NICE final scope. Within the economic analysis, placebo in addition to SoC is referred to as “SoC alone” for ease of reading.
Outcomes	The outcome measures to be considered include: <ul style="list-style-type: none"> • symptoms of HF; • hospitalisation for HF; • all-cause hospitalisation; • mortality; • cardiovascular mortality; • kidney function; • adverse effects of treatment; • health-related quality of life. 	As per the NICE final scope.	N/A.
Economic analysis	<ul style="list-style-type: none"> • The reference case stipulates that the cost effectiveness of treatments should be expressed in terms of incremental cost per quality-adjusted life year (QALY). • The reference case stipulates that the time horizon for estimating clinical and cost effectiveness should be sufficiently long to reflect any differences in costs or outcomes between the technologies being compared. • Costs will be considered from 	<ul style="list-style-type: none"> • The base case cost-effectiveness analysis expresses cost-effectiveness in terms of costs per QALYs gained, over a lifetime time horizon. • Costs are considered from an NHS and PSS perspective • No commercial discount is included for either the intervention or comparators. 	N/A.

	Final scope issued by NICE	Decision problem addressed in the company submission	Rationale if different from the final NICE scope
	<p>an National Health Service (NHS) and Personal Social Services (PSS) perspective.</p> <ul style="list-style-type: none"> The availability of any commercial arrangements for the intervention, comparator and subsequent treatment technologies will be taken into account. 		
Other considerations	<p>The availability and cost of biosimilar and generic products should be taken into account.</p> <p>Guidance will only be issued in accordance with the marketing authorisation. Where the wording of the therapeutic indication does not include specific treatment combinations, guidance will be issued only in the context of the evidence that has underpinned the marketing authorisation granted by the regulator.</p>	<p>The cost of generic products has been considered within the economic analysis as appropriate.</p> <p>The submission population is covered by the anticipated marketing authorisation for dapagliflozin.</p>	N/A.
Special considerations including issues related to equity or equality	<p>No special considerations relating to equity or equality are listed in the NICE final scope.</p>	<p>Equality issues related to the current use of dapagliflozin and limited access to secondary care for patients with HF and an LVEF >40%.</p>	<p>Dapagliflozin is currently available across both the primary and secondary care treatment settings for patients with HFrEF,¹ type 2 diabetes (T2DM),⁵⁻⁷ and chronic kidney disease (CKD).^{8,9} Initiation of dapagliflozin for the treatment of patients with HF and an LVEF >40% in the primary care setting would improve equality of access to dapagliflozin without relying on access to specialist care, which is limited to only a few HF centres commissioning services to support patients with HF and an LVEF >40% after diagnosis, or offering specialised HFpEF clinics alongside their usual HF services.¹⁰</p>

	Final scope issued by NICE	Decision problem addressed in the company submission	Rationale if different from the final NICE scope
			Given the substantial clinical experience in the prescribing of sodium-glucose co-transporter-2 (SGLT2) inhibitors in primary care, AstraZeneca firmly believes that there is no clinical rationale for specifically restricting access to dapagliflozin for patients with HF and an LVEF >40% by requiring specialist review before making the treatment recommendation. As in the case of HF _{rEF} , it is important to ensure that diagnosis of HF, including associated LVEF %, is clinically confirmed by a specialist, but once that diagnosis is known or if it is already determined, initiation of treatment with dapagliflozin should be in either primary or secondary care. This should be easily implementable given that most HF services are already organised across primary and secondary care and that dapagliflozin does not require up-titration nor specific monitoring over and above what is recommended for a patient with HF already. In addition, enabling the treatment of patients with dapagliflozin within primary care will support the NHS with its COVID-19 recovery plans by reducing both waiting times to outpatient services and unnecessary specialist referrals, minimising unwarranted variations in care for HF patients across England and Wales.

Abbreviations: CKD: chronic kidney disease; HF: heart failure; HF_{rEF}: HF with reduced ejection fraction; LVEF: left ventricular ejection fraction; NHS: National Health Service; NICE: National Institute for Health and Care Excellence; N/A: not applicable; PSS: Personal and Social Services; QALY: quality-adjusted life year; NYHA: New York Heart Association; SGLT2: sodium-glucose co-transporter-2; SoC: standard of care; T2DM: type 2 diabetes mellitus.

Source: Dapagliflozin NICE final scope [ID1648].¹¹

B.1.2. Description of the technology being evaluated

The draft summary of product characteristics (SmPC) for dapagliflozin that covers the indication of relevance to this submission (patients with HF and an LVEF >40%) is provided in Appendix C. Details of the technology being evaluated, including the method of administration, dosing and related costs, are provided in Table 2.

Table 2: Technology being evaluated

UK approved name and brand name	Dapagliflozin (Forxiga®).
Mechanism of action	<p>Dapagliflozin is a highly potent, selective and reversible inhibitor of SGLT2. Inhibition of SGLT2 receptors by dapagliflozin reduces reabsorption of glucose from the glomerular filtrate in the proximal renal tubule with a concomitant reduction in sodium reabsorption leading to urinary excretion of glucose and osmotic diuresis.</p> <p>However, the cardio-renal benefits of dapagliflozin are not solely dependent on the blood glucose-lowering effect and not limited to patients with diabetes. In addition to the osmotic diuretic and related hemodynamic actions of SGLT2 inhibition, there are potential secondary effects such as a reduction in volume overload, reduced blood pressure, and lower preload and afterload, which may have beneficial effects on cardiac remodelling and preserve renal function.⁸</p>
Marketing authorisation/CE mark status	Marketing authorisation for dapagliflozin in this indication is expected to be granted by the Medicines and Healthcare Products Regulatory Agency (MHRA) in [REDACTED] subject to no procedural delays.
Indications and any restriction(s) as described in the summary of product characteristics (SmPC)	<p>Indication of relevance to this submission:</p> <p>The anticipated marketing authorisation for dapagliflozin in this indication [REDACTED]</p> <p>Other indications:</p> <p>Dapagliflozin is also currently indicated for the:⁸</p> <ul style="list-style-type: none"> • Treatment of adults and children aged 10 years and above with insufficiently controlled T2DM as an adjunct to diet and exercise, either as a monotherapy when metformin is considered inappropriate due to intolerance or in addition to other medicinal products for treatment of T2DM; • Treatment of adults with symptomatic chronic HFrEF; • Treatment of adults with CKD. <p>Dapagliflozin has the following contraindications:⁸</p> <p>Hypersensitivity to the active substance or to any of the excipients.</p> <p>A full list of special warnings and precautions for use is provided in the current SmPC, available here: https://www.medicines.org.uk/emc/product/7607/smpc.</p>
Method of administration and dosage	10 mg oral dapagliflozin once daily.
Additional tests or investigations	No additional tests or investigations are required prior to the administration of dapagliflozin.

List price and average cost of a course of treatment	The list price of dapagliflozin is £36.59 per pack of 28 x 10 mg tablets. ^{12,13} The yearly cost of treatment with dapagliflozin is £477.30. ^a HF is a chronic condition, and therefore treatment with dapagliflozin is expected to be life-long or until there is a clinical reason to discontinue.
Patient access scheme (if applicable)	No patient access scheme is included as part of this appraisal.

^aCosting assumption: 365.25 days per year.

Abbreviations: CKD: chronic kidney disease; HF: heart failure; HFrEF: Heart failure with a reduced ejection fraction; LVEF: left ventricular ejection fraction; MHRA: Medicines and Healthcare Products Regulatory Agency; T2DM: type 2 diabetes mellitus; SGLT2: sodium-glucose transporter-2; SmPC: summary of product characteristics.

B.1.3. Health condition and position of the technology in the treatment pathway

B.1.3.1. HF overview

HF is a complex clinical syndrome that occurs when the heart is unable to pump enough blood to maintain a cardiac output that meets the metabolic needs of the body either at rest or on exertion, or without a rise in intracardiac pressure.² Diagnosis of HF requires the presence of both cardiac dysfunction, as well as symptoms and signs of HF such as difficulty breathing, fatigue, ankle swelling, or oedema.^{2, 3} Mortality associated with HF remains high, with approximately 50–75% of patients dying within 5 years of a HF diagnosis.¹⁴

Most commonly, HF is due to myocardial dysfunction, which may be systolic (reflecting contraction of the left ventricle of the heart), diastolic (reflecting relaxation and filling of the left ventricle of the heart), or both. However, valvular, pericardial or endocardial disease, as well as abnormalities of heart rhythm and conduction, can also cause or contribute to HF. The most common causes of myocardial dysfunction are ischaemic heart disease (IHD) and hypertension, although the cause in many patients is not known.¹⁵

Patients with HF often have other co-morbid conditions that may contribute to, or interact with, the severity of HF.¹⁶ In addition to CV-related co-morbidities such as hypertension, coronary artery disease (CAD), atrial fibrillation (AF) and CKD, other HF co-morbidities include chronic obstructive pulmonary disease (COPD) and T2DM.¹⁷⁻²⁰ Co-morbidities, such as CKD and T2DM have important clinical implications on patient outcomes and healthcare costs,^{15, 20-25} further accentuating the severity of disease burden with greater impact on mortality and morbidity.²⁶ A pooled analysis of studies with a follow-up of at least 6 months reported a 28% higher mortality risk in patients with HF and T2DM than patients with HF alone,²⁷ and over a 2-year period, a 12.4% decrease in survival was observed in patients with HF and CKD versus CKD alone.²⁸

HF is usually classified based on measurement of LVEF, obtained from echocardiography (or other imaging modalities). LVEF is a means of quantifying the percentage of blood in the left ventricle that is pumped out with every contraction.²⁹ Based on this measurement of LVEF, individuals with HF can be broadly classified into those with a preserved LVEF (HFpEF), those with a mildly reduced LVEF (HFmrEF), those with a reduced LVEF (HFrEF) and those with an improved LVEF (HFimpEF; Table 3):^{3, 15, 30}

- **HF_rEF**: Up to half of patients with HF have a reduced LVEF ≤40%.³ The underlying pathophysiology in these patients is systolic dysfunction.¹⁵ Dapagliflozin in this indication has already been recommended by NICE in TA679.¹
- **HF_{mr}EF**: Patients with HF and an LVEF between 41% and 49% are described as having HF with a mildly reduced LVEF, to reflect the fact that in most patients, pathophysiologically, HF_{mr}EF is more like HF_rEF than HF_pEF.³
- **HF_pEF**: Patients with signs and symptoms of HF, with raised natriuretic peptides and evidence of structural abnormalities such as elevated left ventricular filling pressure at rest or during exercise but an LVEF ≥50% are described as having HF_pEF.^{3, 15}
- **HF_{imp}EF**: Patients who had prior LVEF ≤40% with a follow-up measurement of LVEF >40%.³⁰

HF has historically been categorised as per the four phenotypes above based on LVEF, mainly due to multiple HF clinical trials initially demonstrating significant outcomes for treatments in patients with HF and an LVEF ≤40%. It is therefore important to note that the overall clinical syndrome of HF includes patients across the entire range of LVEF, which is a normally distributed variable.³

Moreover, while there are four HF classifications, there are in effect two clinically distinct patient populations with HF in UK clinical practice; those with LVEF ≤40% and those with LVEF >40%. This is predominantly due to the lack of disease-modifying treatment options for patients with HF and an LVEF >40%, coupled with the availability of disease-modifying treatment options for HF and an LVEF ≤40% that are routinely commissioned in UK clinical practice. Therefore, HF_{mr}EF and HF_pEF are not usually considered as clinically distinct subgroups for the purposes of treatment decisions. As outlined in the NICE final scope and in the decision problem for this appraisal (Table 1), this submission is concerned with the treatment of patients with HF and an LVEF >40%.

Table 3: Classifications of HF across major international HF guidelines

Type of HF	HFSA/HFA/ESC/JHFS 2021 Universal HF classification ³¹	ESC 2021 HF diagnosis criteria ³	2022 AHA/ACC/HFSA definitions ³⁰
HF _r EF	Symptoms ± signs ^a	Symptoms ± signs ^a	LVEF ≤40%
	LVEF ≤40%	LVEF ≤40%	
HF _{mr} EF	Symptoms ± signs ^a	Symptoms ± signs ^a	LVEF 41%–49%
	LVEF 41%–49% ^b	LVEF 41%–49% ^b	Evidence of spontaneous or provokable increased LV filling pressures ^d
HF _p EF	Symptoms ± signs ^a	Symptoms ± signs ^a	LVEF ≥50%
	LVEF ≥50%	LVEF ≥50%	
	Objective evidence of cardiac structural and/or functional abnormalities consistent with the presence of LV diastolic dysfunction/raised LV filling pressures, including raised natriuretic peptides ^c		Evidence of spontaneous or provokable increased LV filling pressures ^d
HF _{imp} EF	-	-	Previous LVEF ≤40% and a follow-up measurement of LVEF >40%

^aSigns may not be present in the early stages of HF (especially in HF_pEF) and in optimally treated patients; ^bFor

the diagnosis of HFmrEF, the presence of other evidence of structural heart disease (e.g., increased left atrial size, LV hypertrophy or echocardiographic measures of impaired LV filling) makes the diagnosis more likely; ^cFor the diagnosis of HFpEF, the greater the number of abnormalities present, the higher the likelihood of HFpEF; ^dFor example, elevated natriuretic peptide, non-invasive and invasive hemodynamic measurement.

Abbreviations: ACC: American College of Cardiology; AHA: American Heart Association; ESC: European Society of Cardiology; HF: heart failure; HFA: Heart Failure Association of the European Society of Cardiology; HFSA: heart failure Society of America; HFimpEF: heart failure with an improved ejection fraction; HFmrEF: heart failure with a mildly reduced ejection fraction; HFpEF: heart failure with a preserved ejection fraction; HFrEF: heart failure with a reduced ejection fraction; HFSA: Heart Failure Society of America; JHFS: Japanese Heart Failure Society; LV: left ventricular; LVEF: left ventricular ejection fraction.

B.1.3.2. Disease burden

Summary of disease burden

There are currently no disease-modifying treatments routinely commissioned in UK clinical practice for patients with HF and an LVEF >40%, highlighting the urgent unmet need for easily accessible new treatments which can reduce mortality and hospitalisation, and improve disease symptoms and quality of life for these patients

- **Mortality associated with HF is high;**¹⁴ following a hospitalisation for HF (HHF), the 5-year survival for patients with HFpEF is 35%, which is worse than many cancers.³²
- For patients with HF and an LVEF >40%, **the co-morbidity burden is substantial, and may contribute to, or interact with, patients' HF severity, which can greatly impact health-related quality of life (HRQoL).**^{16, 33-36} Co-morbidities of HF include CAD, AF, CKD, COPD and T2DM.¹⁷⁻²⁰
- Patients with HF and an LVEF >40% struggle with **poor HRQoL similar to, or worse than, patients with HFrEF.**³² For instance, physical activity levels for these patients have been reported to be as suppressed as those observed in patients with moderate-to-severe COPD.³⁷
- **HF and an LVEF >40% is associated with a considerable economic burden, primarily driven by high hospitalisation rates.**³⁸⁻⁴²
- **The prevalence of HF is likely to rise in the future,** due to factors such as the ageing population in the UK, and rising rates of obesity and T2DM.^{14, 43, 44}

HF represents one of the most significant healthcare problems in the UK; one in five people over 40 years old are at risk of developing HF in their lifetime.⁴⁵ While the mortality associated with HF remains high with up to 75% of patients dying within 5 years of diagnosis,¹⁴ for those with HF and an LVEF >40%, the 5-year survival rate following a HHF is 35%.³² Cardiovascular disease (CVD) is believed to cause a quarter of all deaths in the UK and has been identified by the NHS in its Long Term Plan as the single biggest area where lives can be saved until 2029.⁴⁶ To address this, the NHS has set the objective to better support people with HF in primary care through the provision of multi-disciplinary teams working across primary and secondary care.⁴⁶ Optimising treatment outcomes in HF will help meet this long-term NHS goal.

For patients with HF and an LVEF >40%, the co-morbidity burden is substantial, and may contribute to, or interact with, patients' HF severity, which can greatly impact HRQoL.^{16, 33-36} Many risk factors and co-morbidities can contribute to HF and an LVEF >40% including CAD, AF, CKD, COPD and T2DM.^{2, 29} There is a complex relationship between HF and its co-morbidities; HF may also cause common co-morbidities, which can then adversely affect overall

patient outcomes.⁴⁷ For instance, HF is a known risk factor for the development of incident co-morbidities such as CKD and T2DM,⁴⁷ both of which can negatively impact patient outcomes and healthcare costs,^{15, 20-25} further accentuating the severity of the HF disease burden.²⁶ As previously mentioned, there is a 28% higher mortality risk in patients with HF and T2DM than patients with HF alone, and a 12.4% decrease in survival over a 2-year period in patients with HF and CKD versus patients with CKD alone.^{27, 28} This emphasises the importance of managing co-morbidities in the treatment of HF.

The HRQoL of patients with HF and an LVEF >40% is poor, similar to, or worse than, patients with HFpEF.³² For instance, exercise intolerance is a hallmark feature in patients with HF and an LVEF >40%; cardiac and peripheral abnormalities as well as changes in body composition cause tissue congestion and disrupt oxygen delivery, resulting in exercise intolerance and physical inactivity.^{48, 49} Physical activity levels for patients with HF and an LVEF >40% have been reported to be as suppressed as those observed in patients with moderate-to-severe COPD.³⁷ Improving exercise capacity and HRQoL is therefore a primary goal in the management of patients with HF and an LVEF >40%.⁴⁸⁻⁵⁰

HF and an LVEF >40% is associated with a substantial economic burden, primarily driven by high rates of hospitalisations.³⁸⁻⁴² A systematic review of the economic burden associated with HFpEF (2001–2020) reported that hospitalisations account for approximately 80% of total costs associated with HFpEF treatment.⁵¹ HF is one of the leading causes of hospitalisations in people aged >65 years⁵² and of rehospitalisation in the general population.⁵³ Thus, HF is associated with a high economic burden and costs the NHS up to 2% of its annual budget (~£3 billion).^{43, 54} Reducing hospitalisations is therefore key to addressing the economic burden associated with HF. In addition to direct costs, HF also contributes substantial indirect costs as a result of mortality, lost productivity, and the need to provide long-term domiciliary or institutional care for some patients.⁵⁵

The prevalence of HF is likely to rise in the future, due to factors such as the ageing population in the UK, and rising rates of obesity and T2DM.^{14, 43, 44} Despite improvements in clinical care, many patients still experience disabling symptoms,^{56, 57} and mortality rates are expected to remain high.^{14, 57} Currently, there are no disease-modifying treatment options routinely commissioned by the NHS for patients with diagnosed HF and an LVEF >40% as, unlike HFpEF, several randomised controlled trials (RCTs) have failed to demonstrate improved outcomes in this patient population.⁵⁸ Thus, the current guideline on diagnosis and treatment of HF (NICE NG106) advises only on the treatment of underlying co-morbidities for patients with HF and an LVEF >40%, and to manage any congestion with diuretics.⁵⁹ There is consequently a substantial unmet need for easily accessible new treatments which can lower mortality, reduce hospitalisation rates, and improve symptoms and HRQoL for patients with HF and an LVEF >40%.

B.1.3.3. Epidemiology

The prevalence of HF is estimated to be 0.91% in England.⁶⁰ Therefore, based on 2021 population estimates,⁶¹ there are approximately 423,000 adult patients with HF in England and Wales.

As this submission is concerned with patients with HF and an LVEF >40% from both outpatient and inpatient (acute) settings, utilisation of data from the Clinical Practice Research Datalink (CPRD) dataset can be considered more representative of UK clinical practice to estimate the size of this patient population than the National HF Audit 2022 which focusses solely on the

acute setting.^{10, 57} The CPRD dataset includes patients with at least one relevant code for HF diagnosis in primary (SNOMED-CT) or secondary care (ICD-10) in the period of 1st January 2010 and 1st January 2020 in England.¹⁰ Of [redacted] eligible patients with HF and an LVEF recorded, approximately [redacted] patients ([redacted]) had a recorded LVEF >40%.⁶² Applying this proportion to the 423,000 adult patients with HF in England and Wales means that there are approximately [redacted] patients with HF and an LVEF >40% in primary or secondary care settings in England and Wales.

It should be noted that some UK prevalence estimates are as high as 900,000 patients with HF,⁶³ highlighting that the prevalence of HF based on the above data is likely underestimated. Also, although echocardiography is recommended by NICE for the diagnosis of HF, the measurement of LVEF has not always been recorded well in Read codes,⁶⁴ which constitutes a barrier to accurately assessing HF epidemiology in UK clinical practice.

B.1.3.4. Diagnosis of HF

The heterogenous nature of HF and an LVEF >40% (e.g., different contributing conditions), and the high frequency of co-morbidities, (e.g., CAD, AF, CKD, COPD and T2DM) that may mimic or accompany the condition, can make diagnosis challenging.^{2, 3} Current UK practice is consistent with the NICE HF guideline diagnostic pathway in England (NG106; Figure 1). Patients in whom there is clinical suspicion of HF receive a measurement of plasma N-terminal pro B-type natriuretic peptide (NT-proBNP). Where the NT-proBNP concentration is ≥ 400 ng/L, clinical assessment and transthoracic echocardiography should occur within 2 or 6 weeks to allow a diagnosis of HF to be established either by an HF specialist, or in some cases by a general practitioner (GP) following open access echocardiography.

Figure 1: Summary of NICE NG106 diagnostic pathway for HF

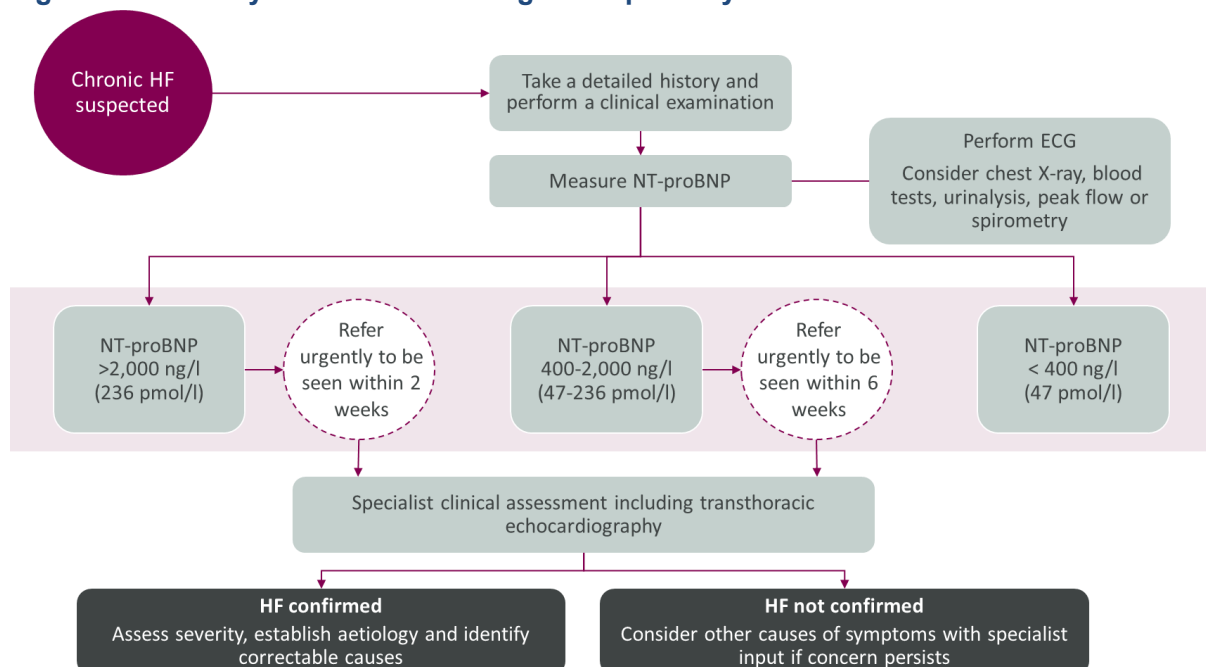

Source: Adapted from NICE NG106.⁵⁹

Abbreviations: ECG: echocardiogram; HF: heart failure; NT-proBNP: N-terminal pro B-type natriuretic peptide.

Clinical guidelines for the diagnosis of HF from the European Society of Cardiology (ESC), updated in 2022, have similar recommendations.³ Once a diagnosis of HF is confirmed, the

Company evidence submission template for dapagliflozin for treating chronic heart failure with preserved or mildly reduced ejection fraction [ID1648]

measurement of LVEF is used to further categorise the disease as either HFrEF (LVEF \leq 40%), HFmrEF (LVEF 41–49%) or HFpEF (LVEF \geq 50%).³ Whilst the diagnostic pathway is the same for all HF patients irrespective of LVEF, in practice (as in guidelines) once a patient’s LVEF has been determined, the therapeutic pathways diverge for HFrEF versus HFmrEF/HFpEF (though notably diuretics are common to both pathways). As previously mentioned, the management of patients with HF and an LVEF $>$ 40% is the same for both HFmrEF and HFpEF as no disease-modifying treatments are routinely commissioned in UK clinical practice for this patient population.

In UK clinical practice, HF symptom severity is routinely assessed using the New York Heart Association (NYHA) Functional Classification (Table 4), which is based on physical limitations due to symptoms. However, symptom severity does not correlate closely with LV function and patients with “mild symptoms” (NYHA class II) still have a substantial risk of hospitalisation and death.³ While the NYHA tool remains useful as a brief description of a patient’s clinical status, it is highly subjective with an inter-rater concordance of 54–56% for mild to moderate symptoms,⁶⁵ poorly reproducible, including among trained cardiologists,⁶⁶ and not patient-centric as it is a clinician’s assessment of a patients’ functional limitations.⁶⁵ Moreover, input from UK clinical experts indicates that NYHA class has a limited impact on the treatments offered to patients in clinical practice, given the subjective nature of the classification criteria.¹⁰

Table 4: NYHA classification criteria

NYHA stage	Criteria
I	No limitation of physical activity. Ordinary physical activity does not cause undue fatigue, palpitations, or dyspnoea.
II	Slight limitation of physical activity. The patient is comfortable at rest. Ordinary physical activity results in fatigue, palpitations, or dyspnoea.
III	Marked limitation of physical activity. The patient is comfortable at rest. Less than ordinary activity causes fatigue, palpitations, or dyspnoea.
IV	Inability to carry on any physical activity without discomfort. HF symptoms are present even at rest or with minimal exertion.

Abbreviations: HF: heart failure; NYHA: New York Heart Association.

The Kansas City Cardiomyopathy Questionnaire (KCCQ) has been demonstrated to be a reliable and valid patient-reported outcome measure to assess HRQoL in HFpEF,⁵⁰ and is considered to provide a more comprehensive and robust assessment of a patient’s health status and be more responsive to changes in health status than the NYHA classification.⁶⁷ The KCCQ score is composed of several domains such as physical limitations, symptoms, social limitations and QoL, as presented in Table 5.⁶⁷ Importantly, the KCCQ is a patient-reported outcome providing a more granular assessment of a patient’s symptoms and limitations. It is consequently a more robust measure of changes in a patient’s condition than NYHA class, particularly in clinical trials, and has established thresholds which indicate clinically relevant changes in health status.⁶⁸ Baseline KCCQ–Total Symptom Score (TSS) has been found to align with clinical outcomes, with patients with a worse KCCQ-TSS at baseline having higher mortality and higher rates of HHF.⁶⁸ As a result, KCCQ rather than NYHA class, has become the standard tool used in clinical trials to evaluate patient-reported health status and response to treatment in patients with HF.

Table 5: KCCQ questionnaire domains and summary scores

Domains	Description	TSS	CSS	OSS
Physical limitations	Q1: measures the limitations patients experience, due to their HF symptoms, in performing routine activities.	Score does not include this domain	Includes this domain	Includes this domain
Symptoms (frequency, severity and change over time)	Q2–9: quantifies the frequency and burden of clinical symptoms in heart failure, including fatigue, shortness of breath, paroxysmal nocturnal dyspnoea and patients' oedema/swelling	Includes the frequency and severity sub-domains	Includes this domain	Includes this domain
Self-efficacy and knowledge	Q11–12: quantifies patients' perceptions of how to prevent HF exacerbations and manage complications when they arise.	Score does not include this domain	Score does not include this domain	Score does not include this domain
QoL	Q13–15: quantifies patients' assessment of their quality of life, given the current status of their HF.	Score does not include this domain	Score does not include this domain	Includes this domain
Social interference	Q16: quantifies the extent to which HF symptoms impair patients' ability to interact in a number of social activities.	Score does not include this domain	Score does not include this domain	Includes this domain

Sources: Spertus *et al.* (2020);⁶⁹ FDA (2020).⁷⁰

Abbreviations: CSS: Clinical Summary Score; HF: heart failure; KCCQ: Kansas City Cardiomyopathy Questionnaire; OSS: Overall Summary Score; QoL: quality of life; TSS: Total Symptom Score.

B.1.3.5. Current management of patients with HF and an LVEF >40%

As per NICE NG106, recommendations for pharmacological treatments in HF are stratified between HF_rEF and HF_pEF in UK clinical practice (Figure 2).⁵⁹ In this context, as the management of patients with HF and an LVEF >40% is the same for both HF_mrEF and HF_pEF, it is assumed that recommendations in this clinical guideline for the HF_pEF population comprise both subpopulations i.e., patients with HF and an LVEF >40%.

Once the diagnosis of HF and an LVEF >40% has been confirmed on the basis of clinical assessment, natriuretic peptides and echocardiography, patients are typically offered loop diuretics for congestive symptoms and fluid retention, in addition to treatments for any co-morbidities.⁵⁹ While patients with HF and an LVEF >40% may have multiple varying co-morbidities for which they are separately treated, SoC for symptom management of HF and an LVEF >40% in UK clinical practice predominantly comprises treatment with loop diuretics (typically furosemide or bumetanide).⁴ In addition, unless the condition is unstable, a personalised exercise cardiac rehabilitation programme is to be offered, though uptake of this is typically poor.⁵⁹ For those whose HF does not respond to this treatment, further specialist advice is needed.⁵⁹

Figure 2: Summary of pharmacologic treatments for patients with HF and an LVEF >40% recommended in NG106

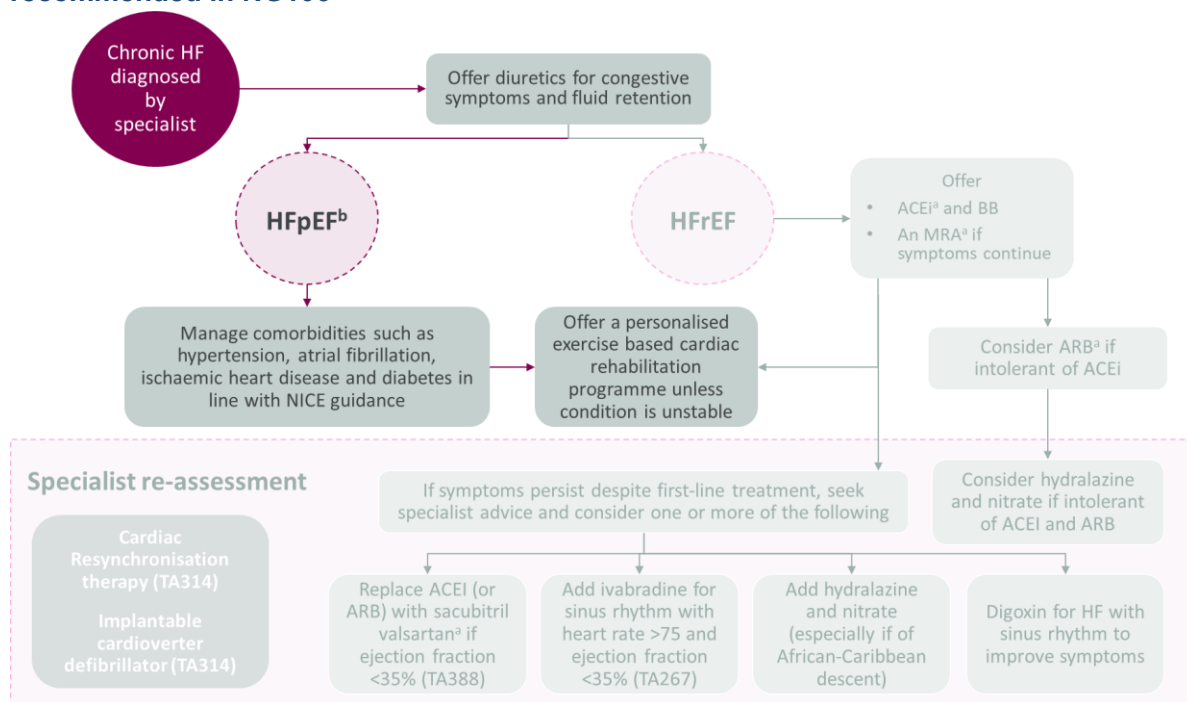

^aMeasure serum sodium, potassium and assess renal function before and after starting and after each dose increment. If eGFR is 30 to 45 ml/min/1.73 m², consider lower doses or slower titration of ACEi or ARBs, MRAs, sacubitril valsartan and digoxin. ^bIt is assumed that recommendations for the HFpEF population comprise both the HFpEF and HFmrEF populations; i.e., those with HF and an LVEF >40%.

Source: Adapted from NICE NG106.⁵⁹

Abbreviations: ACEi: angiotensin-converting enzyme inhibitor; ARB: angiotensin-receptor blocker; BB: beta-blocker; HF: heart failure; eGFR: estimated glomerular filtration rate; HFpEF: heart failure with a preserved ejection fraction; HFmrEF: heart failure with a mildly reduced ejection fraction; MRA: mineralocorticoid-receptor antagonist; TA: technology assessment.

B.1.3.6. Diagnosis and management of patients with HF in clinical practice

There are three main routes through which patients are diagnosed with HF and an LVEF >40% in the UK: by a specialist using echocardiography following GP referral due to raised NT-proBNP and HF symptoms (as per the NICE pathway), in general practice following NT-proBNP tests using open access echocardiography or following an emergency admission to hospital for an acute HF event.

Under the NICE diagnosis pathway, once HF symptoms are recognised and clinical suspicion of HF is raised, the patient is referred by their GP for further HF diagnostic tests, specifically echocardiography, performed by an HF specialist. As few as 24% of patients with recorded HF symptoms follow the NICE pathway to diagnosis, with only 4% completing the NICE pathway within its 6-week timeframe.⁶⁴ In an observational study using CPRD data between 2010 and 2013, from presenting with symptoms suggestive of HF in primary care to recorded relevant investigations either as an echocardiogram or NT-pro-BNP test, a median time of 9.5 months (292 days) was observed, and for a referral to a specialist, a median time of 7.7 months (236 days) was observed, substantially exceeding the NICE recommended timelines of 2–6 weeks.⁷¹

Alternatively, in some cases patients are referred by their GP for diagnostic tests performed in primary care through open access echocardiography. There are some limitations to this approach owing to variable expertise amongst GPs in interpreting the results for patients with HF and an LVEF >40%. Several other important parameters need to be measured and correctly

Company evidence submission template for dapagliflozin for treating chronic heart failure with preserved or mildly reduced ejection fraction [ID1648]

interpreted, including the presence of both cardiac dysfunction, as well as symptoms and signs of HF such as difficulty breathing, fatigue, ankle swelling, or oedema.^{2,3} There is the potential for misdiagnosis or HF misclassification with open access echocardiography, with particular risk that patients with hypertension and other comorbidities may be wrongly classified as having HF and an LVEF >40%.¹⁰ This highlights the specialist-confirmed HF diagnosis following echocardiogram as per the NICE clinical pathway.

In UK clinical practice, the majority of patients (approximately 80%) only receive a formal diagnosis of HF following hospitalisation for acute decompensated HF.⁶⁴ According to UK clinical experts consulted by AstraZeneca, many of these patients would typically have been known to primary care as having suspected HF symptoms but are only formally coded as having HF following an acute admission. These patients, once diagnosed, tend to be quickly discharged back to primary care where they are then managed for chronic HF symptoms.

As well as incident cases, there are prevalent populations of patients already diagnosed with HF and an LVEF >40% through one of the three pathways outlined above that are predominantly managed in primary care due to a lack of specific HF services actively managing this population. Input from UK clinical experts indicates that limited resource availability (e.g., HF nurses, cardiologists) contributes to inequalities in patient access to relevant investigations and HF services in the UK.¹⁰ Moreover, the measurement of LVEF has not always been recorded well in Read Codes, which constitutes a further barrier to effective management of the condition where early identification and classification of HF are key to avoid delays that can negatively impact morbidity and mortality.^{72,64}

Once a diagnosis of HF and an LVEF >40% has been established, loop diuretics for congestive symptoms and fluid retention, namely furosemide and bumetanide, as well as treatments for co-morbidities are to be offered according to NG106.^{4,59} For instance, in a contemporary, cross-sectional study of patients with HFpEF in primary care, 80% were hypertensive, thus received treatment for this co-morbidity.⁷³ The majority of patients with HF and an LVEF >40% are managed in primary care and are either not referred to specialists or, if referred, are not provided with a treatment plan upon discharge.^{73,74,75} Inputs from UK clinical experts indicate that, in UK clinical practice, only a few HF centres commission services to support patients with HF and an LVEF >40% after diagnosis, or offer specialised HFpEF clinics alongside their usual HF services, owing predominantly to the lack of therapeutic options available to this patient population to date.¹⁰

For all patients with HF and stable disease, a personalised exercise cardiac rehabilitation programme should be offered according to NG106,⁵⁹ which has been shown to improve outcomes after one year. However, in UK clinical practice few patients are referred, with just 12% of patients with HF referred for cardiac rehabilitation following a HHF in the 2022 National HF Audit.⁵⁷ This is due mainly to capacity challenges and the design of services being unsuitable for frail patients.¹⁰

In summary, patients diagnosed with HF and an LVEF >40% are predominantly managed by primary care physicians with a focus on HF symptom control to relieve congestion and oedema and managing common co-morbidities such as hypertension.¹⁰ NG106 states that monitoring in primary care, including clinical assessment, renal assessment and medication review, should be individualised with a frequency based on co-morbidities, prescribed medications and clinical stability, but that this should be at least six-monthly.⁵⁴ Primary care physicians already have considerable clinical experience in the prescribing of dapagliflozin and could therefore initiate

treatment at the earliest opportunity for patients with new and existing diagnoses, or as part of routine check-up appointments in situations where there is insufficient capacity to proactively schedule a therapy review appointment. Although the availability of novel therapies for patients with HF and an LVEF >40% may result in a greater focus on specialist service provision, service re-design specifically for the prescribing of dapagliflozin in these patients would not be necessary as dapagliflozin does not require dose up-titration nor specific monitoring over and above what is already recommended for a patient with HF.

B.1.3.7. Proposed positioning of dapagliflozin in the treatment pathway for patients with HF and an LVEF >40%

In the pivotal DELIVER RCT, dapagliflozin administered in addition to SoC demonstrated a significant reduction in the primary composite endpoint of CV mortality and HF events (HHF or an urgent HF visit [UHFV] requiring IV diuretic therapy, hereafter jointly referred to as HF events for ease of reading) compared with placebo in addition to SoC (see Section B.2.6), along with a favourable safety profile and significant symptom benefit as measured by the KCCQ-TSS.⁷⁶ SoC consisted of the treatments recommended in NICE NG106, namely diuretics for decongestion and the management of co-morbidities.⁵⁹

Positioning

The proposed positioning of dapagliflozin is in patients with a diagnosis of HF and an LVEF >40% confirmed by a specialist, as an add-on to current SoC, which predominantly comprises loop diuretics as illustrated in Figure 3 as part of the existing NICE NG106 treatment pathway.

This proposed positioning is based on UK clinical expert input and the clinical benefit demonstrated with dapagliflozin in addition to SoC at this place in the pathway in the DELIVER trial.^{10, 76} Given the absence of disease-modifying treatment options in patients with HF and an LVEF >40%, dapagliflozin should be initiated as soon as the diagnosis is established, and irrespective of diuretic initiation depending on the specific signs of congestion. For patients with a documented diagnosis of HF and an LVEF >40% that are already managed in primary care (or those not routinely followed-up within specialist care), dapagliflozin could be initiated at the earliest opportunity, ideally following proactive invitation for a treatment optimisation review or alternatively, where capacity is a limitation, during their routine check-up appointment without the need for a specific or extended appointment. Having the HF diagnosis confirmed by a specialist mitigates the risk of potential misdiagnosis following misinterpretation of open access echocardiography and therefore removes the risk of over-treatment in patients with conditions that can mimic HF and an LVEF >40%.

In the context of the existing NICE clinical pathway adapted in the figure below, 'HFpEF' encompasses all patients with HF and an LVEF >40% for which clinical management and treatment are the same.

Figure 3: Current treatment pathway for patients with HF and an LVEF >40% in NG106 and proposed positioning of dapagliflozin

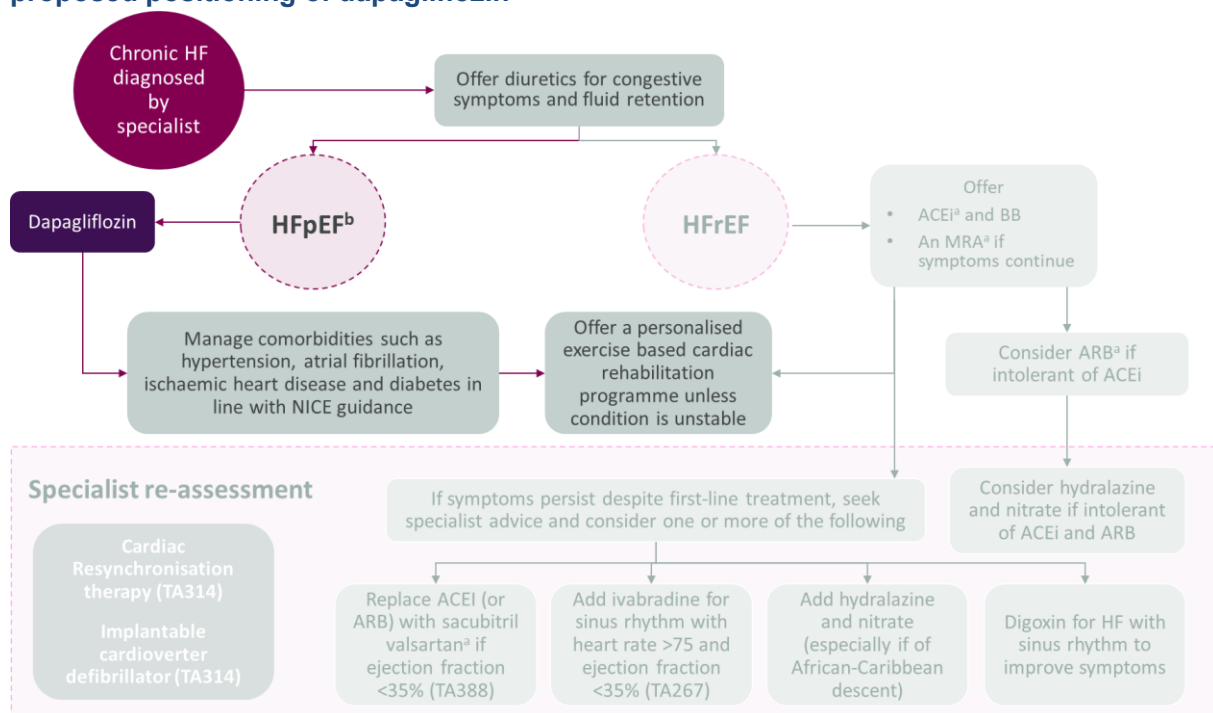

^aMeasure serum sodium, potassium and assess renal function before and after starting and after each dose increment. If eGFR is 30 to 45 ml/min/1.73 m², consider lower doses or slower titration of ACEi or ARBs, MRAs, sacubitril valsartan and digoxin. ^bIt is assumed for the appraisal that recommendations for the HFpEF population comprise both the HFpEF and HFmrEF populations; those with HF and an LVEF >40%.

Source: Adapted from NICE NG106.⁵⁹

Abbreviations: ACEi: angiotensin-converting enzyme inhibitor; ARB: angiotensin-receptor blocker; BB: beta-blocker. HF: heart failure; eGFR: estimated glomerular filtration rate; HFpEF: heart failure with a preserved ejection fraction; HFmrEF: heart failure with a mildly reduced ejection fraction; MRA: mineralocorticoid-receptor antagonist; TA: technology assessment.

Comparators

As per NICE NG106 and clinical practice, the relevant comparator for dapagliflozin for the treatment of patients with HF and an LVEF >40% is placebo in addition to SoC (i.e., SoC alone). While patients with HF and an LVEF >40% may have varying multiple co-morbidities for which they are separately treated, due to the lack of disease-modifying treatment options routinely commissioned in UK clinical practice in this indication, SoC for these patients consists of loop diuretics for congestive symptoms and fluid retention.⁵⁹ The loop diuretics considered as SoC in UK clinical practice for the management of patients with HF and an LVEF >40% are furosemide and bumetanide.⁴ While dapagliflozin is expected to be used in addition to SoC, including loop diuretics, other treatments are very much dependent on a patients' underlying symptoms and co-morbidities.

Treatment setting

As per TA679,¹ initiation of dapagliflozin in patients with HFrEF should be on the advice of a HF specialist, while monitoring is to be done by the most appropriate healthcare professional. It is proposed that treatment with dapagliflozin in patients with HF and an LVEF >40% could be initiated either in primary or secondary care, with confirmation of HF diagnosis by a specialist enabling the initiation of dapagliflozin in primary care without the need for further specialist advice. Given that patients may be discharged back to primary care following specialist diagnosis before a care plan is provided or treatment is initiated, it is both appropriate and optimal for the

patient that primary care physicians are able to initiate therapy autonomously. This is also critical to ensure that the management of patients already diagnosed with HF and an LVEF >40% who are managed in primary care is optimised, allowing dapagliflozin to be initiated at the earliest opportunity, ideally following proactive invitation for a treatment optimisation review or alternatively, where capacity is a limitation, during their routine check-up appointment without the need for a specific or extended appointment. In the case of both an incident and prevalent population with confirmed HF and an LVEF >40%, the requirement to seek additional specialist advice before treatment initiation would delay access and create additional resource constraints in both primary and secondary care amidst the large post-COVID back-logs still being experienced. As dapagliflozin is currently available across the primary and secondary care treatment settings for patients with T2DM,⁵⁻⁷ CKD,⁹ including those with co-morbid HF and an LVEF >40%, and HFrEF,¹ clinicians across care settings have considerable clinical experience with prescribing dapagliflozin. Therefore, the additional advice of a HF specialist seems unnecessary for the initiation of dapagliflozin after HF and an LVEF >40% has already been diagnosed, and delays could be costly in terms of morbidity and mortality.⁷²

Finally, it should be noted that based on feedback from UK clinical experts consulted by AstraZeneca, the recommendation made by NICE in TA679 that dapagliflozin can be initiated to treat patients with HFrEF following the “advice of a HF specialist”,¹ has commonly been misinterpreted in UK clinical practice to be the same as “initiated by a specialist”, requiring an additional referral back to specialist services prior to the initiation of treatment. Misinterpretation of the NICE TA679 recommendation constitutes an additional barrier to access for many patients with HFrEF which AstraZeneca believes to contradict the intentions of the recommendations in TA679. This is especially worrisome considering the current post-COVID back-log for specialist review with estimates of over 275,000 people waiting for heart tests and treatment in September 2021 in England.⁷⁷ Therefore, empowering primary care physicians to initiate treatment with dapagliflozin after the appropriate diagnostic work-up is complete in patients with HF and an LVEF >40% is key to overcoming the barriers in access to care for these patients, including the inequalities associated with different levels of specialist provision across the country, as discussed below.

B.1.4. Equality considerations

Based on insights gathered by AstraZeneca in discussions with UK healthcare professionals, very few specialist centres review or actively manage patients with HF and an LVEF >40%. Most patients are managed in the primary care setting and, in some areas, there are no specialist-led or multidisciplinary clinics organised or commissioned to manage these patients.¹⁰ Access to specialist care is even further restricted by the current post-COVID back-log.⁷⁷ Moreover, as dapagliflozin is already routinely commissioned and represents established clinical practice for treating T2DM,⁵⁻⁷ CKD,⁹ and HFrEF,¹ clinicians across both the primary and secondary care settings have considerable clinical experience in the prescribing of dapagliflozin. Therefore, enabling the initiation of dapagliflozin in both primary and secondary care for the treatment of patients with HF and a documented LVEF >40% would ensure consistent equality of access to efficacious therapies without relying on specialist care, which may not exist or have long waiting lists in some areas of the UK, and therefore would otherwise serve to drive unwarranted variation in care.

B.2. Clinical effectiveness

Summary of clinical effectiveness

- DELIVER was an international, multicentre, parallel-group, event-driven, double-blind RCT with a median follow-up of ■ months which enrolled 6,263 patients and compared dapagliflozin (n=3,131) with placebo (n=3,132) for the treatment of patients with HF and an LVEF >40%, in addition to SoC.^{76, 78}
- DELIVER is the first clinical trial in a patient population with HF and an LVEF >40% to include patients with improved LVEF (HFimpEF; prior LVEF ≤40% with improvement to >40% before study enrolment; ■ of the full analysis set [FAS] population).^{76, 79}
- Dapagliflozin in addition to SoC (referred to as dapagliflozin throughout Section B.2 for simplicity) was significantly superior to placebo in addition to SoC (referred to as placebo throughout Section B.2 for simplicity) in reducing the incidence of the primary composite endpoint of CV mortality or a HF event (hazard ratio [HR] 0.82; 95% confidence interval [CI]: 0.73, 0.92; p<0.001).⁷⁶
- Pre-planned subgroup analysis of the primary efficacy outcomes was consistent across the prespecified subgroups, including those defined according to LVEF, with no attenuation in the highest LVEF group:⁷⁶
 - Results were consistent across all LVEF groups: ≤49% (HR 0.87, 95% CI: 0.72, 1.04), 50–59% (HR 0.79, 95% CI: 0.65, 0.97), ≥60% (HR 0.78, 95% CI: 0.62, 0.98) (p-value for interaction=■).^{76,78}
 - Patients with HFimpEF experienced similar treatment benefits compared to those with HF and an LVEF consistently >40% (HR 0.74; 95% CI: 0.56, 0.97 versus HR 0.84; 95% CI: 0.73, 0.95; p-value for interaction=■).^{76, 79}
- Dapagliflozin was also superior to placebo in reducing the risk of the secondary composite endpoint of CV mortality and recurrent HF events (rate ratio [RR] 0.77; 95% CI: 0.67, 0.89; p<0.001), and in reducing recurrent HF events (RR 0.73; 95% CI: 0.62, 0.87; p=0.0003).^{76, 78}
- Both CV and all-cause mortality were reduced in patients treated with dapagliflozin compared with placebo although the differences were not statistically significant (HR 0.88; 95% CI: 0.74, 1.05; p=0.1678 and HR 0.94; 95% CI: 0.83, 1.07; p=0.3425, respectively).^{76,78}
- Dapagliflozin provided statistically significant improvements in symptom and physical function benefit as measured by KCCQ-TSS, -PLS, -CSS and -OSS at 8 months (mean difference in change from baseline 2.4,⁷⁶ 1.9, 2.3 and 2.1 points higher versus placebo; p<0.001, for all).⁷⁹
- Based on UK clinical expert feedback, the baseline characteristics and background therapy profiles of the patients enrolled in the DELIVER trial were considered overall generalisable to those seen in UK clinical practice.¹⁰

B.2.1. Identification and selection of relevant studies

A systematic literature review (SLR) was conducted to identify relevant evidence of the clinical

Company evidence submission template for dapagliflozin for treating chronic heart failure with preserved or mildly reduced ejection fraction [ID1648]

efficacy and safety of treatments for patients with HF and an LVEF >40% in the form of RCTs.

The SLR was broad, and considered a range of possible treatments for patients with HF and an LVEF >40%, including SGLT2 inhibitors as well as loop diuretics, angiotensin-converting enzyme inhibitors (ACEi), angiotensin II receptor blockers (ARBs) and beta blockers. However, as described in B.1.1, placebo in addition to SoC represents the only comparator to dapagliflozin in this appraisal, and in UK clinical practice SoC comprises predominantly loop diuretics (e.g., furosemide or bumetanide). As such, only included studies conducted in patients receiving either dapagliflozin or loop diuretics were ultimately extracted for this submission, in line with the decision problem of this appraisal (see Appendix D).

The SLR was originally conducted in August 2018 and a subsequent update was conducted in June 2022, with adaptations made to the original SLR protocol to ensure alignment of the SLR with the decision problem of this appraisal. For instance, the original SLR considered studies in patients with HFrEF as well as observational study designs, which are not relevant to this submission.

In total, across the original SLR and the SLR update, 258 publications reporting 36 unique studies were included in the SLR. Of the 36 unique studies, 4 studies were identified in patients with HF and an LVEF >40% receiving either dapagliflozin or loop diuretics:

Two studies were identified that investigated dapagliflozin:

- DELIVER⁸⁰
- PRESERVED-HF⁸¹

Two studies were identified that investigated loop diuretics:

- DROP-PIP⁸²
- J-MELODIC⁸³

The trials identified for dapagliflozin are discussed in more detail in B.2.2 below. The two studies investigating loop diuretics were not considered to provide more relevant evidence for SoC in comparison to the DELIVER trial (see Appendix D.4), and therefore are not considered further in this submission.

Full details on the SLR, including the detailed search terms, inclusion/exclusion criteria and a Preferred Reporting Items for Systematic Reviews and Meta-Analyses (PRISMA) flow diagram detailing studies that were included and excluded at each stage of screening can be found in Appendix D.

B.2.2. List of relevant clinical effectiveness evidence

Two studies investigating the efficacy of dapagliflozin in patients with HF and an LVEF >40% were identified in the clinical SLR: DELIVER (N=6,263) and PRESERVED-HF (N=324).^{76, 81} Of these, the clinical trial most relevant to this submission is DELIVER, the pivotal international, multicentre, parallel-group, event-driven, double-blind RCT for dapagliflozin in this indication that compared treatment with dapagliflozin in addition to SoC versus placebo in addition to SoC in patients with HF and an LVEF >40%.⁷⁶

PRESERVED-HF is a smaller clinical trial that evaluated whether dapagliflozin in addition to SoC improved symptoms and physical limitations versus placebo in addition to SoC, as measured by

Company evidence submission template for dapagliflozin for treating chronic heart failure with preserved or mildly reduced ejection fraction [ID1648]

the KCCQ-CSS.⁸¹ PRESERVED-HF was not used to populate the economic model for this submission due to its smaller sample size of 324 patients aged ≥ 19 with HF and an LVEF $\geq 45\%$ (which differs from the population included in the DELIVER trial), its short duration of 12 weeks, and as it primarily evaluated HF disease-specific health status.⁸¹ The results of this study support that dapagliflozin significantly improved patient-reported symptoms and physical limitations of patients with HF and an LVEF $\geq 45\%$ compared with placebo, and was generally well tolerated.⁸¹ Further details of the PRESERVED-HF trial are presented in B.2.11 for completeness. A brief summary of both trials is presented in Table 6.

Table 6: Clinical effectiveness evidence

Study	DELIVER ^{76, 78}	PRESERVED-HF ^{81, 84}
Study design	International, multicentre, parallel-group, event-driven, randomised, double-blind, placebo-controlled Phase III study.	Randomised, double-blind, placebo-controlled, multicentre Phase IV study.
Population	Patients aged ≥ 40 years with NYHA functional class $\geq II$ with LVEF $>40\%$ and evidence of structural heart disease.	Patients aged ≥ 19 years with NYHA functional class $\geq II$ with LVEF $\geq 45\%$.
Intervention(s)	Dapagliflozin 10 mg once daily in addition to SoC (N=3,131) <i>referred to as dapagliflozin throughout Section B.2 for simplicity.</i>	Dapagliflozin 10 mg once daily in addition to SoC (N=162) <i>referred to as dapagliflozin throughout Section B.2 for simplicity.</i>
Comparator(s)	Placebo in addition to SoC (N=3,132) <i>referred to as placebo throughout Section B.2 for simplicity.</i>	Placebo in addition to SoC (N=162) <i>referred to as placebo throughout Section B.2 for simplicity.</i>
Indicate if study supports application for marketing authorisation	Yes.	No.
Indicate if study used in the economic model	Yes.	No.
Rationale if study not used in model	Pivotal clinical efficacy and safety trial reporting outcomes relevant to the economic model.	PRESERVED-HF was conducted in a smaller population aged ≥ 19 years, exclusively patients with HF and an LVEF $\geq 45\%$, and primarily evaluated HF disease-specific health status. As such, PRESERVED-HF does not represent the primary source of efficacy and safety data in this indication, as outlined above.
Reported outcomes specified in the decision problem	<ul style="list-style-type: none"> • Time to first occurrence of any of the components of this composite: <ul style="list-style-type: none"> ○ CV mortality; ○ HHF; ○ UHFV (e.g., emergency department or outpatients visit). • Total number of HF events 	<ul style="list-style-type: none"> • Change from baseline in HF related health status using the KCCQ- CSS at 12 weeks; • Change from baseline in HF related health status using the KCCQ-OSS at 12 weeks; • Change from baseline in NT-proBNP at 6 and 12 weeks; • Change from baseline in BNP at

Study	DELIVER ^{76, 78}	PRESERVED-HF ^{81, 84}
	<p>(first and recurrent) and CV mortality;</p> <ul style="list-style-type: none"> • Change from baseline in the TSS of the KCCQ at 8 months; • Time to the occurrence of CV death; • Time to the occurrence of death from any cause; • Safety objective: serious adverse events (SAEs), adverse events leading to treatment discontinuation (DAEs), amputations, adverse events (AEs) leading to amputation and potential risk factor AEs for amputations affecting lower limbs; • Time to first occurrence of hospitalisation from any cause; • Proportion of patients with worsened NYHA class from baseline to 8 months; • EQ-5D-5L; • Change in CSS, TSS subscores, OSS, QoL score of the KCCQ; • Change in eGFR from baseline. <p><i>Outcomes incorporated into the model marked in bold.</i></p>	<p>6 and 12 weeks;</p> <ul style="list-style-type: none"> • Change from baseline in 6-minute walk test at 12 weeks; • Proportion of patients with a ≥ 5pts increase in KCCQ-CSS and KCCQ-OSS at 12 weeks; • Proportion of patients with a $\geq 20\%$ decrease in NT-proBNP at 6 and 12 weeks; • Proportion of patients with a ≥ 5pts increase in KCCQ and a $\geq 20\%$ decrease in NT-proBNP at 6 and 12 weeks; • Composite mean hierarchical-rank clinical score between dapagliflozin versus placebo. All patients will receive a global rank endpoint based on time to death (tier 1) time to HHF or UHFV (tier 2) or change in KCCQ-CSS from baseline to 12 weeks; • Number of HHF; • Number of UHFV; • Number of HHF and UHFV; • Change in NYHA Class at 6 and 12 weeks; • Change from baseline in left atrial volume index and other measures of left ventricular diastolic function; • Safety variables: all-cause mortality, CV mortality, non-fatal MI, stroke, AKI, AEs, SAEs.
<p>All other reported outcomes</p>	<ul style="list-style-type: none"> • Change in systolic BP from baseline; • Change in body weight from baseline. <p><i>Outcomes incorporated into the model marked in bold.</i></p>	<ul style="list-style-type: none"> • Change from baseline in HbA1c over the treatment period; • Change in weight at 6 and 12 weeks; • Change in systolic blood pressure at 6 and 12 weeks; • Proportion of patients that progress to diabetes during the treatment period; • Change from baseline in average weekly loop diuretic dose.

Source: DELIVER CSR;⁷⁸ Solomon *et al.* (2022);⁷⁶ Solomon *et al.* (2022) – Supplementary Appendix.⁸⁵ Nassif *et al.* (2021);⁸¹ ClinicalTrials.gov 2021 [NCT03030235].⁸⁴

Abbreviations: AE: adverse event; AKI: acute kidney injury; BP: blood pressure; CSS: Clinical Summary Score; CV: cardiovascular; DAE: adverse events leading to treatment discontinuation; eGFR: estimated glomerular filtration rate; EQ-5D-5L: EuroQol-5 Dimensions-5 Levels; HbA1c: haemoglobin A1c; HF: Heart failure; HHF: hospitalisation for heart failure; HFrEF: Heart failure with a reduced ejection fraction; KCCQ: Kansas City Cardiomyopathy Questionnaire; LVEF: left ventricular ejection fraction; MI: myocardial infarction; NT-proBNP: N-terminal pro B-type natriuretic peptide; NYHA: New York Heart Association; OSS: Overall Summary Score; QoL: quality of life; SAE: serious adverse event; TSS: Total Symptom Score; UHFV: urgent heart failure visit.

B.2.3. Summary of methodology of the relevant clinical effectiveness evidence

B.2.3.1. Summary of trial methodology

DELIVER was an international, multicentre, parallel-group, event-driven, randomised, double-blind Phase III study in patients with HF and an LVEF >40% and evidence of structural heart disease, evaluating the effect of dapagliflozin 10 mg versus placebo, given once daily in addition to background regional SoC therapy, including treatments for co-morbidities, in reducing the composite of CV mortality and HF events over a 28-month median follow-up period.⁷⁶ The methodology of DELIVER is summarised in Table 7 and Figure 4.

Table 7: Summary of trial methodology: DELIVER

Parameter	Description
Study objective	To determine whether dapagliflozin is superior to placebo, in addition to SoC, in reducing the composite of CV mortality and HF events in patients with HF and an LVEF >40%.
Trial design	International, multicentre, parallel-group, event-driven, randomised, double-blind Phase III trial.
Duration of study	DELIVER was event-driven with an anticipated duration of 39 months. The median time in study until primary analysis censoring date (PACD) was ■■■ months (range ■■■ to ■■■ months).
Method of randomisation	Fixed-randomisation schedule using balanced blocks and interactive voice- or web-response system.
Method of blinding (care provider, patient and outcome assessor)	Patients, investigators, and adjudication committee were blind to the assignment of treatment. The data monitoring committee (DMC) had access to the individual treatment codes and was able to merge these with the collected study data while the study was ongoing. A DMC charter was prepared to detail precise roles and responsibilities and procedures to ensure maintenance of the blinding and integrity of the study in the review of accumulating data and interactions with the executive committee (EC). The EC was comprised of designated international academic leaders and nonvoting members of AstraZeneca, and operated under an EC charter.
Eligibility criteria for participants	<p>Inclusion criteria:</p> <ol style="list-style-type: none"> 1. Provision of signed informed consent prior to any study specific procedures. 2. Male or female patients age ≥40 years. 3. Documented diagnosis of symptomatic HF (NYHA class II-IV) at enrolment, and a medical history of typical symptoms/signs^a of HF ≥6 weeks before enrolment with at least intermittent need for diuretic treatment. 4. LVEF >40% and evidence of structural heart disease (i.e., left ventricular hypertrophy or left atrial enlargement^b) documented by the most recent echocardiogram, and/or cardiac MR within the last 12 months prior to enrolment. For patients with prior acute cardiac events or procedures that may reduce LVEF, e.g., as defined in exclusion criterion 6, qualifying cardiac imaging assessment at least 12 weeks following the procedure/event is required 5. NT-pro BNP ≥300 pg/ml at Visit 1 for patients without ongoing atrial fibrillation/flutter. If ongoing atrial fibrillation/flutter at Visit 1, NT-pro BNP must be ≥600 pg/mL.

Parameter	Description
	<p data-bbox="539 237 1385 331">6. Patients may be ambulatory, or hospitalised; patients must be off intravenous heart failure therapy (including diuretics) for at least 12 hours prior to enrolment and 24 hours prior to randomisation.</p> <p data-bbox="491 365 699 394">Exclusion criteria</p> <ol data-bbox="539 405 1385 2011" style="list-style-type: none"> 1. Receiving therapy with an SGLT2 inhibitor within 4 weeks prior to randomisation or previous intolerance to an SGLT2 inhibitor. 2. Type 1 diabetes mellitus. 3. eGFR <25 mL/min/1.73 m² (CKD-EPI formula) at Visit 1. 4. SBP<95 mmHg on 2 consecutive measurements at 5-minute intervals, at Visit 1 or at Visit 2. 5. SBP≥160 mmHg if not on treatment with ≥3 blood pressure lowering medications or ≥180 mmHg irrespective of treatments, on 2 consecutive measurements at 5-minute intervals, at Visit 1 or at Visit 2. 6. MI, unstable angina, coronary revascularisation (PCI or CABG), ablation of atrial flutter/fibrillation, valve repair/replacement within 12 weeks prior to enrolment. Before enrolment, these patients must have their qualifying echocardiography and/or cardiac MRI examination at least 12 weeks after the event. 7. Planned coronary revascularisation, ablation of atrial flutter/fibrillation and valve repair/replacement. 8. Stroke or TIA within 12 weeks prior to enrolment. 9. Probable alternative or concomitant diagnoses which in the opinion of the investigator could account for the patient's HF symptoms and signs (e.g., anaemia, hypothyroidism). 10. Body mass index >50 kg/m². 11. Primary pulmonary hypertension, chronic pulmonary embolism, severe pulmonary disease including COPD (i.e., requiring home oxygen, chronic nebuliser therapy or chronic oral steroid therapy, or hospitalisation for exacerbation of COPD requiring ventilatory assist within 12 months prior to enrolment). 12. Previous cardiac transplantation, or complex congenital heart disease. Planned cardiac resynchronisation therapy. 13. HF due to any of the following: known infiltrative cardiomyopathy (e.g., amyloid, sarcoid, lymphoma, endomyocardial fibrosis), active myocarditis, constrictive pericarditis, cardiac tamponade, known genetic hypertrophic cardiomyopathy or obstructive hypertrophic cardiomyopathy, ARVC/D, or uncorrected primary valvular disease. 14. A life expectancy of less than 2 years due to any non-cardiovascular condition, based on investigator's clinical judgement. 15. Inability of the patient, in the opinion of the investigator, to understand and/or comply with study medications, procedures and/or follow-up OR any conditions that, in the opinion of the investigator, may render the patient unable to complete the study. 16. Active malignancy requiring treatment (with the exception of basal cell or squamous cell carcinomas of the skin). 17. Acute or chronic liver disease with severe impairment of liver function (e.g., ascites, oesophageal varices, coagulopathy). 18. Women of child-bearing potential (i.e., those who are not chemically or surgically sterilised or post-menopausal) not willing to use a medically accepted method of contraception considered

Parameter	Description
	<p>reliable in the judgment of the investigator OR who have a positive pregnancy test at randomisation OR who are breast-feeding.</p> <p>19. Involvement in the planning and/or conduct of the study (applies to both AstraZeneca personnel and/or personnel at the study site).</p> <p>20. Previous randomisation in the present study.</p> <p>21. Participation in another clinical study with a treatment or device during the last month prior to enrolment.</p>
Settings and locations where the data were collected	353 sites across 20 countries in Europe and Saudi Arabia, Asia, Latin America and North America.
Trial drugs	<ul style="list-style-type: none"> • Dapagliflozin 10 mg oral once daily (N=3,131) in addition to SoC therapies already being taken by the patients • Placebo (N=3,132) in addition to SoC therapies already being taken by the patients
Permitted and disallowed concomitant medications	<p>Disallowed medications:</p> <ul style="list-style-type: none"> • SGLT2 inhibitors other than dapagliflozin as study medication. <p>Permitted medications:</p> <ul style="list-style-type: none"> • HF medications in accordance with local guidelines, including treatment of hypertension, ischemic heart disease, atrial fibrillation, diabetes, hyperlipidaemia.
Primary outcomes	<p>Time to first occurrence of any of the components of this composite:</p> <ul style="list-style-type: none"> • CV mortality • HF events, including <ul style="list-style-type: none"> ○ HHF ○ UHFV (e.g., emergency department or outpatients visit)
Other outcomes used in the economic model/specified in the scope	<ul style="list-style-type: none"> • Total number of HF events and CV deaths • Change from baseline in the TSS of the KCCQ at 8 months • Time to the occurrence of CV mortality • Time to the occurrence of mortality from any cause
Safety	SAEs, DAEs, amputations, AEs leading to amputation and potential risk factor AEs for amputations affecting lower limbs.
Pre-planned subgroups	<p>Pre-specified:</p> <ul style="list-style-type: none"> • Age at enrolment (\leq median/$>$median) • Sex (male/female) • Ethnicity (white/black or African American/Asian/other) • Geographic region (Asia [China, Japan, Taiwan, Vietnam]/ Europe and Saudi Arabia [Belgium, Bulgaria, Czech Republic, France, Hungary, Netherlands, Poland, Romania, Russia, Saudi Arabia, Spain]/ North America [Canada, US]/ Latin America [Argentina, Brazil, Mexico, Peru]) • NYHA class at enrolment (II, III/IV) • LVEF at enrolment (≤ 49/ 50 to 59/ ≥ 60) • NT-proBNP (\leqmedian/$>$median) • Randomised during HHF or within 30 days of discharge (yes/no) • eGFR at enrolment (≥ 60 mL/min/1.73 m² / < 60 mL/min/1.73 m²) • BMI (< 30 kg/m²/≥ 30 kg/m²) • T2DM at enrolment (yes/no)

Parameter	Description
	<ul style="list-style-type: none"> • SBP at randomisation (\leq median/ $>$median) • Atrial fibrillation or flutter at enrolment ECG (yes/no) • HFimpEF; prior LVEF $\leq 40\%$ with improvement to $>40\%$ before study enrolment

^aTypical symptoms associated with heart failure: breathlessness, orthopnoea, paroxysmal nocturnal dyspnoea, reduced exercise tolerance, fatigue, tiredness, increased time to recover after exercise, ankle swelling; Signs associated with HF: More specific: elevated jugular venous pressure, hepatojugular reflux, third heart sound (gallop rhythm), laterally displaced apical impulse; Less specific: weight gain (>2 kg/week), weight loss (in advanced HF), tissue wasting (cachexia), cardiac murmur, peripheral oedema (ankle, sacral, scrotal), pulmonary crepitations, reduced air entry and dullness to percussion at lung bases (pleural effusion), tachycardia, irregular pulse, tachypnoea, Cheyne-Stokes respiration, hepatomegaly, ascites, cold extremities, oliguria, narrow pulse pressure. ^bLeft Atrial Enlargement defined by at least 1 of the following: left atrial (LA) width (diameter) ≥ 3.8 cm or LA length ≥ 5.0 cm or LA area ≥ 20 cm² or LA volume ≥ 55 mL or LA volume index ≥ 29 mL/m². Left Ventricular Hypertrophy defined by septal thickness or posterior wall thickness ≥ 1.1 cm.

Source: DELIVER CSR.⁷⁸ Solomon *et al.* (2022);⁷⁶ Solomon *et al.* (2022) – Supplementary Appendix.⁸⁵

Abbreviations: AEs: adverse events; ARVC/D: arrhythmogenic right ventricular cardiomyopathy/dysplasia; BMI: body mass index; CABG: coronary artery bypass graft; COPD: chronic obstructive pulmonary disease; CKD-EPI: chronic kidney disease epidemiology; CV: cardiovascular; DAEs: adverse events leading to treatment discontinuation; DMC: data monitoring committee; EC: executive committee; ECG: echocardiogram; eGFR: estimated glomerular filtration rate; HF: heart failure; HHF: hospitalisation for heart failure; KCCQ: Kansas City Cardiomyopathy Questionnaire; LA: left atrial; LVEF: left ventricular ejection fraction; NT-proBNP: N-terminal pro B-type natriuretic peptide; NYHA: New York Heart Association; MI: myocardial infarction; MR: magnetic resonance; MRI: magnetic resonance imaging; PACD: primary analysis censoring date; PCI: percutaneous coronary intervention; SAEs: serious adverse events; SBP: systolic blood pressure; SGLT2: sodium-glucose co-transporter-2; SoC: standard of care; T2DM: Type 2 diabetes mellitus; TIA: transient ischemic attack; TSS: Total Symptom Score; UHFV: urgent heart failure visit.

Figure 4: DELIVER trial design

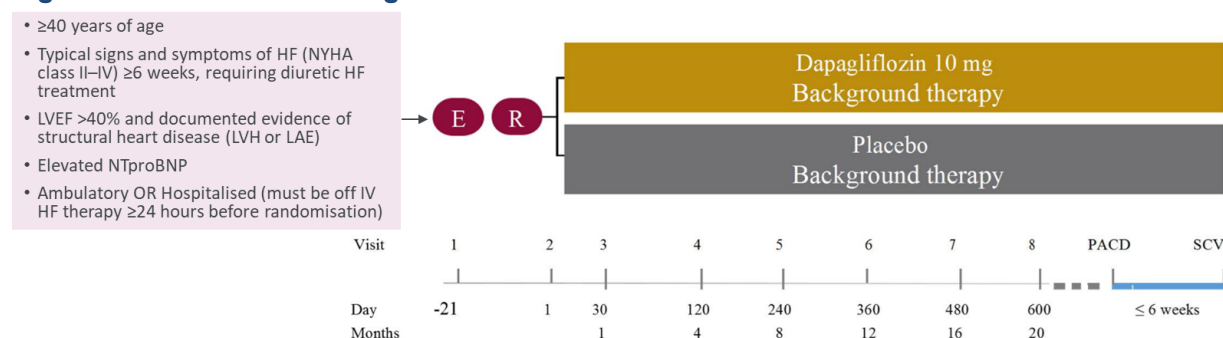

Source: Solomon *et al.* (2022) – Supplementary Appendix.⁸⁵

Abbreviations: E: enrolment; HF: heart failure; IV: intravenous; LAE: left atrial enlargement; LVH: left ventricular hypertrophy; NYHA: New York Heart Association; PACD: primary analysis censoring date; R: randomisation; SCV: study closure visit.

B.2.3.2. Baseline characteristics and demographics

Patient characteristics at baseline in DELIVER are summarised in Table 8. Overall, 6,263 patients were randomised; 3,131 in the dapagliflozin group and 3,132 in the placebo group. In total, [REDACTED] of patients were female.^{76, 78} The mean age was 71.7 years.⁸⁰ Demographic and other baseline patient characteristics were well balanced between treatment groups in the full study population.⁷⁶ Overall, [REDACTED] of patients had T2DM at baseline.⁷⁸ Median LVEF was [REDACTED], median NT-proBNP was 1,011.0 pg/mL, mean eGFR was 61.0 mL/min/1.73m², and median systolic BP was [REDACTED] mmHg.^{76, 78, 80} Over 18% [REDACTED] of enrolled patients had HFimpEF, whereby their LVEF was $\leq 40\%$ prior to study enrolment when it had increased to $>40\%$.^{76, 79} This population which was usually excluded from trials, tend to have worse outcomes than patients without a history of HF.⁸⁶ Also, outcomes tend to worsen for this patient population once a disease-

Company evidence submission template for dapagliflozin for treating chronic heart failure with preserved or mildly reduced ejection fraction [ID1648]

modifying treatment is discontinued.⁸⁶ Therefore, the DELIVER trial provides further evidence of the benefit that an SGLT2 inhibitor in addition to standard care may offer to those with residual symptoms of HF, thus HFimpEF.⁸⁶

Most patients were diagnosed with HF <5 years before enrolment.^{78, 80} A total of [REDACTED] patients [REDACTED] had a history of being hospitalised for HF prior to study enrolment.⁷⁸

At randomisation, treatment of HF symptoms and co-morbidities was balanced between treatment groups.⁷⁶ In total, [REDACTED].⁷⁸ The high proportion of patients taking beta blockers, ACEi/ARB/ARNI and MRAs⁸⁰ which are not typically prescribed to treat HF with LVEF >40% is due to a combination of these being prescribed to treat comorbidities such as hypertension and the fact that the DELIVER trial contained over 18% of patients with HFimpEF, in whom clinical guidelines recommend to continue with treatments initiated to treat HFrEF even when their LVEF increases to >40%.³⁰ Compared with the cohort of real-world patients with HF and an LVEF >40% from the CPRD dataset,⁶² the rates of treatment with these therapies was generally a little higher (DELIVER versus CPRD: ACEi: [REDACTED] versus [REDACTED]; ARB: [REDACTED] versus [REDACTED]; ARNI: [REDACTED] versus [REDACTED]; beta-blocker: [REDACTED] versus [REDACTED]; MRA: [REDACTED] versus [REDACTED], respectively), but the same is true for the use of loop diuretics (DELIVER versus CPRD: [REDACTED] versus [REDACTED]) which are the established SoC symptomatic treatments in these patients.^{62, 78} This indicates that the DELIVER trial cohort represented a slightly better-treated group of patients compared with real-world clinical practice in the UK which is to be expected given the clinical trial setting.¹⁰

UK clinical experts consulted by AstraZeneca expressed confidence that the DELIVER trial characteristics at baseline were overall considered generalisable of the patients expected to receive dapagliflozin in UK clinical practice.¹⁰

Table 8: Characteristics of participants in DELIVER across treatment groups

Baseline characteristics	Dapagliflozin (N=3,131)	Placebo (N=3,132)	Total (N=6,263)
Demographic characteristics⁷⁶			
Mean age (years)	71.8	71.5	71.7
Female sex, n (%)	1,364 (43.6)	1,383 (44.2)	[REDACTED]
Ethnicity, n (%)			
White	2,214 (70.7)	2,225 (71.0)	[REDACTED]
Black	81 (2.6)	78 (2.5)	159 (2.5)
Asian	630 (20.1)	644 (20.6)	[REDACTED]
American Indian or Alaska Native	[REDACTED]	[REDACTED]	189 (3.0)
Other	[REDACTED]	[REDACTED]	[REDACTED]
Region, n (%)			
Asia	607 (19.4)	619 (19.8)	1,226 (19.6)
Europe and Saudi Arabia	1,494 (47.7)	1,511 (48.2)	3,005 (48.0)
North America	428 (13.7)	423 (13.5)	851 (13.6)
Latin America	602 (19.2)	579 (18.5)	1,181 (18.9)
Vital signs at baseline			

Baseline characteristics	Dapagliflozin (N=3,131)	Placebo (N=3,132)	Total (N=6,263)
Median pulse rate (Beats/min) ^a , (min, max)	██████████	██████████	██████████
Median systolic blood pressure (mmHg) ^a , (min, max)	██████████	██████████	██████████
Time from diagnosis and HHF			
Time from diagnosis of HF to enrolment, n (%)			
0-3 Month	██████████	██████████	██████████
>3-6 Months	██████████	██████████	592 (9.5)
>6-12 Months	██████████	██████████	██████████
>1-2 Years	██████████	██████████	995 (15.9)
>2-5 Years	██████████	██████████	1,569 (25.1)
>5 Years	██████████	██████████	██████████
Prior HF hospitalisation, n (%)	1,270 (40.6)	1,269 (40.5)	██████████
Randomised during HHF or within 30 days of discharge, subacute ^b , n (%)	328 ██████████	326 ██████████	654 ██████████
Time from last HF hospitalisation to randomisation, n (%)			
Randomised in hospital	██████████	██████████	90 ██████████
1-7 Days	██████████	██████████	147 ██████████
8-30 Days	██████████	██████████	417 ██████████
31 Days-3 Months	██████████	██████████	██████████
>3-6 Months	██████████	██████████	██████████
>6-12 Months	██████████	██████████	██████████
>1-2 Years	██████████	██████████	██████████
>2-5 Years	██████████	██████████	██████████
>5 Years	██████████	██████████	██████████
No prior HF hospitalisation	██████████	██████████	██████████
HF characteristics at baseline			
NYHA functional classification, ^a n (%)			
I	██████████	██████████	1 (0.0)
II	2,314 (73.9)	2,399 (76.6)	4,713 (75.3)
III	807 (25.8)	724 (23.1)	1,531 (24.4)
IV	10 (0.3)	8 (0.3)	18 (0.3)
Median LVEF (%), (Q1, Q3)	██████████	██████████	██████████
LVEF group, n (%)			
≤ 40 ^c	██████████ ^c	██████████ ^c	4 (0.1) ^c
≥ 41-49	██████████	██████████	██████████

Baseline characteristics	Dapagliflozin (N=3,131)	Placebo (N=3,132)	Total (N=6,263)
≥ 50-59	1,133 (36.2)	1,123 (35.9)	2,256 (36.0)
≥ 60	931 (29.7)	960 (30.7)	1,891 (30.2)
Patients with prior LVEF ≤40%, n (%)	572 (18.3)	579 (18.5)	██████████
Left ventricular hypertrophy, n (%)	██████████	██████████	██████████
Left atrial enlargement, n (%)	██████████	██████████	██████████
Atrial fibrillation or flutter at enrolment ECG, n (%)	1,327 (42.4)	1,317 (42.1)	2,644 (42.2)
Median NT-proBNP, pg/mL ^a (Q1, Q3)	██████████	██████████	1,011 (623, 1751)
Disease-related medical history, n (%)			
T2DM	1,401 (44.7)	1,405 (44.9)	██████████
Valvular heart disease	██████████	██████████	██████████
Ventricular arrhythmia	██████████	██████████	██████████
Hypertension	2,755 (88.0)	2,798 (89.3)	██████████
Syncope	██████████	██████████	██████████
Myocardial infarction	██████████	██████████	██████████
Unstable angina pectoris	██████████	██████████	██████████
Stable angina pectoris	██████████	██████████	██████████
Stroke	██████████	██████████	██████████
Transient ischaemic attack	██████████	██████████	██████████
Peripheral arterial occlusive disease	██████████	██████████	██████████
Neuropathy	██████████	██████████	██████████
Foot ulcer	██████████	██████████	██████████
Coronary artery stenosis	██████████	██████████	██████████
Carotid artery stenosis	██████████	██████████	██████████
Renal artery stenosis	██████████	██████████	██████████
Aneurysm of abdominal aorta	██████████	██████████	██████████
Pulmonary embolism	██████████	██████████	██████████
Dyslipidaemia	██████████	██████████	██████████
Chronic kidney disease	██████████	██████████	██████████
Chronic obstructive pulmonary disease	██████████	██████████	██████████
Asthma	██████████	██████████	██████████
Gout	██████████	██████████	██████████
Sleep apnoea	██████████	██████████	██████████
Osteoporosis	██████████	██████████	██████████
Malignant neoplasm	██████████	██████████	██████████

Baseline characteristics	Dapagliflozin (N=3,131)	Placebo (N=3,132)	Total (N=6,263)
Baseline characteristics based on clinical laboratory measurements			
Median serum creatinine (µmol/L) ^a (min, max)	██████████	██████████	██████████
Mean eGFR (mL/min/1.73m ²) ^a (min, max)	██████████	██████████	██████████
eGFR category (mL/min/1.73m ²) ^a , n (%)			
<25	██████	██████	██████
25- <30	██████	██████	██████
30- <45	██████	██████	██████
45- <60	██████	██████	██████
<60	██████████	██████████	██████████
≥ 60	██████████	██████████	██████████
HF and CV medication at randomisation, n (%)			
ACEi	1,144 (36.5)	1,151 (36.7)	██████████
ARB	1,133 (36.2)	1,139 (36.4)	██████████
ARNI	165 (5.3)	136 (4.3)	██████████
Beta blocker	2,592 (82.8)	2,585 (82.5)	██████████
Calcium channel blocker	██████████	██████████	██████████
ACEi or ARB	██████████	██████████	██████████
ACEi, ARB, or ARNI	██████████	██████████	██████████
(ACEi, ARB, or ARNI) and beta blocker	██████████	██████████	██████████
(ACEi, ARB, or ARNI) and beta blocker and MRA	██████████	██████████	██████████
Diuretics	██████████	██████████	██████████
MRA	1340 (42.8)	1327 (42.4)	██████████
Loop diuretics	2403 (76.7)	2408 (76.9)	██████████
Other (non-loop non-MRA) diuretics	██████████	██████████	██████████
Digitalis glycosides	██████████	██████████	██████████
Vasodilators	██████████	██████████	██████████
Lipid lowering drugs	██████████	██████████	██████████
Statins	██████████	██████████	██████████
Antithrombotic agents	██████████	██████████	██████████

^aThe last value on or prior to date of first dose of treatment. ^bSubacute defined as enrolled and randomised during HHF or within 30 days of discharge from HHF. ^c██████████

██████████, 4 patients had LVEF ≤ 40%: ██████████

Source: Solomon *et al.* (2022);⁷⁶ Solomon *et al.* (2022);⁸⁰ Solomon *et al.* (2022) – Supplementary Appendix;⁸⁵ Vaduganathan *et al.* (2020);⁸⁷ Cunningham *et al.* (2022);⁸⁸ Ostrominski *et al.* (2022);⁸⁹ DELIVER CSR.⁷⁸

Abbreviations: ACEi: angiotensin converting enzyme inhibitor; ARB: angiotensin receptor blocker; ARNI:

angiotensin receptor neprilysin inhibitor; CV: cardiovascular; ECG: echocardiogram; eGFR: estimated glomerular filtration rate; HF: heart failure; HHF: hospitalisation for heart failure; max: maximum; min: minimum; LVEF: left ventricular ejection fraction; MRA: mineralocorticoid receptor antagonist; N: number of patients in treatment group; n: number of patients included in analysis; NT-proBNP: N-terminal pro-brain natriuretic peptide; NYHA: New York Heart Association; Q1: first quartile; Q3: third quartile; T2DM: type 2 diabetes mellitus.

B.2.4. Statistical analysis and definition of study groups in the relevant clinical effectiveness evidence

An overview of the patient population analysis sets and details of the statistical analysis conducted in DELIVER are provided below.

B.2.4.1. Definitions of patient population analysis sets

Full analysis set (FAS): All patients who were randomised to treatment were included in the FAS, irrespective of their protocol adherence and continued participation in the study. Patients were analysed according to their randomised treatment assignment, irrespective of the treatment actually received. The FAS was considered the primary analysis set for the intention-to-treat (ITT) analysis of primary and secondary variables and for the exploratory efficacy variables. A subset of the FAS consisting of patients with a baseline LVEF <60% (i.e., the subpopulation with LVEF <60%) was analysed separately as part of the confirmatory statistical testing procedure.⁸⁵

Safety analysis set (SAS): All randomised patients who received at least one dose of treatment were included in the SAS.⁸⁵

B.2.4.2. Statistical analysis

A summary of the statistical analysis in DELIVER is provided in Table 9.

Table 9: Summary of statistical analyses in DELIVER

DELIVER	Description
Hypothesis objective	That dapagliflozin is superior to placebo, when added to SoC, in reducing the primary composite endpoint of CV mortality and HF events in patients with HF and an LVEF >40%.
Statistical analysis	<ul style="list-style-type: none"> All patients who were randomised to treatment were included in the FAS, irrespective of their protocol adherence and continued participation in the study. The primary variable was the time to first event included in the primary composite endpoint of CV mortality or an HF event, which was tested simultaneously in the full study population and in the subpopulation with LVEF <60%. The primary analysis was based on the intention-to-treat principle using the FAS, including events with onset on or prior to PACD, adjudicated and confirmed by the Clinical Event Adjudication Committee. In the analysis of the primary composite endpoint, dapagliflozin versus placebo was compared using a Cox proportional hazards model with a factor for treatment group, stratified by T2DM status at randomisation. The primary and the secondary endpoints were tested in a hierarchical sequence. Statistical significance was assessed in 2 branches (Figure 5) in the prespecified order of the endpoints and populations. To control the overall type I error rate at 5% two-sided, the significance level was adjusted for a pre-planned interim analysis of efficacy, resulting in a significance level of 4.8% for the final analysis. The total significance level was split for the dual primary analysis, allocating an alpha of 2.4% to test the primary endpoint in the full population. The resulting alpha for testing the primary endpoint in the LVEF <60 subpopulation was determined to 3.8% utilising

DELIVER	Description
	<p>the correlation between the full population and the LVEF < 60 subpopulation.</p> <ul style="list-style-type: none"> • Demonstration of superiority for the primary composite endpoint initiated sequential testing of the secondary endpoints. An alpha of 2.4% and 3.8% was used to test the primary composite endpoint in the full study population and in the subpopulation with LVEF <60%, respectively. Since both primary null hypotheses were rejected, the subsequent hypotheses in each branch were tested at 2.4%, in the order of the testing hierarchy. Further, because all hypotheses in the branch in which the primary analysis was in the subpopulation with LVEF <60% were rejected, alpha was recycled to the other branch, where remaining unrejected hypotheses were re-tested at full alpha adjusted for interim analysis (i.e., 4.8%). • For time to first event, dapagliflozin versus placebo was compared using a Cox proportional hazards model with a factor for treatment group, stratified by T2DM status at randomisation. Recurrent HF events and CV mortality were analysed by the semi-parametric proportional rates model (known as the LWYY method).⁹⁰
<p>Sample size, power calculation</p>	<ul style="list-style-type: none"> • The study was event-driven. • Originally, assuming a true HR of 0.80 between dapagliflozin and placebo, using a two-sided alpha of 5%, 844 primary endpoint events were targeted in order to provide a statistical power of 90% for the test of the primary endpoint. • To allow testing for the dual primary analysis, alpha was allocated to each test to ensure strong control of the overall type I error rate. The target number of patients with a primary endpoint was increased to 1,117 in order to provide adequate statistical power for each test. It was anticipated that at least 70% of the events (i.e., approximately 780 events) would be available for the subpopulation with LVEF <60%. For illustration, [REDACTED], respectively, whereas an alpha allocation of 1.5% to the full study population would result in 90% power. This was based on an overall 1:1 allocation between dapagliflozin and placebo. • The assumed HR of 0.80 was originally chosen as a conservative assumption based on the observed HRs of 0.72 (95% CI: 0.50, 1.04) in the EMPA-REG OUTCOME study⁹¹ and of 0.61 (95% CI: 0.46, 0.80) in the CANVAS programme⁹² considering that these HRs were based on post-hoc analyses in subgroups with limited documentation of baseline HF diagnosis, not characterised by ejection fraction. • The event rate assumptions were based on subgroup analyses of the TOPCAT and I-PRESERVE studies by geographic region, NT-proBNP levels, prior HHF, and T2DM status. The original sample size calculation (approximately 4,700 randomised patients) built on the assumption of an annual event rate of 9% in the placebo group for the majority of eligible patients with HF and an LVEF>40%, importantly all with NT-proBNP≥ 300 pg/mL by inclusion criterion. Additionally, a subacute subgroup with a higher event rate was also included. Assuming 20% of patients from the subacute subgroup with an annual event rate of 24% during the first year and 9% thereafter, the original sample size of 4,700 patients was estimated to provide the required target number of 844 patients with a primary event during a recruitment period of 18 months and a minimum follow-up period of 15 months. • Based on the ongoing blinded monitoring of event accrual and with an assumed proportion of 11% patients from the subacute subgroup, the sample size was increased from original 4,700 to approximately 6,100 randomised patients to obtain the increased target number of 1,117 patients

DELIVER	Description
	<p>with a primary event. The recruitment period was anticipated to increase from the original 18 months to 26 months and a minimum follow-up period of 13.5 months (total study duration 39 months). Recruitment could be marginally prolonged in a few countries to meet local targets.</p> <ul style="list-style-type: none"> The expected number of patients who would be lost to follow-up was expected to be small; hence, these were not considered in the determination of the sample size.
Data management, patient withdrawals	All patients who underwent randomisation were included in the analyses of the primary and secondary outcomes.

Source: Solomon *et al.* (2022) – Supplementary Appendix;⁸⁵ DELIVER CSR.⁷⁸

Abbreviations: CI: confidence interval; CV: cardiovascular; FAS: full analysis set; HF: heart failure; HHF: hospitalisation for heart failure; HR: hazard ratio; LVEF: left ventricular ejection fraction; LWYY: Lin Wei Yang Ying; NT-proBNP: N-terminal pro-brain natriuretic peptide; PACD: primary analysis censoring date; SoC: standard of care; T2DM: type 2 diabetes mellitus.

Figure 5: Testing procedure for DELIVER

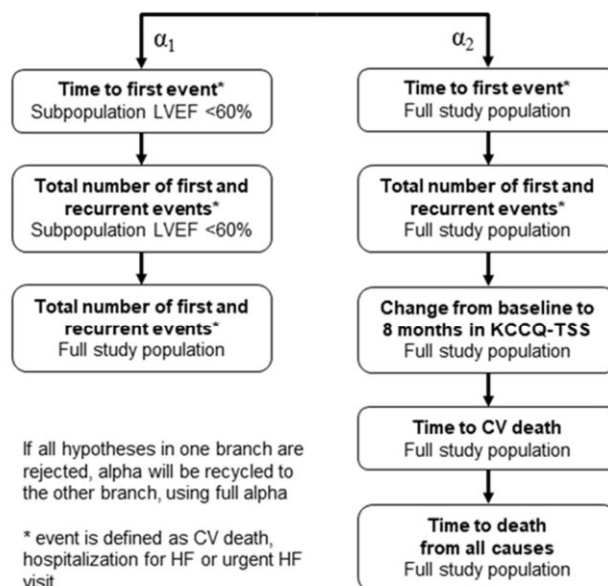

Source: Solomon *et al.* (2022) – Supplementary Appendix.⁸⁵

Abbreviations: CV: cardiovascular; HF: heart failure; KCCQ: Kansas City Cardiomyopathy Questionnaire; LVEF: left ventricular ejection fraction; TSS: Total Symptom Score.

B.2.4.3. Participant flow in the relevant randomised controlled trials

Participant flow in DELIVER is summarised in Figure 6.

Figure 6: Patient disposition in DELIVER

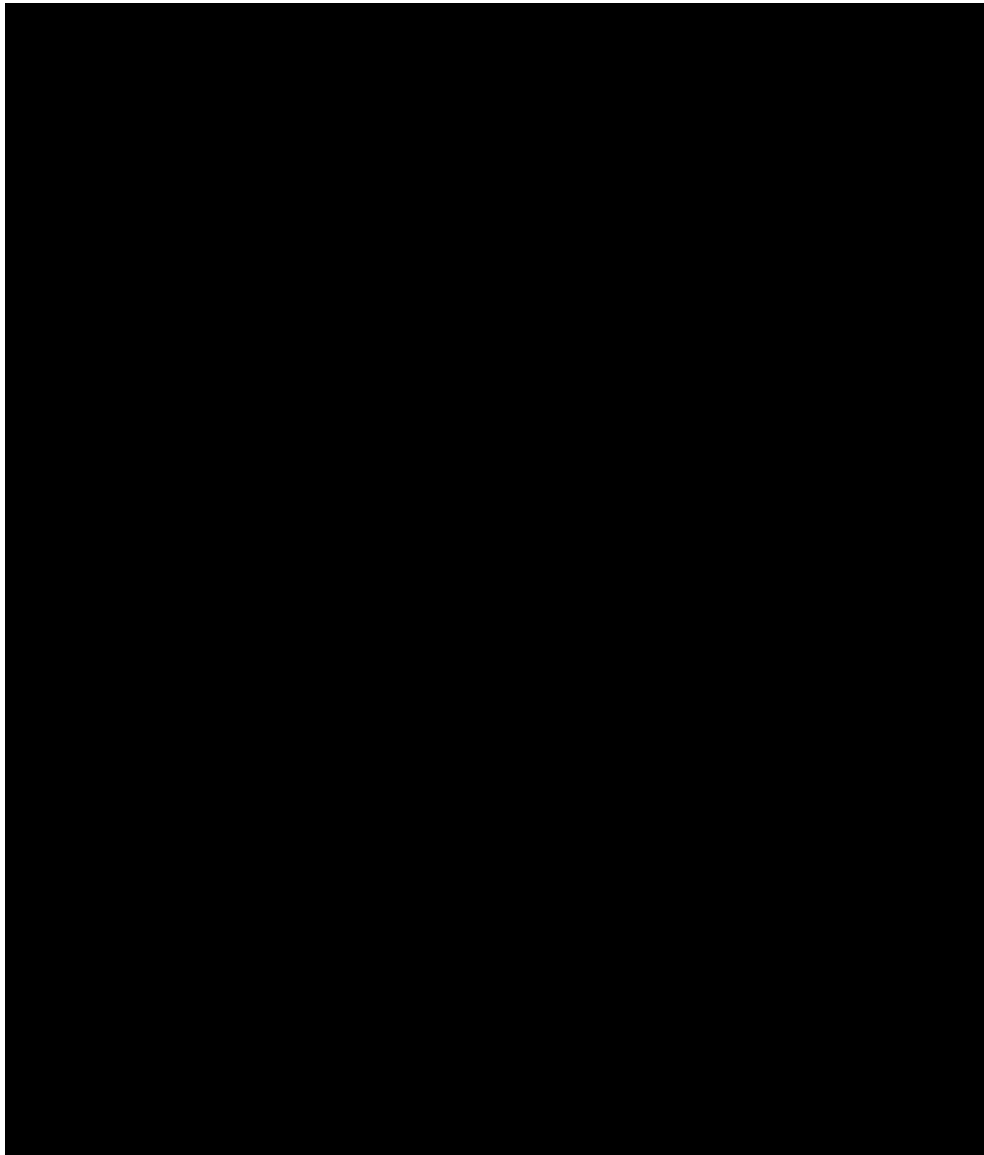

Source: DELIVER CSR.⁷⁸

Abbreviations: DKA: diabetic ketoacidosis; IP: investigational product; PACD: primary analysis censoring date.

B.2.5. Critical appraisal of the relevant clinical effectiveness evidence

A critical appraisal of the DELIVER trial is provided in Table 10.

Table 10: Critical appraisal of DELIVER

DELIVER (NCT03619213)	Risk of bias
Was randomisation carried out appropriately?	Yes. Patients were randomised in a 1:1 ratio stratified by diabetes status at baseline. Randomisation was performed in balanced blocks to ensure approximate balance between the treatment groups. Randomisation codes were computer generated.

DELIVER (NCT03619213)	Risk of bias
Was the concealment of treatment allocation adequate?	Yes. An interactive voice/web-response system was used to determine treatment assignment and matching placebo was used.
Were the groups similar at the outset of the study in terms of prognostic factors?	Yes. Demographics and disease characteristics were balanced between the groups and patients were stratified according to baseline diabetes status.
Were the care providers, participants and outcome assessors blind to treatment allocation?	Yes. The study was double-blinded. The interactive voice/web-response system was used to manage study agent inventory while ensuring that no one at the sites had to be unblinded. The blinding of treatment is ensured by using a double-blind technique.
Were there any unexpected imbalances in drop-outs between groups?	No. Discontinuations of study medication were low and well-balanced between treatment arms.
Is there any evidence to suggest that the authors measured more outcomes than they reported?	No. Based on the clinical study report all outcomes are reported in detail.
Did the analysis include an intention-to-treat analysis? If so, was this appropriate and were appropriate methods used to account for missing data?	Yes. Efficacy analyses were performed on the full analysis set. There were no missing data for the primary endpoint and other event-based outcomes. For event-based outcomes, patients were censored at last clinical event assessment, and follow-up of endpoints was good as described in Figure 6 in terms of few unknown vital status and high proportion of complete follow-up.
Did the authors of the study publication declare any conflicts of interest?	Yes. The DELIVER trial was sponsored by AstraZeneca. The sponsor was involved in the design and write up of the trial.

B.2.6. Clinical effectiveness results of the relevant studies:

DELIVER

B.2.6.1. Primary efficacy outcome: composite of CV mortality and HF events

Dapagliflozin statistically significantly reduced the risk of the primary composite endpoint of CV mortality and HF events by 18% compared with placebo⁷⁶

Dapagliflozin was statistically significantly superior to placebo in reducing the incidence of the primary composite endpoint of CV mortality or a HF event (HR 0.82; 95% CI: 0.73, 0.92; $p < 0.001$; Figure 7).⁷⁶ Over a median duration of follow-up of 2.3 years, there were 512 and 610 patients with CV mortality or a HF event in the dapagliflozin and placebo groups, respectively, corresponding to event rates per 100 patient-years of 7.8 and 9.6, respectively.⁷⁶ This meant that fewer patients experienced either CV mortality or a HF event on treatment with dapagliflozin compared with placebo.^{76,78} Of a total of 1,122 patients with a composite event, 300 patients had CV mortality as their first event.⁸⁷

A Kaplan-Meier (KM) analysis of the composite of CV mortality or an HF event is presented in Figure 7.⁷⁶ The curves diverged early and the separation was maintained throughout the study.

Figure 7: KM plot of the primary composite endpoint (CV mortality and HF events) in DELIVER

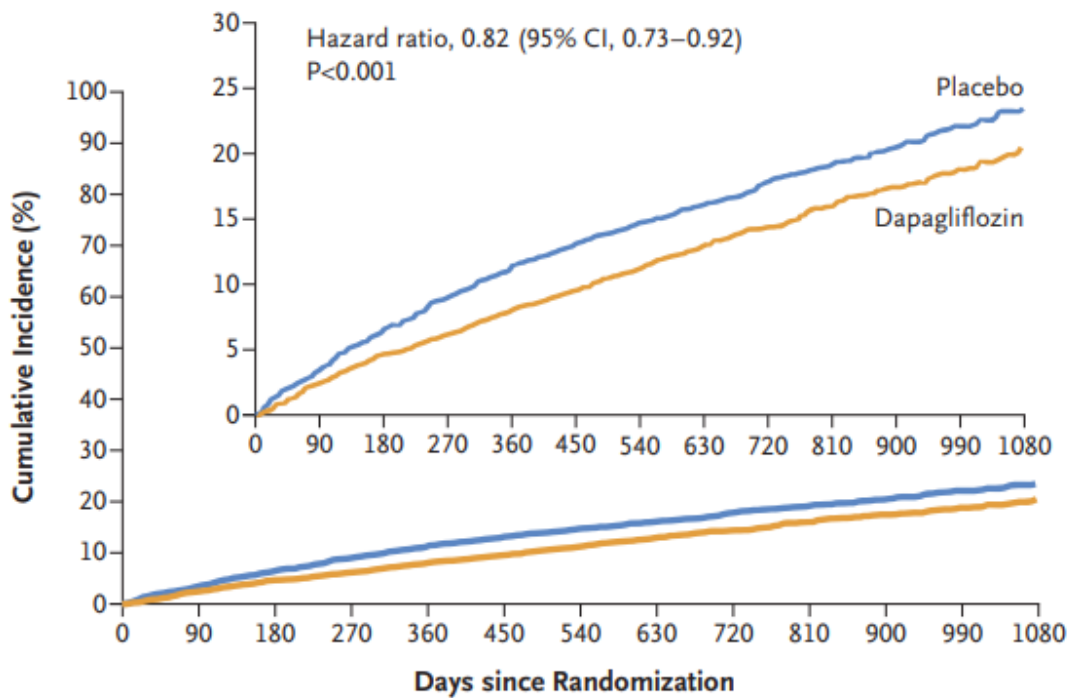

No. at Risk

Placebo	3132	3007	2896	2799	2710	2608	2318	2080	1923	1554	1140	772	383
Dapagliflozin	3131	3040	2949	2885	2807	2716	2401	2147	1982	1603	1181	801	389

Source: Solomon *et al.* (2022).⁷⁶

Abbreviations: CI: confidence interval; CV: cardiovascular; Dapa: dapagliflozin; D: dapa 10mg; FAS: full analysis set; HF: heart failure; HR: hazard ratio; KM: Kaplan-Meier; N: number of patients; P: placebo.

All components of the primary composite endpoint [REDACTED] to the treatment effect (Figure 8).⁷⁸

Figure 8: Forest plot of the primary composite endpoint (CV mortality and HF events) and the individual components in DELIVER^a



Source: DELIVER CSR.⁷⁸

Abbreviations: CI: confidence interval; CV: cardiovascular; Dapa: dapagliflozin; FAS: full analysis set; HF: heart failure; HHF: hospitalisation for heart failure; HR: hazard ratio; N: number of patients in treatment group; T2DM: type 2 diabetes mellitus; UHFV: urgent heart failure visit.

Sensitivity analysis of primary outcome

Results of the sensitivity analysis, [REDACTED]

.⁷⁸

Results of the COVID-19 sensitivity analysis, in which patients were censored at the onset date of the first AE associated with COVID-19 infection, were also consistent with those of the main analysis.⁷⁶

B.2.6.2. Secondary efficacy outcomes

Composite of CV mortality and recurrent HF events

Dapagliflozin statistically significantly reduced the risk of the secondary composite endpoint of CV mortality and recurrent HF events by 23% compared with placebo⁷⁶

Dapagliflozin was statistically significantly superior to placebo in reducing the incidence of the composite of total (first and recurrent/ repeat) HF events and CV mortality (RR 0.77; 95% CI: 0.67, 0.89; $p < 0.001$; Table 11). There were 815 and 1,057 events of the composite endpoint in the dapagliflozin and placebo groups, respectively, corresponding to event rates per 100 patient-years of 11.8 and 15.3, respectively.⁷⁶ Dapagliflozin provided a statistically significant reduction versus placebo in the incidence of recurrent HF events (RR 0.73; 95% CI: 0.62, 0.87; $p = 0.0003$).⁷⁸ Dapagliflozin reduced the incidence of CV mortality although the difference was not statistically significant (HR 0.88; 95% CI: 0.74, 1.05; $p = 0.1678$).^{76,78}

Company evidence submission template for dapagliflozin for treating chronic heart failure with preserved or mildly reduced ejection fraction [ID1648]

© AstraZeneca (2022). All rights reserved

Table 11: Analysis of the composite endpoint of CV mortality and recurrent HF events in DELIVER

Variable	Dapagliflozin (N=3,131)		Placebo (N=3,132)		Dapagliflozin versus placebo		
	Number of events	Event rate ^c	Number of events	Event rate ^c	Rate/hazard ratio ^a	95% CI	p-value
Composite endpoint of CV mortality and recurrent HF events	815	11.8	1,057	15.3	0.77	(0.67, 0.89)	<0.001
Recurrent HF events ^b	■	■	■	■	0.73	(0.62, 0.87)	0.0003
CV mortality ^a	231	3.3	261	3.8	0.88	(0.74, 1.05)	0.1678

Source: Solomon *et al.* (2022);⁷⁶ DELIVER CSR.⁷⁸

Abbreviations: CI: confidence interval; CV: cardiovascular; Dapa: dapagliflozin; HF: heart failure; HHF: hospitalisation for heart failure; LWYY: Lin Wei Yang Ying; N: number of patients in treatment group; RR: rate ratio; T2DM: type 2 diabetes mellitus; UHFV: urgent heart failure visit.

■ patients in the dapagliflozin group had ≥ 1 and ≥ 2 of the events included in the composite endpoint versus the placebo group (Table 12).⁷⁸

Table 12: Summary of HF events and CV mortality – number of events per patient in DELIVER

Variable	Number of patients (%)			
	HF events ^a		HF events ^a and CV mortality	
	Dapagliflozin (N=3,131)	Placebo (N=3,132)	Dapagliflozin (N=3,131)	Placebo (N=3,132)
Events per patient				
0	■	■	■	■
≥ 1	■	■	■	■
≥ 2	■	■	■	■
Total events	■	■	■	■

Source: DELIVER CSR.⁷⁸

Abbreviations: CV: cardiovascular; Dapa: dapagliflozin; HF: heart failure; HHF: hospitalisation for health failure; N: number of patients in treatment group; UHFV: urgent heart failure visit.

Results of the COVID-19 sensitivity analysis in which patients were censored at the onset date of the first AE associated with COVID-19 infection, were consistent with those of the main analysis.⁸⁵

CV mortality

CV mortality was reduced in patients treated with dapagliflozin compared with placebo although the difference was not statistically significant^{76, 78}

There were fewer CV deaths in the dapagliflozin group compared with the placebo group (231 versus 261), not reaching statistical significance (HR 0.88; 95% CI: 0.74, 1.05; $p=0.1678$); Figure 9).^{76, 78}

Figure 9: KM plot of CV mortality in DELIVER

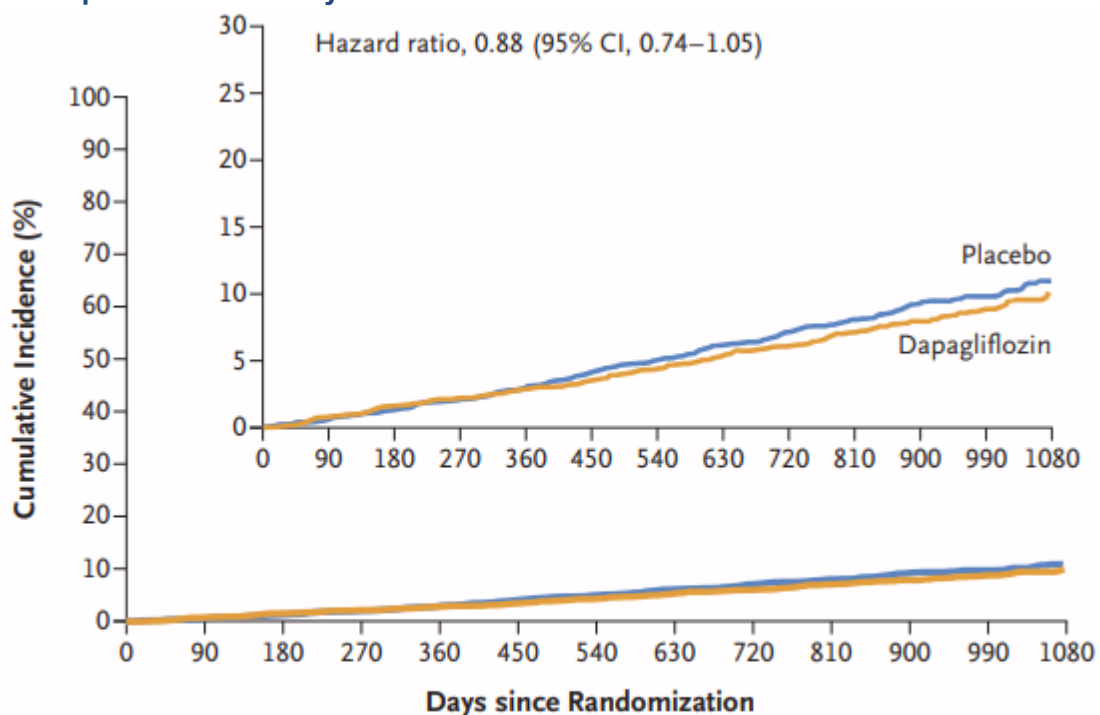

No. at Risk

Placebo	3132	3096	3054	3008	2957	2872	2570	2314	2157	1759	1306	910	451
Dapagliflozin	3131	3091	3046	3006	2960	2892	2584	2339	2171	1775	1312	903	441

Source: Solomon *et al.* (2022).⁷⁶

Abbreviations: CI: confidence interval; CV: cardiovascular; Dapa: dapagliflozin; D: dapa 10mg; HR: hazard ratio; KM: Kaplan-Meier; N: number of patients; P: placebo.

Mortality from any cause

All-cause mortality was reduced in patients treated with dapagliflozin compared with placebo although the difference was not statistically significant^{76,78}

There were fewer deaths from any cause in the dapagliflozin group compared with the placebo group (497 versus 526 not reaching statistical significance (HR 0.94; 95% CI 0.83, 1.07; $p=0.3425$; Figure 10).^{76,78}

The hierarchical testing sequence stopped before the endpoint of time to death from any cause could be assessed. Hence, the analysis of this endpoint was not conducted as part of the confirmatory testing sequence.

Figure 10: KM plot of all-cause mortality in DELIVER

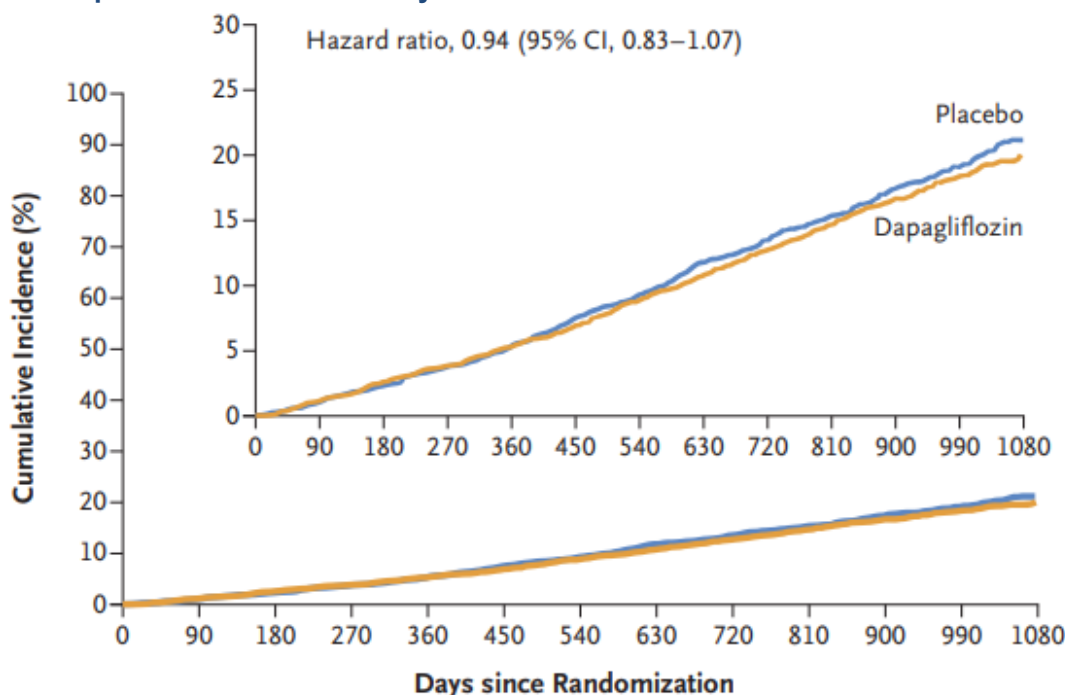

No. at Risk

Placebo	3132	3097	3058	3012	2962	2877	2575	2319	2161	1762	1309	910	451
Dapagliflozin	3131	3093	3048	3009	2962	2895	2587	2342	2174	1778	1314	905	443

Source: Solomon *et al.* (2022).⁷⁶

Abbreviations: CI: confidence interval; Dapa: dapagliflozin; D: dapa 10mg; HR: hazard ratio; KM: Kaplan-Meier; N: number of patients; P: placebo.

Adjudicated death causes are presented in Table 13. The most common adjudicated cause of mortality was CV death.

Table 13: Summary of adjudicated death classification in DELIVER^a

	Dapagliflozin (N=3,131)	Placebo (N=3,132)	Total (N=6,263)
All deaths	497 (15.9)	526 (16.8)	1,023
CV death	231 (7.4)	261 (8.3)	492
Non-CV death			
Undetermined cause of death			
Death after withdrawal of consent. Not adjudicated			

Source: DELIVER CSR;⁷⁸ Solomon *et al.* (2022);⁷⁶ Vaduganathan *et al.* (2022).⁸⁷

Abbreviations: CV: cardiovascular; Dapa: dapagliflozin; N: number of patients in treatment group; PACD: primary analysis censoring date.

Change from baseline in Total Symptom, Clinical Summary, Overall Summary and Physical Limitation Scores of KCCQ⁹³

Dapagliflozin provided significant patient-reported symptom benefits and physical limitation improvement versus placebo

At baseline, KCCQ data were available for [redacted] patients ([redacted] of the overall trial population) with

Company evidence submission template for dapagliflozin for treating chronic heart failure with preserved or mildly reduced ejection fraction [ID1648]

a median KCCQ-TSS of [REDACTED]).^{78, 93}

Dapagliflozin provided statistically significant improvements versus placebo in mean KCCQ-TSS, -PLS, -CSS and -OSS at 8 months (2.4, 1.9, 2.3 and 2.1 points higher versus placebo; p<0.001, for all).^{76, 78, 93} Improvements [REDACTED].^{78, 93} Mean changes over time in KCCQ-TSS, -PLS, -CSS and -OSS are presented in Table 14 and Figure 11.

Table 14: Change in KCCQ parameters at Month 1, Month 4 and Month 8

	Change in KCCQ parameters (point estimate [95% CI]) by Month 1, 4 and 8 (dapagliflozin versus placebo)		
	Month 1	Month 4	Month 8
TSS ^a	[REDACTED]	[REDACTED]	+2.4 (1.5, 3.3)
PLS ^a	[REDACTED]	[REDACTED]	+1.9 [REDACTED]
CSS ^a	[REDACTED]	[REDACTED]	+2.3 [REDACTED]
OSS ^a	[REDACTED]	[REDACTED]	+2.1 [REDACTED]

^aTSS quantifies the symptom frequency and severity, PLS evaluates the physical function, CSS includes the symptoms and physical function domains, and OSS summarises all key domains (TSS, physical function, quality of life and social function). Scores are transformed to a range of 0–100, in which higher scores reflect better health status.

Source: Solomon *et al.* (2022)⁷⁶; DELIVER CSR;⁷⁸ AstraZeneca UK Ltd. Data on File.⁹³

Abbreviations: CSS, Clinical Summary Score; OSS: Overall Summary score; PLS: Physical Limitation Score; TSS: Total symptom score.

Figure 11: Mean changes in KCCQ domains over time by treatment allocation^{a,b}

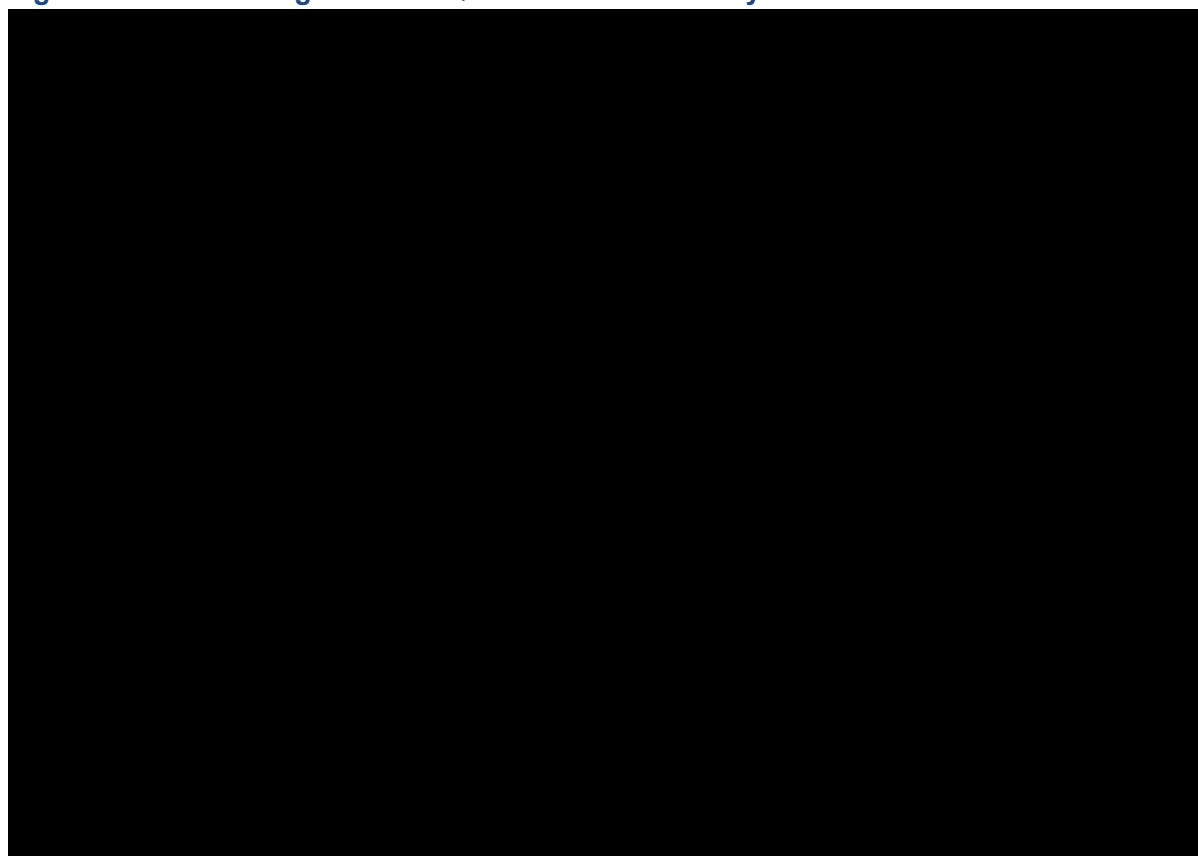

^aIndividual graphs for KCCQ domain including KCCQ-TSS (Panel A), KCCQ-PLS (Panel B), KCCQ-CSS (Panel C) and KCCQ-OSS (Panel D); ^bTSS quantifies the symptom frequency and severity, PLS evaluates the physical function, CSS includes the symptoms and physical function domains, and OSS summarises all key domains

(TSS, physical function, quality of life and social function). Scores are transformed to a range of 0–100, in which higher scores reflect better health status.

Source: AstraZeneca UK Ltd. Data on File.⁹³

Abbreviations: CSS: Clinical Summary Score; Dapa: dapagliflozin; OSS, Overall Summary Score; PLS: Physical Limitation Score; TSS: Total Symptom Score; wk: week.

The results of the responder analysis showed that [REDACTED] in the dapagliflozin group compared with the placebo group [REDACTED] by [REDACTED], which is the clinically significant improvement threshold.⁹³ A [REDACTED] of patients in the dapagliflozin group compared with the placebo group had at least small ([REDACTED]), moderate ([REDACTED]), and large ([REDACTED]) [REDACTED] in KCCQ-TSS, PLS, CSS and OSS with all comparisons being statistically significant, except 15 point or greater improvement in KCCQ-TSS and 5 point or greater improvement in OSS; (Figure 12).⁹³

Figure 12: Responder analyses of clinically meaningful change in KCCQ domains at 8 months with dapagliflozin versus placebo^a

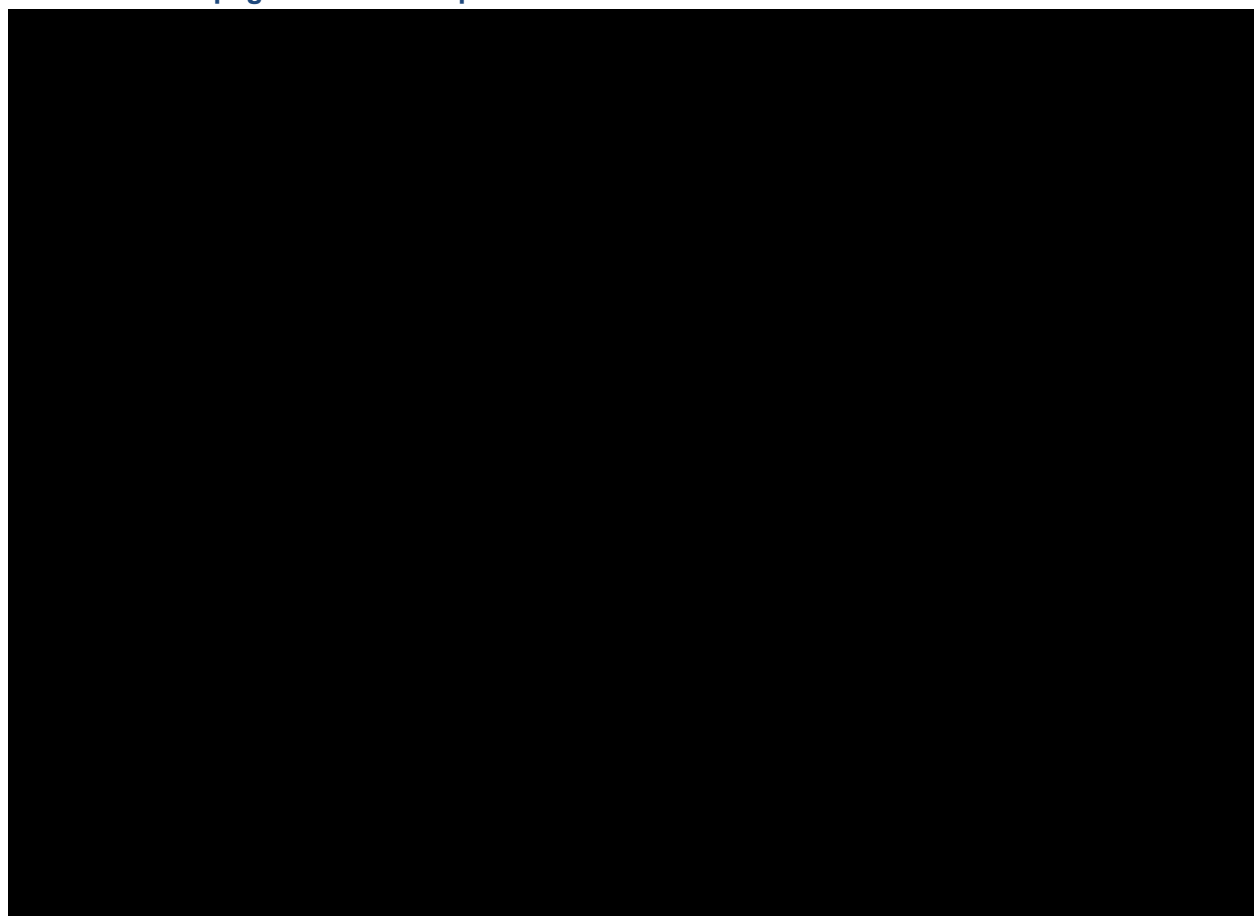

^aResponder analyses of clinically meaningful changes in KCCQ-TSS (Panel A), KCCQ-PLS (Panel B), KCCQ-CSS (Panel C) and KCCQ-OSS (Panel D).

Source: AstraZeneca UK Ltd. Data on File.⁹³

Abbreviations: CSS: Clinical Summary Score; Dapa: dapagliflozin; OR, odds ratio; OSS: Overall Summary Score; PLS: Physical Limitation Score; TSS: Total Symptom Score.

B.2.6.3. Exploratory endpoints

Exploratory outcomes, including time to first occurrence of hospitalisation from any cause, proportion of patients with worsened NYHA class from baseline to 8 months, and EQ-5D-5L analysis are presented in detail below. Other exploratory outcomes, including change in eGFR, body weight and systolic blood pressure from baseline, are presented in Appendix M, while the KCCQ clinical and overall scores, and domains are presented in Section B.2.6.2.

Company evidence submission template for dapagliflozin for treating chronic heart failure with preserved or mildly reduced ejection fraction [ID1648]

Hospitalisation from any cause

All-cause hospitalisation was reduced in patients treated with dapagliflozin compared with placebo although the difference was [REDACTED]

Occurrence of hospitalisation from any cause is presented in Table 15. In the dapagliflozin group, [REDACTED] of patients ([REDACTED] patients) had an occurrence of hospitalisation from any cause compared with [REDACTED] patients) in the placebo group.⁷⁸

Table 15: Analysis of first occurrence of hospitalisation from any cause in DELIVER

Variable	Dapagliflozin (N=3,131)		Placebo (N=3,132)		Dapagliflozin versus placebo		
	Subjects with event, n (%)	Event rate ^a	Subjects with event, n (%)	Event rate ^a	HR ^b	95% CI	p-value
Hospitalisation from any cause	[REDACTED]	[REDACTED]	[REDACTED]	[REDACTED]	[REDACTED]	[REDACTED]	[REDACTED]

Source: DELIVER CSR.⁷⁸

Abbreviations: CI: Confidence interval; HR: hazard ratio; N: Number of patients in treatment group; T2DM: type 2 diabetes mellitus.

Proportion of patients with worsened NYHA class from baseline to 8 months

Dapagliflozin provided early (4 weeks) and sustained net improvement in NYHA functional class through to Week 32 versus placebo⁸⁹

The effect of dapagliflozin versus placebo on NYHA functional class over time is presented in Table 16.⁸⁹ Any improvements in NYHA class were experienced more often by patients on dapagliflozin than those on placebo by Week 4 (11.0% versus 8.7%), Week 16 (15.8% versus 13.2%) and Week 32 (18.7% versus 14.5%).⁸⁹ Also, dapagliflozin, at Weeks 4, 16 and 32, was associated with a lower likelihood of NYHA class deterioration.⁸⁹ There was a higher likelihood in patients treated with dapagliflozin versus placebo to experience an improvement rather than a worsening in NYHA class at Week 4 (OR 1.37, 95% CI: 1.17–1.60; p<0.001), Week 16 (OR 1.20, 95% CI: 1.05–1.38; p=0.007) through to Week 32 (OR 1.32, 95% CI: 1.16–1.51; p<0.001).⁸⁹

Table 16: Effect of dapagliflozin versus placebo on NYHA functional class over time^a

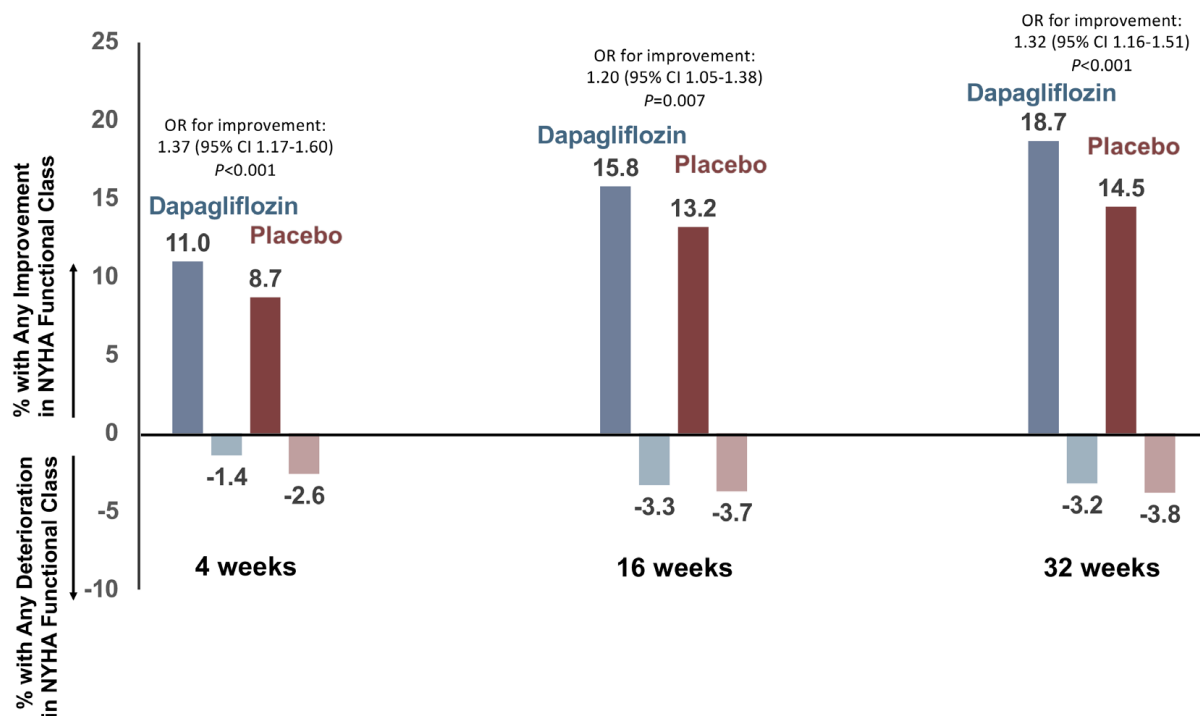

^aValues displayed as percentage of participants with any improvement or deterioration in NYHA functional class. Odds ratios (OR) represent OR for improvement rather than worsening NYHA functional class at each timepoint. Source: Ostrominski *et al.* (2022).⁸⁹

Abbreviations: CI: confidence interval; NYHA: New York Heart Association; OR: odds ratio.

EQ-5D-5L

In DELIVER, [REDACTED], as estimated from EQ-5D-5L data [REDACTED]
 [REDACTED]
 [REDACTED]
 [REDACTED]

B.2.7. Subgroup analysis

Pre-planned subgroup analyses of the primary efficacy outcomes in DELIVER are presented in Figure 13. The benefit of dapagliflozin on the primary composite endpoint was consistent across the key prespecified subgroups, including age, sex and those defined by baseline LVEF ($\leq 49\%$, $50\%–59\%$, $\geq 60\%$), with no attenuation of treatment observed in patients with greater LVEF of $50\%–59\%$ and $\geq 60\%$ (Figure 13).⁷⁶

Baseline characteristics of patients in the DELIVER trial are described in Section B.2.3.2 with statistical methods summarised in B.2.4.

Figure 13: Forest plot of the primary composite endpoint (CV mortality and HF events) by subgroups in DELIVER

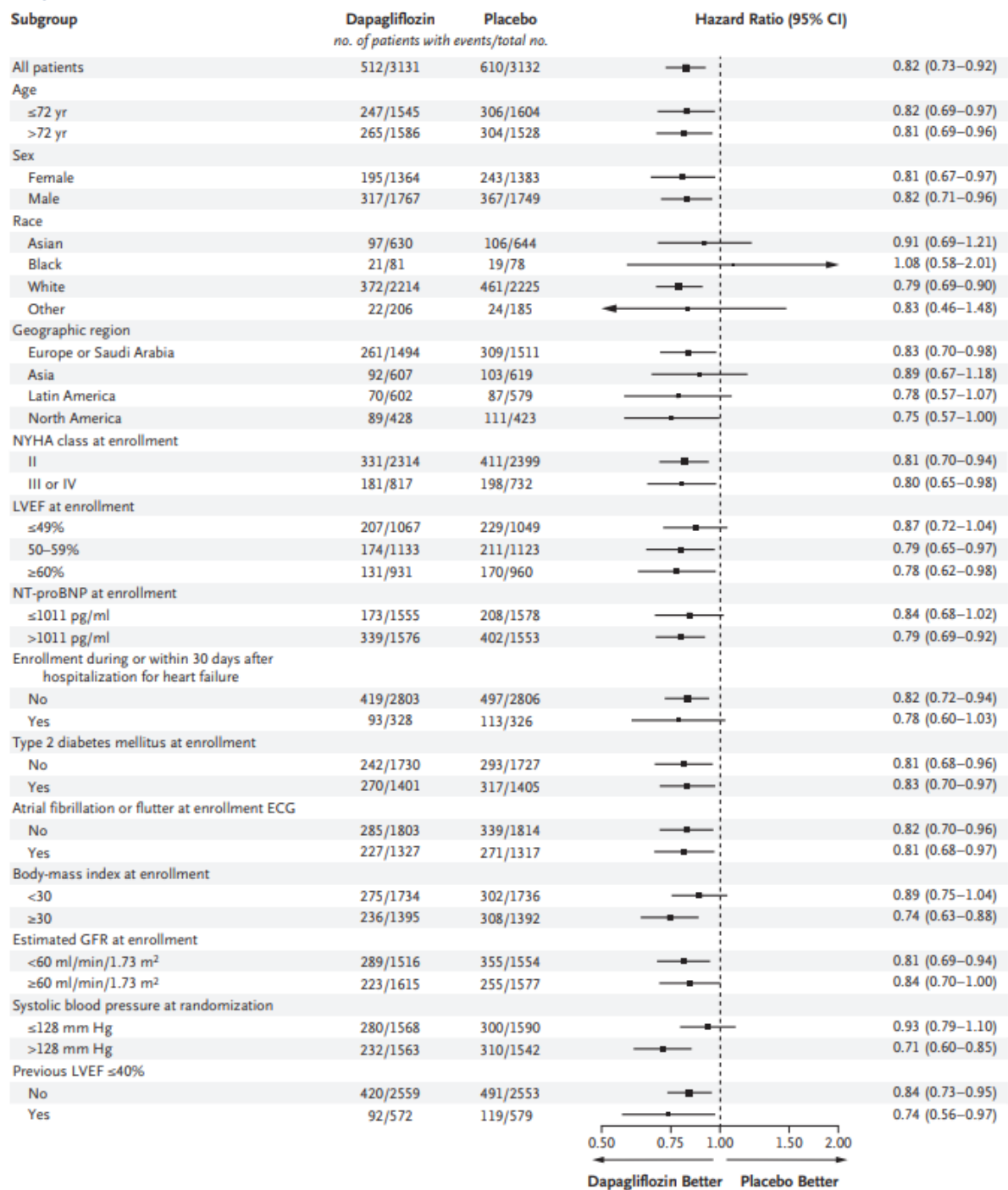

The primary outcome was a composite of worsening heart failure, which was defined as either an unplanned HHF or an UHFV, or cardiovascular mortality. Race was reported by the investigators. The size of the boxes is proportional to the number of patients in the subgroup, and arrows on the CI bars indicate that the upper or lower boundary of the confidence interval is off the scale. One patient in the placebo group who had NYHA class I disease at baseline was not included in the analysis of NYHA class at enrolment.

Source: Solomon *et al.* (2022).⁷⁶

Abbreviations: CI: confidence interval; CV: cardiovascular; Dapa: dapagliflozin; ECG: echocardiogram; eGFR: estimated glomerular filtration rate; HF: heart failure; HHF: hospitalisation for heart failure; HR: hazard ratio; LVEF: left ventricular ejection fraction; N: number of patients in treatment group; N#: number of patients in the subgroup; n: number of patients with event; NT-proBNP: N-terminal pro b-type natriuretic peptide; NYHA: New York Heart Association; SBP: systolic blood pressure.

Patients with HFimpEF

In this previously unstudied patient subpopulation, a total of [REDACTED] of patients enrolled in DELIVER had HFimpEF (prior LVEF $\leq 40\%$) and a prespecified analysis was conducted to investigate the efficacy of dapagliflozin in this subgroup of patients.^{78, 79} Overall, event rates were similar in those with HFimpEF compared with patients with HF and an LVEF consistently $>40\%$.⁷⁶ Treatment with dapagliflozin reduced the primary composite outcome in participants with HFimpEF (HR 0.74, 95% CI: 0.56, 0.97, [REDACTED]) to a similar extent as in those with HF and an LVEF consistently over 40% (HR 0.84, 95% CI: 0.73, 0.95, [REDACTED]; p-interaction=[REDACTED]) (Table 17).^{76, 79} Similarly, [REDACTED] was observed between those with HFimpEF and those with HF and an LVEF $>40\%$ prior to enrolment in all other secondary outcomes.⁷⁹

Table 17: Primary composite endpoint (CV mortality and HF events) in patients with HFimpEF compared with those with HF and an LVEF consistently $>40\%$

	HFimpEF (N=[REDACTED])	HF and an LVEF consistently $>40\%$ (N=[REDACTED])	p-value for interaction
Events	[REDACTED]	[REDACTED]	[REDACTED]
Event rate ^a	[REDACTED]	[REDACTED]	
HR, 95% CI	0.74 (0.56, 0.97)	0.84 (0.73, 0.95)	
P-value	[REDACTED]	[REDACTED]	

^a Per 100 patient years.

Source: AstraZeneca UK Ltd. Data on File;⁷⁹ Solomon *et al.* (2022).⁷⁶

Abbreviations: CI: confidence interval; CV: cardiovascular; Dapa: dapagliflozin; HF: heart failure; HR: hazard ratio; LVEF: left ventricular ejection fraction; N: number of patients in treatment group; py: patient year.

B.2.8. Prespecified analysis: estimated benefits with long-term treatment with dapagliflozin

The following section provides an overview of a prespecified analysis conducted to estimate the long-term benefits of treatment with dapagliflozin in patients with HF and an LVEF $>40\%$.⁸⁷

B.2.8.1. Objectives

To investigate the expected long-term benefits of dapagliflozin in patients with HF and an LVEF $>40\%$ beyond the timelines of the DELIVER trial.⁸⁷

B.2.8.2. Summary of methodology

In this prespecified analysis, validated nonparametric age-based methods were used to extrapolate potential gains in event-free survival from the primary endpoint (composite of CV mortality and HF events) from the long-term use of dapagliflozin in patients with HF and an LVEF $>40\%$.⁸⁷ Projected event-free survival using age at randomisation instead of time from randomisation as the time horizon, was estimated for every year between the ages of 55 and 85 years.⁸⁷ For each year of age in both treatment arms, the residual life span free from the primary endpoint was estimated based on area under the survival curve, up to a maximum of 100 years.⁸⁷

B.2.8.3. Summary of results

A total of 1,122 events of the primary endpoint occurred over the median follow-up period of 2.3 years with an incidence rate of 8.7 (95% CI: 8.2, 9.2) per 100 patient-years.⁸⁷ Treatment gains in event-free survival from the primary endpoint for dapagliflozin versus placebo were 2.0 years (95% CI: -0.6, 4.6; p=0.14) at age 55 years, 2.3 years (95% CI: 0.9, 3.8; p=0.002) years at age 65 years (p=0.002), and 1.2 years (95% CI: -0.1, 2.4; p=0.063) at age 75 years.⁸⁷

At age 65 years, event-free survival was greater with dapagliflozin than placebo across relevant subgroups examined. Treatment with dapagliflozin may extend event-free survival by 1.2 to 2.3 years for patients aged 55 years and older with HF and an LVEF >40%.⁸⁷

B.2.9. Meta-analysis

DELIVER was not powered to test the effect of dapagliflozin on the individual components of the composite primary outcome or important secondary outcomes.⁷⁶ In order to examine the effects of dapagliflozin on key clinical outcomes in patients with HF across the full continuum of LVEF, a pooled analysis of the DELIVER and DAPA-HF trials was planned prior to DELIVER database lock, then conducted and published recently.⁹⁴ The population evaluated in this analysis is aligned with the anticipated update to the existing marketing authorisation for dapagliflozin for the treatment of chronic HF with LVEF ≤40%, [REDACTED]

Summary of the pooled analysis

- The pooled analysis (N=11,007) was a patient-level pooled meta-analysis of DELIVER and DAPA-HF (the pivotal RCT for dapagliflozin in addition to SoC versus placebo in addition to SoC in patients with HF and an LVEF ≤40%), and thus covered the full population of patients with HF irrespective of LVEF⁹⁴
- In the pooled analysis of patients with HF irrespective of LVEF, dapagliflozin compared with placebo significantly:⁹⁴
 - Reduced the risk of mortality from CV causes (HR 0.86, 95% CI: 0.76, 0.97; p=0.01)
 - Reduced the risk of mortality from any causes (HR 0.90, 95% CI: 0.82, 0.99; p=0.03)
 - Reduced total hospital admissions for HF (RR 0.71, 95% CI: 0.65, 0.78; p<0.001)
 - Reduced major adverse cardiovascular events (MACE; HR 0.90, 95% CI: 0.81, 1.00; p=0.045)
- The results of this pooled analysis therefore support the benefits of dapagliflozin in the full HF population, irrespective of LVEF⁹⁴

B.2.9.1. Summary of methodology

The pooled analysis was a patient-level pooled meta-analysis of DELIVER and DAPA-HF to evaluate the efficacy of dapagliflozin across the full continuum of LVEF in patients with HF.⁹⁴ The pooled analysis was prespecified to examine the effect of treatment with dapagliflozin on endpoints which neither trial was sufficiently powered for. While both trials enrolled patients with diagnosed HF, functional limitation, and elevated natriuretic peptides, the main difference between the trials was that DAPA-HF enrolled patients with HF and an LVEF ≤40% whereas

DELIVER enrolled those with HF and an LVEF >40%.⁹⁴ In each trial, patients were randomised to receive either dapagliflozin 10mg once daily, or a matching placebo, in addition to SoC.⁹⁴ Both trials were event driven and used the primary composite endpoint of CV mortality, and HF events.⁹⁴

The pooled analysis included the following endpoints:⁹⁴

- CV mortality;
- Mortality from any cause;
- Total hospital admissions for HF;
- Composite of CV mortality, MI or stroke (“major adverse cardiovascular events” [MACE]).

B.2.9.2. Results

A total of 11,007 participants were included in the analysis.⁹⁴ Of these, 4,744 had HF and an LVEF ≤40% and 6,263 had HF and an LVEF >40%, with 5,503 randomised to placebo and 5,504 to dapagliflozin. The median LVEF was 44% (IQR: 34, 55).⁹⁴

Baseline characteristics

Baseline characteristics for the patients included in the pooled analysis are presented in Table 18. Patients with a higher LVEF were older, more likely to be female, had higher blood pressure and a higher BMI than those with a lower LVEF.⁹⁴ It was more common for those with higher LVEF to have had a history of hypertension and AF than those with lower LVEF.⁹⁴ On the contrary, it was less common for those with higher LVEF to have had a history of MI than those with lower LVEF.⁹⁴ There was a lower proportion of patients in NYHA class III/IV amongst patients with higher LVEF. KCCQ scores were better in patients with lower LVEF than in those with higher LVEF.⁹⁴ NT-proBNP and eGFR levels were lower amongst patients with higher LVEF, as was the use of ACEis, ARBs, sacubitril/valsartan, beta-blockers, MRAs and ICDs.⁹⁴

Table 18: Baseline characteristics of the patients included in the pooled analysis of DELIVER and DAPA-HF by LVEF category

	LVEF category						p-value for trend
	≤30%	>30–≤37%	>37–≤44%	>44–≤51%	>51–≤60%	>60%	
	N=2,161	N=1,584	N=1,863	N=1,862	N=2,142	N=1,395	
Baseline LVEF(%)	24.9±4.7	34.4±1.8	40.6±1.9	47.7±2.2	56.4±2.7	66.6±4.6	
Randomised treatment							0.27
Placebo	1,099 (50.9%)	785 (49.6%)	900 (48.3%)	947 (50.9%)	1,054 (49.2%)	718 (51.5%)	
Dapagliflozin	1,062 (49.1%)	799 (50.4%)	963 (51.7%)	915 (49.1%)	1,088 (50.8%)	677 (48.5%)	
Age	65±11	67±11	69±10	70±10	73±9	74±9	<0.001
Sex							<0.001
Female	445 (20.6%)	379 (23.9%)	528 (28.3%)	667 (35.8%)	1,053 (49.2%)	784 (56.2%)	
Male	1,716 (79.4%)	1,205 (76.1%)	1,335 (71.7%)	1,195 (64.2%)	1,089 (50.8%)	611 (43.8%)	
Region							<0.001
Europe and Saudi Arabia	804 (37.2%)	757 (47.8%)	1,017 (54.6%)	1,060 (56.9%)	1,075 (50.2%)	446 (32.0%)	
North America	381 (17.6%)	195 (12.3%)	162 (8.7%)	210 (11.3%)	360 (16.8%)	220 (15.8%)	
South America	431 (19.9%)	271 (17.1%)	315 (16.9%)	310 (16.6%)	318 (14.8%)	353 (25.3%)	
Asia/Pacific	545 (25.2%)	361 (22.8%)	369 (19.8%)	282 (15.1%)	389 (18.2%)	376 (27.0%)	
Race							<0.001
White	1,423 (65.8%)	1,133 (71.5%)	1,387 (74.4%)	1,442 (77.4%)	1,554 (72.5%)	833 (59.7%)	
Asian	554 (25.6%)	367 (23.2%)	379 (20.3%)	293 (15.7%)	404 (18.9%)	393 (28.2%)	
Black or African American	147 (6.8%)	59 (3.7%)	33 (1.8%)	42 (2.3%)	59 (2.8%)	45 (3.2%)	
Other	37 (1.7%)	25 (1.6%)	64 (3.4%)	85 (4.6%)	125 (5.8%)	124 (8.9%)	
Baseline pulse (beats/min)	72±12	71±12	71±11	72±12	72±12	71±12	0.047
Baseline systolic blood pressure (mmHg)	118±15	124±17	126±15	128±15	129±15	129±15	<0.001
Baseline diastolic blood pressure (mmHg)	72±10	74±11	75±10	75±10	74±11	73±10	0.002
Baseline BMI	28±6	28±6	29±6	30±6	30±6	30±6	<0.001
History of hypertension	1,463 (67.7%)	1,221 (77.1%)	1,565 (84.0%)	1,646 (88.4%)	1,937 (90.4%)	1,244 (89.2%)	<0.001
History of T2DM	885 (41.0%)	661 (41.7%)	838 (45.0%)	844 (45.3%)	952 (44.4%)	609 (43.7%)	0.16

	LVEF category						p-value for trend
	≤30%	>30–≤37%	>37–≤44%	>44–≤51%	>51–≤60%	>60%	
	N=2,161	N=1,584	N=1,863	N=1,862	N=2,142	N=1,395	
History of stroke	207 (9.6%)	149 (9.4%)	184 (9.9%)	166 (8.9%)	236 (11.0%)	121 (8.7%)	0.19
History of MI	940 (43.5%)	704 (44.4%)	799 (42.9%)	635 (34.1%)	449 (21.0%)	204 (14.6%)	<0.001
History of AF	736 (34.1%)	635 (40.1%)	811 (43.5%)	1,014 (54.5%)	1,291 (60.3%)	796 (57.1%)	<0.001
Prior HHF	1,063 (49.2%)	735 (46.4%)	860 (46.2%)	835 (44.8%)	843 (39.4%)	454 (32.5%)	<0.001
Baseline NYHA II or III/IV							<0.001
II	1,466 (67.8%)	1,065 (67.2%)	1,277 (68.5%)	1,369 (73.5%)	1,641 (76.6%)	1,098 (78.8%)	
III/IV	695 (32.2%)	519 (32.8%)	586 (31.5%)	493 (26.5%)	501 (23.4%)	296 (21.2%)	
Baseline KCCQ-TSS	78 (59-93)	78 (59-92)	75 (57-91)	74 (56-90)	71 (54-86)	73 (54-88)	<0.001
Baseline NT-proBNP (ng/L)	1,680 (964-3163)	1,309 (805-2362)	1,225 (714-2225)	1,089 (653-1877)	976 (632-1631)	903 (542-1548)	<0.001
Baseline eGFR (mL/min/1.73m ²)	66±20	66±20	64±19	62±19	60±18	59±19	<0.001
Baseline creatinine (umol/L)	106±31	104±30	103±30	103±31	102±31	101±32	<0.001
Diuretics	1,876 (86.8%)	1,312 (82.8%)	1,565 (84.0%)	1,645 (88.3%)	1,952 (91.1%)	1,238 (88.7%)	<0.001
ACEi or ARB	1,714 (79.3%)	1,339 (84.5%)	1,516 (81.4%)	1,381 (74.2%)	1,549 (72.3%)	996 (71.4%)	<0.001
ARNI	306 (14.2%)	153 (9.7%)	162 (8.7%)	107 (5.7%)	60 (2.8%)	21 (1.5%)	<0.001
ACEi or ARB or ARNI	2,009 (93.0%)	1,488 (93.9%)	1,671 (89.7%)	1,483 (79.6%)	1,606 (75.0%)	1,017 (72.9%)	<0.001
Beta-blocker	2,079 (96.2%)	1,529 (96.5%)	1,689 (90.7%)	1,617 (86.8%)	1,741 (81.3%)	1,080 (77.4%)	<0.001
MRA	1,610 (74.5%)	1,124 (71.0%)	1,149 (61.7%)	853 (45.8%)	821 (38.3%)	480 (34.4%)	<0.001
Digitalis	472 (21.8%)	273 (17.2%)	185 (9.9%)	89 (4.8%)	106 (4.9%)	58 (4.2%)	<0.001
CRT-D or CRT-P	202 (9.3%)	104 (6.6%)	68 (3.7%)	43 (2.3%)	31 (1.4%)	6 (0.4%)	0.002
CRT-D or ICD	772 (35.7)	329 (20.8)	187 (10.0)	74 (4.0%)	39 (1.8%)	9 (0.6%)	<0.001

Source: Jhund *et al.* (2022).⁹⁴

Abbreviations: ACE: angiotensin-converting enzyme; ARB: angiotensin receptor blocker; ARNI: angiotensin receptor neprilysin inhibitor; AF: atrial fibrillation; BMI: body mass index; CRT-D: cardiac resynchronisation therapy – defibrillator; CRT-P: cardiac resynchronisation therapy – pacemaker; eGFR: estimated glomerular filtration rate; HHF: hospitalisation for heart failure; ICD: implantable cardioverter defibrillator; KCCQ-TSS: Kansas City Cardiomyopathy Questionnaire – Total Symptom Score; LVEF: left ventricular ejection fraction; MI: myocardial infarction; MRA: mineralocorticoid receptor antagonist; NT-proBNP: N-terminal pro-brain natriuretic peptide; NYHA: New York Heart Association; T2DM: Type 2 diabetes mellitus

Outcomes

In the pooled analysis of DELIVER and DAPA-HF, dapagliflozin significantly reduced the risk of mortality and HHF versus placebo for patients with HF irrespective of LVEF⁹⁴

The rate of each prespecified outcome was lower in the dapagliflozin group compared with the placebo group as shown on Figure 14.⁹⁴ Dapagliflozin compared with placebo reduced the risk of mortality from CV causes (HR 0.86, 95% CI: 0.76, 0.97; $p=0.01$), the risk of mortality from any cause (HR 0.90, 95% CI: 0.82, 0.99; $p=0.03$), total HHF (RR 0.71, 95% CI: 0.65, 0.78; $p<0.001$), and MACE (HR 0.90, 95% CI: 0.81, 1.00; $p=0.045$).⁹⁴

Figure 14: Effect of dapagliflozin on key clinical outcomes in pooled DAPA-HF and DELIVER dataset

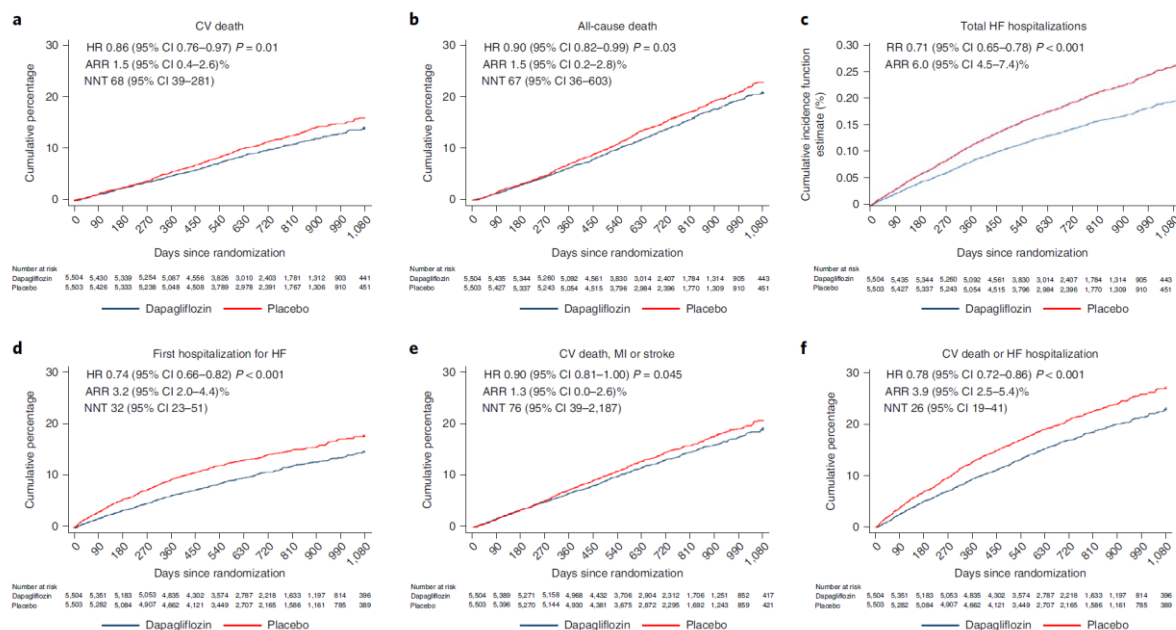

^{a-f}Incidence of: death from CV causes (a); death from all causes (b); the total number of hospital admissions for HF (c); time to first hospital admission for HF (d); death from CV causes, MI or stroke (e); and death from CV causes or hospital admission for HF (f), according to randomised therapy. Participants randomised to dapagliflozin are shown in blue and those randomised to placebo in red. All figures are Kaplan–Meier curves with an HR and 95% CI estimated from Cox’s model with two-sided p-values except for the total number of hospital admissions for HF, which was plotted using the Gosh and Lin method accounting for death from CV causes (the RR is estimated from the joint frailty model with a two-sided p-value). No adjustment for multiple comparisons was made. NNT indicates the number of patients who need to be treated over the median duration of follow-up to prevent one event (of the type in each panel). An NNT could not be calculated for the total number of hospital admissions for HF because this was an episode-based rather than a patient-based analysis (that is, patients may have had more than one hospital admission). ARR and NNTs are shown with a 95% CI.

Source: Jhund *et al.* (2022).⁹⁴

Abbreviations: ACE: angiotensin-converting enzyme; ARB: angiotensin receptor blocker; ARNI: angiotensin receptor neprilysin inhibitor; ARR: absolute risk reduction; CI: confidence interval; CV: cardiovascular; ICD: implantable cardioverter defibrillator; HF: heart failure; HR: hazard ratio; MI: myocardial infarction; MR: mineralocorticoid receptor antagonist; NNT: number needed to treat; RR: rate ratio.

Figure 15: Effect of randomised treatment on CV mortality according to the prespecified subgroups^a

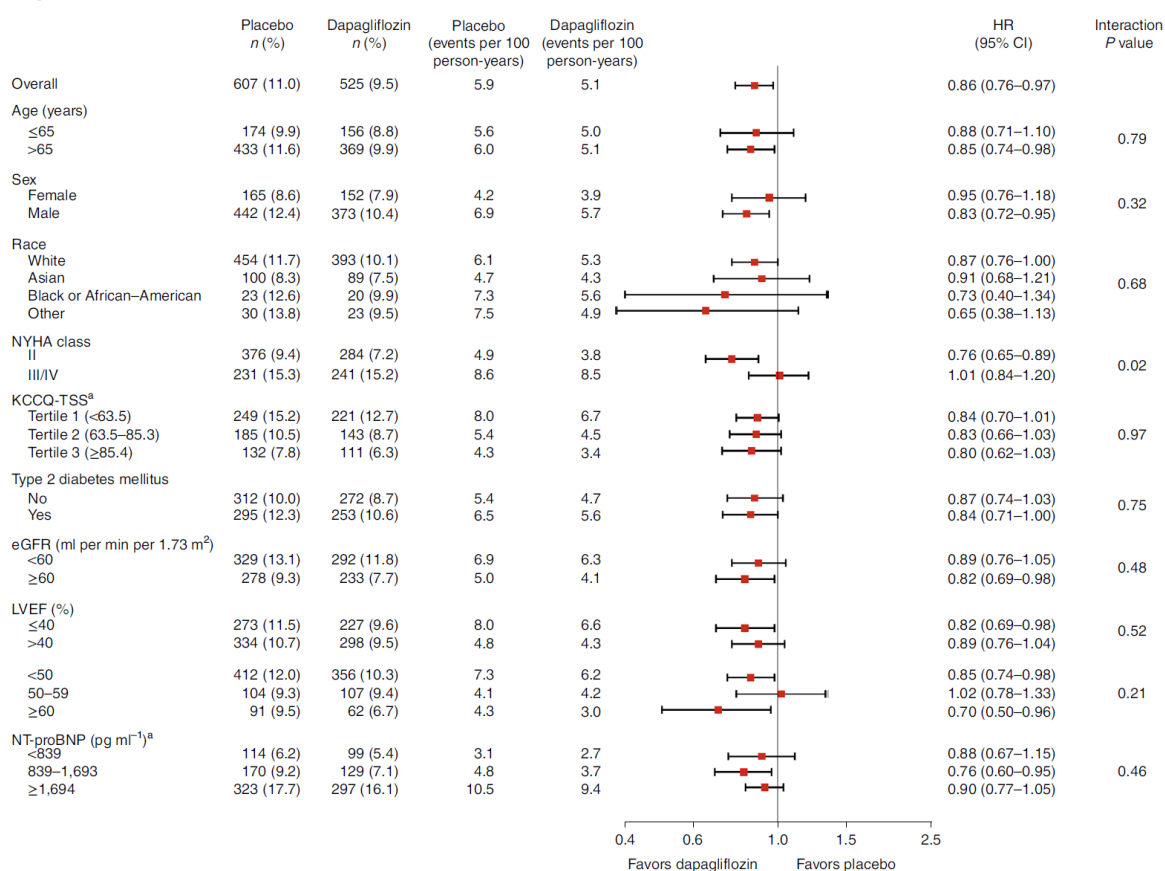

^aEstimates are HRs with error bars representing 95% CIs from Cox’s model and a two-sided p-value for interaction from Wald’s test of Cox’s model. No adjustment for multiple comparisons was made. ^aNot a prespecified subgroup.

Source: Jhund *et al.* (2022).⁹⁴

Abbreviations: BMI: body mass index; CI: confidence interval; CV: cardiovascular; Dapa: dapagliflozin; ECG: echocardiogram; eGFR: estimated glomerular filtration rate; HF: heart failure; HR: hazard ratio; LVEF: left ventricular ejection fraction; N: number of patients in treatment group; N#: number of patients in the subgroup; n: number of patients with event; NT-proBNP: N-terminal pro b-type natriuretic peptide; NYHA: New York Heart Association; SBP: systolic blood pressure; T2DM: type 2 diabetes mellitus.

B.2.10. Indirect and mixed treatment comparisons

Indirect and mixed treatment comparisons were not required as the relevant comparator, namely placebo in addition to SoC for patients with HF and an LVEF >40%, was included in the pivotal RCT DELIVER.⁷⁶

B.2.11. PRESERVED-HF trial outcome summary

PRESERVED-HF supports that dapagliflozin significantly improved patient-reported symptoms and physical limitations in patients with HF and an LVEF ≥45% as well as being generally well tolerated.⁸¹ Although PRESERVED-HF was not used to populate the economic model due to the reasons presented in Section B.2.2, it is presented for completeness as the outcomes observed in the trial were consistent with those from DELIVER.

B.2.11.1. Summary of trial methodology

PRESERVED-HF was a randomised, double-blind, placebo-controlled, multicentre Phase IV

Company evidence submission template for dapagliflozin for treating chronic heart failure with preserved or mildly reduced ejection fraction [ID1648]

study in patients with HF and an LVEF $\geq 45\%$, evaluating the effect of dapagliflozin 10 mg versus placebo, given once daily in addition to background regional SoC, including treatments for co-morbidities, on disease-specific biomarkers (NT-proBNP and BNP), symptoms, health status, and QoL.⁸¹ The methodology of PRESERVED-HF is summarised in Table 19.

Table 19: Summary of trial methodology: PRESERVED-HF

Parameter	Description
Study objective	To evaluate the impact of dapagliflozin, as compared with placebo, on HF, disease specific biomarkers, symptoms, health status and quality of life in patients with chronic HF and an LVEF $\geq 45\%$.
Trial design	Randomised, double-blind, placebo-controlled, multicentre Phase IV study.
Duration of study	The study duration was of 12 weeks.
Eligibility criteria for participants	<p>Inclusion criteria:</p> <ol style="list-style-type: none"> Age >18 and <120 at the screening visit. Symptoms of dyspnoea (NYHA class II-IV) without evidence of a non-cardiac or ischemic explanation for dyspnoea. EF $\geq 45\%$ as determined on imaging study within 24 months of enrolment with no change in clinical status suggesting potential for deterioration in systolic function. Elevated NT-proBNP (≥ 225 pg/ml) or BNP (≥ 75 pg/ml)^a Stable medical therapy for heart failure for 15 days as defined by: <ul style="list-style-type: none"> No addition or removal of ACEis, ARBs, ARNI, beta-blockers, CCBs or aldosterone antagonists No substantial change in dosage (100% or greater increase or decrease from baseline dose) of ACE, ARBs, beta-blockers, CCBs or aldosterone antagonists On a diuretic ≥ 15 days prior to screening visit and a stable diuretic therapy for 7 days At least one of the following: <ul style="list-style-type: none"> Hospitalisation for decompensated HF in the last 12 months Acute treatment for HF with intravenous loop diuretic or hemofiltration in the last 12 months Mean pulmonary capillary wedge pressure ≥ 15 mmHg LVEDP ≥ 15 mmHg documented during catheterisation at rest, or pulmonary capillary wedge pressure or LVEDP ≥ 25 mmHg documented during catheterisation with exercise. Structural heart disease evidenced by at least one of the following echo findings (any local measurement made within the 24 months prior to screening visit): <ul style="list-style-type: none"> 1) LA enlargement defined by at least one of the following: LA width ≥ 3.8cm or LA length ≥ 5.0 cm or LA area ≥ 20 cm² or LA volume ≥ 55 mL or LA volume index ≥ 29 mL/m² 2) OR LVH defined by septal thickness or posterior wall thickness ≥ 1.1 cm. <p>Exclusion criteria</p> <ol style="list-style-type: none"> Decompensated HF (HHF within 7 days prior to screening). History of type 1 diabetes. History of DKA.

Parameter	Description
	<ol style="list-style-type: none"> 4. eGFR <20 at the screening visit by modified MDRD equation $GFR (mL/min/1.73 m^2) = 175 \times (SCr)^{-1.154} \times (Age)^{-0.203} \times (0.742 \text{ if female}) \times (1.210 \text{ if African American})$. 5. Admission for an acute coronary syndrome (STEMI, NSTEMI, or unstable angina), PCI, or cardiac surgery within 30 days prior to the screening visit. 6. Admission for CRT within 90 days prior to the screening visit. 7. Planned CV revascularisation (percutaneous intervention or surgical) or major cardiac surgery (CABG), valve replacement, ventricular assist device, cardiac transplantation, or any other surgery requiring thoracotomy, or transcatheter aortic valve replacement) or CRT within the 90 days after the screening visit. 8. Participation in any interventional clinical trial (with an investigational drug or device) that is not an observational registry within 15 days of the screening visit. 9. History of hypersensitivity to dapagliflozin. 10. For women of child-bearing potential: Current or planned pregnancy or currently lactating. Women of childbearing potential are defined as any female who has experienced menarche and who is NOT permanently sterile or postmenopausal. Post-menopausal is defined as 12 consecutive months with no menses without an alternative medical cause. Women of child-bearing potential, who are sexually active, must agree to use a medically-accepted method of birth control for the duration of the study. Acceptable birth control methods include: (1) surgical sterilisation (such as a hysterectomy or bilateral tubal ligation), (2) progesterone hormonal contraceptives (birth control pills or implants), (3) barrier methods (such as a condom or diaphragm) used with a spermicide, or (4) an IUD. Women of child-bearing potential will have a urine pregnancy test at every clinic visit and it must be negative to continue study participation. 11. Life expectancy <1 year at the screening visit. 12. Patients who are volume depleted based upon physical examination at the time of the screening or randomisation visit. 13. BNP <75 pg/mL and NT-proBNP<225 pg/mL at the screening visit.^b 14. Patients currently being treated with any SGLT2 inhibitor (dapagliflozin, canagliflozin, empagliflozin, ertugliflozin) or having received treatment with any SGLT2 inhibitor within the 12 weeks prior to the screening visit. 15. Average supine SBP <100 mmHg at the screening or randomisation visit. 16. Current history of bladder cancer. 17. Donation of blood or bone marrow 12 weeks prior to the screening visit and no planned donations during the study period. 18. HF due to restrictive/infiltrative cardiomyopathy, active myocarditis, constrictive pericarditis, severe stenotic valve disease, and HOCM. 19. HF due to severe aortic or mitral regurgitation. 20. Severe COPD thought to be a primary contributor to dyspnoea. 21. Isolated right HF due to pulmonary disease. 22. Active and significant ischemia thought to be a primary contributor to dyspnoea.

Parameter	Description
	<p>23. Documentation of previous EF <45%, under stable conditions, within the past 36 months.</p> <p>24. Complex congenital heart disease.</p> <p>25. Uncontrolled hypertension, defined as systolic blood pressure \geq200 mmHg during the screening visit (average value of three blood pressure measurements obtained in supine position).</p> <p>26. Any other condition that in the judgment of the investigator would jeopardise the patient's participation in the study or that may interfere with the interpretation of study data or if the patient is considered unlikely to comply with study procedures, restrictions and requirements.</p> <p>27. Bariatric surgery within the past 6 months or planned bariatric surgery within the study time course.</p> <p>28. CardioMems device implantation within previous 4 weeks or planned CardioMems implantation during study period.</p> <p>29. For echo substudy only: patients with ventricular paced rhythm or left bundle branch block on the most recent clinically available 12-lead electrocardiogram.</p> <p>30. For echo substudy only: permanent atrial fibrillation.</p>
Settings and locations where the data were collected	26 sites across the United States
Trial drugs	<ul style="list-style-type: none"> • Dapagliflozin 10 mg oral once daily plus SoC (N=162) • Placebo plus SoC (N=162)
Primary outcomes	Change from baseline in HF related health status using the KCCQ-CSS at 12 weeks.
Secondary outcomes	<ul style="list-style-type: none"> • Change from baseline in HF related health status using the KCCQ-OSS at 12 weeks • Change from baseline in NT-proBNP at 6 and 12 weeks • Change from baseline in BNP at 6 and 12 weeks • Change from baseline in 6-minute walk test at 12 weeks • Change from baseline in HbA1c over the treatment period • Proportion of patients with a \geq5pts increase in KCCQ-CSS and KCCQ-OSS at 12 weeks • Proportion of patients with a \geq 20% decrease in NT-proBNP at 6 and 12 weeks • Proportion of patients with a \geq 5pts increase in KCCQ and a \geq 20% decrease in NT-proBNP at 6 and 12 weeks • Change in weight at 6 and 12 weeks • Change in systolic blood pressure at 6 and 12 weeks
Safety	<ul style="list-style-type: none"> • All cause mortality. • CV mortality. • Non-fatal MI • Stroke. • Acute kidney injury (defined as doubling of serum creatinine based on the modified RIFLE criteria). • AEs and SAEs. AEs of special interest will include DKA, volume depletion (defined as hypotension, syncope, orthostatic hypotension or dehydration), severe hypoglycaemic events and lower limb amputations.

^aFor patients with permanent atrial fibrillation inclusion thresholds will be BNP ≥ 100 pg/mL or NT-proBNP ≥ 375 pg/mL. ^bFor patients with permanent atrial fibrillation exclusion thresholds will be BNP<100 pg/mL and NT-proBNP<375pg/mL.

Sources: Nassif *et al.* (2021);⁸¹ ClinicalTrial.gov 2021 [NCT03030235].⁸⁴

Abbreviations: ACEi: angiotensin-converting enzyme inhibitor; AEs: adverse events; ARB: angiotensin receptor blockers; BNP: B-type natriuretic peptide; BP: blood pressure; CABG: coronary artery bypass grafting; CCB: calcium channel blockers; COPD : chronic obstructive pulmonary disease; CRT: cardiac resynchronisation therapy; CSS: Clinical Summary Score; CV: cardiovascular; DKA: diabetic ketoacidosis; EF: ejection fraction; (e)GFR: (estimated) glomerular filtration rate; HF: heart failure; HHF: hospitalisation for heart failure; HOCM: hypertrophic obstructive cardiomyopathy; IUD: intrauterine device; KCCQ: Kansas City Cardiomyopathy Questionnaire; LA: left atrial; LVEDP: left ventricular end diastolic pressure; LVEF: left ventricular ejection fraction; LVH: left ventricular hypertrophy; MDRD: modification of diet in renal disease; MI: myocardial infarction; N: number of patients in treatment group; NYHA: New York Heart Association; NT-proBNP: N-terminal pro B-type natriuretic peptide; OSS: Overall Summary Score; PCI: percutaneous coronary intervention; SAEs: serious adverse events; SBP: systolic blood pressure; SGLT2: sodium-glucose co-transporter-2; SoC: standard of care; (N)STEMI: (Non) ST-elevation myocardial infarction.

B.2.11.2. Baseline characteristics

Patient characteristics at baseline for patients included in PRESERVED-HF are summarised in Table 20. Overall, baseline characteristics were well balanced between the two groups.

Table 20: Characteristics of participants in PRESERVED-HF across treatment groups

Baseline characteristics	Dapagliflozin (N=162)	Placebo (N=162)
Demographics		
Median age, years (IQR)	69 (64, 77)	71 (63, 78)
Women, n (%)	92 (56.8)	92 (56.8)
White, n (%)	108 (67.1)	109 (69.0)
African American, n (%)	50 (31.1)	47 (29.7)
Medical history		
Duration of HF, years (IQR)	3.0 (1.1, 6.5)	3.2 (1.0, 6.6)
Previous HHF, n (%)	98 (60.5)	83 (51.2)
Ejection fraction %, n (%)	60 (55, 65)	60 (54, 65)
Ischemic heart disease, n (%)	32 (19.8)	31 (19.1)
T2DM, n (%)	90 (55.6)	91 (56.2)
AF, n (%)	82 (50.6)	89 (54.9)
Internal cardiac defibrillator, n (%)	7 (4.3)	9 (5.6)
Baseline HF/CV medications, n (%)		
ACEi/ARB	98 (60.5)	98 (60.5)
ARNI	2 (1.2)	3 (1.9)
Beta-blockers	119 (73.5)	116 (71.6)
Hydralazine	25 (15.4)	18 (11.1)
Long-acting nitrates	34 (21.0)	27 (16.7)
MRA	50 (30.9)	68 (42.0)
Loop diuretics	151 (93.2)	135 (83.3)
Lipid-lowering agents	132 (81.5)	127 (78.4)

Baseline characteristics	Dapagliflozin (N=162)	Placebo (N=162)
Anticoagulant agents	71 (43.8)	84 (51.9)
Physical examination		
Median BMI (IQR)	35.1 (30.4, 41.8)	34.6 (29.7, 40.4)
Median heart rate, (IQR)	70 (61, 77)	68 (62, 75)
Median systolic blood pressure, (IQR)	134 (120, 152)	132 (118, 148)
Baseline laboratory studies		
Median NT-proBNP, pg ml ⁻¹ , overall, (IQR)	641 (373, 1210)	710 (329, 1449)
Median NT-proBNP, pg ml ⁻¹ , AF, (IQR)	830 (555, 1711)	816 (481, 1687)
Median NT-proBNP, pg ml ⁻¹ , no AF, (IQR)	438 (269, 750)	485 (263, 1168)
Median BNP, pg ml ⁻¹ , overall, (IQR)	137 (81, 222)	151 (90, 254)
Median BNP, pg ml ⁻¹ , AF, (IQR)	169 (109, 255)	151 (104, 258)
Median BNP, pg ml ⁻¹ , no AF, (IQR)	107 (67, 179)	161 (77, 241)
Median eGFR, ml min ⁻¹ , (IQR)	56 (42, 69)	54 (41, 69)
Median haemoglobin A1c, %, (IQR)	6.0 (5.6, 7.3)	6.2 (5.6, 7.1)
Median haemoglobin, g dl ⁻¹ , (IQR)	12.7 (11.5, 13.9)	12.6 (11.6, 13.8)
Functional measures		
NYHA Class II, n (%)	96 (59.3%)	90 (55.6%)
NYHA Class III/IV, n (%)	65 (40.1%)	72 (44.4%)
Mean KCCQ-OSS (SD)	63.2 ± 20.4	62.3 ± 20.6
Mean KCCQ-CCS (SD)	63.4 ± 19.7	61.8 ± 20.3
Median 6MWT metres, (IQR)	244 (165, 329)	244 (154, 317)

Values are shown as absolute numbers (percentages) and median (IQR) or mean ± sd.

Sources: Nassif *et al.* (2021).⁸¹

Abbreviations: 6MWT: 6-minute walk test; ACEi: angiotensin-converting enzyme inhibitor; AF: atrial fibrillation; ARB: angiotensin receptor blockers; ARNI: angiotensin receptor neprilysin inhibitor; BMI: body mass index; CSS: Clinical Summary Score; eGFR: estimated glomerular filtration rate; HF: heart failure; HHF: hospitalisation for heart failure; IQR: interquartile range; KCCQ: Kansas City Cardiomyopathy Questionnaire; MRA: mineralocorticoid receptor antagonists; NT-proBNP: N-terminal pro B-type natriuretic peptide; NYHA: New York Heart Association; OSS: Overall Summary Score; T2DM: Type 2 diabetes mellitus.

B.2.11.3. Summary of primary and secondary efficacy outcomes

Primary endpoint: KCCQ-CS

At 12 weeks, data for the primary endpoint was available for 304 (93.8%) patients with 152 (93.8%) patients in the dapagliflozin and placebo groups, respectively. Dapagliflozin was associated with an improvement in KCCQ-CSS (difference in mean change from baseline, 5.8 points [95% CI: 2.3, 9.2], p=0.001; Table 21), which was due to improvements in symptoms (difference in mean change from baseline for KCCQ-TSS, 5.8 points [95% CI: 2.0, 9.6], p=0.003) and physical limitations (difference in mean change from baseline for KCCQ-PLS, 5.3 points [95% CI: 0.7, 10.0], p=0.026; Figure 16). Consistent subgroup results were obtained (Figure 16).⁸¹

Secondary endpoints: 6-minute walk test (6MWT), KCCQ-OS, clinically meaningful changes in KCCQ-CS and KCCQ-OSS, and changes in weight, natriuretic peptides, glycosylated hemoglobin and systolic blood pressure

At 12 weeks, data for the secondary endpoint of 6MWT were available for 291 (89.8%) patients with 148 (91.4%) patients in the dapagliflozin group and 143 (88.3%) in the placebo group.⁸¹ An improvement in 6MWT in the dapagliflozin group was observed (effect size 20.1m [95% CI 5.6, 34.7]; p=0.007; Table 21). This effect was proportionally large (8.2%) considering the baseline value of 244.4m.⁸¹

Dapagliflozin also improved KCCQ-OSS versus placebo as demonstrated with the effect size of 4.5 points (95% CI: 1.1, 7.8; p=0.009; Table 21) and was associated with a greater number of patients in the dapagliflozin group versus placebo that had a 5-point or more improvement in KCCQ-OSS (45.4% versus 34.9%; adjusted OR 1.73; 95% CI: 1.05, 2.85; p=0.03).⁸¹ Similarly, 49.4% of patients in the dapagliflozin group versus 38.2% of those in the placebo group had a 5-point or more improvement in KCCQ-CSS at 12 weeks (adjusted OR 1.64, 95% CI: 0.98, 2.75; p=0.06). Dapagliflozin was associated with greater weight loss (effect size 0.72 kg, 95% CI: 0.01, 1.42; p=0.046; Table 21).⁸¹

There were no significant differences between groups in other secondary endpoints, including NT-proBNP and BNP; proportion of patients with 20% or greater decrease in NT-proBNP; proportion of patients with both a 5-point or greater increase in KCCQ-CS and 20% or greater decrease in NT-proBNP; HbA1c; and systolic blood pressure at 12 weeks.⁸¹

Table 21: Primary and secondary endpoints at 12 weeks after treatment initiation in PRESERVED-HF

Continuous secondary endpoints ^a	Dapagliflozin (N=162)	Placebo (N=162)	Effect size	P-value
KCCQ-CSS, mean ^b	68.6 (66.2, 71.0)	62.8 (60.4, 65.3)	5.8 (2.3, 9.2)	0.001
KCCQ-OSS, mean ^b	68.9 (66.5, 71.3)	64.5 (62.1, 66.8)	4.5 (1.1, 7.8)	0.009
6MWT, mean, m ^a	262 (252, 272)	242 (232, 252)	20.1 (5.6, 34.7)	0.007
NT-proBNP, mean, pg ml ^{-1b}	733 (673, 799)	739 (678, 805)	0.99 (0.88, 1.12) ^c	0.900
BNP, mean, pg ml ^{-1b}	147 (136, 160)	147 (136, 160)	1.00 (0.89, 1.12) ^c	0.990
Systolic blood pressure, mean, mmHg ^b	133 (130, 135)	133 (131, 136)	-0.6 (-4.4, 3.3)	0.780
Weight, mean, kg ^b	101.3 (100.9, 101.8)	102.1 (101.6, 102.6)	-0.72 (-1.42, -0.01)	0.046

^aValues are shown as adjusted means (95% CI) for continuous variables. ^bAdjusted for the corresponding baseline value, history of T2DM, sex, AF, baseline eGFR and LVEF. ^cRatio of dapagliflozin compared with placebo.

Sources: Nassif *et al.* (2021).⁸¹

Abbreviations: AF: atrial fibrillation; 6MWT: 6-minute walk test; BNP: B-type natriuretic peptide; CI: confidence interval; CSS: Clinical Summary Score; eGFR: estimated glomerular filtration rate; KCCQ: Kansas City Cardiomyopathy Questionnaire; LVEF: left ventricular ejection fraction; N: number of patients in treatment group; NT-proBNP: N-terminal pro B-type natriuretic peptide; OSS: Overall Summary Score; T2DM: type 2 diabetes.

Figure 16: Effects of dapagliflozin on the primary endpoint and its components

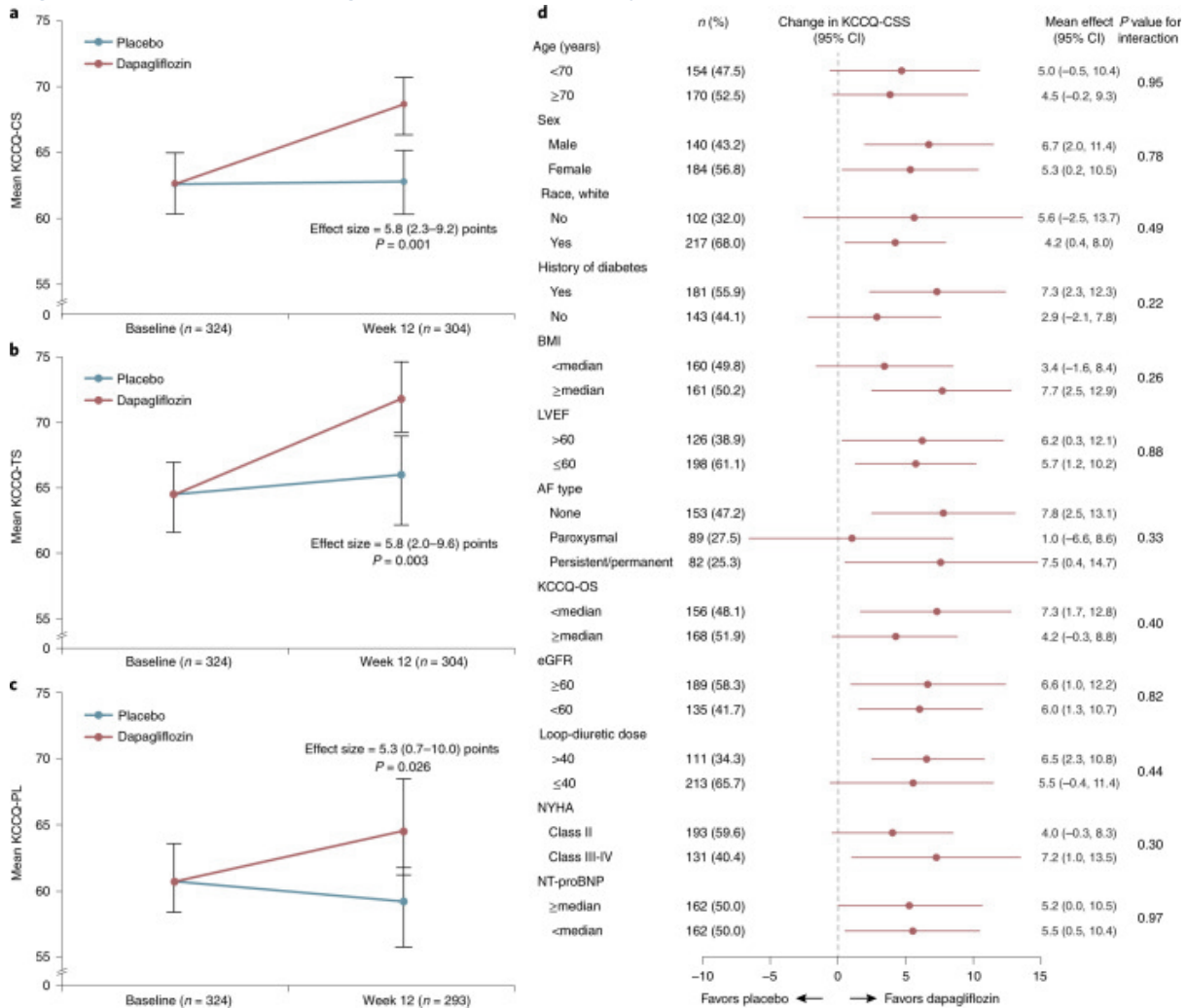

a-d Effects of dapagliflozin on the primary endpoint and its components. Effects of dapagliflozin versus placebo at 12 weeks on KCCQ-CS (a), KCCQ-TS (b), KCCQ-physical limitations score (KCCQ-PL) (c) and KCCQ-CS by subgroup (d). Units for loop diuretic dose (d), mg furosemide equivalents. Data are presented as mean values with 95% CI. a-c, An F-test was used in the data analysis. All P values are two-sided, with no adjustments made for multiple comparisons.

Sources: Nassif *et al.* (2021).⁸¹

Abbreviations: AF: atrial fibrillation; BMI: body mass index; eGFR: estimated glomerular filtration rate; KCCQ: Kansas City Cardiomyopathy Questionnaire; KCCQ-CS: KCCQ clinical score; KCCQ-OS: KCCQ overall score; KCCQ-TS: KCCQ total symptom; KCCQ-PL: KCCQ physical limitation; LVEF: left ventricular ejection fraction; NT-proBNP: N-terminal pro B-type natriuretic peptide; NYHA: New York Heart Association.

B.2.12. Adverse reactions

Summary of safety of dapagliflozin

- **The safety profile of dapagliflozin has been previously well reported** in other indications, including T2DM, CKD and HFrEF.⁸ In DELIVER and PRESERVED-HF, no new safety concerns with dapagliflozin were identified.^{76, 81}
- **In DELIVER, dapagliflozin was generally well tolerated in patients with HF and an LVEF >40%, consistent with the known safety profile.**⁷⁶ Likewise, in PRESERVED-HF, dapagliflozin was generally well tolerated in patients with HF and an LVEF ≥45%.⁸¹

- Overall, the safety profile in DELIVER was associated with:^{76, 78}
 - Balanced proportions of patients with SAEs (dapagliflozin 43.5% versus placebo 45.5%) and patients with an AE with outcome of death [REDACTED] between treatment groups.^{76, 78}
 - Low and balanced proportion of patients with AE leading to discontinuation of treatment (DAE) (dapagliflozin 5.8% versus placebo 5.8%) between treatment groups.⁷⁶
 - Balanced proportion of patients with AE leading to interruption of treatment (dapagliflozin 13.9% versus placebo 15.8%) between treatment groups as well.⁷⁶
 - [REDACTED] proportions of patients with SAEs suggestive of volume depletion [REDACTED] between treatment groups. DAEs suggestive of volume depletion ([REDACTED]) in the dapagliflozin group.^{76, 78}
 - Balanced SAEs of renal events [REDACTED] between treatment groups.^{76, 78}
 - Two patients with DKA events; [REDACTED] and were in the dapagliflozin group.^{76, 78}
 - Low and balanced proportions of patients with major hypoglycaemic events (dapagliflozin 0.2% versus placebo 0.2%) between treatment groups.⁷⁶
 - Balanced proportions of patients with amputations (dapagliflozin 0.6% versus placebo 0.8%) between treatment groups.⁷⁶
 - Balanced proportions of patients with cardiac ischaemic events [REDACTED] and strokes [REDACTED] between treatment groups.^{76, 78}
 - No cases of Fournier's gangrene.⁷⁶

Extensive safety data already exist for dapagliflozin in other indications, and the safety profile of dapagliflozin has been previously well reported.⁸ A summary of common and uncommon adverse drug reactions which have been experienced in these indications is therefore provided in B.2.12.3 based on the SmPC for dapagliflozin.⁸

B.2.12.1. Safety outcomes in DELIVER

In the DELIVER trial, safety and tolerability data were collected for all SAEs, AEs leading to discontinuation, amputation, AEs leading to amputation and potential risk factor AEs for amputations affecting lower limbs.⁷⁶

An overall summary of AEs for patients on treatment is presented in Table 22, while an overall summary for SAEs is shown in Table 23. The proportions of patients with SAEs and of patients with [REDACTED] were balanced between treatment groups.^{76, 78} The proportions of patients with DAEs were low and balanced between treatment groups.⁷⁶ The proportions of patients with AEs leading to interruptions of treatment were balanced between treatment groups.⁷⁶ The frequency of discontinuation of treatment was [REDACTED] between treatment groups (Figure 17).⁷⁸

The proportions of patients with SAEs suggestive of volume depletion were [REDACTED]

Company evidence submission template for dapagliflozin for treating chronic heart failure with preserved or mildly reduced ejection fraction [ID1648]

between treatment groups, whereas DAEs suggestive of volume depletion ██████████ ██████████ in the dapagliflozin group.⁷⁸ SAEs or DAEs of renal events were balanced between treatment groups.⁷⁶

There were 2 patients with adjudicated as definite DKA events in the dapagliflozin group compared with none in the placebo group; ██████████ patients had T2DM and were treated with insulin.^{76, 78} The proportions of patients with major hypoglycaemic events were low and balanced between treatment groups. The proportions of patients with amputations were balanced between treatment groups.⁷⁶

Table 22: Number of patients with AEs in any category in DELIVER – on treatment

	Number of patients (%) ^a	
	Dapagliflozin (N=3,126)	Placebo (N=3,127)
Any AE with outcome of death	████████	████████
Any SAE (including events with outcome of death)	1,361 (43.5)	1,423 (45.5)
Any AE leading to discontinuation of IP	182 (5.8)	181 (5.8)
Any AE leading to interruption of IP	436 (13.9)	494 (15.8)
Any AE possibly related to IP ^b	████████	████████
Any SAE or DAE suggestive of volume depletion ^c	42 (1.3)	32 (1.0)
Subjects with any DAE suggestive of volume depletion ^c	████████	████████
Any renal SAE or DAE ^c	73 (2.3)	79 (2.5)
AEs by system organ class and preferred term		
Any SAE suggestive of volume depletion ^c	████████	████████
Any renal SAE ^c	████████	████████
Any definite or probable diabetic ketoacidosis ^d	2 (0.1)	0
Any major hypoglycaemic event ^e	6 (0.2)	7 (0.2)
Any amputation ^f	19 (0.6)	25 (0.8)
Cardiac ischaemic AEs: any unstable angina or MI AE ^g	████████	████████
Unstable angina	████████	████████
Myocardial infarction ⁱ	████████	████████
Any stroke AE ^h	████████	████████
Any SAE of genital infection ^c	████████	████████
Any SAE of urinary tract infection ^c	████████	████████
Any SAE of tubulointerstitial nephritis	████████	█
Fournier' gangrene	0	0

^aSubjects with multiple events in the same category are counted only once in that category. Subjects with events in more than one category are counted once in each of those categories. ^bPossibly related to IP, as assessed by the Investigator. ^cBased on predefined list of preferred terms. ^dEvents adjudicated as definite or probable diabetic

ketoacidosis. ^eAE with the following criteria confirmed by the Investigator: i) symptoms of severe impairment in consciousness or behaviour ii) need of external assistance iii) intervention to treat hypoglycaemia iv) prompt recovery of acute symptoms following the intervention reported by the investigator in CRF. ^fReported by the investigator on the CRF amputation form, including surgical or spontaneous/non-surgical amputation, excluding amputation due to trauma. ^gInvestigator-reported diagnosis from the cerebrovascular events CRF (haemorrhagic, ischaemic, undetermined). ^hInvestigator-reported diagnosis from the cerebrovascular events CRF (haemorrhagic, ischaemic, undetermined). ⁱIncludes ST elevation myocardial infarction (STEMI), Non-ST elevation myocardial infarction (NSTEMI), and Myocardial infarction, ST elevation status unknown. This table includes AEs with an onset date on or after date of first dose of IP (on and off treatment), and on or after the first dose and up to and including 30 days following last dose of IP (on treatment). Percentages are based on the total numbers of patients in the treatment group (N).

Source: Solomon *et al.* (2022);⁷⁶ DELIVER CSR.⁷⁸

Abbreviations: AE: adverse event; CRF: case report form; DAE: AE leading to discontinuation of IP; Dapa: dapagliflozin; IP: investigational product; MI: myocardial infarction; N: number of patients in treatment group; SAE: serious AE.

Table 23: Number of patients with SAEs (≥ 0.5%) by preferred term in DELIVER – On treatment

	Number of patients (%) ^a	
	Dapagliflozin (N=3,126)	Placebo (N=3,127)
Subjects with any SAE	1,361 (43.5)	1,423 (45.5)
Cardiac failure	262 (8.4)	343 (11.0)
COVID-19	165 (5.3)	131 (4.2)
Pneumonia	97 (3.1)	96 (3.1)
COVID-19 pneumonia	78 (2.5)	81 (2.6)
Ischaemic stroke	66 (2.1)	60 (1.9)
Atrial fibrillation	57 (1.8)	47 (1.5)
Acute MI	51 (1.6)	58 (1.9)
Cardiac failure congestive	51 (1.6)	73 (2.3)
Cardiac failure acute	47 (1.5)	55 (1.8)
Acute kidney injury	46 (1.5)	50 (1.6)
Angina unstable	43 (1.4)	59 (1.9)
Death	36 (1.2)	38 (1.2)
Cellulitis	31 (1.0)	18 (0.6)
Urinary tract infection	30 (1.0)	32 (1.0)
Sudden cardiac death	23 (0.7)	30 (1.0)
Cardiac failure chronic	22 (0.7)	24 (0.8)
Peripheral arterial occlusive disease	22 (0.7)	14 (0.4)
Asymptomatic COVID-19	21 (0.7)	19 (0.6)
Sudden death	20 (0.6)	18 (0.6)
Angina pectoris	17 (0.5)	19 (0.6)
Chronic obstructive pulmonary disease	17 (0.5)	16 (0.5)

^a Number (%) of patients with SAEs, sorted by descending frequency of PT in Dapa 10 mg group. Subjects with multiple events in the same PT are counted only once in that PT. Subjects with events in more than

one PT are counted once in each of those PTs. This table includes SAEs with an onset date on or after date of first dose of IP, and up to and including 30 days following last dose of IP, with a frequency $\geq 0.5\%$ in the dapagliflozin treatment group.

Source: Solomon *et al.* (2022).⁸⁵

Abbreviations: COVID-19: coronavirus disease 2019; Dapa: dapagliflozin; IP: investigational product; MI: myocardial infarction; N: number of patients in treatment group; PT: preferred term; SAE: serious adverse event.

Figure 17: KM plot of the cumulative percentage of patients with premature permanent discontinuation of treatment in DELIVER^a

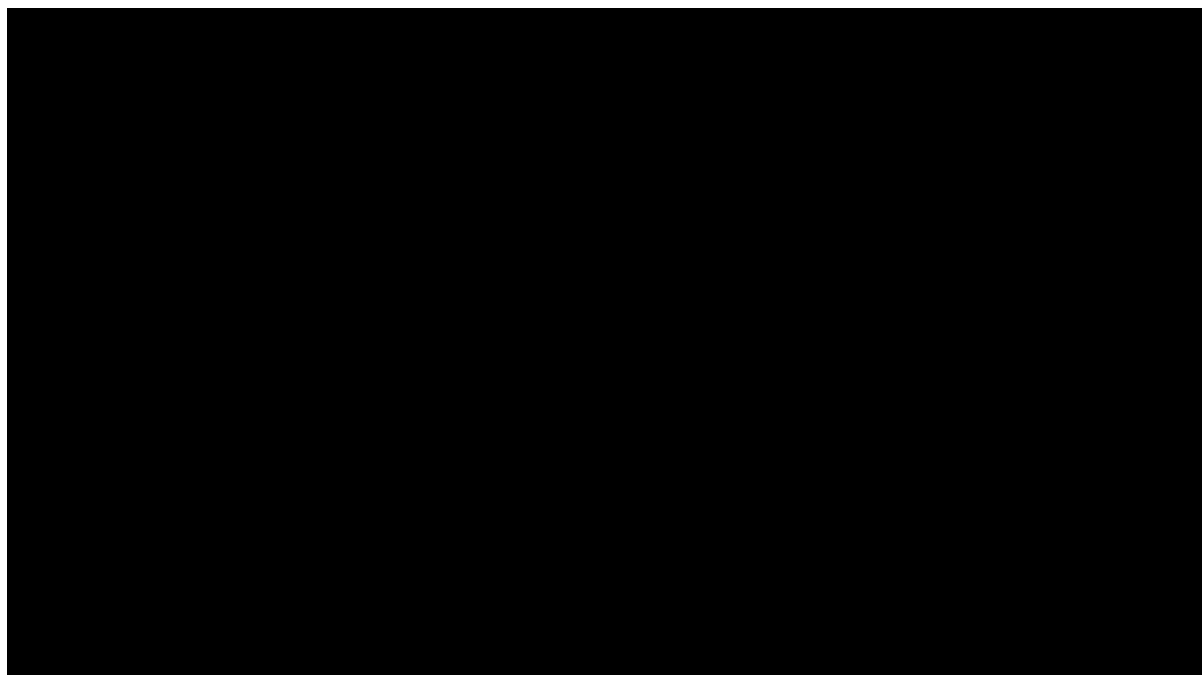

^aN at risk is the number of patients at risk at the beginning of the period. One month corresponds to 30 days. Two-sided p-value is displayed.

Source: DELIVER CSR.⁷⁸

Abbreviations: Dapa: dapagliflozin; D: dapa 10 mg; IP: investigational product; KM: Kaplan-Meier; N: number of patients; P: placebo.

B.2.12.2. Safety outcomes in PRESERVED-HF

Adverse events from the PRESERVED-HF trial are presented in Table 24. Overall, adverse events were similar between the dapagliflozin and placebo groups with 44 (27.2%) patients versus 38 (23.5%) patients experiencing adverse events, respectively.⁸¹

Table 24: Safety analysis in PRESERVED-HF

	Dapagliflozin (N=162)	Placebo (N=162)
All reported adverse events	44 (27.2%)	38 (23.5%)
Serious adverse events	31 (19.1%)	22 (13.6%)
Adverse events resulting in discontinuation of study medication	18 (11.1%)	15 (9.3%)
Drug adverse events	7 (4.3%)	8 (4.9%)
All-cause death	1 (0.6%)	2 (1.2%)
Nonfatal MI	0 (0%)	1 (0.6%)
Stroke	0 (0%)	1 (0.6%)
Acute kidney injury	5 (3.1%)	5 (3.1%)

Company evidence submission template for dapagliflozin for treating chronic heart failure with preserved or mildly reduced ejection fraction [ID1648]

© AstraZeneca (2022). All rights reserved

	Dapagliflozin (N=162)	Placebo (N=162)
DKA	0 (0%)	0 (0%)
Volume depletion events	11 (6.8%)	7 (4.3%)
Severe hypoglycaemic events	0 (0%)	0 (0%)
Lower limb amputations	0 (0%)	0 (0%)

Values are shown as absolute numbers (percentages) for patients with events.

Sources: Nassif *et al.* (2021).⁸¹

Abbreviations: DKA: diabetic ketoacidosis; MI: myocardial infarction; N: number of patients in treatment group.

B.2.12.3. Adverse drug reactions reported in the Summary of Product

Characteristics

A summary of common and uncommon adverse drug reactions which have been identified in the placebo-controlled clinical studies and post-marketing surveillance of dapagliflozin is provided in Table 25, based on the SmPC for dapagliflozin.

Table 25: Adverse drug reactions reported in the SmPC for dapagliflozin: adverse reactions in placebo-controlled clinical studies^a and postmarketing experience

System organ class	Very common	Common ^l	Uncommon ^m	Rare	Very rare
Infections and infestations	-	Vulvovaginitis, balanitis and related genital infections ^{*,b,c} Urinary tract infection ^{*,b,d}	Fungal infection ^m	-	Necrotising fasciitis of the perineum (Fournier's gangrene) ^{b,i}
Metabolism and nutrition disorders	Hypoglycaemia (when used with SU or insulin) ^b	-	Volume depletion ^{b,e} Thirst ^m	Diabetic ketoacidosis (when used in T2DM) ^{b,i,k}	-
Nervous system disorders	-	Dizziness	-	-	-
Gastrointestinal disorders	-	-	Constipation ^m Dry mouth ^m	-	-
Skin and subcutaneous tissue disorders	-	Rash ^l	-	-	Angioedema
Musculoskeletal and connective tissue disorders	-	Back pain ^l	-	-	-
Renal and urinary disorders	-	Dysuria Polyuria ^{f, l}	Nocturia ^m	-	-
Reproductive system and breast disorders	-	-	Vulvovaginal pruritus ^m Pruritus genital ^m	-	-
Investigations	-	Haematocrit increased ^g Creatinine renal clearance decreased during initial treatment ^b Dyslipidaemia ^h	Blood creatinine increased during initial treatment ^{b, m} Blood urea increased ^m Weight decreased ^m	-	-

^aThe table shows up to 24-week (short-term) data regardless of glycaemic rescue. ^bSee corresponding subsection of SmPC for additional information. ^cVulvovaginitis, balanitis and related genital infections includes, e.g., the predefined preferred terms: vulvovaginal mycotic infection, vaginal infection, balanitis, genital infection fungal, vulvovaginal candidiasis, vulvovaginitis, balanitis candida, genital candidiasis, genital infection, genital infection male, penile infection, vulvitis, vaginitis bacterial, vulval abscess. ^dUrinary tract infection includes the following preferred terms, listed in order of frequency reported: urinary tract infection, cystitis, Escherichia urinary tract infection, genitourinary tract infection, pyelonephritis, trigonitis, urethritis, kidney infection and prostatitis. ^eVolume depletion includes, e.g., the predefined preferred terms: dehydration, hypovolaemia, hypotension. ^fPolyuria includes the preferred terms: pollakiuria, polyuria, urine output increased. ^gMean changes from baseline in haematocrit were 2.30% for dapagliflozin 10 mg versus -0.33% for placebo. Haematocrit values >55% were reported in 1.3% of the patients treated with dapagliflozin 10 mg versus 0.4% of placebo patients. ^hMean percent change from baseline for dapagliflozin 10 mg versus placebo, respectively, was: total cholesterol 2.5% versus 0.0%; HDL cholesterol 6.0% versus 2.7%; LDL cholesterol 2.9% versus -1.0%; triglycerides -2.7% versus -0.7%. ⁱSee section 4.4 of the SmPC. ^lAdverse reaction was identified through postmarketing surveillance. Rash includes the following preferred terms, listed in order of frequency in clinical studies: rash, rash generalised, rash pruritic, rash macular, rash maculo-papular, rash pustular, rash vesicular, and rash erythematous. In active- and placebo-controlled clinical studies (dapagliflozin, N=5936, All control, N=3403), the frequency of rash was similar

for dapagliflozin (1.4 %) and all control (1.4%), respectively. ^kReported in the CV outcomes study in patients with type 2 diabetes (DECLARE). Frequency is based on annual rate. ^lReported in $\geq 2\%$ of patients and $\geq 1\%$ more and at least 3 more patients treated with dapagliflozin 10 mg compared with placebo.

^mReported by the investigator as possibly related, probably related or related to study treatment and reported in $\geq 0.2\%$ of patients and $\geq 0.1\%$ more and at least 3 more patients treated with dapagliflozin 10 mg compared with placebo.

Source: Forxiga 10 mg film-coated tablets [SmPC].⁸

Abbreviations: HDL: high density lipoprotein; LDL: low density lipoprotein; T2DM: type 2 diabetes mellitus.

B.2.13. Ongoing studies

There are no ongoing trials relevant to this appraisal.

B.2.14. Interpretation of clinical effectiveness and safety evidence

B.2.14.1. Principal outcomes from DELIVER and PRESERVED-HF highlighting the clinical benefits and harms of the technology

DELIVER is one of the first trials including patients with HF and an LVEF >40% that has demonstrated statistically significantly improved outcomes in this highly underserved patient population

To date, all but a few recently published RCTs have failed to demonstrate significant clinical benefits for treatments in patients with HF and an LVEF >40%.^{58, 76, 95} As such, there are no targeted, disease-modifying treatments indicated or commissioned by the NHS to treat this patient population. Without an efficacious, well-tolerated treatment, patients with HF and an LVEF >40% experience poor clinical outcomes and HRQoL and face a life expectancy worse than patients with some cancers.³² As such, clinical care is currently limited to symptomatic treatment and/or treatment for underlying co-morbidities, rather than treatments for HF and an LVEF >40%. There is therefore an urgent need for easily accessible new treatments which can reduce mortality and hospitalisation and improve disease symptoms and quality of life.

DELIVER (N=6,263) is one of a few RCTs to demonstrate statistically significantly improved outcomes in patients with HF and an LVEF >40%.^{76, 81, 95} DELIVER was also the first trial to include patients with HFimpEF and to demonstrate a [REDACTED] in this patient subgroup. The treatment benefits of dapagliflozin versus placebo, when given in addition to SoC, in DELIVER demonstrate that dapagliflozin is a key opportunity to significantly reduce worsening of HF in patients with HF and an LVEF >40%.⁷⁶

Consistent with other phase III RCTs of dapagliflozin, a statistically significant reduction in the risk of the primary composite endpoint of CV mortality and HF events was observed for dapagliflozin compared with placebo in DELIVER⁷⁶

Dapagliflozin significantly reduced the incidence of the primary composite endpoint of CV mortality and HF events by 18% compared with placebo in the DELIVER trial (HR 0.82; 95% CI 0.73, 0.92; $p < 0.001$).⁷⁶ The treatment benefit on the primary composite endpoint was consistent across the key prespecified subgroups.⁷⁶

This significant reduction in the primary composite endpoint of CV mortality and HF events is consistent with outcomes from other dapagliflozin RCTs.⁹⁶ In the DAPA-HF trial, which enrolled patients aged ≥ 18 years with NYHA functional class $\geq II$ and an LVEF $\leq 40\%$ who were currently optimally treated for HFrEF, dapagliflozin reduced the relative risk of CV mortality or an HF event

Company evidence submission template for dapagliflozin for treating chronic heart failure with preserved or mildly reduced ejection fraction [ID1648]

© AstraZeneca (2022). All rights reserved

Page 75 of 134

by 26% (HR 0.74; 95% CI: 0.65, 0.85; $p < 0.001$).⁹⁷ In the DAPA-CKD trial, which enrolled patients with CKD (eGFR ≥ 25 and ≤ 75 ml/min/1.73 m², and uACR ≥ 200 mg/g to $\leq 5,000$ mg/g [≥ 22.6 to ≤ 565 mg/mmol]), dapagliflozin was associated with a 29% reduction in the relative risk of HHF or CV mortality (HR 0.71; 95% CI: 0.55, 0.92; $p = 0.009$).⁹⁸

In the DELIVER trial, dapagliflozin also statistically significantly reduced the relative risk of the secondary composite endpoint of CV mortality and recurrent HF events by 23% compared with placebo⁷⁶

In the DELIVER trial, dapagliflozin was statistically significantly superior to placebo in reducing the incidence of the of total (first and recurrent/ repeat) HF events and CV mortality (RR 0.77; 95% CI: 0.67, 0.89; $p < 0.001$).⁷⁶ Dapagliflozin was also statistically significantly superior to placebo in reducing the incidence of recurrent HF events (RR 0.73; 95% CI: 0.62, 0.87; $p = 0.0003$). Dapagliflozin reduced the incidence of CV mortality and all-cause mortality although the differences were not statistically significant (HR 0.88; 95% CI: 0.74, 1.05; $p = 0.1678$ and HR 0.94; 95% CI: 0.83, 1.07; $p = 0.3425$, respectively).^{76, 78} Consistent with results from the DELIVER trial, as demonstrated by the pooled analysis for the DELIVER and DAPA-HF trials, dapagliflozin in HF irrespective of LVEF significantly reduced total hospital admissions for HF by 29% (RR 0.71; 95% CI: 0.65, 0.78; $p < 0.001$).⁹⁴ These clinical benefits further demonstrate the value that dapagliflozin could offer patients and the NHS by improving outcomes and reducing the resource utilisation associated with HF and an LVEF $> 40\%$.

The treatment effect of dapagliflozin was highly consistent across prespecified subgroups including those defined by LVEF, with no attenuation of treatment effect in the highest LVEF group ($> 60\%$) or those with HFimpEF^{76, 79}

The results observed in the DELIVER FAS were consistently reflected in key prespecified subgroups.⁷⁶ Importantly, when the population was stratified into LVEF $\leq 49\%$, $50\% - 59\%$, and $\geq 60\%$, the treatment effect with dapagliflozin remained consistent across the groups (p -value for interaction = \blacksquare),⁷⁸ suggesting no attenuation of treatment effect in patients with a higher LVEF.⁷⁶ This is a critical finding given that previous trials of treatments for patients with HF and an LVEF $> 40\%$ appeared to show a trend towards an attenuation of treatment effect in those with a higher LVEF.⁹⁵

Similarly, results were also consistent between patients with HFimpEF and those with HF and an LVEF consistently $> 40\%$ (p -value for interaction = \blacksquare).^{76, 79} This is an important finding since patients with HFimpEF were previously unstudied. Taken together, and considered alongside the results from DAPA-HF, these results demonstrate that initiating dapagliflozin in patients with HF is associated with a consistent treatment effect irrespective of LVEF.

In a pooled analysis of the DELIVER and DAPA-HF trials, dapagliflozin was associated with a statistically significant reduction in the risk of CV mortality and mortality from any cause of 14% and 10%, respectively, in patients with HF irrespective of LVEF⁹⁴

In the pooled analysis of the DELIVER and DAPA-HF trials, dapagliflozin significantly reduced the risk of mortality from CV causes in HF irrespective of LVEF by 14% (HR 0.86; 95% CI: 0.76, 0.97; $p = 0.01$), and the risk of mortality from any cause by 10% (HR 0.90; 95% CI: 0.82, 0.99; $p = 0.03$).⁹⁴ These results are broadly consistent with reductions in both CV mortality and all-cause mortality reported in the DELIVER and DAPA-HF trials,^{76, 97} with the higher power of the pooled analysis resulting in statistically significant differences being demonstrated.⁹⁴ Dapagliflozin offers a key opportunity to reduce mortality across the spectrum of HF regardless of LVEF, which is of critical importance given the high mortality rates associated with HF,¹⁴ and the NHS Long Term

Plan having identified CVD as the single biggest area where lives can be saved by 2029 in England.⁴⁶

Treatment with dapagliflozin provides meaningful symptom relief in patients with HF and an LVEF >40% based on both the DELIVER and the PRESERVED-HF trials^{76, 81, 93}

Given the high morbidity burden associated with HF and an LVEF >40%,³² improving disease symptoms in addition to treatment outcomes is a primary goal in the management of these patients. In the DELIVER trial, dapagliflozin provided symptom benefits over placebo as measured by KCCQ-TSS (mean difference in change from baseline 2.4 [95% CI: 1.5, 3.3] points higher versus placebo; $p < 0.001$).^{76, 79, 93} Similarly, in the PRESERVED-HF trial, 12-week treatment with dapagliflozin versus placebo was associated with statistically significant improvements in patient-reported symptoms, physical limitation and exercise function.⁸¹

Dapagliflozin was generally well tolerated, consistent with its known safety profile

In DELIVER, dapagliflozin showed a favourable tolerability profile compared with placebo; SAEs were numerically less frequent with dapagliflozin (43.5%) than with placebo (45.5%) and there was no difference in incidence of AEs leading to discontinuation between dapagliflozin (5.8%) and placebo (5.8%).⁷⁶ In DELIVER and PRESERVED-HF, no new safety concerns were identified.^{76, 81} Dapagliflozin is already routinely commissioned to treat T2DM,⁵⁻⁷ CKD,⁹ and HFrEF,¹ thus clinicians across both primary and secondary care settings have considerable clinical experience in the prescribing of dapagliflozin. Therefore, the lack of new safety concerns from DELIVER and PRESERVED-HF provides reassurance about the known safety profile clinicians are already familiar with.

Dapagliflozin is a vital new treatment option for patients with HF and an LVEF >40%, with the potential to significantly reduce the burden of HF on patients and the healthcare system

The DELIVER results demonstrate that dapagliflozin is an effective and well tolerated treatment which can help ease the substantial burden of HF and an LVEF >40% to patients and the NHS.⁷⁶ Benefits associated with dapagliflozin in this patient population include improved outcomes, including mortality and patient-reported symptoms, and lowered healthcare resource use in HF, such as HF events, compared with placebo.^{76, 81, 94}

Improved outcomes with dapagliflozin compared with SoC are key to tackling the current burden associated with HF and an LVEF >40%, including the high mortality,^{14, 32} and poor HRQoL.³² Improving care in HF will support achieving one of the priorities of the NHS Long Term Plan, in which CVD has been identified as the single biggest area where lives can be saved by 2029 in England.⁴⁶ Given that HF and an LVEF >40% is associated with a substantial economic burden, primarily driven by high rates of HHF,³⁸⁻⁴² dapagliflozin offers a key opportunity to reduce healthcare resource use in HF, including HF events, for the NHS. Although the availability of novel therapies for patients with HF and an LVEF >40% may result in a greater focus on specialist service provision, service redesign specifically for dapagliflozin would not be necessary as it does not require up-titration nor specific additional monitoring.

Given that there is substantial clinical experience in the prescribing of SGLT2 inhibitors in primary care, AstraZeneca believes that there is no clinical rationale for restricting the initiation of dapagliflozin for patients with HF and an LVEF >40% to advice from a HF specialist only. In this context, a specialist confirmed HF diagnosis is likely to remove uncertainty such as misdiagnosis

and associated over-treatment, and to increase confidence in primary care physicians to initiate treatment that they are familiar with in newly diagnosed patients and those recently discharged from HF specialist services.

For the prevalent population of patients with a diagnosis of HF and an LVEF >40% already managed in primary care or for those who are not routinely followed-up within specialist care, initiation of dapagliflozin could take place at the earliest opportunity, ideally following proactive invitation for a treatment optimisation review or alternatively, where capacity is a limitation, during their routine check-up appointment without the need for a specific or extended appointment. Initiating treatment for patients within primary care will support the NHS with its COVID-19 recovery plans, reducing wait times to outpatient services,⁹⁹ and will reduce unwarranted variations in care across England and Wales. Thus, enabling initiation of dapagliflozin in both primary and secondary care for the treatment of this patient population would ensure consistent equality of access without relying on specialist care, which may not exist in some areas for these patients.

B.2.14.2. Strengths and limitations of the clinical evidence base for the technology

DELIVER was a large (N=6,263), Phase III, international, multi-centre, double-blind, placebo-controlled high quality RCT, which enrolled a patient population with a broad range of co-morbidities, including patients with and without T2DM.⁷⁶ DELIVER was designed with broader inclusion criteria than those used in previous trials involving similar populations; it enrolled patients who were hospitalised or recently hospitalised, for whom evidence-based therapy is limited, as well as those with HF and an LVEF previously $\leq 40\%$ prior to enrolment.⁷⁶ Data from DELIVER suggest that these understudied groups also benefit from dapagliflozin.⁷⁶

Overall, demographic and other baseline patient characteristics were well balanced between treatment groups.⁷⁶ The outcome measures selected were those most relevant to patients with HF and an LVEF >40%, including CV mortality and HF events, with a composite of these outcomes as the primary efficacy measure.⁷⁶

Moreover, the overall impact of the COVID-19 pandemic on the efficacy evaluation was assessed as low and the COVID-19 pandemic was judged not to have had a meaningful impact on the interpretation of results of the trial.⁷⁶

Based on UK clinical expert feedback, the DELIVER trial is overall considered to be reflective of SoC used in UK clinical practice.¹⁰ Although the trial did not enrol any UK patients, it included a large European and American cohort, where treatments are expected to be similar to those in UK clinical practice.⁷⁶ Discrepancies mentioned by UK clinical experts included the trial mean age of 71.7 years,⁸⁰ which appears slightly younger than in UK clinical practice as demonstrated by the average of ■■■ years in the CPRD analysis (see Section B.3.3.2),^{10, 62} the likelihood of an increased proportion of patients with NYHA class II HF in UK clinical practice than in the trial, and the potential to have higher proportion of patients from African and Caribbean background in some areas than in the trial.^{10, 62, 76} While there are some differences between DELIVER and UK clinical practice, UK clinical experts generally agreed that the trial is broadly representative of UK clinical practice.¹⁰ Nonetheless, AstraZeneca recognises these differences and have, therefore, performed a scenario analysis using the CPRD dataset in addition to using the DELIVER trial cohort in the base case cost-effectiveness analysis (see Section B.3.10.3).

B.3. Cost effectiveness

Summary of cost effectiveness

- A cost-utility model was developed to estimate the cost-effectiveness of dapagliflozin in addition to SoC (defined as loop diuretics, either furosemide or bumetanide) versus placebo in addition to SoC (hereafter referred to as SoC alone for ease of reading) for the treatment of adult patients with HF and an LVEF >40%.
- The model was a Markov cohort model with health states based on KCCQ-TSS scores. Disease progression was modelled through transitions between discrete health states characterised by KCCQ-TSS quartiles (scores of 0–<55, 55–<73, 73–<88, 88–100, where higher scores represent better health status), with health state-specific clinical event rates, costs and utility values.
- Baseline characteristics and clinical evidence for the efficacy of dapagliflozin in addition to SoC and SoC alone were derived directly from the DELIVER trial, and applied in the economic model as transition probabilities, survival equations and risk equations. These were used to model clinical events, including HF events, CV mortality and all-cause mortality, as well as any relevant AEs.
- Health state utility values and clinical event disutility values were derived from the DELIVER trial and AE utility decrements were sourced from the published literature.
- The analysis was consistent with the NICE reference case and took an NHS and PSS perspective. Costs and benefits were discounted at a rate of 3.5% and a lifetime time horizon was adopted.
- In the deterministic base case economic analysis, treatment with dapagliflozin in addition to SoC, compared with SoC alone, was associated with increased life years (+0.369 per patient) and increased QALYs (+0.250 per patient), at an incremental cost of +£1,880 per patient. As a result, dapagliflozin in addition to SoC was highly cost-effective compared with SoC alone, with an ICER of £7,507/QALY gained.
- The probabilistic base case economic analysis results were similar to the deterministic base case results, demonstrating that the cost-effectiveness of dapagliflozin is robust to uncertainties associated with the model input parameters. The probabilistic sensitivity analysis (PSA) showed that the probabilities of cost-effectiveness for dapagliflozin at willingness-to-pay (WTP) thresholds of £20,000/QALY and £30,000/QALY gained were 89.0% and 92.3%, respectively.
- The most influential factors of the deterministic sensitivity analysis (DSA) were the annual probability of amputation for dapagliflozin in addition to SoC and SoC alone and the event cost of HHF. Overall,, dapagliflozin in addition to SoC remained highly cost-effective compared with SoC alone with ICERs below £9,000/QALY gained for all upper and lower input values varied in the DSA.
- Similarly, all scenario analyses demonstrated the base case economic analysis to be robust, with probabilistic ICERs remaining below £12,500/QALY gained in all scenarios.
- In conclusion, the economic analysis shows dapagliflozin to represent a highly cost-effective use of NHS resources, as an add-on therapy to SoC for the treatment of adults with HF and an LVEF >40%.

B.3.1. Published cost-effectiveness studies

An economic SLR was conducted in June 2022 to identify any relevant published cost-effectiveness analyses, utilities studies, or cost and resource use studies in patients with HF and an LVEF >40%. Full details of the methodology and results of the economic SLR are presented in Appendix G, H and I.

In total, only one economic evaluation was identified in the cost-effectiveness analyses SLR: a cost per outcome study (Tsaban *et al.* [2021]),¹⁰⁰ which evaluated the annual number needed to treat to prevent the composite outcome of HF hospitalisation and CV mortality for either spironolactone or sacubitril/valsartan.

The study is summarised in Appendix G, but was not considered to provide relevant evidence to the decision problem of this submission, or any relevant assumptions that could be leveraged for the economic analysis of this submission, and was therefore not considered further.

B.3.2. Economic analysis

In the absence of identifying any previously conducted cost-effectiveness studies relevant to the decision problem of this submission in the economic SLR, a *de novo* economic model was developed for this submission, based on the modelling approach adopted in previous economic models in HFrEF (TA388 and TA679) which have been accepted by NICE.^{1, 101}

In particular, the model structure used in this appraisal is closely aligned with the model used in the previous appraisal for dapagliflozin as a treatment for HFrEF (TA679), as discussed with the EAG and NICE prior to this submission.¹

A summary of the key differences between the underlying model structure and methodology in TA679 versus the economic model developed for this submission is provided in Table 26. It should be noted that in addition to these differences, the model inputs used in TA679 were reviewed and updated to include inputs from the DELIVER trial, or those from the published literature considered most appropriate to this appraisal, as detailed in the sections below.

Table 26: Summary of the key differences in modelling approaches between TA679 versus this appraisal

Change		Rationale
TA679	This appraisal	
Baseline stratification of patients by T2DM status.	No baseline stratification of patients by T2DM status.	While patients were stratified by T2DM in TA679, dapagliflozin has now been approved in other indications, outside of T2DM; as such, it was no longer considered appropriate to stratify patients by T2DM in this appraisal. Furthermore, no difference in treatment effect depending on T2DM status was observed in the DELIVER trial, in line with previous dapagliflozin trials, including DAPA-HF and DAPA-CKD. ^{1, 9, 76} It should be noted that T2DM status is included as a covariate in both the adjusted models for CV and all-cause mortality (Section B.3.3.5), and HF event incidence (Section B.3.3.7), so any interaction of

Change		Rationale
TA679	This appraisal	
		T2DM on clinical outcomes is accounted for in the model.
Standard parametric models, which did not account for changes in hazards over time, were used for modelling of CV and all-cause mortality.	Piecewise parametric models were used for CV- and all-cause mortality, to reflect the changes in the hazard of death over time.	Evaluation of the hazard functions associated with CV- and all-cause mortality in the DELIVER trial indicated that a clear inflection point in the hazards was observed after Year 1, meaning that the use of piecewise models fitted separately to Year 1 and Year 2+ were considered to represent the most appropriate approach; as detailed in Section B.3.3.5.
Unadjusted risk equation for UHFV.	Adjusted risk equation for UHFV.	In the DAPA-HF trial (used in TA679 ¹), only 39 UHFV events were observed, and therefore the use of an adjusted equation for UHFV was not considered feasible. In comparison, ■ UHFV events were observed in DELIVER; the increased number of events means that an adjusted UHFV model was feasible, and as such, was incorporated into the base case economic analysis (Section B.3.3.7). ⁷⁸
Health state utilities and utility decrements were derived using van Hout <i>et al.</i> (2012) ¹⁰² methodology.	Health state utilities and utility decrements were derived using Hernandez-Alava <i>et al.</i> (2017), based on the Hernandez Alava <i>et al.</i> (2020) dataset. ^{103, 104}	In line with the revised NICE methods guide published in 2022. ¹⁰⁵

Abbreviations: CV: cardiovascular; NICE: National Institute for Health and Care Excellence; T2DM: type 2 diabetes mellitus; TA: technology appraisal; UHFV: urgent heart failure visit.

B.3.2.1. Patient population

In line with the expected licensed indication and the decision problem for the current submission, the base case economic analysis evaluated adult patients with HF and an LVEF >40%. This is aligned to the population investigated in the DELIVER trial which is the pivotal study for dapagliflozin in addition to SoC versus placebo in addition to SoC (SoC alone) in this indication (see Section B.2.2).

B.3.2.2. Model structure

A Markov state-transition model was developed whereby disease progression was modelled through transitions between discrete health states characterised by KCCQ-TSS quartiles with the following scores, with higher scores representing better health status:

- Q1: 0–<55
- Q2: 55–<73
- Q3: 73–<88
- Q4: 88–100

As discussed in Section B.1.3.4, the KCCQ-TSS is an extensively validated and established self-

Company evidence submission template for dapagliflozin for treating chronic heart failure with preserved or mildly reduced ejection fraction [ID1648]

administered instrument for quantifying HF-related symptoms, function, and HRQoL in patients with HF.⁶⁷ As a specifically designed patient-reported measure of HF health status, reflective of patient utility, KCCQ-TSS quartiles were considered appropriate for defining health states in the economic model. The inclusion of KCCQ-TSS quartiles for health states also has a precedent in economic modelling in HF, in line with the previous model structure accepted for the NICE appraisal for dapagliflozin for HFrEF in TA679.¹

A schematic overview of the economic model structure is presented in Figure 18. Each health state was assigned health state-specific utility values. This represents one of the advantages of this model structure, as the KCCQ-TSS health states enable the impact of disease severity to be captured in the health state utility values and in the risk of events, and therefore allow the impact of disease severity to be more accurately modelled.

Additionally, the model captured the incidence of HF events as transient events. Patient mortality (i.e., transition to the absorbing dead state) was modelled through the application of parametric survival equations describing CV mortality and all-cause mortality.

At each cycle, the proportion of patients who died from CV causes was estimated and the costs associated with CV mortality were applied. The non-CV mortality rate was estimated as the difference between the all-cause mortality rate and the CV mortality rate, which was also applied to all KCCQ-TSS health states. The transition probability matrix for the different KCCQ-TSS quartiles was then applied to the remaining number of patients alive, to calculate the health state distribution in the next cycle (see Section B.3.3.3).

Patients had a per-cycle probability of discontinuing treatment with dapagliflozin due to intolerability or other reasons, based on the DELIVER trial, as detailed in Section B.3.3.4 below.⁷⁸ Patients discontinuing treatment with dapagliflozin in addition to SoC were then modelled to experience the same event rates as patients receiving SoC alone.

Figure 18: Schematic of Markov state-transition model structure, health states, and possible transitions

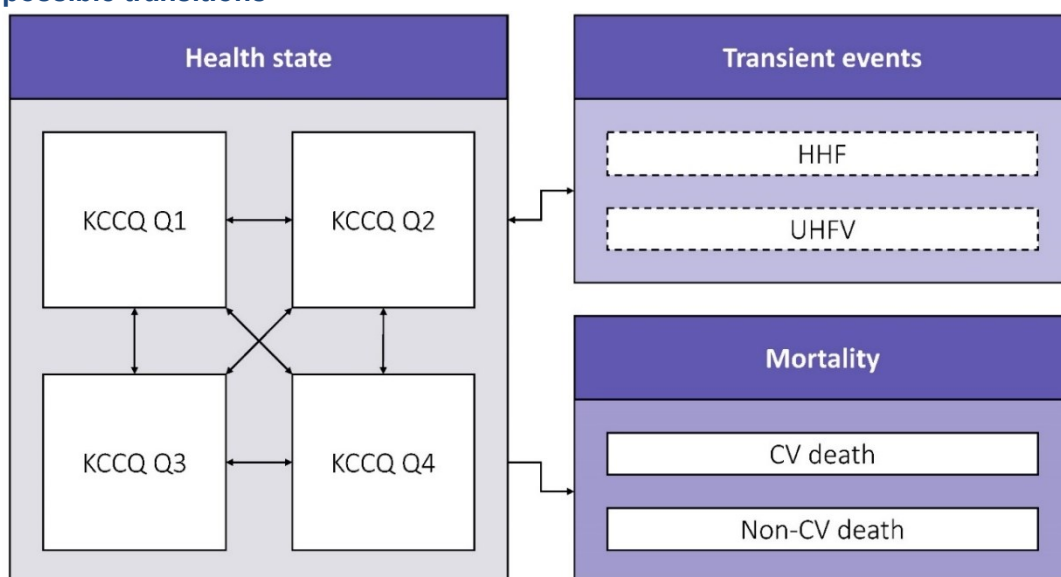

Abbreviations: CV: cardiovascular; HHF: hospitalisation for heart failure; KCCQ: Kansas City Cardiomyopathy Questionnaire; UHFV: urgent heart failure visit.

Justification of model structure

The implementation of a Markov state-transition model was considered appropriate as the heterogeneity between patients with HF and an LVEF >40% with respect to important disease characteristics can be captured by a tractable number of mutually exclusive and exhaustive health states. The use of a Markov model structure is aligned with the model structure used in the previous NICE appraisal for dapagliflozin in patients with HFrEF (TA679), and prior discussion with the NICE and EAG indicated that a similar model structure would be suitable for this appraisal.¹

HF is a chronic and progressive disease associated with an increased risk of mortality over time. As such, the model incorporated a lifetime horizon in line with the NICE Methods Guide.¹⁰⁵ Consistent with UK 2017–2019 life tables, it was assumed that all patients died upon reaching 101 years old.¹⁰⁶

The cycle length was one month, and a half-cycle correction was applied, in line with TA679.¹

A summary of the key model characteristics is presented in Table 27.

Table 27: Key features of the economic analysis

Factor	Current evaluation	
	Chosen values	Justification
Model structure	Cohort Markov model, with health states by KCCQ-TSS quartiles.	<p>The KCCQ-TSS health states enable disease severity to be a covariate in the survival/risk/utility equations, allowing the impact of disease severity to be accurately modelled.</p> <p>Cohort Markov models sufficiently capture the heterogeneity between patients with HF and an LVEF >40% and additionally have the advantage of having quicker runtimes in comparison to individual patient level models (as discussed in TA388).¹⁰¹</p> <p>In the previous NICE appraisal for dapagliflozin in patients with HFrEF (TA679), the NICE Committee concluded that the KCCQ tool is a reasonable way to classify disease severity, and was considered appropriate for decision making.¹ It was agreed through prior discussion with the NICE and EAG that the use of the same model structure would be appropriate for this appraisal.</p>
Time horizon	Lifetime.	HF is a chronic disease, for which treatments have an impact on costs and outcomes over a patient's lifetime.
Treatment waning effect?	Not applied.	No treatment waning effect of dapagliflozin was identified in the DELIVER trial, and no treatment waning was modelled in previous appraisals of interventions for the treatment of HF. ^{1, 78}
Source of utilities	DELIVER trial.	As per the NICE Methods Guide. ¹⁰⁵
Source of costs	Costs related to NHS and PSS resources were valued using relevant sources, including the NHS Reference Costs	As per the NICE Methods Guide. ¹⁰⁵

	(2020/2021) ¹⁰⁷ , PSSRU ¹⁰⁸ , BNF ¹² and eMIT; ¹⁰⁹ other cost inputs were informed by systematic and targeted literature reviews.	
Discounting	3.5% per annum for costs, QALYs and life years.	As per the NICE Methods Guide. ¹⁰⁵
Perspective of outcomes	All direct health effects.	As per the NICE Methods Guide. ¹⁰⁵
Perspective of costs	NHS and PSS .	As per the NICE Methods Guide. ¹⁰⁵

Abbreviations: KCCQ-TSS: Kansas City Cardiomyopathy Questionnaire Total Symptom Score; NHS: National Health Service; NICE: National Institute for Health and Care Excellence; PSS: Personal Social Services; QALY: quality-adjusted life year.

B.3.2.3. Intervention technology and comparators

The intervention technology is oral dapagliflozin (10 mg) once daily. In line with the proposed positioning of dapagliflozin in the treatment pathway for patients with HF and an LVEF >40%, dapagliflozin is to be given as an add-on therapy to current SoC. Therefore the intervention arm of the economic analysis comprised dapagliflozin in addition to SoC.

The principal comparator to dapagliflozin in addition to SoC in this submission is placebo in addition to SoC (hereafter, referred to as SoC alone).

Dapagliflozin plus SoC

Dapagliflozin was modelled in line with the SmPC at a dose of 10 mg orally once daily until treatment discontinuation,⁸ while SoC for patients receiving dapagliflozin was modelled in line with the modelling approach for SoC alone, detailed below.

A constant probability of dapagliflozin treatment discontinuation was included in the model, and once patients discontinued treatment with dapagliflozin they became subject to the same risks, costs and utility decrements as patients in the SoC arm of the model (see Section B.3.3.4).

SoC

The principal comparator to dapagliflozin in addition to SoC in this submission is SoC alone. There are currently no disease-modifying treatment options for patients with HF and an LVEF >40% and in UK clinical practice, SoC for this patient population consists of loop diuretics prescribed for symptom relief (see Section B.1.3.5).

SoC within the base case economic analysis was modelled as the cost of loop diuretics, assumed to be comprised of a weighted average of 80% furosemide (40 mg orally once daily) and 20% bumetanide (1 mg orally once daily), based on UK clinical expert feedback that these are the most commonly used loop diuretics in UK clinical practice.^{110, 111} The costs of SoC were applied to both arms of the model (see Section B.3.5.1). No discontinuation of SoC was assumed within the model.

The modelling of further additional therapies to treat comorbidities was not included, given the use of these therapies is expected to be the same for patients receiving dapagliflozin in addition to SoC and those receiving SoC alone. As such, any differences in the costs associated with further additional therapies to treat comorbidities was assumed to be negligible, and it was not

considered necessary to explicitly model these therapies.

B.3.3. Clinical parameters and variables

B.3.3.1. Incorporation of clinical data within the model

Data from the DELIVER trial were incorporated directly into the dapagliflozin economic model to inform: patient baseline characteristics, KCCQ-TSS quartile health state transition probabilities, survival curves for mortality, incidence of HF events, incidence of AEs and probability of treatment discontinuation. Additionally, health state utility values and utility decrements for HF events were also derived directly from the DELIVER trial (see Section B.3.4.1 and Section B.3.4.5, respectively).

The treatment effect of dapagliflozin was incorporated into the economic model as coefficients for the survival equations and risk equations for all-cause mortality, CV mortality and HF events. Additionally, [REDACTED] with respect to change in KCCQ-TSS from baseline in the DELIVER trial was incorporated in the economic model as treatment-specific KCCQ-TSS quartile transition probabilities.⁷⁸

B.3.3.2. Baseline characteristics

DELIVER ITT population

The patient baseline characteristics informing the economic model were derived from the DELIVER trial, and are summarised below in Table 28 (demographic characteristics), Table 29 (clinical characteristics) and Table 30 (medical history). The patient baseline characteristics determined the initial distribution of the modelled cohort across the alive health states and influenced the rates of all-cause mortality, CV mortality and HF events estimated by the covariate-adjusted survival equations and covariate-adjusted risk equations.

Table 28: Patient demographic characteristics incorporated in the base case economic analysis

Patient characteristic	Mean	SE
Mean age (years)	[REDACTED]	[REDACTED]
Proportion male	0.561	[REDACTED]
Mean BMI (kg/m ²)	[REDACTED]	[REDACTED]
Race		
Proportion white	[REDACTED]	[REDACTED]
Proportion Black/African	0.025	[REDACTED]
Proportion other	[REDACTED]	[REDACTED]

Abbreviations: BMI: body mass index; SE: standard error.

Source: Solomon *et al.* (2022);⁸⁰ DELIVER CSR.⁷⁸

Table 29: Patient clinical characteristics incorporated in the base case economic analysis

Patient characteristic	Mean	SE
KCCQ quartiles		
Proportion in KCCQ-TSS Q1	[REDACTED]	[REDACTED]
Proportion in KCCQ-TSS Q2	[REDACTED]	[REDACTED]

Company evidence submission template for dapagliflozin for treating chronic heart failure with preserved or mildly reduced ejection fraction [ID1648]

Proportion in KCCQ-TSS Q3	■	■
Proportion in KCCQ-TSS Q4	■	■
Other clinical characteristics		
Mean LVEF (%)	■	■
Mean NT-proBNP (pg/ml)	■	■
Mean SBP (mmHg)	■	■
Proportion with eGFR <60 ml/min/1.73m ²	■	■

Abbreviations: BMI: body mass index; eGFR: estimated glomerular filtration rate; KCCQ: Kansas City Cardiomyopathy Questionnaire; LVEF: left ventricular ejection fraction; NT-proBNP: N-terminal pro-B-type natriuretic peptide; NYHA: New York Heart Association; SBP: systolic blood pressure; SE: standard error.
Source: DELIVER CSR.⁷⁸

Table 30: Patient medical history incorporated in the base case economic analysis

Patient characteristic	Mean	SE
Proportion with T2DM	■	■
Proportion with AFF	■	■
Proportion with most recent HHF >6 months	■	■
Proportion with most recent HHF ≤6 months	■	■
Proportion with HF duration >2 years	■	■

Abbreviations: AFF: atrial fibrillation/flutter; CKD: chronic kidney disease; HF: heart failure; HHF: hospitalisation for heart failure; SE: standard error; T2DM: type 2 diabetes mellitus.
Source: DELIVER CSR.⁷⁸

UK CPRD dataset

In a scenario analysis (see Section B.3.10.3), patient baseline characteristics were incorporated in the economic model based on the UK CPRD dataset for patients with HF and an LVEF >40% in the UK, as detailed in Table 31, Table 32 and Table 33 below.⁶² Where baseline characteristics were not available from the UK CPRD, the inputs from the DELIVER trial were used, as denoted above.⁷⁸

Table 31: Patient demographic characteristics based on the UK CPRD dataset used in a scenario analysis

Patient characteristic	Mean	SE	Source
Mean age (years)	■	■	UK CPRD ⁶²
Proportion male	■	■	UK CPRD ⁶²
Mean BMI (kg/m ²)	■	■	UK CPRD ⁶²
Race			
Proportion white	■	■	UK CPRD ⁶²
Proportion Black/African	■	■	UK CPRD ⁶²
Proportion other	■	■	UK CPRD ⁶²

Abbreviations: BMI: body mass index.
Source: UK CPRD dataset.⁶²

Table 32: Patient clinical characteristics based on the UK CPRD dataset used in a scenario analysis

Patient characteristic	Mean	SE	Sources
KCCQ quartiles			
Proportion in KCCQ-TSS Q1	■	■	DELIVER ⁷⁸
Proportion in KCCQ-TSS Q2	■	■	DELIVER ⁷⁸
Proportion in KCCQ-TSS Q3	■	■	DELIVER ⁷⁸
Proportion in KCCQ-TSS Q4	■	■	DELIVER ⁷⁸
Other clinical characteristics			
Mean LVEF (%)	■	■	UK CPRD ⁶²
Mean NT-proBNP (pg/ml)	■	■	UK CPRD ⁶²
Mean SBP (mmHg)	■	■	UK CPRD ⁶²
Proportion with eGFR <60 ml/min/1.73m ²	■	■	UK CPRD ⁶²

Abbreviations: BMI: body mass index; eGFR: estimated glomerular filtration rate; KCCQ: Kansas City Cardiomyopathy Questionnaire; LVEF: left ventricular ejection fraction; NT-proBNP: N-terminal pro-B-type natriuretic peptide; NYHA: New York Heart Association; SBP: systolic blood pressure; SE: standard error.

Source: UK CPRD dataset.⁶²

Table 33: Patient medical history based on the UK CPRD dataset used in a scenario analysis

Patient characteristic	Mean	SE	Source
Proportion with T2DM	■	■	UK CPRD ⁶²
Proportion with AFF	■	■	UK CPRD ⁶²
Proportion with most recent HHF >6 months	■	■	DELIVER ⁷⁸
Proportion with most recent HHF ≤6 months	■	■	DELIVER ⁷⁸
Proportion with HF duration >2 years	■	■	DELIVER ⁷⁸

Abbreviations: AFF: atrial fibrillation/flutter; CKD: chronic kidney disease; HF: heart failure; HHF: hospitalisation for heart failure; SE: standard error; T2DM: type 2 diabetes mellitus.

Source: UK CPRD dataset.⁶²

B.3.3.3. Health state transitions

Health state membership within the economic model was fully determined by time-dependent transition probabilities between health states. The transition probabilities between health states defined by KCCQ-TSS quartiles were derived using monthly transition count data from the DELIVER trial, assuming last observation carried forward (i.e., patients were assumed to remain in a KCCQ-TSS quartile until an observation indicating they had moved elsewhere).⁷⁸ Transition counts have a multinomial likelihood, which was combined with a flat Dirichlet prior distribution using Gibbs sampling to obtain the posterior probability distribution of the KCCQ-TSS transition matrix.

Treatment-specific transition probabilities were derived for the dapagliflozin in addition to SoC and placebo in addition to SoC arms of the DELIVER trial, respectively, as a statistically significant change in KCCQ-TSS was observed in the DELIVER trial (win ratio 1.11 [95% CI: 1.03, 1.21], p=0.009).⁷⁶ Given that KCCQ-TSS quartiles are used in this analysis to capture

disease progression, this result indicated an associated difference in disease progression between treatment with dapagliflozin in addition to SoC versus SoC alone, thereby validating the separation of transition probabilities.

Based on previous methods for modelling HF and an LVEF <40% (including dapagliflozin in the DAPA-HF trial on which the present analyses were based), disease progression trajectories were split between a phase spanning the first four months and a separate phase covering the remainder of the trial.^{1, 9, 112} The monthly probably of transition between health states defined by KCCQ-TSS quartiles is shown in Table 34.

Table 34: Monthly KCCQ-TSS transition matrix

KCCQ-TSS quartile transitions [From, To]	Dapagliflozin plus SoC				SoC			
	Months 1–4		Months 5+		Months 1–4		Months 5+	
	Mean	SE	Mean	SE	Mean	SE	Mean	SE
KCCQ [1, 1]	████	████	████	████	████	████	████	████
KCCQ [1, 2]	████	████	████	████	████	████	████	████
KCCQ [1, 3]	████	████	████	████	████	████	████	████
KCCQ [1, 4]	████	████	████	████	████	████	████	████
KCCQ [2, 1]	████	████	████	████	████	████	████	████
KCCQ [2, 2]	████	████	████	████	████	████	████	████
KCCQ [2, 3]	████	████	████	████	████	████	████	████
KCCQ [2, 4]	████	████	████	████	████	████	████	████
KCCQ [3, 1]	████	████	████	████	████	████	████	████
KCCQ [3, 2]	████	████	████	████	████	████	████	████
KCCQ [3, 3]	████	████	████	████	████	████	████	████
KCCQ [3, 4]	████	████	████	████	████	████	████	████
KCCQ [4, 1]	████	████	████	████	████	████	████	████
KCCQ [4, 2]	████	████	████	████	████	████	████	████
KCCQ [4, 3]	████	████	████	████	████	████	████	████
KCCQ [4, 4]	████	████	████	████	████	████	████	████

Abbreviations: KCCQ-TSS : Kansas City Cardiomyopathy Questionnaire-Total Symptom Score; SE: standard error; SoC: standard of care.

B.3.3.4. Treatment discontinuation

The probability of treatment discontinuation with dapagliflozin was derived from the DELIVER clinical trial and was applied as a constant probability of discontinuation to all patients receiving treatment with dapagliflozin in each modelled cycle. The annual probability of treatment discontinuation was █████ (SE: █████).⁷⁸ Following discontinuation of dapagliflozin, patients were assumed to continue receiving SoC alone, and experienced the same event rates, mortality and costs as patients in the SoC alone arm. This approach assumes that all treatment effect of dapagliflozin is instantly lost upon discontinuation and may therefore be considered a conservative assumption.

B.3.3.5. CV mortality and all-cause mortality

Evaluation of survival

Company evidence submission template for dapagliflozin for treating chronic heart failure with preserved or mildly reduced ejection fraction [ID1648]

The DELIVER trial provided observed survival data over a median follow-up of █ months with end-of-trial overall survival of █%.⁷⁸ To adopt a lifetime time horizon in the model, extrapolation beyond the trial period was required. The approach to survival modelling followed the extensive methods advocated by the NICE Decision Support Unit (DSU) Technical Support Documents (TSD) and published guidelines.¹¹³⁻¹¹⁵

Non-parametric evaluation of the DELIVER trial data was demonstrated with treatment-stratified Kaplan-Meier (KM) survival curves for CV mortality and all-cause mortality as illustrated in Figure 19 and Figure 20 respectively. The data were considered immature, as only a minority of patients died over the course of the trial, and median survival was █ for CV or all-cause mortality.^{76, 78}

When stratified by treatment arm, the KM curves for dapagliflozin in addition to SoC versus SoC alone followed a similar trajectory with overlapping and crossing of curves, possibly indicating a trial entry effect, before later differences emerged. The KM curves for dapagliflozin in addition to SoC versus SoC alone then demonstrated clear separation after one year for both CV and all-cause mortality (a larger separation was observed for CV mortality).

Figure 19: KM curves for CV mortality in the DELIVER trial, stratified by treatment

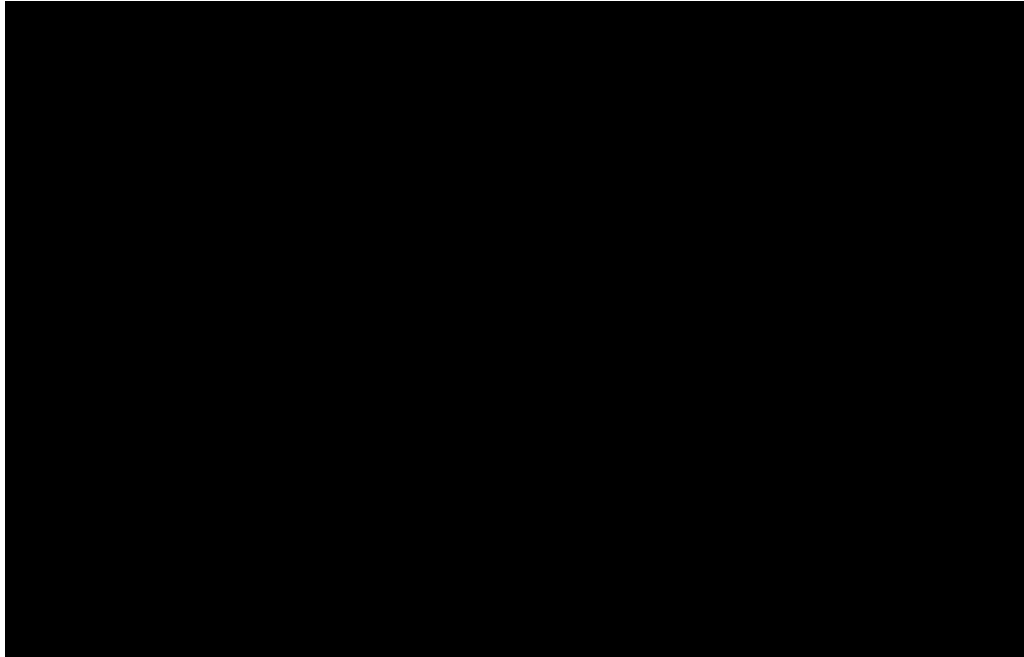

Abbreviations: CV: cardiovascular; KM: Kaplan-Meier.

Figure 20: KM curves for all-cause mortality in the DELIVER trial, stratified by treatment

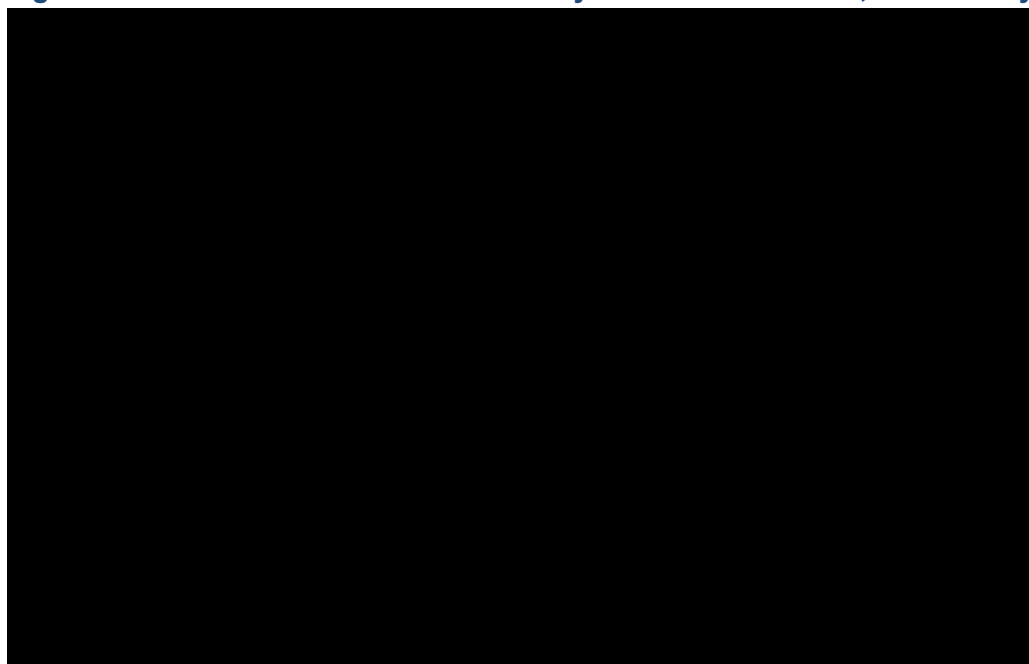

Abbreviations: KM: Kaplan-Meier.

For both CV mortality and all-cause mortality, dapagliflozin in addition to SoC was generally associated with a lower hazard than SoC alone (some overlap occurs in the early phases of the trial).

Hazard plots (presented in Appendix N.1.1) showed a general trend towards an increasing hazard of mortality over the course of the DELIVER trial, with a greater increase apparent for all-cause mortality compared with CV mortality, as expected with an aging trial population.

As such, it was considered that the parametric models used for CV and all-cause mortality should broadly reflect this trend in increasing hazards over time. An inflection point in the hazard trajectory was observed after approximately one year, with the hazards of mortality generally appearing to increase beyond this point.

Evaluation of relational models

Based on the evaluation of the survival and hazard profiles and in line with NICE DSU TSD14 guidance, the data were taken to be too complex to be represented with a single statistical model and therefore a piecewise approach was adopted. Diagnostic assessment informed the placing of a single split at one year to address the major inflection point and the change in hazard profile at this time point, while maximising the use of available data to inform the extrapolations. Suitability of the approach to address the proportional hazards (PH) assumption was confirmed by visual inspection and inferential testing, with p-values greater than 0.05 taken to indicate results consistent with the PH assumption. Full details of the PH assessments are presented in Appendix N.1.2.

Visual inspection of the log-cumulative hazard plots stratified by treatment arm showed general vertical parallelisation, which indicates that the PH assumption was valid. Log-cumulative hazard plots stratified by KCCQ-TSS quartiles were piecewise parallel, with deviations as described above, only in distinct follow-up phases. After application of the piecewise approach past one year, diagnostic plots of Schoenfeld residuals for models stratified by treatment and time-varying

KCCQ-TSS quartile suggested results were not inconsistent with the PH assumption as a function of time across the duration of the trial follow-up ($p=$ [REDACTED] for CV mortality and $p=$ [REDACTED] for all-cause mortality).

In addition to assessing for the PH assumption, accelerated failure time (AFT) models were also assessed using visual and statistical diagnostics. Visual inspection of the log-cumulative hazard plots stratified by treatment arm showed parallelisation on the horizontal plane being suggestive of AFT. No major deviations from linearity on the quantile-quantile plot suggested the data were not inconsistent with the AFT assumption. Where deviations did occur, these were observed at the extremes of the follow-up period, either within the first or last few months of the trial period.

Based on the assessment of PH and AFT, and in line with NICE DSU TSD14 guidance, a series of parametric models were deemed suitable to fit to the trial data.¹⁵ The exponential, generalised gamma, Gompertz, log-logistic, log-normal and Weibull distributions were all explored. Both adjusted and unadjusted models were considered in order to determine which would be most appropriate.

Unadjusted models

Initially, unadjusted survival models were explored, including only dapagliflozin as a variable in separating the survival extrapolations. The Akaike Information Criterion (AIC) and Bayesian Information Criterion (BIC) values for each of the unadjusted survival models for CV and all-cause mortality are presented in Table 35 and Table 36, below.

Table 35: AIC and BIC values of the unadjusted parametric survival model distributions for CV mortality derived from the DELIVER ITT population

Curve	AIC	AIC rank	BIC	BIC rank
Exponential	[REDACTED]	5	[REDACTED]	1
Generalised gamma	[REDACTED]	4	[REDACTED]	5
Gompertz	[REDACTED]	3	[REDACTED]	4
Log-logistic	[REDACTED]	2	[REDACTED]	3
Log-normal	[REDACTED]	6	[REDACTED]	6
Weibull	[REDACTED]	1	[REDACTED]	2

Abbreviations: AIC: Akaike Information Criterion; BIC: Bayesian Information Criterion; CV: cardiovascular; ITT: intention-to-treat.

Table 36: AIC and BIC values of the unadjusted parametric survival model distributions for all-cause mortality derived from the DELIVER ITT population

Curve	AIC	AIC rank	BIC	BIC rank
Exponential	[REDACTED]	6	[REDACTED]	6
Generalised gamma	[REDACTED]	3	[REDACTED]	4
Gompertz	[REDACTED]	4	[REDACTED]	3
Log-logistic	[REDACTED]	2	[REDACTED]	2
Log-normal	[REDACTED]	5	[REDACTED]	5
Weibull	[REDACTED]	1	[REDACTED]	1

Abbreviations: AIC: Akaike Information Criterion; BIC: Bayesian Information Criterion; ITT: intention-to-treat.

Adjusted models

Company evidence submission template for dapagliflozin for treating chronic heart failure with preserved or mildly reduced ejection fraction [ID1648]

To improve the statistical fit of the unadjusted survival models, a variable selection algorithm was followed to derive adjusted models, with the goal of minimising the AIC.

The null model was defined to consist of only the minimum factors required to inform mortality risk in any other adjusted model, namely the treatment arm and the KCCQ-TSS quartile health states. Using a forward stepwise approach, a list of candidate variables was derived based on the payer analysis plan (PAP) which was aligned to the statistical analysis plan (SAP) prepared by the AZ statistical team to partly inform variables considered for adjustment in survival analysis (which was validated and revised based on UK clinical expert opinion; Section B.3.13.3). These variables were added one-by-one to determine the greatest reduction in AIC, until either all candidate variables were included, or the addition of the next best variable resulted in an increase in the AIC, signalling a statistically poorer fit to the observed data.

All continuous variables were centred (i.e., a constant was subtracted from every value of each variable), in order to allow the intercept for each variable to be reflective of the mean value of each variable. The NT-proBNP values were naturally log transformed to reduce the breadth of range of values. However, unlike the other variables, NT-proBNP was not centred following the log transformation, due to the undefined range of negative values on the logarithmic scale.

The AIC and BIC scores for each distribution are presented in Table 37 and Table 38 for CV mortality and all-cause mortality respectively; full details of the coefficients for each of the adjusted parametric extrapolations for CV and all-cause mortality are presented in Appendix N.

Table 37: AIC and BIC values of the adjusted parametric survival model distributions for CV mortality derived from the DELIVER ITT population

Curve	AIC	AIC rank	BIC	BIC rank
Exponential	██████	6	██████	4
Generalised gamma	██████	2	██████	5
Gompertz	██████	4	██████	3
Log-logistic	██████	1	██████	1
Log-normal	██████	5	██████	6
Weibull	██████	3	██████	2

Abbreviations: AIC: Akaike Information Criterion; BIC: Bayesian Information Criterion; CV: cardiovascular; ITT: intention-to-treat.

Table 38: AIC and BIC values of the adjusted parametric survival model distributions for all-cause mortality derived from the DELIVER ITT population

Curve	AIC	AIC rank	BIC	BIC rank
Exponential	██████	6	██████	6
Generalised gamma	██████	2	██████	3
Gompertz	██████	4	██████	4
Log-logistic	██████	1	██████	1
Log-normal	██████	5	██████	5
Weibull	██████	3	██████	2

Abbreviations: AIC: Akaike Information Criterion; BIC: Bayesian Information Criterion; ITT: intention-to-treat.

Based solely on the statistical goodness-of-fit, the log-logistic, generalised gamma and Weibull distributions exhibit the lowest AIC and BIC for CV mortality and all-cause mortality, indicative of

Company evidence submission template for dapagliflozin for treating chronic heart failure with preserved or mildly reduced ejection fraction [ID1648]

the best fit to the observed data. Caution is advised when evaluating AIC and BIC goodness-of-fit statistics for survival models, as these measures only evaluate the strength of the model to the observed data and provide no information about the appropriateness of these extrapolations. Consultative input from clinicians was sought to further substantiate the clinical face validity of long-term survival projections.

The adjusted survival model extrapolations associated with CV mortality and all-cause mortality overlaid on the trial-based KM curves are presented in Figure 21 and Figure 22, respectively. For all-cause mortality, the log-normal and log-logistic distributions provide the most optimistic long-term survival predictions, with █% and █% of patients predicted to be alive at 25 years in the dapagliflozin arm. In contrast, the Gompertz and Weibull distributions predicted 25-year overall survival in the placebo arm to be █% and █%, respectively.

With a mean baseline age of █ for patients in the DELIVER trial, 25-year overall survival predictions of █% for dapagliflozin do not appear to be clinically plausible for a patient population aged █ at this point in the model. Survival estimates at 25 years that are closer to zero appear to be more clinically plausible and aligned with general population mortality expectations.

Figure 21: Adjusted survival model extrapolations for CV mortality^a

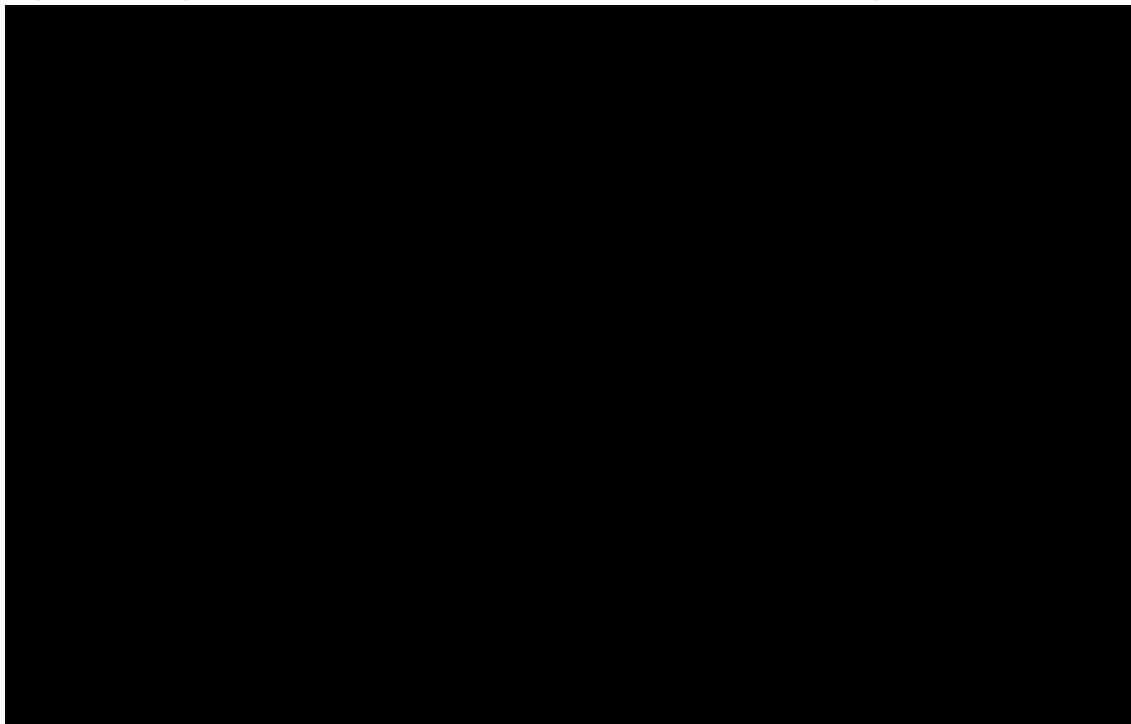

^aSurvival extrapolations are taken from the economic model to account for time-updated disease severity. Extrapolations include no application of general population mortality or non-CV mortality.

Abbreviations: CV: cardiovascular.

Figure 22: Adjusted survival model extrapolations for all-cause mortality^a

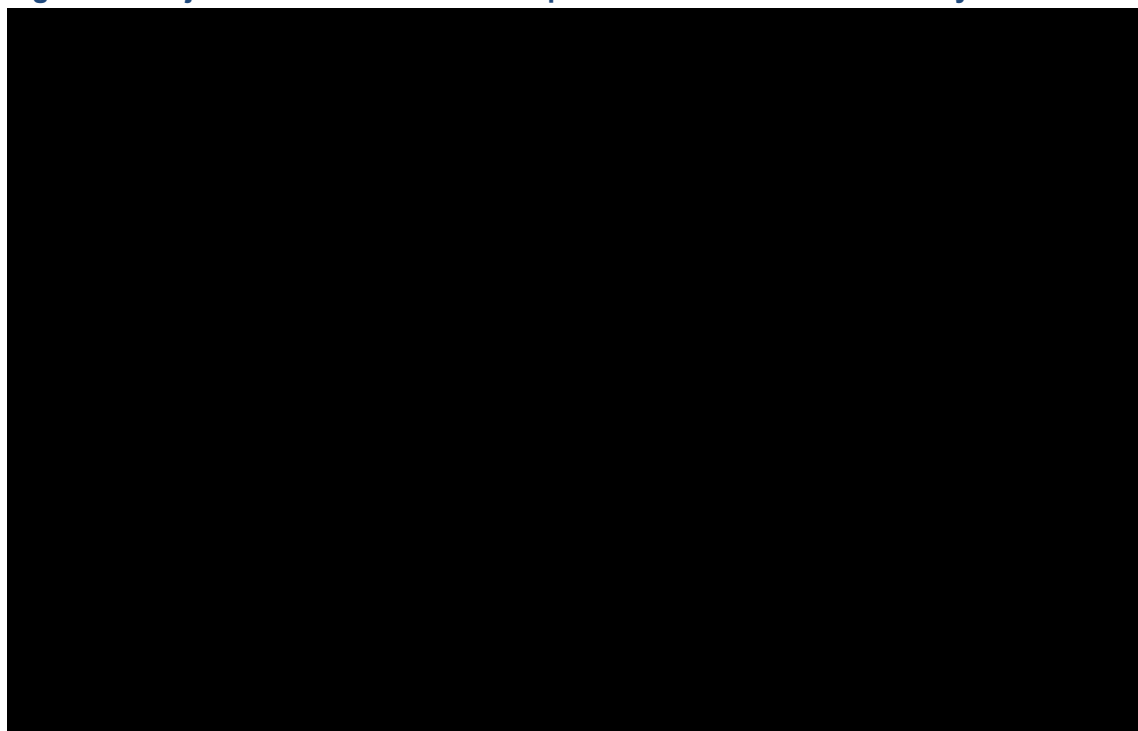

^aSurvival extrapolations are taken from the economic model to account for time-updated disease severity. Extrapolations include no application of general population mortality.

Validation of survival models

The predicted long-term estimates of survival for each of the extrapolations were compared with external sources, to inform the most appropriate distribution for survival to be used in the base case economic analysis. Historically, studies reporting outcomes in patients with HF and an LVEF $\leq 40\%$ are much more prevalent; there are fewer studies in the published literature reporting long-term outcomes for patients with HF and an LVEF $>40\%$.

An SLR and meta-analysis of studies of short- and long-term outcomes in HF patients presented in Jones *et al.* (2019) provided robust evidence in patients with HF across the spectrum of LVEF.¹¹⁶ The study identified two studies in patients with HF and an LVEF between 41%–49%, and 10 studies in patients with HF and an LVEF $\geq 50\%$ from which 5-year mortality was reported.

To facilitate a comparison between these study results and the base case economic model predictions, individual patient trial data from DELIVER were reweighted to align to the characteristics of the study population informing the summary estimate. In this instance only age was reweighted, using random effects estimation of the weights to inform the 5-year survival.

The adjusted survival predictions for all-cause mortality for patients receiving placebo overlaying the reweighted KM survival curve are presented in Figure 23. With the DELIVER trial having a maximum follow-up of ■ years, long-term validation was not possible as the meta-analysis only reported survival up to five years.

The meta-analysed mean survival at five years was 67%.¹¹⁶ All of the placebo survival extrapolations predicted 5-year survival estimates that fell within the 95% CI of the meta-analysed mean, with the exception of the Gompertz. The log-normal and exponential distributions appeared to be most closely aligned with the 5-year meta-analysed estimate of

mean survival.

However, both of these extrapolations were not considered to be clinically plausible. As previously detailed, the log-normal model resulted in 25-year estimates of survival that were considered to be clinically implausible, while the exponential distribution is associated with a constant hazard of mortality over time, which was also considered clinically implausible, as increasing age is known to be associated with an increasing hazard of mortality.

Figure 23: Adjusted all-cause mortality predictions for patients receiving placebo in the DELIVER trial compared with meta-analysed 5-year survival reported in Jones *et al.* (2019)^{116a}

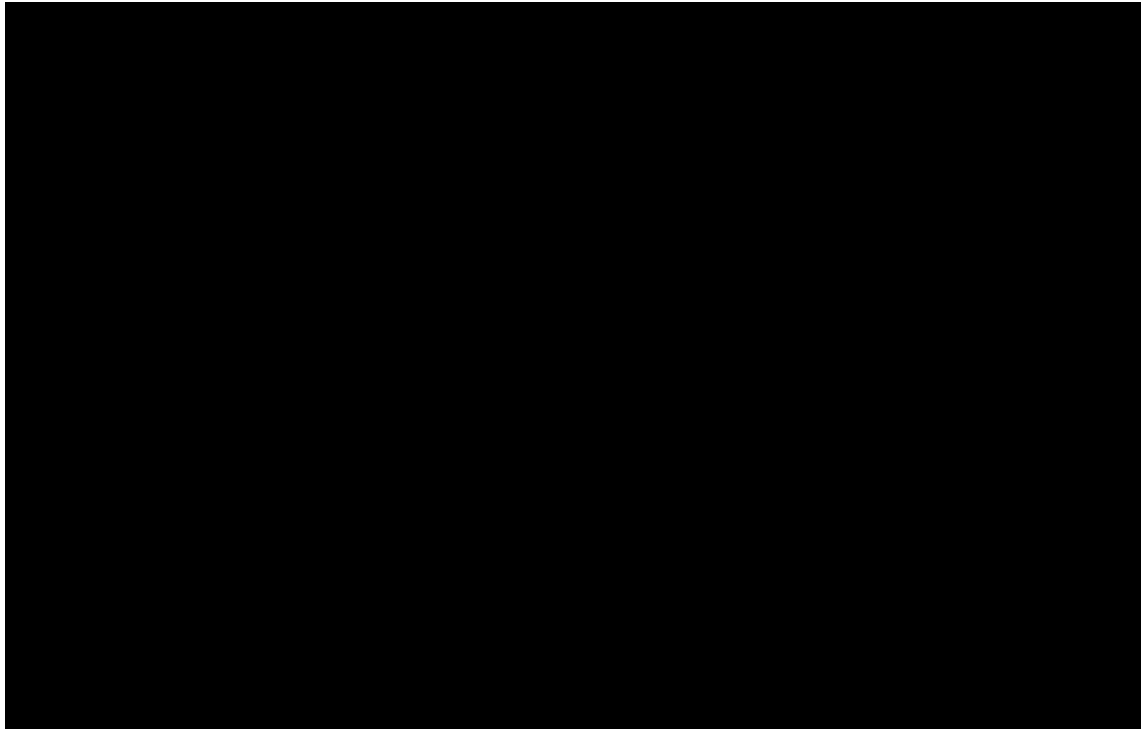

^aThe black dot and associated error bar relates to the reported 5-year survival in Jones *et al.* (2019)¹¹⁶; Extrapolations are presented only for the placebo arm.

In addition to the meta-analysis reported in Jones *et al.* (2019),¹¹⁶ a prospective, observational, multi-centre study by Shahim *et al.* (2021) investigated long-term mortality outcomes in 397 patients with complete follow-up in the community setting in Sweden and France.¹¹⁷ In this study, patients were enrolled after an acute HF event and had a mean baseline age of 78.¹¹⁷

In line with the comparison to Jones *et al.* (2019), the DELIVER individual patient trial data were re-weighted to align with the reported patient characteristics in Shahim *et al.* (2021).¹¹⁷ The re-weighted all-cause mortality KM curves and resulting extrapolations for the placebo arm in the DELIVER trial are presented in Figure 24 below, and compared with the reported survival predictions from Shahim *et al.* (2021).¹¹⁷

The survival estimates from Shahim *et al.* (2021) were generally below most of the parametric distributions.¹¹⁷ The Gompertz appeared to closely align at 5 years, however, appeared to substantially underestimate survival versus Shahim *et al.* (2021) from Year 10 onwards. The Weibull extrapolation appeared to represent the most reasonable extrapolation based on Shahim *et al.* (2021), closely aligned with the reported 10-year estimate of survival.¹¹⁷

Figure 24: Adjusted all-cause mortality predictions for patients receiving placebo in the DELIVER trial compared with long-term survival reported in Shahim *et al.* (2021)^{117a}

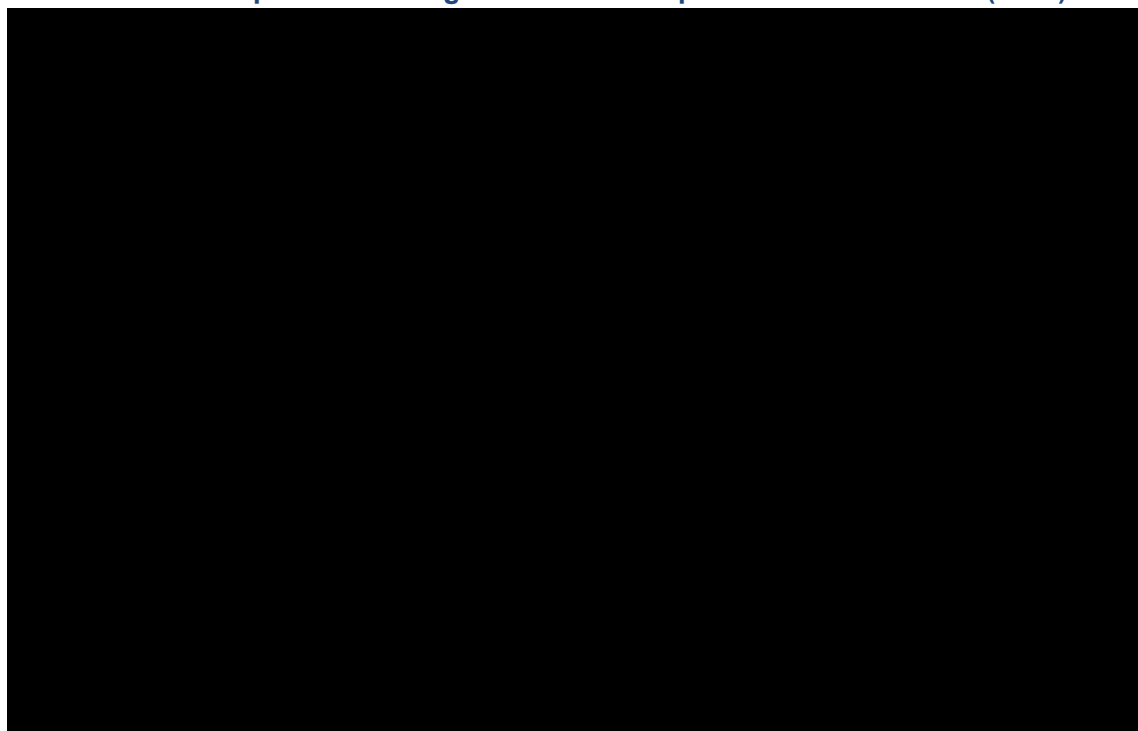

^aThe black dots relate to 1-, 3-, 5- and 10-year survival reported in Shahim *et al.* (2021). Survival model extrapolations are presented only for the placebo arm.

Selection of extrapolations for the base case economic analysis

Within the trial follow-up period, survival models exhibited very close alignment to the KM estimates of CV mortality and all-cause mortality. Considering AIC is a metric of goodness-of-fit, the top performing models, these being log-logistic, generalised gamma and Weibull, were statistically indistinguishable in the unadjusted models. Adjustments were devised according to an objective variable selection algorithm to identify parameters contributing to model fit, however minimisation of AIC only informed fit to the trial data and not long-term extrapolation.

External data in relevant patient populations were identified and the DELIVER trial data was adjusted to allow unbiased comparison with modelled survival predictions. A meta-analysis of studies for patients with HF and an LVEF >40% indicated a 5-year survival of 67%,^{116, 117} which was in line with exponential and log-normal distribution predictions (Figure 23). These distributions however exhibited the poorest fit to the trial data with the highest AIC and were therefore excluded from consideration. Furthermore, the exponential distribution was predicated on the assumption of constant hazard over time, and the log-normal distribution predicted implausible high long-term survival.

A further prospective, observational, multi-centre community-based study reported survival outcomes up to 10 years for patients with HF and an LVEF >40%.¹¹⁷ The reported survival outcomes from the study were generally below that of most distributions, although there was alignment with the Gompertz distribution at five years and the Weibull distribution at ten years (Figure 24). The Gompertz distribution was viewed to be an overestimation of mortality for the trial population, with the study-reported data based entirely on real world evidence (RWE), which could be viewed as a less healthy population than the DELIVER trial population. The Weibull presented as the next best fitting model for long-term predictions.

Overall, the Weibull distribution predictions fell within the uncertainty of the meta-analysis 5-year survival prediction and aligned with the 10-year observed survival reported in Shahim *et al.* (2021).¹¹⁷ As one of the best performing in terms of statistical goodness-of-fit in the adjusted and unadjusted survival models, the adjusted Weibull distribution was therefore considered to represent the most appropriate parametric distribution for modelling both CV and all-cause mortality in the base case economic analysis.

As detailed in Section B.3.13.3, two UK clinical experts were consulted as part of this appraisal and were asked to provide estimates of the most plausible long-term estimates of CV- and all-cause mortality. The clinicians indicated that the use of data in the published literature should be preferred to clinical expert opinion, however, both clinicians indicated that the Weibull extrapolation was considered plausible, supporting the selection of the Weibull extrapolation for the base case economic analysis.

Alternative adjusted and unadjusted parametric distributions were also considered in scenario analyses (Section B.3.10.3).

B.3.3.6. Non-CV mortality

Non-CV mortality risk was applied within the model by taking the maximum risk of:

- Non-CV mortality from the DELIVER trial (calculated as the difference in risks of all-cause and CV mortality)
- Non-CV mortality derived from general population life tables

The risk of non-CV mortality in the general population was calculated by adjusting the England and Wales 2017–2019 life tables using data reported by the World Health Organisation, describing age- and sex-stratified country-specific incident cases of CV mortality (presented in Table 39).^{106, 118} In line with NICE’s preferences, the England and Wales life tables used in the base case economic analysis were those from 2017–2019 rather than the more recent 2018–2020 life tables, in order to avoid the potential use of mortality data from 2020 that may be skewed by the COVID-19 pandemic.

Table 39: Age and sex-stratified mortality rates derived from WHO global health estimates

Age band	Male			Female		
	CV mortalities (per 100,000)	Population (per 100,000)	CV mortality rate	CV mortalities (per 100,000)	Population (per 100,000)	CV mortality rate
50–59	5.413785	4,498	0.001204	2.260814	4,641	0.000487
60–69	10.128038	3,527	0.002876	4.722829	3,679	0.001284
≥70	58.136578	4,078	0.014357	60.975000	5,014	0.012236

Abbreviations: CV: cardiovascular; WHO: World Health Organisation.

The rates of CV mortality are calculated using the following formula:

$$\text{Rate of CV death} = -\ln\left(1 - \frac{\text{Number of deaths from CV causes}}{\text{Total population}}\right)$$

The difference in rate of all-cause mortality and CV mortality was inferred to be the rate of non-

CV mortality. As a final step, the rate of non-CV mortality was converted to probabilities for use in the model using the following formula:

$$p = 1 - e^{-r}$$

Where p is the probability and r is the rate.

B.3.3.7. HF event incidence

The incidence of HF events (HHF and UHFV) were modelled using generalised estimating equations (GEE) due to the high frequency of recurrent events. An advent of a GEE beyond the constant hazard exponential estimations is the introduction of clustering for events occurring within the same individual. Additionally, this approach ensures that the economic analysis of the DELIVER trial captures the full impact of treatment with dapagliflozin for both first and subsequent events observed within the trial.

Two sets of equations are provided for the incidence of transient events; one fully adjusted for influential patient characteristics (hereby referred to as adjusted) and another adjusted only for dapagliflozin use (hereby referred to as unadjusted). For the adjusted GEEs, the use of patient characteristics allows the estimation of outcomes in patient subgroups to be captured via subgroup patient demographics and clinical characteristics. Conversely, for the unadjusted GEE, individual models are fitted to patient subgroups in order to derive parameters relevant only to those patients. Adjusted GEEs were used in the base case economic analysis; unadjusted GEEs were used in a scenario analysis.

Adjusted GEEs

For the adjusted GEEs, a variable selection algorithm was followed with the goal of minimising the quasi-information criterion (QIC). In the null model, the minimum separation between the modelled arms were included, these being the treatment arm and the KCCQ-TSS quartile health states. Using a forward stepwise approach, a list of candidate variables (were added one-by-one to determine the greatest reduction in QIC. The process was repeated until either all candidate variables were included or the addition of the next best variable resulted in an increase in the QIC, signalling a statistically poorer fit to the observed data.

All continuous variables were centred to allow the intercept to represent the case where the variables are at their mean value. The N-terminal pro-B-type natriuretic peptide (NT-proBNP) typically spans a large range and can be influenced by extremes (range: 237–31,290 pg/ml). To reduce the breadth of this range, the values for this covariate were naturally log transformed, resulting in a range of 5.47 to 10.35. These were then not centred, since centring first would yield negative values for which the logarithm is undefined.

The coefficients and statistics of the adjusted GEEs for predicting HF events are shown in Table 40 and Table 41 for HHF and UHFV, respectively. Whilst SEs are presented for each individual parameter included in the GEE, the economic model samples variables jointly using a variance-covariance matrix to allow for any correlations between parameters to be respected.

Table 40: Adjusted GEEs predicting HHF events

Covariate	Coefficient	SE	P-value
(Intercept)	████	████	████
Dapagliflozin	████	████	████

Age (years)	████	██	██
Sex: male	██	██	██
BMI (kg/m2)	████	██	████
Race: white	████	██	████
Race: black/African	██	██	██
Race: Other	████	██	████
KCCQ-TSS Q2	████	██	████
KCCQ-TSS Q3	████	██	████
KCCQ-TSS Q4	████	██	████
Log(NT-proBNP) (pg/ml)	██	██	████
eGFR (ml/min/1.73m ²)	██	██	██
T2DM	██	██	██
Baseline AFF	████	██	██
History of HHF: >6 months	██	██	████
History of HHF: ≤6 months	██	██	████

Abbreviations: AFF: atrial fibrillation/flutter; BMI: body mass index; CKD: chronic kidney disease; eGFR: estimated glomerular filtration rate; GEE: generalised estimating equation; HF: heart failure; HHF: hospitalisation for heart failure; KCCQ: Kansas City Cardiomyopathy Questionnaire; NYHA: New York Heart Association; SE: standard error; T2DM: type 2 diabetes mellitus; TSS: total symptom score; UHFV: urgent heart failure visit.

Table 41: Adjusted GEEs predicting UHFV events

Covariate	Coefficient	SE	P-value
(Intercept)	████	██	████
Dapagliflozin	████	██	████
Sex: male	██	██	████
BMI (kg/m2)	██	██	████
Race: white	████	██	████
Race: black/African	██	██	████
Race: Other	████	██	████
KCCQ-TSS Q2	████	██	████
KCCQ-TSS Q3	████	██	████
KCCQ-TSS Q4	████	██	████
Log(NT-proBNP) (pg/ml)	██	██	████
T2DM	██	██	████
Baseline AFF	████	██	████

Abbreviations: AFF: atrial fibrillation/flutter; BMI: body mass index; CKD: chronic kidney disease; eGFR: estimated glomerular filtration rate; GEE: generalised estimating equation; HF: heart failure; HHF: hospitalisation for heart failure; KCCQ: Kansas City Cardiomyopathy Questionnaire; NYHA: New York Heart Association; SE: standard error; T2DM: type 2 diabetes mellitus; TSS: total symptom score; UHFV: urgent heart failure visit.

Unadjusted GEEs

For the unadjusted GEEs used in a scenario analysis, only the use of dapagliflozin was used as a variable in determining the risk of event occurrence.

The coefficients and statistics of the unadjusted GEEs for predicting HF events are presented in Table 42. As for the adjusted GEEs, the economic model samples variables jointly using a variance-covariance matrix.

Table 42: Unadjusted GEE coefficients derived from the DELIVER trial

Parameter	HHF			UHFV		
Intercept	█	█	█	█	█	█
Dapagliflozin	█	█	█	█	█	█

Abbreviations: GEE: generalised estimating equation; HHF: hospitalisation for heart failure; ITT: intention-to-treat; SE: standard error; UHFV: urgent heart failure visit.

B.3.3.8. Adverse events

AEs which occurred with a frequency of >1% in the DELIVER trial were included within the base case economic analysis, based on the AE frequencies in Table 43.⁷⁸ Only AEs classified as serious were included to capture the most probable impact on healthcare resource use and patient's HRQoL.

Table 43. Adverse event frequency observed in DELIVER

Adverse event	Number of events	Number of patients	Frequency
AKI	█	█	█
Fracture	█	█	█
UTI	█	█	█
Volume depletion	█	█	█
Amputation	█	█	█
Major hypoglycaemia	█	█	█
Diabetic ketoacidosis	█	█	█
Genital infection	█	█	█

Abbreviations: AKI: acute kidney injury; UTI: urinary tract infection.

In addition to AEs >1%, amputation was additionally included as an AE of interest due to the historically suggested link between SGLT2 inhibitors and an increased risk of amputation, however it should be noted that a meta-analysis across the SGLT2 inhibitor class and RWE has suggested no statistically significant increase in risk.¹¹⁹

A summary of the modelled rates of AEs, based on the DELIVER trial, is provided in Table 44.

Each AE was associated with a utility decrement and a cost, as detailed in Section B.3.4.5 and B.3.5.4, respectively.

Table 44: Annual probability of AEs

Adverse events	Dapagliflozin plus SoC		SoC	
	Mean	SE	Mean	SE
AKI	█	█	█	█
Amputation	█	█	█	█
Fracture	█	█	█	█
UTI	█	█	█	█

Company evidence submission template for dapagliflozin for treating chronic heart failure with preserved or mildly reduced ejection fraction [ID1648]

Volume depletion	■	■	■	■
-------------------------	---	---	---	---

Abbreviations: AE: adverse event; AKI: acute kidney injury; SE: standard error; SoC: Standard of care; UTI: urinary tract infection.

B.3.4. Measurement and valuation of health effects

B.3.4.1. Health-related quality-of-life data from clinical trials

Health state utility values for each KCCQ-TSS quartile were derived from a pooled analysis of individual patient-level data from the DELIVER clinical trial. As per the trial protocol, responses from the EQ-5D-5L questionnaires were collected at baseline, eight months and final visit. Linear mixed effects regression models were fitted to predict patient reported utility values. Mixed effects models were used to account for repeated measures and within-patient correlation adjusted for time from baseline, sex, KCCQ-TSS quartile, T2DM at baseline, body mass index, and age.

EQ-5D-5L responses were mapped to EQ-5D-3L applying the mapping function developed by Hernandez Alava *et al.* (2017), making use of the Hernandez Alava *et al.* (2020) dataset assuming that reported domain scores within individual questionnaires were uncorrelated.^{103, 104} Health state utilities were subsequently estimated as marginal means to determine the utility associated with time spent in health state after adjusting for other patient characteristics. The resulting utility values are presented in Table 45.

An alternative scenario analysis was conducted where the utility value for KCCQ-TSS Q4 was set equal to the age-adjusted utility value in the general population, and the utility values for Q1–3 were derived by applying the decrements between Q1–Q3 and Q4 from the table below, to the general population utility value used for Q4 (see Section B.3.10.3).

Table 45: Health state utility values used in the base case economic analysis

Event	Mean	SE
KCCQ-TSS Q1	■	■
KCCQ-TSS Q2	■	■
KCCQ-TSS Q3	■	■
KCCQ-TSS Q4	■	■

Abbreviations: KCCQ: Kansas City Cardiomyopathy Questionnaire; SE: standard error; TSS: total symptom score.

Source: DELIVER CSR.⁷⁸

B.3.4.2. Mapping

As described above, EQ-5D-5L responses from the DELIVER trial were mapped to the EQ-5D-3L by applying the mapping function developed by Hernandez Alava *et al.* (2017), making use of the Economic Methods of Evaluation in Health and Social Care Policy Research Unit (EPRU) dataset (Hernandez Alava *et al.* [2020]) and assuming that reported domain scores within individual questionnaires were uncorrelated.^{103, 104}

B.3.4.3. Health-related quality-of-life studies

An economic SLR to identify relevant utilities studies conducted in patients with HF and an LVEF >40% was conducted in June 2022 and details of the methodology and results of this SLR are

presented in Appendix H.

In total, 9 articles reporting on 6 unique studies were included from the utilities studies SLR. A summary of the studies identified is provided in Appendix H.3.2; ultimately, as detailed in Appendix H.3.2, none of the studies identified were considered to provide relevant utility values for inclusion in the economic model.

B.3.4.4. HF events

Event utility decrements were used to capture the impact of HF events on HRQoL, based on the health state utilities derived from a linear mixed effects regression model using responses from the EQ-5D-5L questionnaires in the DELIVER trial, as detailed in Section B.3.4.1 (as detailed in Table 46).

Since these are transient events, they only occur once in the cycle of incidence, and as such a one-off utility decrement was applied in the same cycle to reflect the loss in HRQoL as a result of experiencing each event.

Table 46: Utility decrements used for HF events

HF event	Mean utility decrement	SE
HHF	■	■
UHFV	■	■

Abbreviations: HF: heart failure; HHF: hospitalisation for heart failure; SE: standard error; UHFV: urgent heart failure visit.

Source: DELIVER CSR.⁷⁸

B.3.4.5. Adverse reactions

Utility decrements were included within the economic model for AEs, and are presented in Table 47. In the absence of identifying any published utility decrement data within the economic SLR, alternative published sources from the literature were used, as described below.

The utility decrement for AKI was based on the results of the mixed effects regression models of utility on patients with CKD conducted as part of the DAPA-CKD trial.¹²⁰ The utility decrement for an amputation was based on results of an SLR for utilities in economic modelling of T2DM by Beaudet *et al.* (2014).¹²¹ The utility decrement for bone fractures and volume depletion was based on the outcomes of the mixed effects regression models conducted as part of the DAPA-HF trial and presented in McEwan *et al.* (2020).¹²²

Based on prior NICE appraisals of dapagliflozin in T2DM,⁵⁻⁷ a UTI was assumed to incur the same utility decrement in patients with T2DM as in patients with HF and an LVEF >40%. This decrement was derived from a published economic evaluation of interventions for UTIs in women by Barry *et al.* (1997).¹²³

Table 47. Utility decrements used for AEs

AE	Mean utility decrement	SE	Source
AKI	■	■	DAPA-CKD ¹²⁰
Amputation	-0.280	0.056	Beaudet <i>et al.</i> (2014) ¹²¹
Fracture	-0.149	0.033	McEwan <i>et al.</i> (2020) ¹²²

UTI	-0.003	0.001	Barry <i>et al.</i> (1997) ¹²³
Volume depletion	-0.051	0.012	McEwan <i>et al.</i> (2020) ¹²²

Abbreviations: AKI: acute kidney injury; SE: standard error; UTI: urinary tract infection.

B.3.4.6. Utility values used in the base case economic analysis

A summary of the utility values used in the base case economic analysis is provided in Table 48.

Table 48: Summary of utility values used in base case economic analysis

Health state/AE	Mean utility value	SE	Reference in submission	Source
Health state utility values				
KCCQ Q1	■	■	Section B.3.4.1	DELIVER CSR ⁷⁸
KCCQ Q2	■	■	Section B.3.4.1	DELIVER CSR ⁷⁸
KCCQ Q3	■	■	Section B.3.4.1	DELIVER CSR ⁷⁸
KCCQ Q4	■	■	Section B.3.4.1	DELIVER CSR ⁷⁸
Utility decrements for HF events				
HHF	■	■	Section B.3.4.5	DELIVER CSR ⁷⁸
UHFV	■	■	Section B.3.4.5	DELIVER CSR ⁷⁸
Utility decrements for AEs				
AKI	■	■	Section B.3.4.5	DAPA-CKD ¹²⁰
Amputation	-0.280	0.056	Section B.3.4.5	Beaudet <i>et al.</i> (2014) ¹²¹
Fracture	-0.149	0.033	Section B.3.4.5	McEwan <i>et al.</i> (2020) ¹²²
UTI	-0.003	0.001	Section B.3.4.5	Barry <i>et al.</i> (1997) ¹²³
Volume depletion	-0.051	0.012	Section B.3.4.5	McEwan <i>et al.</i> (2020) ¹²²

Abbreviations: AE: adverse event; AKI: acute kidney injury; CI: confidence interval; HHF: hospitalisation for heart failure; KCCQ: Kansas City Cardiomyopathy Questionnaire; SE: standard error; UHFV: urgent heart failure visit; UTI: urinary tract infection.

B.3.5. Cost and healthcare resource use identification, measurement and valuation

An economic SLR was conducted in June 2022 to identify relevant cost and resource use studies conducted in the UK for patients with HF and an LVEF >40%. Details of the methodology and results of this SLR are presented in Appendix I.

In total, 2 unique studies were included in the cost and resource use stream of the economic SLR. Neither of the studies provided relevant costs or resource use associated with dapagliflozin or the relevant comparator (SoC); as such, alternative costs and healthcare resource use estimates were identified based on previous NICE appraisals in HF, including TA679 for dapagliflozin in patients with HFpEF in particular.¹

B.3.5.1. Intervention and comparators' costs and resource use

As described throughout this submission, dapagliflozin is to be given as an add-on therapy to SoC. In the economic model, once patients discontinued treatment with dapagliflozin, they were assumed to cease to accrue any treatment-related costs of dapagliflozin and incurred the treatment costs of SoC alone.

Company evidence submission template for dapagliflozin for treating chronic heart failure with preserved or mildly reduced ejection fraction [ID1648]

The treatment cost for SoC was applied to both arms of the model and was based on the cost of treatment with a weighted average of 80% furosemide (40 mg orally once daily) and 20% bumetanide (1 mg orally once daily). These loop diuretics are the most commonly used SoC treatments in patients with HF and an LVEF >40% in UK clinical practice, based on UK clinical expert opinion. As detailed previously, the modelling of further additional therapies to treat comorbidities was not included, given the use of these therapies is expected to be the same for patients receiving dapagliflozin in addition to SoC and those receiving SoC alone. As any differences in costs for these therapies would therefore be negligible, it was not considered necessary to explicitly model these therapies.

The total cost of treatment in the dapagliflozin arm was derived as the sum of the cost of dapagliflozin plus the cost of SoC (Table 49).

As all therapies considered within the model are oral therapies, no treatment administration costs were applied within the model.

Table 49: Annual drug acquisition costs applied within the cost-effectiveness analysis

Treatment	Dose per tablet	Dosing schedule	Units per pack	Cost per pack	Annual cost	Source
SoC (furosemide)	40 mg	40 mg once daily	28	£0.14	£1.84	Cost: eMIT 2021 ¹⁰⁹ Dose: SmPC ¹¹⁰
SoC (bumetanide)	1 mg	1 mg once daily	28	£0.72	£9.39	Cost: eMIT 2021 ¹⁰⁹ Dose: SmPC ¹¹¹
Dapagliflozin	10 mg	10 mg once daily	28	£36.59	£477.30	Cost: BNF 2022 ¹² Dose: SmPC ⁸
Total annual cost (SoC) based on a weighted average of furosemide (80%) and bumetanide (20%)					£3.34	Calculation
Total annual cost (dapagliflozin plus SoC)					£480.64	Calculation

Abbreviations: BNF: British National Formulary; eMIT: electronic medicines information tool; SmPC: Summary of Product Characteristics; SoC: standard of care.

B.3.5.2. Clinical event costs

The impact of transient clinical events on direct healthcare costs was captured through the use of event costs. As transient events occur only in the cycle of incidence, similarly, a one-off event cost was applied in the same cycle. In addition to the transient events, the cost of mortality was also captured in the model. As for the transient events, this one-off cost was applied in the same cycle of mortality.

The event costs used in the model are presented in Table 50. The costs for HF events were sourced from the most recent version of NHS reference costs (2020/2021).¹⁰⁷ The cost of HHF was assumed to consist of non-elective long stay patients, with UHFV assumed to be day cases, consistent with UHFV being accident and emergency (A&E) visits without full hospitalisation (Table 50).

The cost of CV mortality was sourced from Alva *et al.* (2015), based on an analysis of the UK Prospective Diabetes Study (UKPDS) study.¹²⁴ Of the values reported in Alva *et al.* (2015), the cost associated with an MI was conservatively chosen as this was the lowest cost of the available fatal CV events (MI, stroke and IHD). The cost reported in Alva *et al.* (2015) was

inflated to the 2020/2021 cost year using the NHSCII indices published in the PSSRU.¹⁰⁸

The cost of non-CV mortality was sourced from Georghiou and Bardsley (2014), which represents a weighted average of the cost of GP visits (£147.00), district nursing care (£278.00), local authority-funded social care (£1,010.00) and hospital care (£4,580.00). These costs were inflated to the 2020/2021 cost year using the NHSCII indices published in the PSSRU.¹⁰⁸

Table 50: Event costs for transient events and mortality

Event	Mean	SE ^a	Source
HHF	£4,093.01	£818.60	NHS Reference Costs (2020/2021); ¹⁰⁷ Weighted average of EB03A:EB03E (non-elective long stay) <i>In line with the approach used in TA679¹</i>
UHFV	£737.68	£147.54	NHS Reference Costs (2020/2021); ¹⁰⁷ Weighted average of EB03A:EB03E (day case) <i>In line with the approach used in TA679¹</i>
CV mortality	£1,763.39	£516.08	Alva <i>et al.</i> (2015); ¹²⁴ Cost inflated to the 2020/2021 cost year using the NHSCII ^b <i>In line with the approach used in TA679¹</i>
Non-CV mortality	£4,792.39	£958.48	Georghiou and Bardsley (2014); ¹²⁵ Costs are inflated to the 2020/2021 cost year using the NHSCII ^c .

^aThe SE for HHF and UHFV are assumed to be 20% of the mean value. ^bThe cost of CV mortality has been inflated based on the NHSCII indices published in the PSSRU to derive the net present value. ^c The cost of non-CV mortality has been inflated based on the NHSCII indices published in the PSSRU to derive the next present value.

Abbreviations: CV: cardiovascular; HHF: hospitalisation for heart failure; NHS CII: National Health Service Cost Inflation Index; SE: standard error; UHFV: urgent heart failure visit.

B.3.5.3. Background health state unit costs and resource use

The annual health state costs associated with HF were sourced from McMurray *et al.* (2018), to capture GP visits, A&E referrals, cardiologist outpatient visits, and other outpatient visits.¹²⁶ Unit costs used in the McMurray *et al.* (2018) publication were updated using the latest PSSRU unit costs report (2021) and the latest NHS National Reference Costs (2020/2021).^{107, 108}

The resource use taken from McMurray *et al.* (2018) is aligned with TA679,¹²⁶ and it is acknowledged that this study included patients with HF and an LVEF ≤40%, representing a distinct patient population to those relevant to this appraisal. However, as no appropriate studies were identified describing the burden of disease associated with HF patients and an LVEF >40% in the economic SLR (see Appendix I.3), the use of McMurray *et al.* (2018) was considered to be the most appropriate source of disease management costs for this appraisal.

The annual health state costs are provided in Table 51, and were applied on a monthly basis to reflect the cycle length within the model. The background health state costs were constant across the different KCCQ-TSS quartile health states of the model. However, as described in Section B.3.3.7 the incidence and associated costs of clinical events was modelled separately for each health state.

Table 51: Health state resource use and frequency and unit costs

Resource group	Resource	Frequency (per year)	Unit cost	Source
----------------	----------	----------------------	-----------	--------

Company evidence submission template for dapagliflozin for treating chronic heart failure with preserved or mildly reduced ejection fraction [ID1648]

A&E visits	GP emergency visits	0.14	£39.00	McMurray <i>et al.</i> (2018) ¹²⁶
	A&E referrals	0.01	£170.46	
Outpatient office physician visits	GP visits	13.54	£39.00	
	Cardiologist visits	0.05	£191.12	
	Other physician visits	0.36	£39.00	
Other GP visits or contacts	GP home visits	1.23	£39.00	
	GP nursing home visits	0.19	£39.00	
	GP residential home visits	0.04	£39.00	
	GP phone calls to patients	0.73	£39.00	
	GP visits with third parties	7.27	£39.00	
Total mean annual cost (SE)^a		£927.76 (£185.55)		

^aSE assumed to be 20% of the mean value.

Abbreviations: A&E: accident and emergency; GP: general practitioner; SE: standard error.

Table 52: Unit costs used for health state costs

Resource	Unit cost	Description	Source
A&E referral	£170.46	Total outpatient attendance, service code 180: accident and emergency, total cost (consultant and non-consultant led).	NHS Reference Costs (2020/2021) ¹⁰⁷
GP visit	£39.00	Per surgery consultation lasting 9.22 minutes, with direct care staff costs, with qualification costs (Table 10.3b).	PSSRU (2021) ¹⁰⁸
Cardiologist visits	£191.12	Total outpatient attendance, service code 320: cardiology, total cost (consultant and non-consultant led).	NHS Reference Costs (2020/2021) ¹⁰⁷

Abbreviations: A&E: accident and emergency; GP: general practitioner; NHS: National Health Service; PSSRU: Personal Social Services Research Unit.

B.3.5.4. Adverse reaction costs

The unit costs for AEs included in the model are presented in Table 53. The costs of an AKI, amputation and fracture were sourced from the most recent version of the NHS Reference Costs (2020/2021).¹⁰⁷ All AEs were costed using non-elective long stay, reflective of the abruptness of SAEs, warranting a long stay under NHS resources. The costs for a UTI and volume depletion were assumed to consist of one visit to a general practitioner (GP).

Table 53: Unit costs for adverse events

Adverse event	Unit cost	SE ^a	Description	Source
AKI	£3,987.58	£797.52	Weighted average of non-elective long stay, currency code LA07H to LA07P.	NHS Reference Costs (2020/2021) ¹⁰⁷
Amputation	£17,267.42	£3,453.48	Weighted average of non-elective long stay, currency code YQ22A to YQ22B.	

Fracture	£5,212.21	£1,042.44	Weighted average of non-elective long stay, currency code HE11A to HE71D.	
UTI	£39.00	£7.80	Per GP surgery consultation lasting 9.22 minutes, with direct care staff costs, with qualification costs (Table 10.3b).	PSSRU (2021) ¹⁰⁸
Volume depletion				

^aAll SE assumed to be 20% of the mean value.

Abbreviations: AKI: acute kidney injury; GP: general practitioner; NHS: National Health Service; PSSRU: Personal Social Services Research Unit; SE: standard error; UTI: urinary tract infection.

B.3.5.5. Miscellaneous unit costs and resource use

All relevant costs have been captured in the above sections.

B.3.6. Severity

The expected quality-adjusted life expectancy (QALE) for the general population was calculated in line with the methods provided by Schneider *et al.* (2022).¹²⁷ The total life expectancy for the modelled population was calculated using England and Wales population mortality data from the ONS for 2017–2019,¹⁰⁶ and then quality-adjusted using UK population norm values for EQ-5D as reported by Hernández Alava *et al.* (2022) through the NICE DSU.¹²⁸

The total QALYs for the current UK population of patients with HF and an LVEF >40% was set equal to the QALYs associated with SoC alone in the base case economic analysis.

The absolute QALY shortfall and proportional QALY shortfall are shown in Table 54 and were below the threshold of 12 and 0.85, respectively, therefore a severity modifier of 1 was applied in the base case economic analysis.

Table 54: Summary features of QALY shortfall analysis

Factor	Value (reference to appropriate table or figure in submission)	Reference to section in submission
Sex distribution	████	Section B.3.3.2
Starting age	████	Section B.3.3.2

Abbreviations: QALY: quality adjusted life year.

Table 55: Summary of health state benefits and utility values for QALY shortfall analysis

State	Utility value: mean (SE)	Undiscounted life years
KCCQ-TSS Q1	████████	0.561
KCCQ-TSS Q2	████████	0.956
KCCQ-TSS Q3	████████	1.304
KCCQ-TSS Q4	████████	2.016

Abbreviations: KCCQ: Kansas City Cardiomyopathy Questionnaire; SE: standard error; TSS: total symptom score.

Table 56: Summary of QALY shortfall analysis

Expected total QALYs for the general population	Total QALYs that people living with a condition would be expected to have with current treatment	Absolute QALY shortfall	Proportional QALY shortfall
8.36	5.04	3.31	0.40

Abbreviations: QALY: quality-adjusted life year

B.3.7. Uncertainty

The majority of the model inputs included in the base case economic analysis have been robustly derived from the DELIVER trial, which provides head-to-head evidence for dapagliflozin in addition to SoC versus SoC alone, and are expected to be generalisable to patients in UK clinical practice.

The generalisability of the DELIVER trial has been explored in a scenario analysis, using alternative baseline characteristics from the UK CPRD dataset; other key modelling assumptions have also been tested in sensitivity and scenario analyses.

As such, the base case economic analysis should not be considered to be associated with a substantial level of uncertainty.

B.3.8. Summary of base case analysis inputs and assumptions

B.3.8.1. Summary of base case analysis inputs

A summary of the base case economic analysis inputs is presented in Table 57.

Table 57: Summary of variables applied in the economic model

Variable	Value	SE	Distribution	Reference
Age (years)	█	█	Normal	Section B.3.3.2
Proportion male	0.561	█	Beta	
BMI (kg/m ²)	█	█	Normal	
Race				
White	█	█	Beta	Section B.3.3.2
Black/African	0.025	█	Beta	
Other	█	█	Beta	
KCCQ quartiles				
Proportion in KCCQ-TSS Q1	█	█	Beta	Section B.3.3.2
Proportion in KCCQ-TSS Q2	█	█		
Proportion in KCCQ-TSS Q3	█	█		
Proportion in KCCQ-TSS Q4	█	█		
Other clinical characteristics				
LVEF (%)	█	█	Normal	Section B.3.3.2
NT-proBNP (pg/ml)	█	█	Normal	

Company evidence submission template for dapagliflozin for treating chronic heart failure with preserved or mildly reduced ejection fraction [ID1648]

Variable	Value	SE	Distribution	Reference
SBP (mmHg)	████	██	Normal	
Proportion with eGFR <60 ml/min/1.73m ²	████	████	Beta	
Proportion with T2DM	████	████	Beta	
Proportion with AFF	████	████	Beta	
Proportion with most recent HHF >6 months	████	████	Beta	
Proportion with most recent HHF ≤6 months	████	████	Beta	
Proportion with HF duration >2 years	████	████	Beta	
Monthly KCCQ-TSS transition matrix – Dapagliflozin + SoC: Months 1–4				
KCCQ [1, 1]	████	████	Beta	Section B.3.3.3
KCCQ [1, 2]	████	████		
KCCQ [1, 3]	████	████		
KCCQ [1, 4]	████	████		
KCCQ [2, 1]	████	████		
KCCQ [2, 2]	████	████		
KCCQ [2, 3]	████	████		
KCCQ [2, 4]	████	████		
KCCQ [3, 1]	████	████		
KCCQ [3, 2]	████	████		
KCCQ [3, 3]	████	████		
KCCQ [3, 4]	████	████		
KCCQ [4, 1]	████	████		
KCCQ [4, 2]	████	████		
KCCQ [4, 3]	████	████		
KCCQ [4, 4]	████	████		
Monthly KCCQ-TSS transition matrix – Dapagliflozin + SoC: Months 5+				
KCCQ [1, 1]	████	████	Beta	Section B.3.3.3
KCCQ [1, 2]	████	████		
KCCQ [1, 3]	████	████		
KCCQ [1, 4]	████	████		
KCCQ [2, 1]	████	████		
KCCQ [2, 2]	████	████		
KCCQ [2, 3]	████	████		
KCCQ [2, 4]	████	████		
KCCQ [3, 1]	████	████		
KCCQ [3, 2]	████	████		
KCCQ [3, 3]	████	████		
KCCQ [3, 4]	████	████		

Variable	Value	SE	Distribution	Reference
KCCQ [4, 1]	████	████		
KCCQ [4, 2]	████	████		
KCCQ [4, 3]	████	████		
KCCQ [4, 4]	████	████		
Monthly KCCQ-TSS transition matrix – SoC: Months 1–4				
KCCQ [1, 1]	████	████	Beta	Section B.3.3.3
KCCQ [1, 2]	████	████		
KCCQ [1, 3]	████	████		
KCCQ [1, 4]	████	████		
KCCQ [2, 1]	████	████		
KCCQ [2, 2]	████	████		
KCCQ [2, 3]	████	████		
KCCQ [2, 4]	████	████		
KCCQ [3, 1]	████	████		
KCCQ [3, 2]	████	████		
KCCQ [3, 3]	████	████		
KCCQ [3, 4]	████	████		
KCCQ [4, 1]	████	████		
KCCQ [4, 2]	████	████		
KCCQ [4, 3]	████	████		
KCCQ [4, 4]	████	████		
Monthly KCCQ-TSS transition matrix –SoC: Months 5+				
KCCQ [1, 1]	████	████	Beta	Section B.3.3.3
KCCQ [1, 2]	████	████		
KCCQ [1, 3]	████	████		
KCCQ [1, 4]	████	████		
KCCQ [2, 1]	████	████		
KCCQ [2, 2]	████	████		
KCCQ [2, 3]	████	████		
KCCQ [2, 4]	████	████		
KCCQ [3, 1]	████	████		
KCCQ [3, 2]	████	████		
KCCQ [3, 3]	████	████		
KCCQ [3, 4]	████	████		
KCCQ [4, 1]	████	████		
KCCQ [4, 2]	████	████		
KCCQ [4, 3]	████	████		
KCCQ [4, 4]	████	████		
Adjusted GEEs predicting HHF events				
(Intercept)	████	████	Normal	

Variable	Value	SE	Distribution	Reference
Dapagliflozin	████	████		Section B.3.3.7
Age (years)	████	████		
Sex: male	████	████		
BMI (kg/m ²)	████	████		
Race: white	████	████		
Race: black/African	████	████		
Race: Other	████	████		
KCCQ-TSS Q2	████	████		
KCCQ-TSS Q3	████	████		
KCCQ-TSS Q4	████	████		
Log(NT-proBNP) (pg/ml)	████	████		
eGFR (ml/min/1.73m ²)	████	████		
T2DM	████	████		
Baseline AFF	████	████		
History of HHF: >6 months	████	████		
History of HHF: ≤6 months	████	████		
Adjusted GEEs predicting UHFV events				
(Intercept)	████	████	Normal	Section B.3.3.7
Dapagliflozin	████	████		
Sex: male	████	████		
BMI (kg/m ²)	████	████		
Race: white	████	████		
Race: black/African	████	████		
Race: Other	████	████		
KCCQ-TSS Q2	████	████		
KCCQ-TSS Q3	████	████		
KCCQ-TSS Q4	████	████		
Log(NT-proBNP) (pg/ml)	████	████		
T2DM	████	████		
Baseline AFF	████	████		
CV Mortality and All-Cause Mortality				
Extrapolation for CV and All-Cause Mortality	Adjusted Weibull	█	N/A	Section B.3.3.5
Annual probability of AEs - Dapagliflozin + SoC				
AKI	████	████	Beta	Section B.3.3.8
Amputation	████	████		
Fracture	████	████		
UTI	████	████		
Volume depletion	████	████		
Annual probability of AEs - SoC				
AKI	████	████	Beta	

Variable	Value	SE	Distribution	Reference
Amputation	████	████		Section B.3.3.8
Fracture	████	████		
UTI	████	████		
Volume depletion	████	████		
Treatment discontinuation				
Dapagliflozin	████	████	Beta	Section B.3.3.4
Health state utility values				
KCCQ Q1	████	████	Beta	Section B.3.4.1
KCCQ Q2	████	████		
KCCQ Q3	████	████		
KCCQ Q4	████	████		
Utility decrements for HF events				
HHF	████	████	Beta	Section B.3.4.4
UHFV	████	████		
Utility decrements used for AEs				
AKI	████	████	Beta	Section B.3.4.5
Amputation	-0.280	0.056		
Fracture	-0.149	0.033		
UTI	-0.003	0.001		
Volume depletion	-0.051	0.012		
Annual treatment costs				
Annual cost of dapagliflozin	£477.30	N/A	N/A	Section B.3.5.1
Annual cost of SoC (based on an 80/20 split of furosemide/bumetanide)	£3.34	N/A	N/A	
Health state and event costs				
Background HF management, including costs of A&E visits and outpatient office physician visits	£927.76	£185.55	Gamma	Section B.3.5.2 and B.3.5.3
HHF	£4,093.01	£818.60		
UHFV	£737.68	£147.54		
CV mortality	£1,763.39	£516.08		
Non-CV mortality	£4,792.39	£958.48		
Unit costs for adverse events				
AKI	£3,987.58	£797.52	Gamma	Section B.3.5.4
Amputation	£17,267.42	£3,453.48		
Fracture	£5,212.21	£1,042.44		
UTI	£39.00	£7.80		
Volume depletion	£39.00	£7.80		

Abbreviations: A&E: accident and emergency; AFF: atrial fibrillation/flutter; AKI: acute kidney injury; BMI: body mass index; CV: cardiovascular; eGFR: estimated glomerular filtration rate; HF: heart failure; HHF: hospitalisation for heart failure; KCCQ-TSS: Kansas City Cardiomyopathy Questionnaire Total Symptom Score; LVEF: left

ventricular ejection fraction; SoC: standard of care; SBP: systolic blood pressure; T2DM: type 2 diabetes mellitus; UTI: urinary tract infection.

B.3.8.2. Assumptions

A summary of the base case economic analysis assumptions is presented in Table 58.

Table 58: Summary of assumptions in the base case economic analysis

Variable	Assumption	Justification	Scenarios conducted to explore uncertainty
Mortality	Adjusted survival extrapolations were limited to trial-based covariates.	The adjusted survival models used in the economic model were limited to covariates which were collected within the DELIVER trial. Whilst the impact is likely to be negligible, evidence from the literature suggests additional comorbidities, such as hyponatraemia and anaemia, have some effect on mortality. ¹¹⁷	No additional scenarios were conducted for this assumption. Any uncertainty surrounding modelling of mortality was explored through scenario analyses using alternative adjusted and unadjusted extrapolations (Section B.3.10.3).
Mortality; HF event incidence	No time-updated continuous variables were modelled.	Changes in BMI, LVEF, NT-proBNP and SBP over time were not modelled. This was not expected to have a material impact on the base case economic results, as changes in disease severity over time were instead captured by changes in KCCQ-TSS. The adjusted risk equations and survival models included covariates for KCCQ-TSS quartiles to capture the impact of disease severity on event risk and mortality.	No additional scenarios were conducted for this assumption. Any uncertainty surrounding mortality or HF incidence was explored through scenario analyses using alternative adjusted and unadjusted extrapolations (Section B.3.10.3).
Mortality; HF event incidence	The model used a 'mean of covariates' approach to modelling.	For the adjusted risk equations and survival extrapolations, the model used a 'mean of covariates' approach, whereby binary covariates were linearly scaled. For a cohort-based model, this assumption is commonplace, with the alternative of generating individual models for every combination of covariates cumbersome and unlikely to have a material impact.	No additional scenarios were conducted for this assumption specifically. Any uncertainty surrounding the risk equations and survival extrapolations was explored through scenario analyses using alternative adjusted and unadjusted extrapolations (Section B.3.10.3).
Mortality associated with AEs	No AE mortality was modelled.	The impact of AE-related mortality was not included as the model captures the impact of all-cause mortality, which inherently captures the mortality of adverse events. This is viewed as a conservative assumption, since the number of patients that experienced an AE-related death in the DELIVER trial was █████ in the placebo arm (████%) than in the dapagliflozin arm (████%). ⁷⁸	No additional scenario analyses were conducted for this assumption, although a range of scenarios exploring alternative extrapolations for mortality were explored.
Healthcare resource use	The healthcare resource use was based on a study of patients with HF and an LVEF ≤40% (McMurray <i>et al.</i> [2018]). ¹²⁶	No cost-effectiveness studies or appropriate burden of disease studies were identified to inform the healthcare resource use associated with patients with HF and an LVEF >40%, therefore the resource use was based on that of patients with HF and an LVEF ≤40%.	The healthcare resource use and costs were varied in the PSA and DSA (Section B.3.10.1 and B.3.10.2), in order to explore the uncertainty surrounded with these inputs in the base case economic analysis,

		This is likely to be an underestimation of the health state costs for patients with HF and an LVEF >40%, based on recent studies, which show that resource use for patients with HF and an LVEF >40% is typically higher than for patients with HF and an LVEF ≤40%. ¹²⁹	while an alternative scenario analysis sets the cost of non-CV mortality equal to CV mortality (Section B.3.10.3). No additional scenario analyses have been conducted.
Composition of SoC	The SoC for patients was assumed to be a weighted average of 40mg of furosemide per day (80%) and 1 mg bumetanide per day (20%).	Under current NICE guidance, the recommended treatment for patients with HF and an LVEF >40% consists of loop diuretics, such as furosemide and bumetanide. As such, a weighted average of these two treatments was assumed to represent SoC in the base case economic analysis.	No additional scenarios were conducted. Given the extremely similar costs of both furosemide and bumetanide, this is unlikely to have any meaningful difference on the base case economic analysis.
Dosage of furosemide	The dosage of furosemide was assumed to be 40 mg per day.	Under current NICE guidance, the recommended treatment for patients with HF and an LVEF >40% is a dose of less than 80mg per day of furosemide. At a negligible annual cost of £1.84, an increase to account for the maximum recommended dose of 80mg would result in a slightly higher annual cost (meaning that this assumption is likely to be conservative), but the impact on cost-effectiveness outcomes would be insignificant.	No additional scenarios were conducted for this assumption, given that this assumption is likely to be conservative, and any impact on cost-effectiveness would be insignificant.
Health state utility values	No impact of age on utility is modelled in the base case analysis.	The model uses health state utilities estimated through a linear fixed effects model to capture patients HRQoL. The health state utilities were derived whilst adjusting for patient characteristics, of which age has a coefficient of - [REDACTED]. The coefficient for impact of age on utility is considered extremely small and in a model predicting undiscounted life years of 7.8 for SoC, the impact of age is expected to be negligible.	A scenario analysis, where health state utility values were also age-adjusted over the model time horizon using UK population norm values for EQ-5D as reported in the HSE 2014 dataset by the NICE DSU. ¹²⁸
AE disutility	No trial-based utility data for AEs were used in the model.	No meaningful estimate of the impact of AEs on utility could be analysed due to a lack of routinely collected utility data in DELIVER trial. Instead, the impact of AEs on HRQoL was based on appropriately sourced inputs from the literature. As the incidence of AEs in the model is low, this is not expected to have a major impact on results.	AE disutility estimates were varied in the PSA and DSA (Section B.3.10.1 and B.3.10.2), in order to explore the uncertainty surrounding these inputs in the base case economic analysis. No additional scenario analyses have been conducted.

Abbreviations: AE: adverse event; BMI: body mass index; CV: cardiovascular; DSA: deterministic sensitivity analysis; HF: heart failure; HRQoL: health-related quality-of-life; LVEF: left ventricular ejection fraction; NT-proBNP: N-terminal pro-B-type natriuretic peptide; PSA: probabilistic sensitivity analysis; rEF: reduced ejection fraction; SBP: systolic blood pressure; SoC: standard of care.

B.3.9. Base case results

B.3.9.1. Base case incremental economic analysis results

The base case economic analysis results expressed in terms of incremental cost-effectiveness ratios (ICERs) and net health benefit (NHB) are presented in Table 59 and Table 60, respectively.

Over a lifetime horizon, treatment with dapagliflozin in addition to SoC, compared with SoC alone, was associated with increased life years (+0.369 per patient), increased QALYs (+0.250 per patient), at an incremental cost of +£1,880 per patient. Therefore, dapagliflozin in addition to SoC was highly cost-effective compared with SoC, with an ICER of £7,507/QALY gained. The net health benefit (NHB) associated with dapagliflozin in addition to SoC was 4.326 and 4.565 at willingness-to-pay (WTP) thresholds of £20,000 and £30,000/QALY gained, respectively.

Table 59: Base case economic analysis results – ICERs

Technologies	Total costs (£)	Total LYG	Total QALYs	Incremental costs (£)	Incremental LYG	Incremental QALYs	ICER (£/QALY)
Dapagliflozin plus SoC	£14,345	8.277	5.043	£1,880	0.369	0.250	£7,507
SoC	£12,465	7.908	4.793	-	-	-	

Abbreviations: ICER: incremental cost-effectiveness ratio; LYG: life years gained; QALYs: quality-adjusted life years.

Table 60: Base case economic analysis results – NHB

Technologies	Total costs (£)	Total QALYs	Incremental costs (£)	Incremental QALYs	NHB at £20,000/QALY	NHB at £30,000/QALY
Dapagliflozin plus SoC	£14,345	5.043	£1,880	0.250	4.326	4.565
SoC	£12,465	4.793	-	-	4.169	4.377

Abbreviations: ICER: incremental cost-effectiveness ratio; LYG: life years gained; QALYs: quality-adjusted life years; NHB: net health benefit.

B.3.10. Exploring uncertainty

B.3.10.1. Probabilistic sensitivity analysis

A PSA was performed to explore the effect of uncertainty associated with all model inputs. Three hundred PSA iterations were run to obtain stable estimates of the mean model results (as shown in Figure 27) and the mean total costs and mean total QALYs were calculated to estimate the probabilistic ICER.

In the PSA, all values were drawn from a distribution at the beginning of each simulated cohort in order to vary parameters that would otherwise remain fixed in the deterministic base case. Model input values were sampled from distributions around the mean value input parameters (used in the deterministic analysis), based on the SE associated with the input parameter. Where the SE was unavailable, the SE was assumed to be 20% of the mean.

In general, beta distributions were used for utilities, proportions and probability estimates, gamma distributions were used for costs, and normal distributions were used for the other parameters. Details on the parameters and SEs sampled in the PSA are provided in Section B.3.8.1.

The results of the base case PSA are presented in Table 32 below, with the scatterplot and cost-effectiveness acceptability curves presented in Figure 25 and Figure 26, respectively. The results show that dapagliflozin in addition to SoC had a 89.0% and 92.3% probability of being cost-effective at a WTP thresholds of £20,000 and £30,000/QALY gained, respectively.

Table 61: Base case PSA results

Technologies	Total costs (£)	Total QALYs	Incremental costs (£)	Incremental QALYs	ICER incremental (£/QALY)
Dapagliflozin plus SoC	£14,356	5.026	£1,879	0.246	£7,641
SoC	£12,477	4.780	-	-	-

Abbreviations: ICER: incremental cost-effectiveness ratio; QALYs: quality-adjusted life years; PSA: probabilistic sensitivity analysis.

Figure 25: Cost-effectiveness scatter plot from PSA

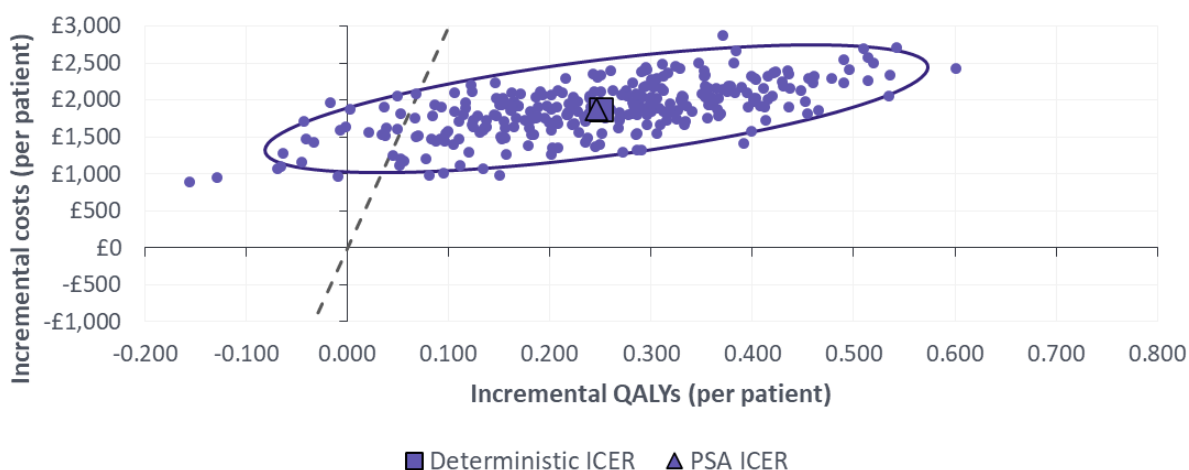

Abbreviations: ICER: incremental cost-effectiveness ratio; QALY: quality-adjusted life year; PSA: probabilistic

Company evidence submission template for dapagliflozin for treating chronic heart failure with preserved or mildly reduced ejection fraction [ID1648]

sensitivity analysis.

Figure 26: Cost-effectiveness acceptability curve from PSA

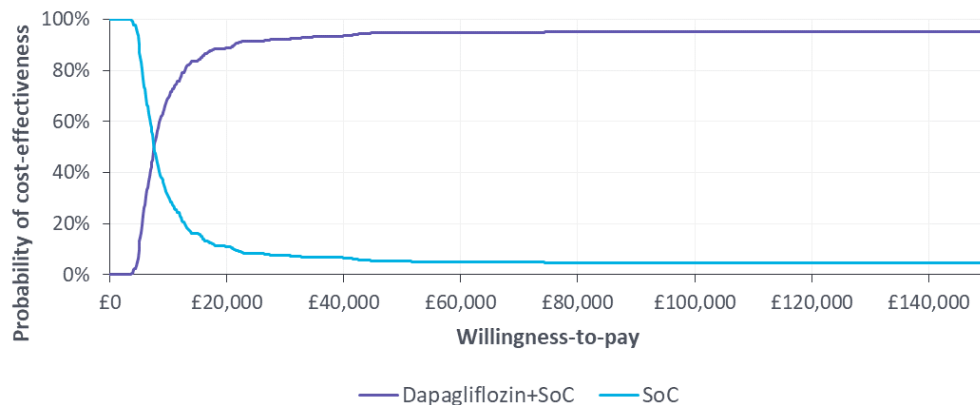

Abbreviations: PSA: probabilistic sensitivity analysis; SoC: standard of care.

Figure 27: ICER convergence plot from PSA

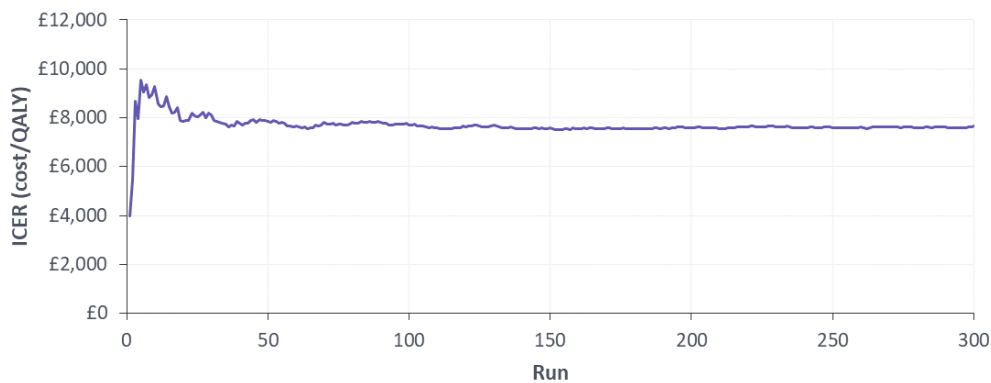

Abbreviations: ICER: incremental cost-effectiveness ratio; PSA: probabilistic sensitivity analysis.

B.3.10.2. Deterministic sensitivity analysis

Deterministic sensitivity analyses (DSA) were performed to explore the effect of uncertainty associated with varying individual model inputs or groups of individual model inputs. The DSA model inputs were varied based on the 95% CIs for each variable (95% CIs were calculated based on an SE assumed to be 20% from the mean if the 95% CIs weren't available). Variables which are dependent on other probabilities were generally excluded from the DSA, with the exception of the KCCQ-TSS transition probabilities, as these were considered to represent a core component of the model. Transition probabilities were included in the DSA by varying each parameter at a time, and scaling all other dependent parameters proportionately to ensure the transition probabilities cannot exceed 1 (100%) in any scenario.

The results of the DSA are summarised in Figure 28 below; the most influential factors on the DSA were the annual probability of amputation in the SoC and dapagliflozin in addition to SoC arms, and the event cost of HHF. However, the DSA showed that none of the included parameters had a substantial impact on the ICER, with all ICERs remaining below £9,000/QALY gained across the DSA scenarios.

Figure 28: Tornado plot of DSA results

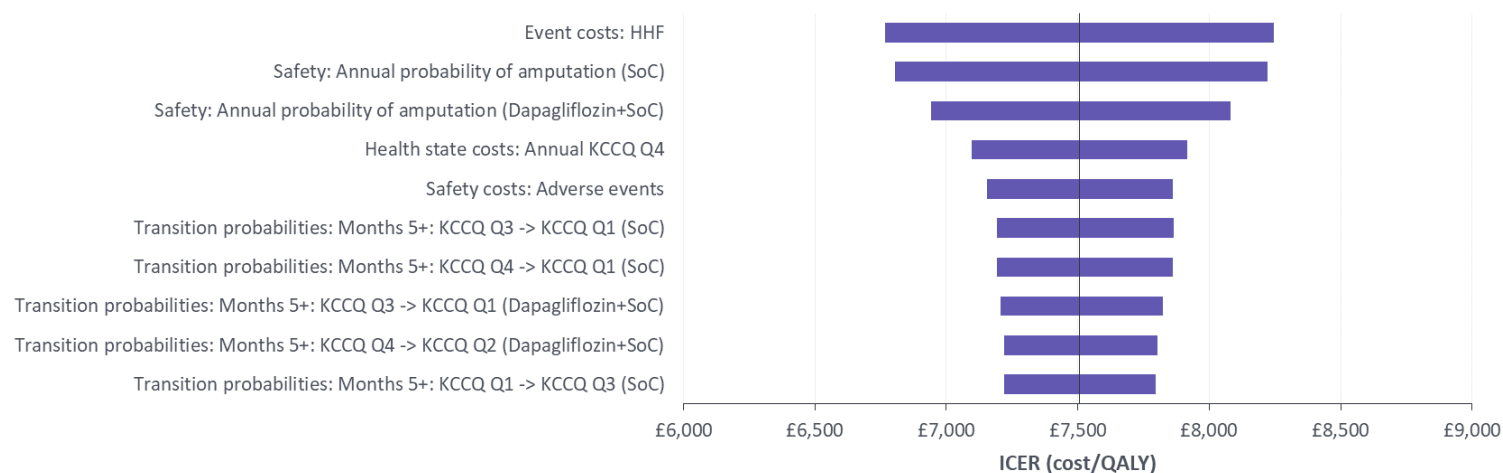

Abbreviations: DSA: deterministic sensitivity analysis; HHF: hospitalisation for heart failure; KCCQ-TSS: Kansas City Cardiomyopathy Questionnaire Total Symptom Score. NT-proBNP: N-terminal pro-B-type natriuretic peptide; SoC: standard of care.

B.3.10.3. Scenario analysis

A range of probabilistic scenario analyses were conducted to test the robustness of the model to alternative model inputs and assumptions. Each scenario was run with 300 probabilistic iterations as in the base case PSA. All of the scenarios supported the robustness of the base case ICER, with no scenarios associated with ICERs higher than £12,500/QALY gained. A description of each scenario analysis, as well as the probabilistic results of each scenario, are presented in Table 62.

Table 62: Summary of scenario analyses

#	Scenario analysis description	Base case input	Scenario analysis details	Results (for dapagliflozin plus SoC)		
				Incr. costs	Incr. QALYs	ICER
1	Baseline characteristics.	Baseline characteristics were derived from the ITT population in the DELIVER trial (Section B.3.3.2).	Baseline characteristics were derived from UK CPRD ⁶² for patients with HF and an LVEF >40%, as detailed in Section B.3.3.2. The UK CPRD provides baseline characteristics reflective of patients with HF and an LVEF >40% in UK clinical practice; characterising any uncertainty relating to the generalisability of the DELIVER trial to UK clinical practice. ¹⁰	£1,893	0.237	£7,988
2	Risk equations used to model HF events (HHF and UHFV).	Adjusted risk equations for HF events, including a range of covariates found to significantly impact the rate of HF events were utilised in the base case economic analysis, as detailed in Section B.3.3.7.	This scenario analysis used unadjusted risk equations for HF events, including only treatment as a covariate, were utilised, as detailed in Section B.3.3.7.	£1,872	0.246	£7,613
3	Risk equations used to model mortality.	Weibull distributions, adjusted for a range of covariates found to significantly impact mortality were used in the base case economic analysis for CV and all-cause mortality, as detailed in Section B.3.3.5.	Unadjusted Weibull distributions including only treatment as a covariate were utilised for CV and all-cause mortality, as detailed in Section B.3.3.5.	£1,762	0.189	£9,348
4	Parametric distributions for both CV-mortality and all-cause mortality.	The Weibull distribution was used for CV mortality and all-cause mortality in the base case economic analysis.	The exponential distribution was used to model both CV-mortality and all-cause mortality.	£2,149	0.294	£7,314
5			The log-normal distribution was used to model both CV-mortality and all-cause mortality.	£2,029	0.215	£9,445

6			The log-logistic distribution was used to model both CV-mortality and all-cause mortality.	£1,965	0.234	£8,406
7			The Gompertz distribution was used to model both CV-mortality and all-cause mortality.	£1,464	0.155	£9,439
8			The Generalised gamma distribution was used to model both CV-mortality and all-cause mortality.	£1,943	0.247	£7,852
9	General population mortality.	The survival estimates in the model were bounded by general population mortality (based on UK 2017–2019 life tables) in the base case economic analysis. Therefore the hazard of death could not be lower than the age-adjusted mortality for patients in the general population.	Survival estimates were not bounded by general population mortality to explore the impact of the approach taken in the base case economic analysis.	£1,882	0.248	£7,597
10	Utilities.	Utilities were not adjusted based on age in the base case economic analysis.	Health state utility values were also age-adjusted over the model time horizon using UK population norm values for EQ-5D as reported in the 2014 dataset by the NICE DSU. ¹²⁸	£1,879	0.234	£8,043
11	Cost of non-CV mortality.	The cost of non-CV mortality was £4,792.39, based on Georghiou and Bardsley (2014) (Section B.3.5.2). ¹²⁵	The cost of non-CV mortality was set equal to CV mortality.	£1,835	0.246	£7,461
12	Adverse events.	AEs were included for both dapagliflozin and SoC, as detailed in Section B.3.3.8.	It was assumed that no AEs were associated with SoC.	£2,774	0.225	£12,312
13	Utilities.	Health state utilities for each KCCQ-TSS quartile were based on HRQoL data from the DELIVER trial, as detailed in Section B.3.4.1.	The health state utility for KCCQ-TSS Q4 was assumed to be equal to general population utility; the relative decrements between KCCQ-TSS Q1–Q3 and Q4 based on the DELIVER trial data were applied to the general population utility to derive the	£1,879	0.225	£8,338

			<p>health state utility values for KCCQ-TSS Q1–Q3. The following KCCQ-TSS health state utilities were therefore used in the scenario:</p> <ul style="list-style-type: none"> • KCCQ-TSS Q1: [REDACTED] (SE: [REDACTED]); • KCCQ-TSS Q2: [REDACTED] (SE: [REDACTED]); • KCCQ-TSS Q3: [REDACTED] (SE: [REDACTED]); • KCCQ-TSS Q4: [REDACTED] (SE: [REDACTED]). 			
--	--	--	--	--	--	--

Abbreviations: AE: adverse event; CPRD: Clinical Practice Research Datalink; CV: cardiovascular; DSU: Decision Support Unit; EQ-5D: EuroQoL-5 Dimensions; HHF: hospitalisation for heart failure; HRQoL: health-related quality of life; ITT: intention-to-treat; KCCQ-TSS: Kansas City Cardiomyopathy Questionnaire – Total Symptom Score; LVEF: left ventricular ejection fraction; SE: standard error; SoC: standard of care; UHFV: urgent heart failure visit.

B.3.10.4. Summary of sensitivity analyses

The results of the probabilistic economic analysis were similar to the deterministic base case results, indicating that the economic model was robust to any uncertainties associated with model input parameters. The probabilities of cost-effectiveness for dapagliflozin at WTP thresholds of £20,000/QALY and £30,000/QALY gained were 89.0% and 92.3%, respectively. The most influential factors on the deterministic sensitivity analysis were the annual probability of amputation for both treatments and the cost of HHF, but overall dapagliflozin remained highly cost-effective compared with SoC alone with ICERs below £9,000/QALY gained in all DSA scenarios. Similarly, scenario analyses exploring alternative modelling assumptions and inputs showed that the base case economic analysis was robust, with ICERs below £12,500/QALY gained across all scenarios.

B.3.11. Subgroup analysis

No economic subgroup analyses were conducted as part of this appraisal.

B.3.12. Benefits not captured in the QALY calculation

The economic analysis has attempted to capture all of the potential benefits related to dapagliflozin within the QALY calculation. However, beyond those benefits included in the economic model, it is important to note that the availability of dapagliflozin for patients with HF and an LVEF >40% as part of this submission would mean that dapagliflozin is available for the entire spectrum of patients with HF in England and Wales, regardless of LVEF. As such, the introduction of dapagliflozin may allow greater alignment in the HF treatment pathway in the UK, and will allow HF specialists to more consistently utilise existing services to treat the whole spectrum of HF patients, resulting in efficiency gains within the NHS that are not captured within the QALY calculation.

B.3.13. Validation

In line with good practice guidelines on model transparency and validation, published by the International Society for Pharmacoeconomics and Outcomes Research (ISPOR),¹³⁰ the economic model was assessed for verification and internal validity versus the observed results in the DELIVER trial.

B.3.13.1. Model verification

Validation of the economic model structure was conducted by an independent expert health economist, not previously involved in the model conceptualisation or programming.¹³¹ Once fully developed, the model underwent two independent quality control and technical validation processes which included checking of all model calculations including standalone formulae, equations and Excel macros programmed in VBA. The correct functioning of the sensitivity and scenario analyses was also reviewed, and two checklists (for technical and stress test checks), based on the published TECH-VER checklist,¹³² were completed to ensure that the model generated accurate results which were consistent with input data and robust to extreme values.

B.3.13.2. Internal model validation

Internal validation is designed to assess whether outcomes from the model are consistent with the data sources used to inform model development, in this case the DELIVER trial. Internal

validation was undertaken for all modelled outcomes and for each subgroup.

Internal model validation for survival involved a comparison for the modelled survival estimates, versus the survival estimates observed during DELIVER for CV- and all-cause mortality. The validation of survival in the ITT population is presented in Figure 29. As the observed survival from DELIVER is unadjusted for covariate effects, modelled outcomes are presented using unadjusted models to present an unbiased comparison.

Figure 29: Internal validation of survival for the DELIVER ITT population^a

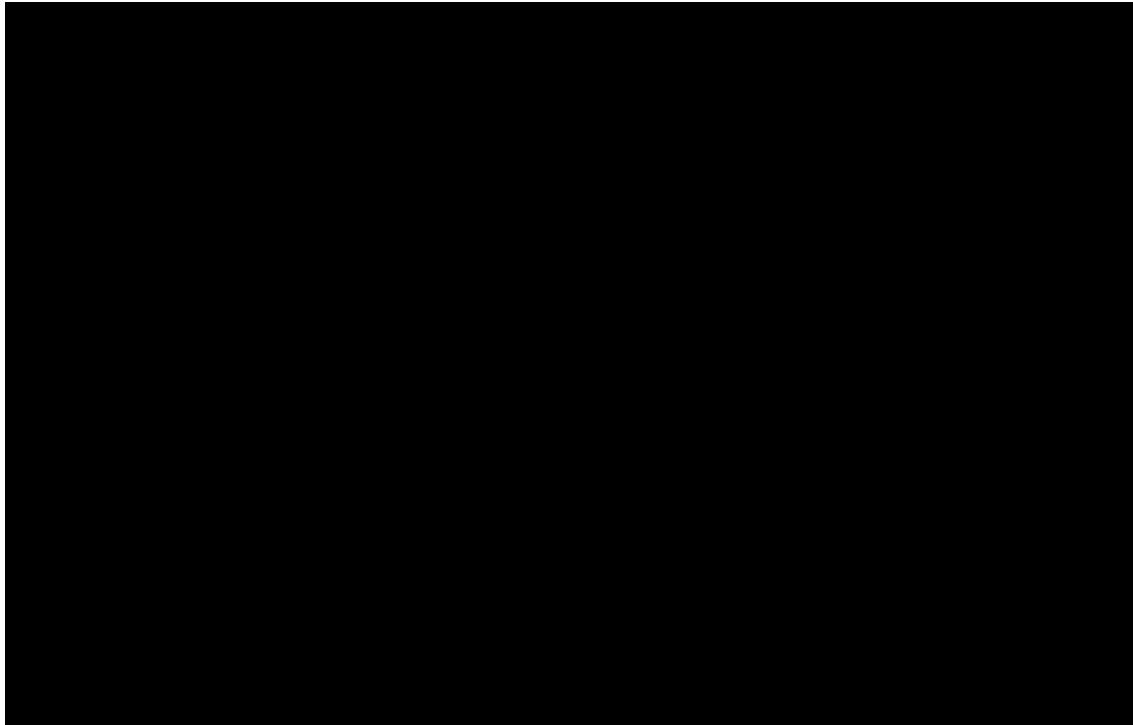

^aSolid lines are the Kaplan-Meier from DELIVER; dashed lines are the outcomes from the model.

Abbreviations: CV: cardiovascular; ITT: intention-to-treat; SoC: standard of care.

Internal model performance for event rates was evaluated by visualising the concordance of observed event rates from DELIVER versus predicted events rates from the model and calculating goodness-of-fit statistics. The 45° identity line demonstrates how well predicted event rates compared to reported event rates, with comparisons falling below the line indicative of underprediction and conversely, comparison above the line indicative of overprediction. An ordinary least squares regression line was fitted to the event rates to derive an estimate of the slope. A slope of 1 indicates full concordance between the predicted and published event rates; however, a slope of less than 1 and greater than 1 is indicative of underprediction and overprediction, respectively.

To quantify the magnitude of strength in the validation outcomes to the fitted regression line a goodness-of-fit statistical measure in the form of the R^2 value is calculated. To quantify the model predictivity, goodness-of-fit assessments are calculated. The selected goodness-of-fit statistics are:

- Mean absolute percentage error (MAPE)
- Root mean square percentage error (RMSPE)
- Mean squared log of the accuracy ratio (MSLAR)
- Mean squared logit error (MSLE)

The comparison of the predicted event rates from the model versus the observed event rates from DELIVER are presented Figure 30 for the ITT population. As the observed event rates from DELIVER are unadjusted for covariate effects, a comparison using the unadjusted risk equations and survival are presented to fairly demonstrate concordance. The regression lines are almost identical to the 45° identity line, indicating strong predictive strength in the model outcomes.

Figure 30: Internal validation of predicted versus observed event rates for the DELIVER ITT population^a

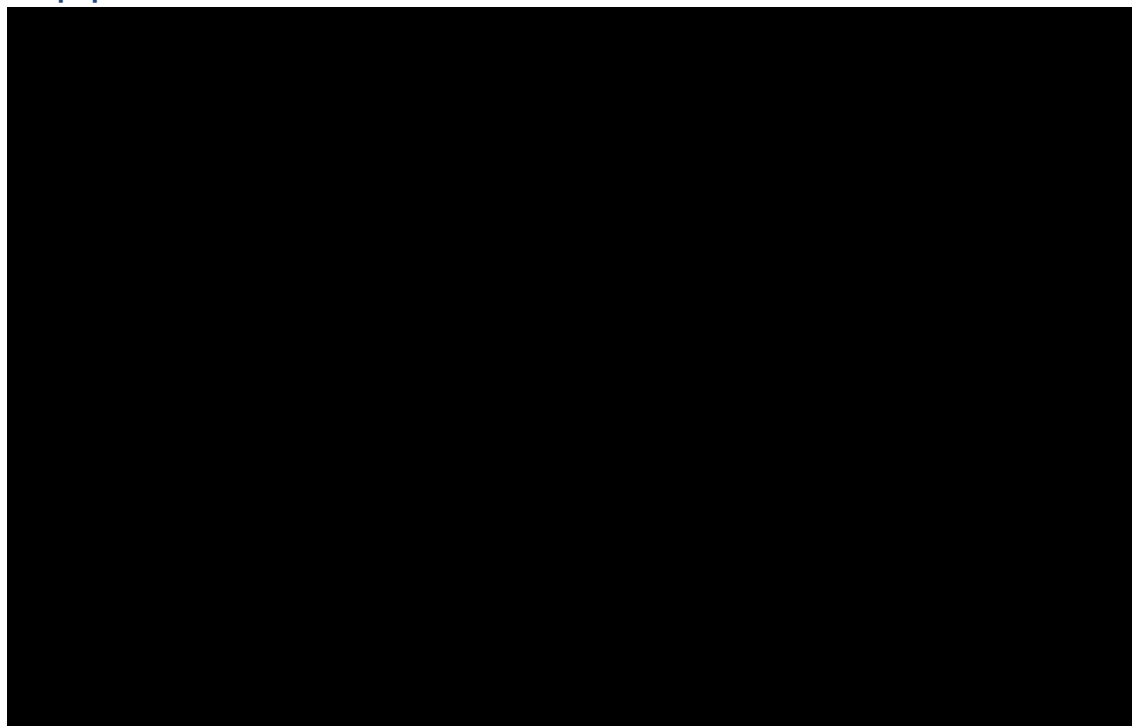

^aSolid line is the 45° identity line; dashed line is the regression line; grey shaded area is the 95% CI for the regression line.

Abbreviations: ACD: all-cause death; CV: cardiovascular; HHF: hospitalisation for heart failure; ITT: intention-to-treat; UHFV: urgent heart failure visit.

The regression slope and goodness-of-fit statistics for the ITT population and subgroups are presented in Table 63. The regression slopes of ■■■ indicates a mild overprediction of event rates. An R² of exactly ■ indicates showing the strength of the regression line to the predicted event rates. The other goodness-of-fit statistics showed only mild deviation, again indicating the strength of the model at reproducing observed event rates.

Table 63. Statistics from the internal validation of event rates

Population	Regression slope	Goodness-of-fit statistics				
		R ²	MAPE	RMSPE	MSLAR	MSLE
ITT population	■■■	■■■	■■■	■■■	■■■	■■■

Abbreviations: ITT: intention-to-treat; MAPE: mean absolute percentage error; MSLAR: mean squared log of the accuracy ratio; MSLE: mean squared logit error; RMSPE: root mean squared percentage error.

B.3.13.3. Clinical expert model validation

Two UK clinical experts experienced in the management of patients with HF and an LVEF >40% were consulted as part of the development of the economic model.

Company evidence submission template for dapagliflozin for treating chronic heart failure with preserved or mildly reduced ejection fraction [ID1648]

Candidate variables for adjusted survival and risk equations

The clinical experts were asked to provide feedback on the modelling approaches for CV-mortality, all-cause mortality and the adjusted risk equations for HF events. The initial proposed list of candidate variables to be included in the adjusted survival and risk equations were presented to both experts, and the final list of variables under consideration was revised based on the expert feedback.

As detailed in Section B.3.3.5 and Section B.3.3.7, the finalised list of candidate variables was then assessed based on statistical fit, to determine the variables that were adjusted for in the final adjusted models.

Plausible estimates of survival

The clinical experts were asked to provide estimates of the most plausible proportions of patients who would be alive after 5, 10, 15 and 20 years, respectively, based on either CV-mortality or all-cause mortality. However, the experts generally indicated that the use of data in the published literature to inform the most plausible estimates of survival would be a more robust approach to select the most appropriate curves for the base case analyses, rather than using clinical expert estimates of survival. Both experts indicated that the Weibull extrapolation used in the base case analyses could be considered plausible.

B.3.14. Interpretation and conclusions of economic evidence

The economic model used a Markov cohort model structure with health states based on KCCQ-TSS scores, and the analysis was consistent with the NICE reference case, taking an NHS and PSS perspective

Model inputs were mainly derived from the DELIVER trial, including inputs for baseline characteristics, health state transition probabilities, the probability of treatment discontinuation, health state utility values, risk equations and AE incidence rates. Additional model inputs for AE utility decrements, treatment costs, unit costs and resource use were identified from the literature or from NHS National Reference Costs.

In the base case economic analysis, dapagliflozin was found to be highly cost-effective as an add-on therapy to SoC for the treatment of patients with HF and an LVEF >40% versus SoC alone, with SoC defined as loop diuretics (furosemide and bumetanide). Treatment with dapagliflozin in addition to SoC was associated with increased life years (+0.369 per patient), increased QALYs (+0.250 per patient), at an incremental cost of +£1,880 per patient, compared with SoC alone. Therefore, dapagliflozin in addition to SoC was highly cost-effective compared with SoC, with an ICER of £7,507/QALY gained.

The results of the sensitivity analyses indicated that the model was robust to any uncertainties associated with model input parameters. The probabilities of cost-effectiveness for dapagliflozin at WTP thresholds of £20,000/QALY and £30,000/QALY gained were 89.0% and 92.3%, respectively. Dapagliflozin remained highly cost-effective compared with SoC across deterministic sensitivity analysis scenarios and the scenario analyses exploring alternative modelling assumptions and inputs, with ICERs below £12,500/QALY gained across all scenarios.

In summary, the economic analysis showed that dapagliflozin represents a highly cost-effective use of NHS resources, as an add-on therapy to SoC for the treatment of patients with HF and an LVEF >40%.

Company evidence submission template for dapagliflozin for treating chronic heart failure with preserved or mildly reduced ejection fraction [ID1648]

References

1. National Institute for Health and Care Excellence (NICE). Dapagliflozin for treating chronic heart failure with reduced ejection fraction [TA679]. Available at: <https://www.nice.org.uk/guidance/ta679> [accessed 28 April 2022]. 2021.
2. Henning RJ. Diagnosis and treatment of heart failure with preserved left ventricular ejection fraction. *World J Cardiol.* 2020;12(1):7-25.
3. McDonagh TA, Metra M, Adamo M, et al. 2021 ESC Guidelines for the diagnosis and treatment of acute and chronic heart failure. *European Heart Journal.* 2021:1-128.
4. AstraZeneca UK Ltd. Data on File. ID: REF-156527 [Loop diuretic standard care in HFpEF/mrEF in England]. 2022.
5. National Institute for Health and Care Excellence (NICE). Canagliflozin, dapagliflozin and empagliflozin as monotherapies for treating type 2 diabetes [TA390]. Available at: <https://www.nice.org.uk/guidance/ta390> [accessed 01 June 2022]. 2016.
6. National Institute for Health and Care Excellence (NICE). Dapagliflozin in triple therapy for treating type 2 diabetes [TA418]. Available at: <https://www.nice.org.uk/guidance/ta418> [accessed 01 June 2022]. 2016.
7. National Institute for Health and Care Excellence (NICE). Dapagliflozin in combination therapy for treating type 2 diabetes [TA288]. Available at: <https://www.nice.org.uk/guidance/ta288> [accessed 01 June 2022]. 2016.
8. Electronic Medicines Compendium (EMC). Forxiga 10 mg film-coated tablets [SmPC]. Available at: <https://www.medicines.org.uk/emc/product/7607/smpc> [accessed 08 June 2022]. May 2022.
9. National Institute for Health and Care Excellence (NICE). Dapagliflozin for treating chronic kidney disease [TA775]. Available at: <https://www.nice.org.uk/guidance/ta775> [accessed 01 June 2022]. 2022.
10. AstraZeneca UK Ltd. Data on File. ID: REF-151249 [Summary of clinician interviews to support the NICE HTA submission for HFpEF]. 2022.
11. National Institute for Health and Care Excellence (NICE). Dapagliflozin for treating chronic heart failure with preserved or mildly reduced ejection fraction [Final Scope]. Available at: <https://www.nice.org.uk/guidance/indevelopment/gid-ta10942/documents> [accessed 31 August 2022]. 2022. 2022.
12. British National Formulary (BNF). Dapagliflozin Medicinal Form. Available from: <https://bnf.nice.org.uk/medicinal-forms/dapagliflozin.html>. [accessed 28 April 2022].
13. Monthly Index of Medical Specialities (MIMS). Available at: <https://www.mims.co.uk/drugs/diabetes/oral-and-parenteral-hypoglycaemics/forxiga> [Last accessed 28 April 2022].
14. Savarese G, Becher PM, Lund LH, et al. Global burden of heart failure: A comprehensive and updated review of epidemiology. *Cardiovasc Res.* 2022.
15. Ponikowski P, Voors AA, Anker SD, et al. 2016 ESC Guidelines for the diagnosis and treatment of acute and chronic heart failure: The Task Force for the diagnosis and treatment of acute and chronic heart failure of the European Society of Cardiology (ESC). Developed with the special contribution of the Heart Failure Association (HFA) of the ESC. *Eur J Heart Fail.* 2016;18(8):891-975.
16. Edelmann F, Stahrenberg R, Gelbrich G, et al. Contribution of comorbidities to functional impairment is higher in heart failure with preserved than with reduced ejection fraction. *Clinical Research in Cardiology.* 2011;100(9):755-764.
17. Comin-Colet J, Martin Lorenzo T, Gonzalez-Dominguez A, et al. Impact of non-cardiovascular comorbidities on the quality of life of patients with chronic heart failure: a scoping review. *Health Qual Life Outcomes.* 2020;18(1):329.
18. Lang CC, Mancini DM. Non-cardiac comorbidities in chronic heart failure. *Heart.* 2007;93(6):665-671.
19. Metra M, Zaca V, Parati G, et al. Cardiovascular and noncardiovascular comorbidities in patients with chronic heart failure. *J Cardiovasc Med (Hagerstown).* 2011;12(2):76-84.
20. Chioncel O, Lainscak M, Seferovic PM, et al. Epidemiology and one-year outcomes in patients with chronic heart failure and preserved, mid-range and reduced ejection fraction: an analysis of the ESC Heart Failure Long-Term Registry. *European Journal of Heart Failure.* 2017;19(12):1574-1585.

21. Banerjee A, Bodegard J, Mamza JB, et al. Heart Failure Prevalence, Patient Characteristics and Outcomes: A Large Observational Study. Presentation at ESC-HF 2020. ESC-HF 2020. Virtual 2020.
22. Norhammar A, Bodegard J, Thuresson M, et al. Heart Failure and Health Care Costs: A Full-population Observational Study. Poster presented at HFA Discoveries congress, June 2020. HFA Discoveries Congress. Virtual 2020.
23. Rangaswami J, Bhalla V, Blair JEA, et al. Cardiorenal Syndrome: Classification, Pathophysiology, Diagnosis, and Treatment Strategies: A Scientific Statement From the American Heart Association. *Circulation*. 2019;139(16):e840-e878.
24. Upshaw JN, Konstam MA, Klaveren Dv, et al. Multistate model to predict heart failure hospitalizations and all-cause mortality in outpatients with heart failure with reduced ejection fraction: model derivation and external validation. *Circulation: Heart Failure*. 2016;9(8):e003146.
25. Seferović PM, Petrie MC, Filippatos GS, et al. Type 2 diabetes mellitus and heart failure: a position statement from the Heart Failure Association of the European Society of Cardiology. *European journal of heart failure*. 2018;20(5):853-872.
26. Zareini B, Blanche P, D'Souza M, et al. Type 2 Diabetes Mellitus and Impact of Heart Failure on Prognosis Compared to Other Cardiovascular Diseases: A Nationwide Study. *Circ Cardiovasc Qual Outcomes*. 2020;13(7):e006260.
27. Kamalesh M, Cleophas TJ. Heart failure due to systolic dysfunction and mortality in diabetes: pooled analysis of 39,505 subjects. *J Card Fail*. 2009;15(4):305-309.
28. Romero-Gonzalez G, Ravassa S, Gonzalez O, et al. Burden and challenges of heart failure in patients with chronic kidney disease. A call to action. *Nefrologia (Engl Ed)*. 2020;40(3):223-236.
29. Pfeffer MA, Shah AM, Borlaug BA. Heart Failure With Preserved Ejection Fraction In Perspective. *Circ Res*. 2019;124(11):1598-1617.
30. Heidenreich PA, Bozkurt B, Aguilar D, et al. 2022 AHA/ACC/HFSA Guideline for the Management of Heart Failure: Executive Summary: A Report of the American College of Cardiology/American Heart Association Joint Committee on Clinical Practice Guidelines. *Circulation*. 2022;145(18):e876-e894.
31. Bozkurt B, Coats AJ, Tsutsui H, et al. Universal Definition and Classification of Heart Failure: A Report of the Heart Failure Society of America, Heart Failure Association of the European Society of Cardiology, Japanese Heart Failure Society and Writing Committee of the Universal Definition of Heart Failure. *J Card Fail*. 2021.
32. Shah SJ, Borlaug BA, Kitzman DW, et al. Research Priorities for Heart Failure With Preserved Ejection Fraction: National Heart, Lung, and Blood Institute Working Group Summary. *Circulation*. 2020;141(12):1001-1026.
33. Gastelurrutia P, Lupon J, Moliner P, et al. Comorbidities, Fragility, and Quality of Life in Heart Failure Patients With Midrange Ejection Fraction. *Mayo Clin Proc Innov Qual Outcomes*. 2018;2(2):176-185.
34. Streng KW, Nauta JF, Hillege HL, et al. Non-cardiac comorbidities in heart failure with reduced, mid-range and preserved ejection fraction. *Int J Cardiol*. 2018;271:132-139.
35. Tromp J, Tay WT, Ouwkerk W, et al. Multimorbidity in patients with heart failure from 11 Asian regions: A prospective cohort study using the ASIAN-HF registry. *PLoS Med*. 2018;15(3):e1002541.
36. Sepehrvand N, Savu A, Spertus JA, et al. Change of Health-Related Quality of Life Over Time and Its Association With Patient Outcomes in Patients With Heart Failure. *J Am Heart Assoc*. 2020;9(17):e017278.
37. Upadhyia B, Kitzman DW. Heart failure with preserved ejection fraction: New approaches to diagnosis and management. *Clin Cardiol*. 2020;43(2):145-155.
38. Olchanski N, Vest AR, Cohen JT, et al. Two-year outcomes and cost for heart failure patients following discharge from the hospital after an acute heart failure admission. *Int J Cardiol*. 2020;307:109-113.
39. Lam CSP, Wood R, Vaduganathan M, et al. Contemporary economic burden in a real-world heart failure population with Commercial and Medicare supplemental plans. *Clin Cardiol*. 2021;44(5):646-655.
40. Nguyen C, Zhang X, Evers T, et al. Real-World Treatment Patterns, Healthcare Resource Utilization, and Costs for Patients with Newly Diagnosed Systolic versus Diastolic Heart Failure. *Am Health Drug Benefits*. 2020;13(4):166-174.
41. Divino V, Ramasamy A, Anupindi VR, et al. Complication-specific direct medical costs by body mass index for 13 obesity-related complications: a retrospective database study. *J Manag Care Spec Pharm*. 2021;27(2):210-222.

42. Alghamdi A, Algarni E, Balkhi B, et al. Healthcare Expenditures Associated with Heart Failure in Saudi Arabia: A Cost of Illness Study. *Healthcare (Basel)*. 2021;9(8).
43. National Institute for Cardiovascular Outcomes Research (NICOR). About Heart Failure. Available at: <https://www.nicor.org.uk/national-cardiac-audit-programme/about-heart-failure/#:~:text=Heart%20failure%20is%20a%20large,all%20emergency%20admissions%20to%20hospital> [accessed 17 May 2022].
44. Agha M, Agha R. The rising prevalence of obesity: part A: impact on public health. *Int J Surg Oncol (N Y)*. 2017;2(7):e17.
45. Lloyd-Jones DM, Larson MG, Leip EP, et al. Lifetime risk for developing congestive heart failure: the Framingham Heart Study. *Circulation*. 2002;106(24):3068-3072.
46. National Health Service (NHS). The NHS Long Term Plan. Available from: <https://www.longtermplan.nhs.uk/publication/nhs-long-term-plan> [accessed 17 May 2022]. 2019.
47. Triposkiadis F, Giamouzis G, Parissis J, et al. Reframing the association and significance of co-morbidities in heart failure. *Eur J Heart Fail*. 2016;18(7):744-758.
48. Reddy YNV, Rikhi A, Obokata M, et al. Quality of life in heart failure with preserved ejection fraction: importance of obesity, functional capacity, and physical inactivity. *Eur J Heart Fail*. 2020;22(6):1009-1018.
49. Honigberg MC, Lau ES, Jones AD, et al. Sex Differences in Exercise Capacity and Quality of Life in Heart Failure With Preserved Ejection Fraction: A Secondary Analysis of the RELAX and NEAT-HFpEF Trials. *J Card Fail*. 2020;26(3):276-280.
50. Napier R, McNulty SE, Eton DT, et al. Comparing Measures to Assess Health-Related Quality of Life in Heart Failure With Preserved Ejection Fraction. *JACC Heart Fail*. 2018;6(7):552-560.
51. Clark H, Rana R, Gow J, et al. Hospitalisation costs associated with heart failure with preserved ejection fraction (HFpEF): a systematic review. *Heart Fail Rev*. 2022;27(2):559-572.
52. Cowie MR, Anker SD, Cleland JGF, et al. Improving care for patients with acute heart failure: before, during and after hospitalization. *ESC Heart Fail*. 2014;1(2):110-145.
53. Gheorghide M, Vaduganathan M, Fonarow GC, et al. Rehospitalization for heart failure: problems and perspectives. *J Am Coll Cardiol*. 2013;61(4):391-403.
54. National Institute for Health and Care Excellence (NICE). Resource impact report: Chronic heart failure in adults: diagnosis and management [NG106]. Available at: <https://www.nice.org.uk/guidance/ng106/resources/resource-impact-report-pdf-6537494413> [accessed 30 May 2022]. 2018.
55. Cook C, Cole G, Asaria P, et al. The annual global economic burden of heart failure. *Int J Cardiol*. 2014;171(3):368-376.
56. Greene SJ, Fonarow GC, DeVore AD, et al. Titration of Medical Therapy for Heart Failure With Reduced Ejection Fraction. *J Am Coll Cardiol*. 2019;73(19):2365-2383.
57. National Institute for Cardiovascular Outcomes Research (NICOR). National Heart Failure Audit (NHFA): 2022 Summary Report (2020/21 data). Available from: <https://www.nicor.org.uk/wp-content/uploads/2022/06/NHFA-DOC-2022-FINAL.pdf>. [accessed 21 June 2022]. 2022.
58. Harper A, Patel H, Lyon A. Heart failure with preserved ejection fraction. *Clinical Medicine* 2018;18 (Suppl 2):s24-s29.
59. National Institute for Health and Care Excellence (NICE). Chronic heart failure in adults: diagnosis and management [NG106]. Available at: <https://www.nice.org.uk/guidance/ng106> [accessed 20 April 2022]. 2018.
60. National Health Service (NHS). Quality and Outcomes Framework 2020-21: prevalence at regional and national level. Available at: <https://digital.nhs.uk/data-and-information/publications/statistical/quality-and-outcomes-framework-achievement-prevalence-and-exceptions-data/2020-21> [accessed 5 May 2022]. 2021.
61. Office for National Statistics (ONS). Estimates of the population for the UK, England and Wales, Scotland and Northern Ireland [dataset]. Available at: <https://www.ons.gov.uk/peoplepopulationandcommunity/populationandmigration/populationestimates/datasets/populationestimatesforukenglandandwalescotlandandnorthernireland> [accessed 4 May 2022]. 2021.
62. AstraZeneca UK Ltd. Data on File. ID: REF-155912 [UK Clinical Practice Research Datalink (CPRD)]. 2022.
63. Kahn M, Grayson AD, Chaggar PS, et al. Primary care heart failure service identifies a missed cohort of heart failure patients with reduced ejection fraction. *Eur Heart J*. 2022;43(5):405-412.
64. Bottle A, Kim D, Aylin P, et al. Routes to diagnosis of heart failure: observational study using linked data in England. *Heart*. 2018;104(7):600-605.

65. Papadimitriou L, Moore CK, Butler J, et al. The Limitations of Symptom-based Heart Failure Management. *Card Fail Rev.* 2019;5(2):74-77.
66. Raphael C, Briscoe C, Davies J, et al. Limitations of the New York Heart Association functional classification system and self-reported walking distances in chronic heart failure. *Heart.* 2007;93(4):476-482.
67. Green CP, Porter CB, Bresnahan DR, et al. Development and evaluation of the Kansas City Cardiomyopathy Questionnaire: a new health status measure for heart failure. *J Am Coll Cardiol.* 2000;35(5):1245-1255.
68. Kosiborod MN, Jhund PS, Docherty KF, et al. Effects of Dapagliflozin on Symptoms, Function, and Quality of Life in Patients With Heart Failure and Reduced Ejection Fraction: Results From the DAPA-HF Trial. *Circulation.* 2020;141(2):90-99.
69. Spertus JA, Jones PG, Sandhu AT, et al. Interpreting the Kansas City Cardiomyopathy Questionnaire in Clinical Trials and Clinical Care: JACC State-of-the-Art Review. *J Am Coll Cardiol.* 2020;76(20):2379-2390.
70. Food and Drug Administration (FDA). Qualification of the Kansas City Cardiomyopathy Questionnaire Clinical Summary Score and its Component Scores. A Patient-Reported Outcome Instrument for Use in Clinical Investigations in Heart Failure. 2020. Available at: <https://www.fda.gov/media/136862/download> [accessed 12 August 2022].
71. Hayhoe B, Kim D, Aylin PP, et al. Adherence to guidelines in management of symptoms suggestive of heart failure in primary care. *Heart.* 2019;105(9):678-685.
72. Shen L, Jhund PS, Docherty KF, et al. Accelerated and personalized therapy for heart failure with reduced ejection fraction. *Eur Heart J.* 2022;43(27):2573-2587.
73. Forsyth F, Brimicombe J, Cheriyan J, et al. Characteristics of patients with heart failure with preserved ejection fraction in primary care: a cross-sectional analysis. *BJGP Open.* 2021;5(6).
74. Zheng A, Cowan E, Mach L, et al. Characteristics and outcomes of patients with suspected heart failure referred in line with National Institute for Health and Care Excellence guidance. *Heart.* 2020;106(20):1579-1585.
75. Sowden E, Hossain M, Chew-Graham C, et al. Understanding the management of heart failure with preserved ejection fraction: a qualitative multiperspective study. *Br J Gen Pract.* 2020;70(701):e880-e889.
76. Solomon SD, McMurray JJV, Claggett B, et al. Dapagliflozin in Heart Failure with Mildly Reduced or Preserved Ejection Fraction. *N Engl J Med.* 2022.
77. British Heart Foundation. More people are waiting for heart care because of Covid-19. Available from: <https://www.bhf.org.uk/informationsupport/heart-matters-magazine/news/covid-heart-delays#:~:text=How%20big%20is%20the%20backlog,February%202020%2C%20before%20the%20pandemic>. [accessed 29 June 2022]. 2021.
78. AstraZeneca. Data on File. Clinical Study Report. An international, double-blind, randomised, placebo-controlled phase III study to evaluate the effect of dapagliflozin on reducing cardiovascular death or worsening heart failure in patients with heart failure with preserved Ejection Fraction (HFpEF): DELIVER - Dapagliflozin Evaluation to Improve the LIVEs of Patients with PReserved Ejection Fraction Heart Failure . 2022.
79. AstraZeneca UK Ltd. Data on File. ID: REF-161426 [Draft Manuscript. Dapagliflozin in Heart Failure with Improved Ejection Fraction (Vardeny et al. 2022)]. 2022.
80. Solomon SD, Vaduganathan M, Claggett BL, et al. Baseline Characteristics of Patients With HF With Mildly Reduced and Preserved Ejection Fraction: DELIVER Trial. *JACC Heart Fail.* 2022;10(3):184-197.
81. Nassif ME, Windsor SL, Borlaug BA, et al. The SGLT2 inhibitor dapagliflozin in heart failure with preserved ejection fraction: a multicenter randomized trial. *Nat Med.* 2021;27(11):1954-1960.
82. Trippel TD, Van Linthout S, Westermann D, et al. Investigating a biomarker-driven approach to target collagen turnover in diabetic heart failure with preserved ejection fraction patients. Effect of torasemide versus furosemide on serum C-terminal propeptide of procollagen type I (DROP-PIP trial). *Eur J Heart Fail.* 2018;20(3):460-470.
83. Kitada S, Kikuchi S, Tsujino T, et al. The prognostic value of brain natriuretic peptide in patients with heart failure and left ventricular ejection fraction higher than 60%: a sub-analysis of the J-MELODIC study. *ESC heart failure.* 2018;5(1):36-45.
84. ClinicalTrials.gov. Dapagliflozin in PRESERVED Ejection Fraction Heart Failure (PRESERVED-HF) [NCT03030235]. Available from: <https://clinicaltrials.gov/ct2/show/NCT03030235> [accessed 30 June 2022]. 2021.
85. Solomon SD, McMurray JJV, Claggett B, et al. Dapagliflozin in Heart Failure with Mildly Reduced or Preserved Ejection Fraction (Supplementary Appendix). *N Engl J Med.* 2022.

86. Margulies KB. DELIVERing Progress in Heart Failure with Preserved Ejection Fraction. *New England Journal of Medicine*. 2022.
87. Vaduganathan M, Claggett BL, Jhund P, et al. Estimated Event-Free Survival Benefits with Dapagliflozin in HF with Mildly Reduced or Preserved Ejection Fraction. *J Am Coll Cardiol*. 2022.
88. Cunningham JW, Vaduganathan M, Claggett BL, et al. Dapagliflozin in Patients Recently Hospitalized With Heart Failure and Mildly Reduced or Preserved Ejection Fraction. *Journal of the American College of Cardiology*. 2022.
89. Ostrominski JW, Vaduganathan M, Claggett BL, et al. Dapagliflozin and New York Heart Association functional class in heart failure with mildly reduced or preserved ejection fraction: the DELIVER trial. *European Journal of Heart Failure*. n/a(n/a).
90. Lin DY, Wei L-J, Yang I, et al. Semiparametric regression for the mean and rate functions of recurrent events. *Journal of the Royal Statistical Society: Series B (Statistical Methodology)*. 2000;62(4):711-730.
91. Fitchett D, Zinman B, Wanner C, et al. Heart failure outcomes with empagliflozin in patients with type 2 diabetes at high cardiovascular risk: results of the EMPA-REG OUTCOME(R) trial. *Eur Heart J*. 2016;37(19):1526-1534.
92. Radholm K, Figtree G, Perkovic V, et al. Canagliflozin and Heart Failure in Type 2 Diabetes Mellitus: Results From the CANVAS Program. *Circulation*. 2018;138(5):458-468.
93. AstraZeneca UK Ltd. Data on File. ID: REF-161435 [The effects of dapagliflozin on symptoms, function and quality of life in patients with heart failure and mildly reduced or preserved ejection fraction: results from the DELIVER Trial]. 2022.
94. Jhund PS, Kondo T, Butt JH, et al. Dapagliflozin across the range of ejection fraction in patients with heart failure: a patient-level, pooled meta-analysis of DAPA-HF and DELIVER. *Nat Med*. 2022.
95. Anker SD, Butler J, Filippatos G, et al. Empagliflozin in Heart Failure with a Preserved Ejection Fraction. *N Engl J Med*. 2021;385(16):1451-1461.
96. Vaduganathan M, Docherty KF, Claggett BL, et al. SGLT-2 inhibitors in patients with heart failure: a comprehensive meta-analysis of five randomised controlled trials. *Lancet*. 2022;400(10354):757-767.
97. McMurray JJV, Solomon SD, Inzucchi SE, et al. Dapagliflozin in Patients with Heart Failure and Reduced Ejection Fraction. *N Engl J Med*. 2019;381(21):1995-2008.
98. Heerspink HJL, Stefánsson BV, Correa-Rotter R, et al. Dapagliflozin in Patients with Chronic Kidney Disease. *New England Journal of Medicine*. 2020b;383(15):1436-1446.
99. NHS England. NHS publishes electives recovery plan to boost capacity and give power to patients. Available at: <https://www.england.nhs.uk/2022/02/nhs-publishes-electives-recovery-plan-to-boost-capacity-and-give-power-to-patients/> [accessed 05 August 2022]. 2022.
100. Tsaban G, Alnsasra H, Abu-Dogosh A, et al. Sacubitril/valsartan versus spironolactone in heart failure with preserved ejection fraction; a cost per outcome analysis. *Circulation Conference: American Hearts Association's*. 2021;144(SUPPL 1).
101. National Institute for Health and Care Excellence (NICE). Sacubitril valsartan for treating symptomatic chronic heart failure with reduced ejection fraction [TA388]. Available at: <https://www.nice.org.uk/guidance/ta388> [accessed 05 July 2022].
102. van Hout B, Janssen MF, Feng YS, et al. Interim scoring for the EQ-5D-5L: mapping the EQ-5D-5L to EQ-5D-3L value sets. *Value Health*. 2012;15(5):708-715.
103. Hernández-Alava M, Pudney S. Econometric modelling of multiple self-reports of health states: The switch from EQ-5D-3L to EQ-5D-5L in evaluating drug therapies for rheumatoid arthritis. *J Health Econ*. 2017;55:139-152.
104. Hernández Alava M, Pudney, S. and Wailoo, A., . Estimating the relationship between EQ-5D-5L and EQ-5D-3L: results from an English population study. Policy Research Unit in Economic Evaluation of Health and Care Interventions. Universities of Sheffield and York. Report 063. 2020.
105. National Institute for Health and Care Excellence (NICE). NICE health technology evaluations: the manual. Process and methods [PMG36]. Available at: <https://www.nice.org.uk/process/pmg36/> [accessed 08 September 2022]. 2022.
106. Office for National Statistics (ONS). UK National Life Tables for England and Wales 2017-2019. Available at <https://www.ons.gov.uk/peoplepopulationandcommunity/birthsdeathsandmarriages/lifeexpectancies/bulletins/nationallifetablesunitedkingdom/2017to2019> [accessed 12 August 2022].
107. National Health Service (NHS). National Cost Collection for the NHS. Available from: <https://www.england.nhs.uk/national-cost-collection/> [accessed 29/03/2022]. 2020.

108. Personal Social Services Research Unit. Unit Costs of Health and Social Care 2021. Available at: <https://kar.kent.ac.uk/92342/19/Unit%20Costs%20Report%202021%20-%20Final%20version%20for%20publication.pdf> [accessed 14 July 2022] 2020.
109. Department of Health and Social Care. Drugs and pharmaceutical electronic market information tool (eMIT). Available at: <https://www.gov.uk/government/publications/drugs-and-pharmaceutical-electronic-market-information-emit>, [Last accessed 13 September 2022]. 2018.
110. Electronic Medicines Compendium (EMC). Furosemide 40mg Tablets. Summary of Product Characteristics (SmPC). Available at: <https://www.medicines.org.uk/emc/product/6012/smpc> [accessed 12 August 2022].
111. Electronic Medicines Compendium (EMC). Bumetanide 1 mg Tablets. Summary of Product Characteristics (SmPC). Available at: <https://www.medicines.org.uk/emc/product/2542/smpc> [accessed 12 August 2022].
112. National Institute of Health and Care Excellence (NICE). Empagliflozin for treating chronic heart failure with reduced ejection fraction (TA773). Available at: <https://www.nice.org.uk/guidance/ta773> [accessed 28 June 2022].
113. Bagust A, Beale S. Survival analysis and extrapolation modeling of time-to-event clinical trial data for economic evaluation: an alternative approach. *Medical Decision Making*. 2014;34(3):343-351.
114. Latimer N. NICE DSU Technical Support Document 14: Undertaking survival analysis for economic evaluations alongside clinical trials - extrapolation with patient-level data. Available at: <http://www.nicedsu.org.uk/> [accessed 22 August 2022]. 2011. .
115. Rutherford MJ, Lambert PC, Sweeting MJ, et al. NICE DSU Technical Support Document 21. Flexible Methods for Survival Analysis. 2020. Available at: <http://www.nicedsu.org.uk/> [Accessed 22/08/2022].
116. Jones NR, Roalfe AK, Adoki I, et al. Survival of patients with chronic heart failure in the community: a systematic review and meta-analysis. *Eur J Heart Fail*. 2019;21(11):1306-1325.
117. Shahim A, Hourqueig M, Donal E, et al. Predictors of long-term outcome in heart failure with preserved ejection fraction: a follow-up from the KaRen study. *ESC Heart Fail*. 2021;8(5):4243-4254.
118. World Health Organisation. Global health estimates: Leading causes of death. Available at: <https://www.who.int/data/gho/data/themes/mortality-and-global-health-estimates/ghe-leading-causes-of-death> [accessed 16 August 2021].
119. Heyward J, Mansour O, Olson L, et al. Association between sodium-glucose cotransporter 2 (SGLT2) inhibitors and lower extremity amputation: A systematic review and meta-analysis. *PLoS One*. 2020;15(6):e0234065.
120. AstraZeneca. Data on File. Clinical Study Report. A study to evaluate the effect of dapagliflozin on renal outcomes and cardiovascular mortality in patients with chronic kidney disease (DAPA-CKD). 2020.
121. Beaudet A, Clegg J, Thuresson PO, et al. Review of utility values for economic modeling in type 2 diabetes. *Value Health*. 2014;17(4):462-470.
122. McEwan P, Darlington O, McMurray JJV, et al. Cost-effectiveness of dapagliflozin as a treatment for heart failure with reduced ejection fraction: a multinational health-economic analysis of DAPA-HF. *Eur J Heart Fail*. 2020;22(11):2147-2156.
123. Barry HCE, Mark H. ; Hickner, John. Evaluation of suspected urinary tract infection in ambulatory women : A cost-utility analysis of office-based strategies. *Journal of Family Practice*. 1997;44(1):49-60.
124. Alva ML, Gray A, Mihaylova B, et al. The impact of diabetes-related complications on healthcare costs: new results from the UKPDS (UKPDS 84). *Diabetic Medicine*. 2015;32(4):459-466.
125. Georghiou and Bardsley (2014). Nuffield Trust. Exploring the cost of care at the end of life. Available at: <https://www.nuffieldtrust.org.uk/research/exploring-the-cost-of-care-at-the-end-of-life> [accessed 25 August 2022].
126. McMurray JJV, Trueman D, Hancock E, et al. Cost-effectiveness of sacubitril/valsartan in the treatment of heart failure with reduced ejection fraction. *Heart*. 2018;104(12):1006-1013.
127. Schneider P et al. Quality-adjusted life expectancy norms for the English population. QALY Shortfall Calculator. Available at: <https://github.com/bitowaqr/shortfall> [accessed 12 July 2022]. 2022.
128. Hernández Alava M et al. NICE DSU. Estimating EQ-5D by age and sex for the UK. Available at: <https://nicedsu.sites.sheffield.ac.uk/methods-development/estimating-eq-5d-by-age-and-sex-for-the-uk>. [accessed 10 May 2022]. 2022.
129. Boman K, Lindmark K, Stålhammar J, et al. Healthcare resource utilisation and costs associated with a heart failure diagnosis: a retrospective, population-based cohort study in Sweden. *BMJ Open*. 2021;11(10):e053806.

130. Eddy DM, Hollingworth W, Caro JJ, et al. Model transparency and validation: a report of the ISPOR-SMDM Modeling Good Research Practices Task Force-7. *Med Decis Making*. 2012;32(5):733-743.
131. Caro JJ, Briggs AH, Siebert U, et al. Modeling good research practices--overview: a report of the ISPOR-SMDM Modeling Good Research Practices Task Force--1. *Value Health*. 2012;15(6):796-803.
132. Büyükkaramikli NC, Rutten-van Mölken M, Severens JL, et al. TECH-VER: A Verification Checklist to Reduce Errors in Models and Improve Their Credibility. *Pharmacoeconomics*. 2019;37(11):1391-1408.

B.4. Appendices

Appendix C: Summary of product characteristics (SmPC) and UK public assessment report

Appendix D: Identification, selection and synthesis of clinical evidence

Appendix E: Subgroup analysis

Appendix F: Adverse reactions

Appendix G: Published cost-effectiveness studies

Appendix H: Health-related quality-of-life studies

Appendix I: Cost and healthcare resource identification, measurement and valuation

Appendix J: Clinical outcomes and disaggregated results from the model

Appendix K: Price details of treatments included in the submission

Appendix L: Checklist of confidential information

Appendix M: Additional clinical data – DELIVER trial exploratory endpoints

Appendix N: Additional details regarding the cost-effectiveness model

NATIONAL INSTITUTE FOR HEALTH AND CARE EXCELLENCE

Single Technology Appraisal

Dapagliflozin for treating chronic heart failure with preserved or mildly reduced ejection fraction [ID1648]

Clarification questions

October 2022

File name	Version	Contains confidential information	Date
ID1648 dapagliflozin EAG clarification letter 06102022 IC LW _AZ response 31102022 [ACIC]		Yes	31 October 2022

Section A: Clarification on effectiveness data

Subgroup data – DELIVER trial

A1. Priority question. For the following subgroups it is clinically plausible that results may differ: type 2 diabetes mellitus (T2DM) (yes or no), left ventricular ejection fraction (LVEF) at baseline ($\leq 49\%$, 50-59% and $\geq 60\%$) and previous LVEF $\leq 40\%$ (yes or no).

Therefore, please provide results for the following outcomes for dapagliflozin and placebo arms in each of these subgroups:

- a) Hospitalisation for heart failure;**
- b) Urgent heart failure visit;**
- c) All-cause hospitalisation;**
- d) Adverse events included in Table 43 of the submission;**
- e) Treatment discontinuation;**
- f) Kansas City Cardiomyopathy Questionnaire Total Symptom Score (KCCQ-TSS) scores at baseline and change from baseline scores at 8 months;**
- g) Proportion with 5-point worsening, and 5-, 10- and 15-point improvements on KCCQ-TSS at 8 months.**

For any outcomes where results appear to differ between the subgroup categories (e.g., if there are different results in the group with T2DM compared to those without), please provide a possible clinical rationale for these differences.

Please present results as follows:

- For parts a to c – in line with how they are presented in Table 14.2.2.3 of the clinical study report (CSR), including a breakdown of events and**

number analysed per arm for each subgroup, the hazard ratio with confidence intervals and p-value, and the interaction p-value;

- **For parts d and e – for each treatment arm within each subgroup, the number analysed and the proportion with events;**
- **For part f – baseline values, mean (SD) change from baseline scores at 8 months, number analysed (at baseline and 8 months) and proportion missing (at baseline and 8 months) for each treatment arm within each subgroup; and the relative difference between treatment arms for each subgroup at 8 months, in line with how this is presented for the overall population in Table 14 of the submission (including an assessment of statistical significance);**
- **For part g – in line with how results are presented for these thresholds in the overall population in Figure 12A of the submission (including an assessment of statistical significance).**

Parts a-e

The requested subgroup analyses were not prespecified in the DELIVER trial, nor included in the statistical analysis plan, meaning that limited conclusions can be made from these additional analyses considering multiple testing, small number of events especially for urgent visit and that clinical studies are not initially powered for subgroup analyses even for the primary endpoint. In addition, it is important to contextualise these results with subgroup analyses of the primary endpoint in the DELIVER trial, which demonstrated that the effect of dapagliflozin on the primary outcome was consistent across all the subgroups requested in QA1.¹

Therefore, it is not common practice to explore additional subgroup analyses for additional endpoints following this conclusion. In addition, it is inappropriate to begin exploratory analyses to explore subgroups which have not been discussed or included within the final scope of this appraisal. However, for completeness the requested data are provided below.

Regarding question A1, points a-c, each of the data have been presented below, in Table 1 to Table 6. As expected, and in line with the expectation of assessing the primary endpoint, the treatment effect was consistent across these subgroups for the requested endpoints as supported by the [REDACTED] in the outcomes for any of the requested subgroups as demonstrated by the test for interactions.³

Furthermore, in a recent pooled analysis of the individual patient data from DAPA-HF and DELIVER, in which ejection fraction (EF) was analysed as a continuous variable, there was no interaction between EF and any of the endpoints examined including both total and first hospitalisations for HF (Figure 1).⁴

Figure 1: Effect of dapagliflozin on clinical outcomes across the range of EF

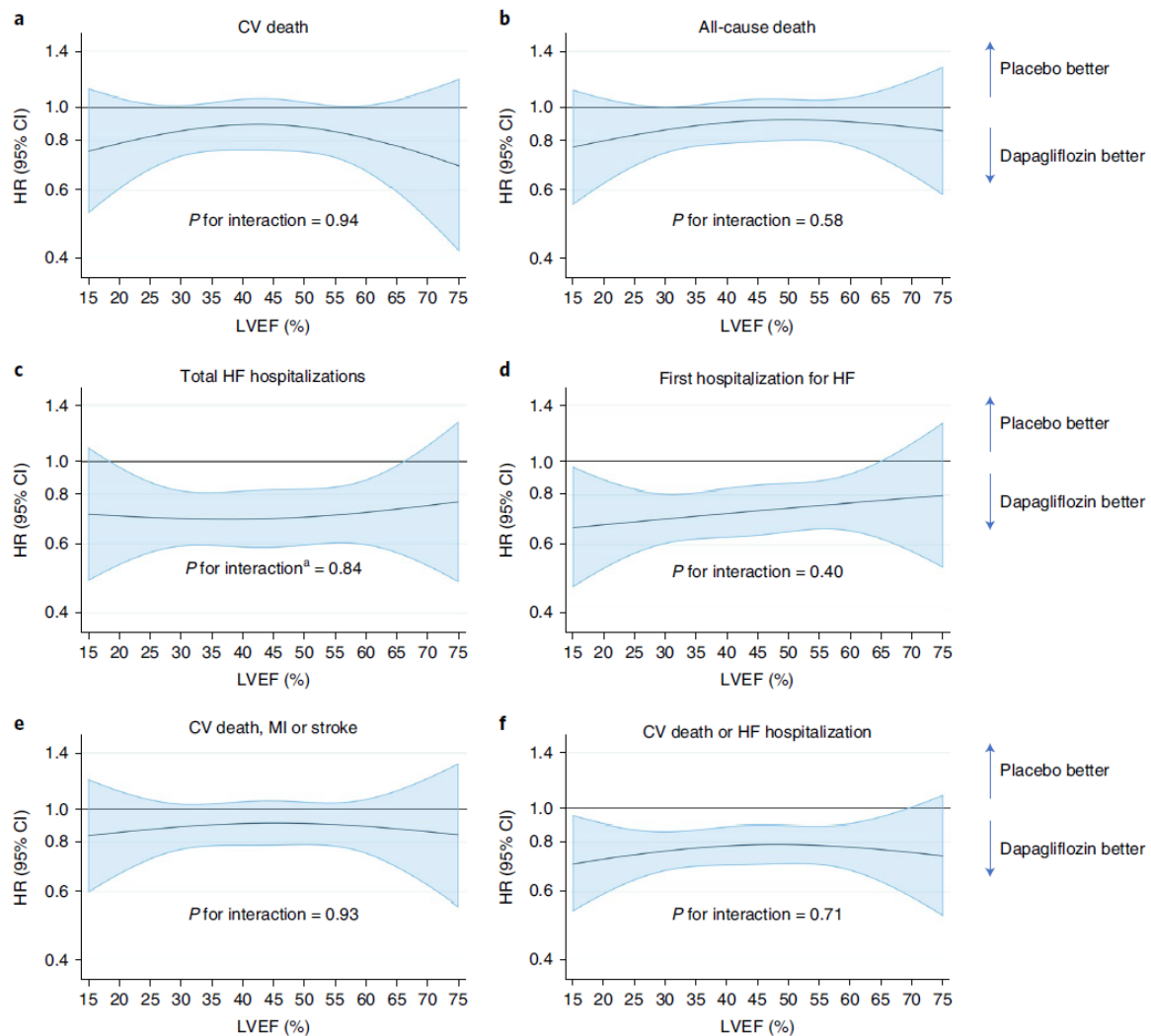

a–f, Effect of dapagliflozin on death from CV causes (a); death from all causes (b); the total number of hospital admissions for HF (c); time to first hospital admission for HF (d); death from CV causes, MI or stroke (e); and death from CV causes or hospital admission for HF (f), according to baseline LVEF. The horizontal blue line shows the continuous HR across the range of LVEF and the shaded area around this line represents the 95% CI from Cox’s model. The overall effect of treatment in the pooled population is shown in each panel as an HR (95% CI) with the two-sided P value from Cox’s model for Wald’s test of interaction between treatment and LVEF. No adjustment for multiple comparisons was made. ^aRestricted cubic spline and interaction P value derived from LWYY model for total HF hospitalisation.

Sources: Jhund *et al.* (2022).⁴

Abbreviations: CI, confidence interval; CV, cardiovascular; EF: ejection fraction; HF, heart failure; LVEF, left ventricular ejection fraction; LWYY, Lin-Wei-Yang-Ying; MI, myocardial infarction.

Regarding question A1, points d-e, similarly to the above, the adverse event profile of dapagliflozin in patients with LVEF >40% is consistent irrespective of other co-morbidities as detailed below in Table 4, Table 5 and Table 6.

Table 1. First hospitalisation for heart failure

Subgroup characteristic category	Dapagliflozin 10 mg (N=3131)			Placebo (N=3132)			Hazard ratio	95% CI	p-value	Interaction p-value
	Number of patients	Patients with event n (%)	Event rate	Number of patients	Patients with event n (%)	Event rate				
T2DM status										
T2DM	■	■	■	■	■	■	■	■	■	■
No T2DM	■	■	■	■	■	■	■	■	■	
LVEF category										
LVEF ≤ 49%	■	■	■	■	■	■	■	■	■	■
LVEF 50-59%	■	■	■	■	■	■	■	■	■	
LVEF ≥ 60%	■	■	■	■	■	■	■	■	■	
History of LVEF ≤40%										
Improved LVEF	■	■	■	■	■	■	■	■	■	■
No prior LVEF ≤40%	■	■	■	■	■	■	■	■	■	

Abbreviations: CI, confidence interval; LVEF, left ventricular ejection fraction; T2DM, type 2 diabetes mellitus.

Source: AstraZeneca UK Ltd. Data on File.³

Table 2. First urgent heart failure visit

Subgroup characteristic category	Dapagliflozin 10 mg (N=3131)			Placebo (N=3132)			Hazard ratio	95% CI	p-value	Interaction p-value
	Number of patients	Patients with event n (%)	Event rate	Number of patients	Patients with event n (%)	Event rate				
T2DM status										
T2DM	■	■	■	■	■	■	■	■	■	■
No T2DM	■	■	■	■	■	■	■	■	■	
LVEF category										
LVEF ≤49%	■	■	■	■	■	■	■	■	■	■
LVEF 50-59%	■	■	■	■	■	■	■	■	■	
LVEF ≥ 60%	■	■	■	■	■	■	■	■	■	
History of LVEF ≤40%										
Improved LVEF	■	■	■	■	■	■	■	■	■	■
No prior LVEF ≤40%	■	■	■	■	■	■	■	■	■	

Abbreviations: CI, confidence interval; LVEF, left ventricular ejection fraction; T2DM, type 2 diabetes mellitus.

Source: AstraZeneca UK Ltd. Data on File.³

Table 3. First all-cause hospitalisation

Subgroup characteristic category	Dapagliflozin 10 mg (N=3131)			Placebo (N=3132)			Hazard ratio	95% CI	p-value	Interaction p-value
	Number of patients	Patients with event n (%)	Event rate	Number of patients	Patients with event n (%)	Event rate				
T2DM status										
T2DM	■	■	■	■	■	■	■	■	■	■
No T2DM	■	■	■	■	■	■	■	■	■	
LVEF category										
LVEF ≤ 49%	■	■	■	■	■	■	■	■	■	■
LVEF 50-59%	■	■	■	■	■	■	■	■	■	
LVEF ≥ 60%	■	■	■	■	■	■	■	■	■	
History of LVEF ≤40%										
Improved LVEF	■	■	■	■	■	■	■	■	■	■
No prior LVEF ≤40%	■	■	■	■	■	■	■	■	■	

Abbreviations: CI, confidence interval; LVEF, left ventricular ejection fraction; T2DM, type 2 diabetes mellitus.

Source: AstraZeneca UK Ltd. Data on File.³

Table 4. Adverse events and discontinuation stratified by T2DM subgroups

	T2DM		No T2DM	
	Dapagliflozin (N=1,399)	Placebo (N=1,402)	Dapagliflozin (N=1,727)	Placebo (N=1,725)
Acute kidney injury	■	■	■	■
Fracture	■	■	■	■
Urinary tract infection	■	■	■	■
Volume depletion	■	■	■	■
Amputation	■	■	■	■
Major hypoglycaemia	■	■	■	■
Diabetic ketoacidosis	■	■	■	■
Genital infection	■	■	■	■
Discontinuation	■	■	■	■

Number of patients analysed (N) corresponds to the safety analysis set.

Abbreviations: T2DM, type 2 diabetes mellitus.

Source: AstraZeneca UK Ltd. Data on File.³

Table 5. Adverse events and discontinuation stratified by categorical LVEF subgroups

	LVEF ≤ 49%		LVEF 50-59%		LVEF ≥ 60%	
	Dapagliflozin 10 mg (N=1,066)	Placebo (N=1,047)	Dapagliflozin 10 mg (N=1,132)	Placebo (N=1,121)	Dapagliflozin 10 mg (N=928)	Placebo (N=959)
Acute kidney injury	■	■	■	■	■	■
Fracture	■	■	■	■	■	■
Urinary tract infection	■	■	■	■	■	■
Volume depletion	■	■	■	■	■	■
Amputation	■	■	■	■	■	■
Major hypoglycaemia	■	■	■	■	■	■
Diabetic ketoacidosis	■	■	■	■	■	■
Genital infection	■	■	■	■	■	■
Discontinuation	■	■	■	■	■	■

Number of patients analysed (N) corresponds to the safety analysis set.

Abbreviations: LVEF, left ventricular ejection fraction.

Source: AstraZeneca UK Ltd. Data on File.³

Table 6. Adverse events and discontinuation stratified by history of LVEF ≤ 40% (Improved LVEF)

	Improved LVEF		No history of LVEF ≤ 40%	
	Dapagliflozin 10 mg (N=572)	Placebo (N=577)	Dapagliflozin 10 mg (N=2,554)	Placebo (N=2,550)
Acute kidney injury	■	■	■	■
Fracture	■	■	■	■
Urinary tract infection	■	■	■	■
Volume depletion	■	■	■	■
Amputation	■	■	■	■
Major hypoglycaemia	■	■	■	■
Diabetic ketoacidosis	■	■	■	■
Genital infection	■	■	■	■
Discontinuation	■	■	■	■

Number of patients analysed (N) corresponds to the safety analysis set.

Abbreviations: LVEF, left ventricular ejection fraction.

Source: AstraZeneca UK Ltd. Data on File.³

Parts f-g

Mean and standard deviation of KCCQ-TSS at baseline and change from baseline at 8 months by treatment group in each subgroup, and analysis of difference between dapagliflozin and placebo in mean change from baseline are presented in the Appendix Table 34, with a p-value for the interaction between the respective subgroup variable and treatment group. The denominator for the proportion of missing data (N#) is the number of patients alive in the study at 8 months. The mean difference is estimated in a model adjusted for baseline TSS and may therefore differ from the difference between the presented raw means of change from baseline by treatment group.

Table 37 in the Appendix presents the proportion of patients with 5 points deterioration and 5, 10 and 15 points improvement in KCCQ-TSS from baseline to 8 months in each subgroup, with an odds ratio for dapagliflozin vs placebo and a p-value for interaction between subgroup variable and treatment group.

Type 2 diabetes mellitus (T2DM) (yes or no)

Patients with T2DM appeared to have a ■ in mean TSS at 8 months compared to patients without T2DM (■, interaction p-value ■), however the mean difference compared to placebo was ■ in both patient groups. In the responder analysis, the proportion of patients with at least 5 points deterioration of TSS from baseline was ■ compared with placebo in both patients with and without T2DM, while in analysis of 5, 10 and 15 points improvement most benefit was observed for patients with T2DM, although the interaction test for difference in treatment effect between subgroups was ■. Given the consistent treatment effect on the primary composite endpoint in patient with and without T2DM, mechanisms of action of dapagliflozin as well as the known caveats about post hoc subgroups analyses there is no plausible rationale for a ■ treatment effect on symptoms in patients without T2DM. However, given the ■ baseline score and ■ proportion overall reaching the improvement thresholds in patients without T2DM, it could be

hypothesized that the observations are a result of [REDACTED]

Left ventricular ejection fraction (LVEF) at baseline ($\leq 49\%$, 50-59% and $\geq 60\%$)

The treatment effects of dapagliflozin were [REDACTED] subgroups of baseline LVEF of ≤ 49 , 50-59 and $\geq 60\%$ (p-value for interaction [REDACTED]). The mean difference was [REDACTED] for LVEF 50-59, however, [REDACTED] LVEF was observed. In responder analysis of deterioration, the [REDACTED] compared to placebo was [REDACTED] LVEF subgroups (interaction p-value [REDACTED]), while observed odds ratios for improvement [REDACTED] in the ≥ 60 group, although [REDACTED] for the 10 points-threshold. Baseline TSS was [REDACTED] the LVEF categories and does not provide a possible explanation such as hypothesized for the non-diabetic subgroup above, and this may be a chance finding.

LVEF $\leq 40\%$ (yes or no)

The [REDACTED] of baseline TSS compared to placebo was [REDACTED] observed in both patients with and without prior LVEF $\leq 40\%$ (interaction p-value [REDACTED]), although the magnitude of the difference was [REDACTED] among those with prior LVEF $\leq 40\%$. In the responder analyses, [REDACTED] was observed in both groups for 5 points deterioration. For the improvement thresholds the odds ratio was [REDACTED] in patients without prior LVEF $\leq 40\%$, [REDACTED] and this data does not provide any evidence of difference in treatment effect of dapagliflozin in patients with and without prior LVEF $\leq 40\%$.

A2. Priority question. For the subgrouping strategy based on previous LVEF $\leq 40\%$ (yes or no), in addition to those outcomes requested above in A1, please provide the results for the following outcomes in each arm, as these do not appear in the CSR:

- a) Heart failure event (hospitalisation for heart failure or urgent heart failure visit);**
- b) Cardiovascular (CV) death;**
- c) All-cause mortality.**

Please provide results in line with how they are presented in Table 14.2.2.3 of the CSR, including a breakdown of events and number analysed per arm for each subgroup, the hazard ratio with confidence intervals and p-value, and the interaction p-value.

For any outcomes where results appear to differ between the subgroup categories (e.g., if there are different results in the group with prior LVEF $\leq 40\%$

compared to those without this), please provide a possible clinical rationale for these differences.

The requested data, previously provided in a draft manuscript by Vardeny *et al.* (2022)⁵ as part of the original submission reference pack, are summarised in Table 7 below.

The results demonstrate that the treatment effect of dapagliflozin versus placebo on HF outcomes was [redacted] in patients with HF and a prior LVEF ≤40% (HF with an improved ejection fraction [HFimpEF]) and patients without prior LVEF ≤40% .⁵ [redacted] was observed between these two groups of patients with respect to HF events (p=[redacted]), CV death (p=[redacted]) or all-cause mortality (p=[redacted]).⁵

As such, there is no rationale for further consideration of subgroups based on presence or absence of a prior ≤40% LVEF.

Table 7: Summary of treatment effect for dapagliflozin versus placebo based on prior LVEF status

Variable	HFimpEF ^a (N=1,151)	LVEF > 40% (N=5,112)
CV mortality		
Events	[redacted]	[redacted]
Events per 100 patient years	[redacted]	[redacted]
Hazard ratio for dapagliflozin versus placebo (95% CI)	[redacted]	[redacted]
P-value for dapagliflozin versus placebo	[redacted]	[redacted]
Subgroup interaction p-value	[redacted]	
HF event		
Events	[redacted]	[redacted]
Events per patient years	[redacted]	[redacted]
Hazard ratio for dapagliflozin versus placebo	[redacted]	[redacted]
P-value for dapagliflozin versus placebo	[redacted]	[redacted]
Subgroup interaction p-value	[redacted]	
All-cause mortality		
Events	[redacted]	[redacted]
Events per patient years	[redacted]	[redacted]
Hazard ratio for dapagliflozin versus placebo	[redacted]	[redacted]
P-value for dapagliflozin versus placebo	[redacted]	[redacted]
Subgroup interaction p-value	[redacted]	

^aPatients who previously had an LVEF ≤40%.

Abbreviations: CI: confidence interval; CV: cardiovascular; HF: heart failure; HFimpEF: heart failure with an improved EF; LVEF: left ventricular ejection fraction.

Source: AstraZeneca UK Ltd. Data on File.⁵

A3. Priority question. The evidence assessment group (EAG) understands that the group with a prior LVEF $\leq 40\%$ have different standard of care (SoC) options as they may continue to be treated as if they had an LVEF $< 40\%$. Please comment on the expected impact of including this group in the results and the rationale for focusing on the intention-to-treat (ITT) population with this group included, particularly given they may already be eligible for dapagliflozin in clinical practice.

Although the treatment history of patients with a prior LVEF $\leq 40\%$ (HFimpEF) may differ from those without, the current treatment options for patients with HF and an LVEF $> 40\%$ are the same, regardless of prior LVEF, therefore the SoC for each group is equivalent. Patients with HFimpEF would formerly have been eligible for dapagliflozin, but since they now have an LVEF $> 40\%$, dapagliflozin is not currently a recommended treatment for them according to NICE guidance.⁶

Since this population was previously unstudied, it was necessary to include this group within the DELIVER trial to understand whether there were any differences in the treatment effects of dapagliflozin experienced by this patient population. Furthermore, it is important that this patient population is considered for treatment with dapagliflozin, given that there is a risk that patients who previously had HF and a prior LVEF $\leq 40\%$ but subsequently experienced an improvement in EF, may then discontinue their treatment for HF and an LVEF $< 40\%$.

However, as the treatment effect of dapagliflozin versus placebo was [REDACTED] in this subgroup of patients⁵ (as detailed in response to Question A2), there is no rationale for further consideration of subgroups based on prior LVEF percentage.

A4. Priority question. For the following subgroup strategies, results in the submission and/or CSR suggest larger differences for some outcomes. Please provide a possible rationale for these differences and comment on whether they are a concern:

- a) **Subgroups based on median systolic blood pressure - larger differences (relative to other subgroup strategies) between the two groups for the composite outcome [REDACTED];**

The DELIVER investigators have published a paper specifically examining the interplay between systolic blood pressure (SBP) and treatment effects of dapagliflozin.⁷ This analysis demonstrated that baseline SBP does not modify the relationship between dapagliflozin and the primary outcome, cardiovascular death, HF hospitalisation, and all-cause death (interaction p-value=0.15, 0.73, 0.10 and 0.16, respectively; Figure 2).⁷

Figure 2: Treatment Effect of Dapagliflozin on Efficacy Outcomes across Baseline Systolic Blood Pressure

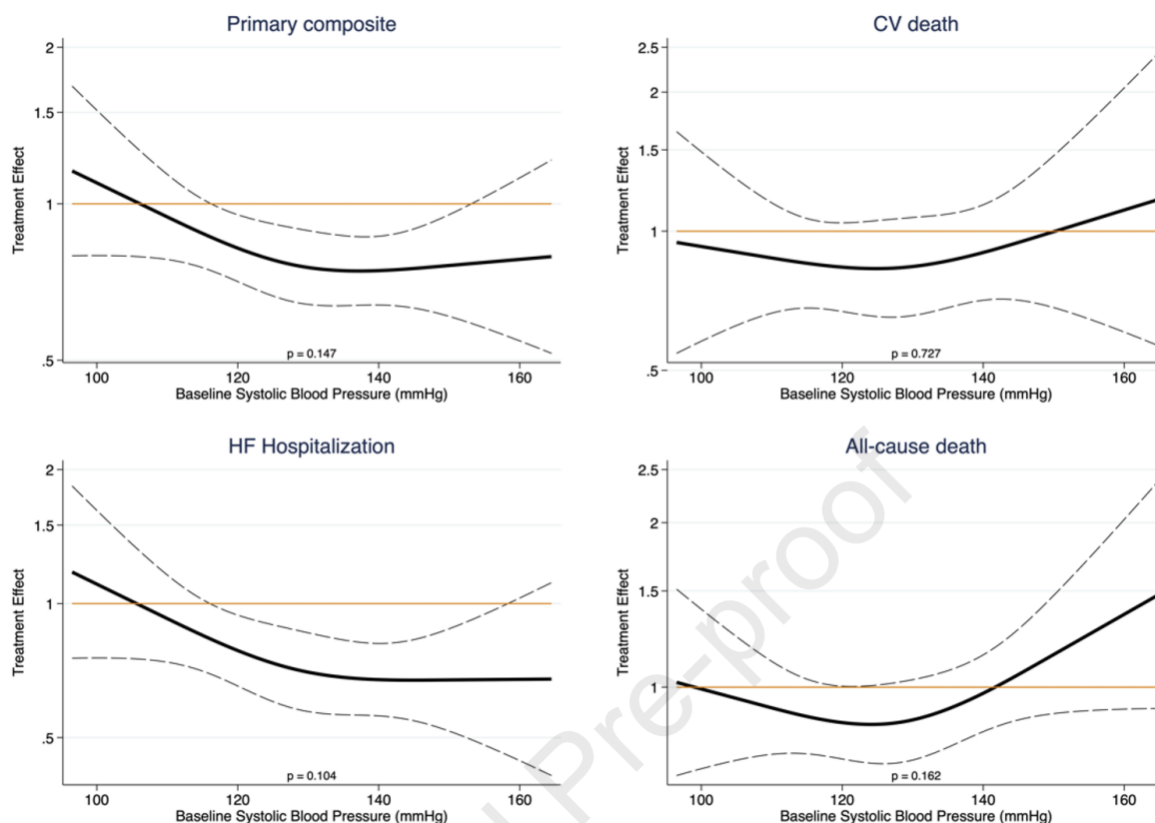

The hazard ratios of dapagliflozin versus placebo on several outcomes are shown as continuous splines by baseline systolic blood pressure. Interrupted lines represent 95% confidence interval. P-value shown for treatment continuous systolic blood pressure interaction term.

Abbreviations: CV, cardiovascular; HF, heart failure.

Source: Selvaraj *et al.* (2022).⁷

b) Subgroups based on median body mass index (BMI) - larger differences (relative to other subgroup strategies) between the two groups for the composite outcome [REDACTED];

As presented in the previously provided DELIVER CSR, there was [REDACTED] observed in the pre-planned subgroup analyses by BMI <30 and ≥30 (interaction p-value=[REDACTED]). This demonstrates a [REDACTED] of BMI and is further supported by the analyses by Adamson *et al.* examining the effects of dapagliflozin according to BMI among patients in the DELIVER trial in a paper entitled “Dapagliflozin for heart failure according to body mass index: the DELIVER trial”.⁸

Patients were classified according to WHO criteria and were:

- Normal weight: 1343 (21.5%);
- Overweight: 2073 (33.1%);
- Class I obesity: 1574 (25.2%);
- Class II obesity: 798 (12.8%);

- Class III obesity: 415 (6.6%).

Compared to placebo, dapagliflozin reduced the risk of the primary outcome to a similar extent across these categories: HR: 0.89 (95% CI: 0.69, 1.15), HR: 0.87 (95% CI: 0.70, 1.08), HR: 0.74 (95% CI: 0.58, 0.93), HR: 0.78 (0.57, 1.08), and HR: 0.72 (95% CI: 0.47, 1.08), respectively (p-interaction=0.82). Therefore, dapagliflozin reduced the risk of the primary outcome to a similar extent across BMI categories and is further supported by analysis of treatment effect by continuous BMI in Figure 3 (p-value for interaction=0.68).

The placebo-corrected change in KCCQ total symptom score with dapagliflozin at 8 months across each of these categories was: 0.9 (-1.1, 2.8), 2.5 (0.8, 4.1), 1.9 (-0.1, 3.8), 2.7 (-0.5, 5.8), and 8.6 (4.0, 13.2) points, respectively (p-interaction=0.03). This means that patients with obesity experienced greater symptom improvement with dapagliflozin compared with patients who were not obese. In addition, patients in the treatment group also had the additional benefit of modest weight loss. The placebo-corrected change in weight at 12 months across these categories was: -0.88 (-1.28, -0.47), -0.65 (-1.04, -0.26), -1.42 (-1.89, -0.94), -1.17 (-1.94, -0.40), and -2.50 (-4.4, -0.64) kg (p-interaction=0.002).⁸

Figure 3: Structured graphical abstract from Adamson et al. 2022

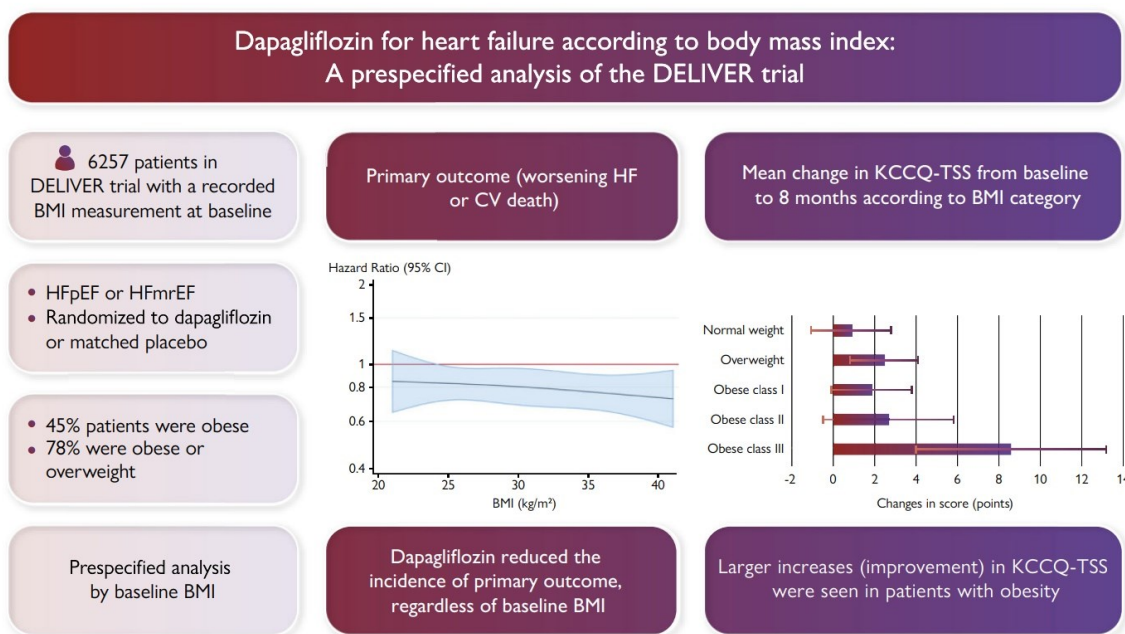

Source: Adamson *et al.* (2022).⁸

Abbreviations: BMI, body mass index; CV, cardiovascular; DELIVER, Dapagliflozin Evaluation to Improve the LIVES of Patients With Preserved Ejection Fraction Heart Failure; HFmrEF, heart failure with mildly reduced ejection fraction; HFpEF, heart failure with preserved ejection fraction; KCCQ-TSS, Kansas City Cardiomyopathy Questionnaire Total Symptom Score.

c) Europe + Saudi Arabia subgroup - similar to the Asia subgroup, for [REDACTED], there is [REDACTED] in this group compared to North/South America subgroups.

AstraZeneca are not aware of [REDACTED] based on the geographical locations upon which patients are treated. It is not uncommon to see some variations in the hazard ratios in the data, particularly for endpoints that have a relatively small number of events

such as CV death. The test for interaction demonstrates that this is a [REDACTED] effect with the p-value reported of [REDACTED]. DELIVER was not powered for subgroup analysis for geographical locations for either the primary endpoint or its components, meaning that limited conclusions can be made from these additional analyses considering multiple testing, small number of events, and that clinical studies are not initially powered for subgroup analyses even for the primary endpoint.⁹

A5. Please provide baseline characteristics separately for the subgroups mentioned in question A1 (T2DM, yes or no; LVEF at baseline, $\leq 49\%$, 50-59% and $\geq 60\%$; and previous LVEF $\leq 40\%$, yes or no).

Baseline characteristics are provided below using the EAG-supplied template separately for the dapagliflozin and placebo treatment arms, stratified by T2DM status (Table 8), LVEF categorisation as $\leq 49\%$, 50-59% or $\geq 60\%$ (Table 9), and history of LVEF $\leq 40\%$ (Table 10).

Table 8. Baseline characteristics by T2DM status and treatment arm

Baseline characteristics	T2DM (N = 2,806)		No T2DM (N = 3,457)	
	Dapagliflozin (n = 1,401)	Placebo (n = 1,405)	Dapagliflozin (n = 1,730)	Placebo (n = 1,727)
Demographics				
Mean age (years)	■	■	■	■
Female sex, n (%)	■	■	■	■
Race, n (%)				
White	■	■	■	■
Black	■	■	■	■
Asian	■	■	■	■
American Indian or Alaska Native	■	■	■	■
Other	■	■	■	■
Time from diagnosis and HHF				
Time from diagnosis of HF to enrolment, n (%)				
0-3 months	■	■	■	■
>3-6 months	■	■	■	■
>6-12 months	■	■	■	■
>1-2 years	■	■	■	■
>2-5 years	■	■	■	■
>5 years	■	■	■	■
Prior HF hospitalisation, n (%)	■	■	■	■
HF characteristics				
NYHA class, n (%)				
I	■	■	■	■
II	■	■	■	■
III	■	■	■	■
IV	■	■	■	■
Median LVEF (%), (Q1, Q3)	■	■	■	■
LVEF group, n (%)				
≤40	■	■	■	■
≥41-49	■	■	■	■
≥50-59	■	■	■	■
≥60	■	■	■	■
Patients with prior LVEF ≤40%, n (%)	■	■	■	■
LV hypertrophy, n (%)	■	■	■	■
LA enlargement, n (%)	■	■	■	■
AF or flutter at enrolment ECG, n (%)	■	■	■	■
Disease-related medical history, n (%)				
T2DM	■	■	■	■

Baseline characteristics	T2DM (N = 2,806)		No T2DM (N = 3,457)	
	Dapagliflozin (n = 1,401)	Placebo (n = 1,405)	Dapagliflozin (n = 1,730)	Placebo (n = 1,727)
Valvular heart disease	██████	██████	██████	██████
Ventricular arrhythmia	██████	██████	██████	██████
Hypertension	██████	██████	██████	██████
Myocardial infarction	██████	██████	██████	██████
Stable or unstable angina pectoris	██████	██████	██████	██████
Stroke	██████	██████	██████	██████
Transient ischaemic attack	██████	██████	██████	██████
Coronary artery stenosis	██████	██████	██████	██████
Dyslipidaemia	██████	██████	██████	██████
Chronic obstructive pulmonary disease	██████	██████	██████	██████
Gout	██████	██████	██████	██████
Laboratory measures				
Mean eGFR (ml/min/1.73m ²) (min, max)	██████	██████	██████	██████
HF and CV medication at randomisation, n (%)				
ACEi	██████	██████	██████	██████
ARB	██████	██████	██████	██████
ARNI	██████	██████	██████	██████
Beta-blocker	██████	██████	██████	██████
Calcium channel blocker	██████	██████	██████	██████
MRA	██████	██████	██████	██████
Loop diuretics	██████	██████	██████	██████
Other (non-loop non-MRA) diuretics	██████	██████	██████	██████
Digitalis glycosides	██████	██████	██████	██████
Vasodilators	██████	██████	██████	██████
Lipid-lowering drugs	██████	██████	██████	██████
Statins	██████	██████	██████	██████
Antithrombotic agents	██████	██████	██████	██████

Source: AstraZeneca UK Ltd. Data on File.³

Abbreviations: ACEi: angiotensin converting enzyme inhibitor; ARB: angiotensin-receptor blocker; ARNI: angiotensin receptor neprilysin inhibitor; AF: atrial fibrillation; CV: cardiovascular; ECG: echocardiogram; eGFR: estimated glomerular filtration rate; HF: heart failure; HHF: hospitalisation for heart failure; LA: left atrial; LV left ventricular; LVEF: left ventricular ejection fraction; MRA: Mineralocorticoid-receptor antagonist; NYHA: New York Heart Association; T2DM: type 2 diabetes mellitus.

Table 9. Baseline characteristics by LVEF group and treatment arm

Baseline characteristics	LVEF ≤49% (N = 2,116)		LVEF 50-59% (N = 2,256)		LVEF ≥60% (N = 1,891)	
	Dapagliflozin (n = 1,067)	Placebo (n = 1,049)	Dapagliflozin (n = 1,133)	Placebo (n = 1,123)	Dapagliflozin (n = 931)	Placebo (n = 960)
Demographics						
Mean age (years)	■	■	■	■	■	■
Female sex, n (%)	■	■	■	■	■	■
Race, n (%)						
White	■	■	■	■	■	■
Black	■	■	■	■	■	■
Asian	■	■	■	■	■	■
American Indian or Alaska Native	■	■	■	■	■	■
Other	■	■	■	■	■	■
Time from diagnosis and HHF						
Time from diagnosis of HF to enrolment, n (%)						
0-3 months	■	■	■	■	■	■
>3-6 months	■	■	■	■	■	■
>6-12 months	■	■	■	■	■	■
>1-2 years	■	■	■	■	■	■
>2-5 years	■	■	■	■	■	■
>5 years	■	■	■	■	■	■
Prior HF hospitalisation, n (%)	■	■	■	■	■	■
HF characteristics						
NYHA class, n (%)						
I	■	■	■	■	■	■
II	■	■	■	■	■	■
III	■	■	■	■	■	■
IV	■	■	■	■	■	■

Baseline characteristics	LVEF ≤49% (N = 2,116)		LVEF 50-59% (N = 2,256)		LVEF ≥60% (N = 1,891)	
	Dapagliflozin (n = 1,067)	Placebo (n = 1,049)	Dapagliflozin (n = 1,133)	Placebo (n = 1,123)	Dapagliflozin (n = 931)	Placebo (n = 960)
Median LVEF (%), (Q1, Q3)	██████████	██████████	██████████	██████████	██████████	██████████
LVEF group, n (%)						
≤40	██████	██████	██████	██████	██████	██████
≥41-49	██████████	██████████	██████	██████	██████	██████
≥50-59	██████	██████	██████████	██████████	██████	██████
≥60	██████	██████	██████	██████	██████████	██████████
Patients with prior LVEF ≤40%, n (%)	██████████	██████████	██████████	██████████	██████████	██████████
LV hypertrophy, n (%)	██████████	██████████	██████████	██████████	██████████	██████████
LA enlargement, n (%)	██████████	██████████	██████████	██████████	██████████	██████████
AF or flutter at enrolment ECG, n (%)	██████████	██████████	██████████	██████████	██████████	██████████
Disease-related medical history, n (%)						
T2DM	██████████	██████████	██████████	██████████	██████████	██████████
Valvular heart disease	██████████	██████████	██████████	██████████	██████████	██████████
Ventricular arrhythmia	██████████	██████████	██████	██████	██████	██████
Hypertension	██████████	██████████	██████████	██████████	██████████	██████████
Myocardial infarction	██████████	██████████	██████████	██████████	██████████	██████████
Stable or unstable angina pectoris	██████████	██████████	██████████	██████████	██████████	██████████
Stroke	██████████	██████████	██████████	██████████	██████████	██████████
Transient ischaemic attack	██████████	██████████	██████████	██████████	██████████	██████████
Coronary artery stenosis	██████████	██████████	██████████	██████████	██████████	██████████
Dyslipidaemia	██████████	██████████	██████████	██████████	██████████	██████████
Chronic obstructive pulmonary disease	██████████	██████████	██████████	██████████	██████████	██████████
Gout	██████████	██████████	██████████	██████████	██████████	██████████
Laboratory measures						
Mean eGFR (ml/min/1.73m ²) (min, max)	██████████	██████████	██████████	██████████	██████████	██████████

Baseline characteristics	LVEF ≤49% (N = 2,116)		LVEF 50-59% (N = 2,256)		LVEF ≥60% (N = 1,891)	
	Dapagliflozin (n = 1,067)	Placebo (n = 1,049)	Dapagliflozin (n = 1,133)	Placebo (n = 1,123)	Dapagliflozin (n = 931)	Placebo (n = 960)
HF and CV medication at randomisation, n (%)						
ACEi	██████	██████	██████	██████	██████	██████
ARB	██████	██████	██████	██████	██████	██████
ARNI	██████	██████	██████	██████	██████	██████
Beta-blocker	██████	██████	██████	██████	██████	██████
Calcium channel blocker	██████	██████	██████	██████	██████	██████
MRA	██████	██████	██████	██████	██████	██████
Loop diuretics	██████	██████	██████	██████	██████	██████
Other (non-loop non-MRA) diuretics	██████	██████	██████	██████	██████	██████
Digitalis glycosides	██████	██████	██████	██████	██████	██████
Vasodilators	██████	██████	██████	██████	██████	██████
Lipid-lowering drugs	██████	██████	██████	██████	██████	██████
Statins	██████	██████	██████	██████	██████	██████
Antithrombotic agents	██████	██████	██████	██████	██████	██████

Source: AstraZeneca UK Ltd. Data on File.³

Abbreviations: ACEi: angiotensin converting enzyme inhibitor; ARB: angiotensin-receptor blocker; ARNI: angiotensin receptor neprilysin inhibitor; AF: atrial fibrillation; CV: cardiovascular; ECG: echocardiogram; eGFR: estimated glomerular filtration rate; HF: heart failure; HHF: hospitalisation for heart failure; LA: left atrial; LV left ventricular; LVEF: left ventricular ejection fraction; MRA: Mineralocorticoid-receptor antagonist; NYHA: New York Heart Association; T2DM: type 2 diabetes mellitus.

Table 10. Baseline characteristics by history of prior LVEF ≤40% and treatment arm

Baseline characteristics	Prior LVEF ≤40% (N = 1,151)		No prior LVEF ≤40% (N = 5,112)	
	Dapagliflozin (n = 572)	Placebo (n = 579)	Dapagliflozin (n = 2,559)	Placebo (n = 2,553)
Demographics				
Mean age (years)	■	■	■	■
Female sex, n (%)	■	■	■	■
Race, n (%)				
White	■	■	■	■
Black	■	■	■	■
Asian	■	■	■	■
American Indian or Alaska Native	■	■	■	■
Other	■	■	■	■
Time from diagnosis and HHF				
Time from diagnosis of HF to enrolment, n (%)				
0-3 months	■	■	■	■
>3-6 months	■	■	■	■
>6-12 months	■	■	■	■
>1-2 years	■	■	■	■
>2-5 years	■	■	■	■
>5 years	■	■	■	■
Prior HF hospitalisation, n (%)	■	■	■	■
HF characteristics				
NYHA class, n (%)				
I	■	■	■	■
II	■	■	■	■
III	■	■	■	■
IV	■	■	■	■
Median LVEF (%), (Q1, Q3)	■	■	■	■
LVEF group, n (%)				
≤40	■	■	■	■
≥41-49	■	■	■	■
≥50-59	■	■	■	■
≥60	■	■	■	■
Patients with prior LVEF ≤40%, n (%)	■	■	■	■
LV hypertrophy, n (%)	■	■	■	■
LA enlargement, n (%)	■	■	■	■
AF or flutter at enrolment ECG, n (%)	■	■	■	■
Disease-related medical history, n (%)				
T2DM	■	■	■	■

Baseline characteristics	Prior LVEF ≤40% (N = 1,151)		No prior LVEF ≤40% (N = 5,112)	
	Dapagliflozin (n = 572)	Placebo (n = 579)	Dapagliflozin (n = 2,559)	Placebo (n = 2,553)
Valvular heart disease	██████	██████	██████	██████
Ventricular arrhythmia	██████	██████	██████	██████
Hypertension	██████	██████	██████	██████
Myocardial infarction	██████	██████	██████	██████
Stable or unstable angina pectoris	██████	██████	██████	██████
Stroke	██████	██████	██████	██████
Transient ischaemic attack	██████	██████	██████	██████
Coronary artery stenosis	██████	██████	██████	██████
Dyslipidaemia	██████	██████	██████	██████
Chronic obstructive pulmonary disease	██████	██████	██████	██████
Gout	██████	██████	██████	██████
Laboratory measures				
Mean eGFR (ml/min/1.73m ²) (min, max)	██████	██████	██████	██████
HF and CV medication at randomisation, n (%)				
ACEi	██████	██████	██████	██████
ARB	██████	██████	██████	██████
ARNI	██████	██████	██████	██████
Beta-blocker	██████	██████	██████	██████
Calcium channel blocker	██████	██████	██████	██████
MRA	██████	██████	██████	██████
Loop diuretics	██████	██████	██████	██████
Other (non-loop non-MRA) diuretics	██████	██████	██████	██████
Digitalis glycosides	██████	██████	██████	██████
Vasodilators	██████	██████	██████	██████
Lipid-lowering drugs	██████	██████	██████	██████
Statins	██████	██████	██████	██████
Antithrombotic agents	██████	██████	██████	██████

Source: AstraZeneca UK Ltd. Data on File.³

Abbreviations: ACEi: angiotensin converting enzyme inhibitor; ARB: angiotensin-receptor blocker; ARNI: angiotensin receptor neprilysin inhibitor; AF: atrial fibrillation; CV: cardiovascular; ECG: echocardiogram; eGFR: estimated glomerular filtration rate; HF: heart failure; HHF: hospitalisation for heart failure; LA: left atrial; LV left ventricular; LVEF: left ventricular ejection fraction; MRA: Mineralocorticoid-receptor antagonist; NYHA: New York Heart Association; T2DM: type 2 diabetes mellitus.

KCCQ-TSS

A6. Priority question. In relation to the assessment of KCCQ-TSS scores, please clarify the following:

- a) Why, while the median duration of the trial was █ months, the latest time-point KCCQ-TSS data is reported at is 8 months;**

Similar to several other outcome trials in HF with long term follow-up, the DELIVER protocol specified an objective for evaluation of change from baseline in KCCQ at, or prior to, 12 months from randomisation, and for DELIVER at 8 months¹¹ (DAPA-HF: 8 months.¹² EMPEROR-Reduced and EMPEROR-Preserved: 12 months^{13, 14}).

The 8-month time point was selected based on precedent from PARADIGM-HF¹⁵ and PARAGON-HF¹⁶ in trade-off between accumulating treatment effect and longer-term evaluation of KCCQ versus limiting the impact of competing risk of death and other serious events which make data interpretation difficult. The data collection was targeted to evaluate the study objectives with KCCQ collected up until 8 months (and at end of study and premature treatment discontinuation visits occurring at varying time from randomisation). This is similar to other trials, e.g., EMPEROR-Reduced¹⁴ and EMPEROR-Preserved¹³ where KCCQ was collected at scheduled visits up until 12 months in line with the study KCCQ objective.

- b) Why it was deemed necessary to focus on the analysis where only patients that had their 8-month follow-up █ for the KCCQ-TSS scores but not for other outcomes (e.g. the primary outcome or its components, or the EQ-5D-5L reported in the CSR);**

The decision to limit the confirmatory analysis of change from baseline KCCQ-TSS to patients with their 8 months visit planned or performed prior to the COVID-19 outbreak was added to the Statistical Analysis Plan (SAP) in November 2020 (with the exact cut-off 11th March 2020 detailed in the SAP in May 2021), 18 months prior to unblinding of the trial. This was a precaution due to the unknown impact of lockdowns and other measures in response to COVID-19 that may impact KCCQ assessment, as well as difference in terms of a higher baseline mean TSS observed in the blinded study data in patients randomised after the COVID outbreak (CSR table 14.4.2.3).

The primary composite endpoint components and secondary endpoints except KCCQ are different in nature compared to patient reported outcomes as they are based on clinical events assessed by the independent blinded adjudication committee by the same criteria throughout the trial. Furthermore, different from KCCQ, the collection of clinical events is not tied to specific time points of study visits, that is, even if a patient missed a scheduled study visit, any prior potential HF event would be captured in the database and submitted for adjudication at later visit, e.g., the study closure visit. Similarly, all deaths were captured and submitted for adjudication (vital status at the end of the trial was known for all but █ patients). Finally, while the power for KCCQ was deemed to be sufficient based on the pre-pandemic cohort, a similar cut for the primary endpoint

was simply not feasible for an event-driven trial, with limited number of primary endpoints accrued prior to the pandemic. Accordingly, at study closure when the planned target number of events for required power according to study design had accrued, █% of total patient years of follow-up were after the start of the pandemic.

EQ-5D was only summarised descriptively by treatment group in the CSR (table 14.2.7.3) with no analysis of treatment effect and above considerations of impact of the pandemic on patient reported outcomes were considered less relevant.⁹

c) Comment on the differences in results for the █ and all randomised patients in Table 14.2.4.3 of the CSR and whether this provided a rationale to focus on the █;

Firstly, we note that while the question addresses the primary analysis in the pre-pandemic population versus the analysis in the full population, which will be discussed below, it is referring to Table 14.2.4.3 of the CSR.⁹ This table reports a sensitivity analysis corresponding to the primary analysis of KCCQ-TSS, also in the pre-pandemic population, using an alternative ranking of death where patients who died were given equal (worst) rank, while in the primary analysis, the deceased were ranked based on their last change from baseline in KCCQ-TSS. The results of this sensitivity analysis were consistent with the primary analysis.

The result of the primary analysis of change from baseline in KCCQ-TSS at 8 months (CSR Table 14.2.4.1⁹) in the pre-pandemic population resulted in a win ratio of █ (95% CI: █, █) p=█, which was consistent with the analysis including the full study population (CSR Table 14.4.2.4⁹, win ratio: █ (95% CI: █, █) p=█.)

As discussed in b) above, the precaution taken to base the primary analysis of KCCQ on the pre-pandemic was specified prior to unblinding of the trial. The consistency of the results in the pre-pandemic and full population did not provide additional rationale to further focus on the pre-pandemic population for the purpose of estimating the treatment effect compared to placebo. Accordingly, in a draft manuscript, Kosiborod *et al.* based their analysis on the full population and their analyses of mean change of KCCQ scores were included in the submission (Table 14 and Figure 12 respectively).¹⁷

The corresponding subgroup analyses of KCCQ-TSS requested in A1 f) and g) are also based on the full population. We have replicated the overall analyses of Kosiborod *et al.* in the full population and pre-pandemic population (analysis of means presented in an appendix to this response document in Table 32 and Table 33 responder analyses in Table 35 and Table 36).¹⁷

These results provide further support for the consistency of treatment effect between the full and pre-pandemic populations. If anything, █ for improvement in the pre-pandemic analysis suggests that inclusion of the pandemic data is conservative in terms of estimating the treatment effect, possibly due to less room for improvement due to a █ baseline TSS.

d) How imputation was performed for those that had the 8-month follow-up visit █, and confirm the proportion

in each arm that required data to be imputed (for the [REDACTED] and total randomised populations, at baseline and month 8).

Patients who died prior to 8 months were not imputed as they were included in the analysis with worst rank. Within the deceased, patients were ranked by their last change in TSS. The imputation of KCCQ-TSS in patients alive in the study at 8 months with missing assessment was done sequentially, i.e., chronologically with the imputation at each time point informed by preceding time points. The imputation model included treatment group, T2DM randomisation stratum, prior KCCQ-TSS (at baseline, month 1 and month 4), and three categorical variables representing the number of investigator-reported HF events (categorised as 0, 1 or ≥ 2) in the intervals from randomisation to 1 month, from 1 to 4 months, and from 4 to 8 months, respectively. The imputation was done using a predicted mean matching multiple imputation model as implemented in SAS procedure MI, which ensured that imputed TSS values remained in the permissible range of 0–100. The resulting test statistics and standard errors from the analysis of each imputed dataset were combined using Rubin's rule as implemented in SAS procedure MIANALYZE.

Table 14.2.4.2 (TSS at page 5 of 10) shows the number and proportion of patients with missing data which accordingly were imputed as above at each time point in the pre-pandemic population.⁹ The denominator is patients alive in the study at the given time point.

At 8 months, [REDACTED]% in dapagliflozin group and [REDACTED]% in the placebo group had missing TSS which was imputed. The corresponding numbers for the full population are found in Table 14.4.2.3 ('All randomized') where [REDACTED]% and [REDACTED]% respectively were imputed at 8 months.

A7. Priority question. In Section B.3.3.3 of the company submission, the last observation carried forward method (LOCF) is described for missing data on the KCCQ-TSS to obtain transition probabilities. Please clarify the following:

a) Why this method was thought to be appropriate;

Please note that the LOCF referenced in the derivation of the transition probability matrices required for the health economic modelling does not refer to an imputation of missing data. It represents the maintenance of the last clinical assessment of a patient in the absence of updated evidence of patient state. This approach reflects real world clinical practice, where, in the absence of any new measurement (in this case, KCCQ-TSS), patient health state is taken as stable until new information is obtained that may inform a change in state potentially leading to a change in care. Missing data are not imputed.

b) The proportion with missing data in each arm that required imputation for each month;

Counts of transitions among health states were aggregated over the 0–4 month period and the period from 4 months onwards. Previous studies of dapagliflozin and other sodium glucose transporter-2 inhibitors have demonstrated a difference in trajectory during the early (0-4 months) phase in the corresponding trials that stabilises in the period from 4 months onwards.^{14, 18, 19} To capture this difference in disease progression trajectory between the intervention and placebo, separate matrices of transition probabilities are determined for the two treatment arms in two

separate phases of the trial, from 0-4 months and 4 months onwards, thereby creating four matrices. The corresponding matrix is applied in each month of the health economic model according to treatment arm and trial phase.

Missingness (defined as the absence of data at a collection point where data should have been available) is therefore only relevant in the context of patients' not having a measurement in either of these separate phases. Overall in the intention-to-treat population, [REDACTED] ([REDACTED]%) of patients had no KCCQ-TSS data available across either phase ([REDACTED] [REDACTED]%) placebo and [REDACTED] [REDACTED]%) dapagliflozin).³ As noted, data for these missing patients were not imputed. In the health economic model, since one transition matrix is applied monthly per treatment arm/phase, there were no missing data imputed on a monthly basis.

c) Why the use of LOCF here differs to the [REDACTED] described for KCCQ-TSS analyses in the CSR (page 48).

The CSR presents analyses of the clinical results of the DELIVER trial. The transition probability matrices were calculated to model disease evolution over the course of the trial. In the former analyses, changes in KCCQ-TSS are assessed as a trial endpoint with a specific focus on assessment at study visits. The rationale for imputation was to not bias the analysis against data missing for reasons other than death. In contrast, the health economic modelling employs KCCQ-TSS as an indicator of health state, not as an endpoint for inferential testing. All data, independently of baseline and 8-month study visit presence, were used in the analysis to provide as complete a representation of patient health state as was available in the data. Since all additional data were employed independently of study visit, there was no need to impute data not observed at defined timepoints.

A8. Priority question. In the company submission, change from baseline results for KCCQ scores are only provided as results for dapagliflozin relative to the placebo group. Please clarify or confirm the following:

a) That baseline values for the four scores in Table 14 of the submission can be found in Table 14.2.4.2 of the CSR;

Table 14 of the submission is based on the analyses by Kosiborod *et al.*¹⁷ in the full population, while Table 14.2.4.2 is based on the pre-pandemic population.⁹ Mean baseline TSS for the full population are found in CSR Table 14.4.2.3, as well as for the pre-pandemic population (randomised and 8 months visit prior to pandemic), mixed population (randomised prior, 8 months visit during the pandemic) and the pandemic population (randomised and 8 months visit during the pandemic).⁹ The mean baseline TSS was [REDACTED] in the pandemic population, however as the majority of subjects were randomised prior to the pandemic, the baseline TSS means in the full population were only marginally impacted and similar to those of the pre-pandemic population.

Mean baseline values in CSR Table 14.4.2.3 are based on all available baseline measurements. However, in Table 32 for the full population and Table 33 for the pre-pandemic population, provided as support to the requested subgroup analyses in A1 f), mean baseline values alternatively include patients alive in the study at 8 months contributing to change from baseline.

Reassuringly, the mean baseline values [REDACTED] between the two calculation approaches.

- b) Why the mean change from baseline per arm in Table 14.2.4.2 of the CSR does not appear to lead to the same results as in Table 14 for dapagliflozin vs placebo (e.g. for KCCQ-TSS at 8 months, the mean values in the CSR suggest a difference in mean change from baseline score of [REDACTED] rather than 2.40).**

Table 14.2.4.2 is based on the pre-pandemic population, while values in Table 14 of the submission are the analyses of the full population from Kosiborod *et al.*¹⁷. The corresponding change from baseline of TSS by treatment group in the full population is reported in CSR Table 14.4.2.3.⁹ However, the difference in mean change from baseline between treatment groups was estimated in a mixed model repeated measures analysis adjusted for baseline and will be numerically different, in this case [REDACTED], than the difference between the crude mean changes reported on the tables.

In fact, the estimated difference in mean change from baseline between dapagliflozin and placebo [REDACTED] in the full population (Table 32) and the pre-pandemic population (Table 33), [REDACTED], respectively, again providing reassurance that the estimated treatment effect compared to placebo was [REDACTED] between the full and pre-pandemic population.

Other outcomes

A9. Priority question. Please provide the number of patients with fractures in each arm of the DELIVER trial in B.2.12.1 of the submission.

These data are provided in Table 11. The number of patients experiencing a SAE of fracture was [REDACTED] across both treatment arms.

Table 11: Patients with any SAEs of fracture

	Number of patients (%)	
	Dapagliflozin (N=3,126)	Placebo (N=3,127)
Patients with any SAE of fracture	[REDACTED]	[REDACTED]

Source: AstraZeneca UK Ltd. Data on File.³

Abbreviations: SAE: serious adverse event.

A10. Priority question. In terms of the Clinical Practice Research Datalink (CPRD) UK dataset that was used to inform a scenario in the model for baseline characteristics:

- a) Does the CPRD dataset represent those treated with SoC with an EF >40%?;**

Overall, the Clinical Practice Research Datalink (CPRD) study included, out of the [REDACTED] patients with a diagnosis of HF, [REDACTED] patients with HF who had a record of EF measurement, of which [REDACTED] had an LVEF >40%.²⁰ This highlights that the measurement of LVEF has not always been recorded well in Read codes. The baseline characteristics used in Scenario 13 (as detailed in Section B.3.3.3 in Document B), were representative of these [REDACTED] patients with HF and an LVEF >40%.²⁰

In response to the EAG's question, it should be noted that there is no disease modifying standard of care for these patients; as such, treatment with standard of care is referring only to the use of symptom relieving therapies that are typically used for this patient population in clinical practice.

b) Please confirm whether asymptomatic patients could be included in the CPRD dataset, as suggested by the inclusion of [REDACTED]. If so, please comment on how reflective this dataset is of the decision problem, given that it specifies symptomatic patients with heart failure with preserved ejection fraction (HFpEF);

Patients with HFpEF present with a significant number of symptoms, which are not often recorded in routine practice. From an electronic health records (EHR) perspective, the limitations of the medical histories and available records of investigations for each patient only provide a limited indication when it comes to the prognosis for each patient. Apart from typical symptoms and signs of HF, other diagnostic processes for patients with HF and an LVEF >40% include NT-proBNP and echocardiography, which are also very sparsely recorded in routine practice. In routine clinical practice, asymptomatic patients are not proactively offered any of these diagnostic tests.

Therefore, it may be assumed that any patients with a diagnosis of HF have been referred as a result of experiencing signs and symptoms of HF, thus being symptomatic. Although symptomatic classification has been a major entry criterion for RCTs that support HF treatment guidelines, accessing the full results from patients' EHR is a major challenge. Given that diagnosis relies on a combination of these assessments as well as symptomatology, the absence of these measurements is likely to introduce bias due to misclassification.

Although we have characterised the patient population based on a diagnosis code for HF in both primary care and secondary care, missing data remains, including for the NYHA functional status records. Approximately [REDACTED]% of the patients with known record for ejection fraction measurement in our data do not have a record for NYHA classification.²⁰ Therefore, excluding patients with NYHA I (approximately [REDACTED]% of the population with EF measure) may only reduce the level of bias but not eliminate it completely and would have a negligible impact on the data overall.

The only other proxy for excluding asymptomatic patients would be to apply additional measures such as hospitalisation for HF based on ICD-10 codes in the first position, indicating the primary reason for hospitalisation was HF, providing more assurance that the patients included are symptomatic. Then, a further exclusion of patients with known record of NYHA I class within the 12 months prior to baseline may be applied, as a proxy for asymptomatic cases. However, this would impact on the sample size for the analysis cohort and would inappropriately limit the data to only those hospitalised, excluding patients treated in the outpatient setting. It is, therefore, inappropriate for this patient population since the baseline event rate is lower so many will not

have had a HF event warranting hospitalisation and will have been discharged back to primary care for management after diagnosis so this approach would remove many patients. There is no other realistic means of identifying asymptomatic patients leaving the inclusion of patients with a recorded HF diagnosis and LVEF measurement as the most appropriate approach.

As described in Document B of the submission materials, while there are some differences between DELIVER and UK clinical practice, UK clinical experts generally agreed that the trial is broadly representative of UK clinical practice. Nonetheless, AstraZeneca recognise these differences and have, therefore, performed a scenario analysis using the CPRD dataset in addition to using the DELIVER trial cohort in the base case cost-effectiveness analysis to reduce uncertainty.

Finally, it is important to note that the scenario analysis using the baseline characteristics from the CPRD had a negligible impact on the ICER, compared to the use of baseline characteristics from the DELIVER trial. As such, any minor changes to the CPRD analysis inclusion/exclusion criteria would be unlikely to ultimately have any meaningful impact on the cost-effectiveness of dapagliflozin in this scenario.

c) Were any outcomes collected and available from the CPRD dataset? If so, please provide data for outcomes that were collected for comparison against the DELIVER trial;

Of relevance to this submission, the purpose of the CPRD analysis was to understand the epidemiology of HF with an LVEF >40% in a real-world setting in the UK and to provide an overview of the patient characteristics of this patient group at a national level.²⁰

Analysis of outcomes was not conducted as part of this CPRD study, given the uncertainty that would be associated with any outcomes collected via the CPRD analysis, when compared to the DELIVER trial. The DELIVER trial can be considered generalisable to UK clinical practice,²¹ and as a randomised controlled trial (RCT),¹ represents a substantially more robust source of evidence, compared to retrospectively collected real-world evidence which would not be subject to the same rigour of inclusion/exclusion criteria and study protocols. This is aligned with the NICE manual, which highlights that “for relative treatment effects, there is a strong preference for high-quality randomised controlled trials (RCTs)”.²²

As such, even if outcomes data from the CPRD analysis were available, there would be no rationale for the use of these to inform the efficacy data in this submission, compared to the results of the DELIVER trial.

d) If any outcomes are different between the DELIVER and the CPRD dataset, please provide a rationale for this.

As previously detailed in response to Question A10, Part C, outcomes data were not available from the UK CPRD study, so this question is not applicable.

A11. Priority question. Please clarify why Table 22 of the submission differs in terms of the number of patients experiencing any major hypoglycaemic event

compared to the value in Table 43 of the CS. Should the total number of patients across arms be 13 in Table 43 rather than [REDACTED]?

The value of 13 patients in Document B, Table 22 solely relates to patients experiencing any major hypoglycaemic event whilst on treatment,¹ whilst the [REDACTED] patients in Document B, Table 43 includes patients experiencing an event both on and off treatment.⁹ The differences in AEs between these two groups are also reported explicitly in Table 25 of the DELIVER clinical study report, summarised in Table 12 below.⁹

Table 12: Number of patients with any major hypoglycaemic event in any category (SAS)

AE category	Number (%) of patients			
	On treatment		On and off treatment	
	Dapagliflozin 10 mg	Placebo	Dapagliflozin 10 mg	Placebo
Any major hypoglycaemic event	6 (0.2)	7 (0.2)	[REDACTED]	[REDACTED]

Abbreviations: AE: adverse event; SAS: safety analysis set.

Sources: Solomon *et al.* (2022);¹ DELIVER CSR.⁹

A12. Please clarify why the thresholds for small, moderate and large improvements and/or deterioration in KCCQ-TSS score in the submission differ to those described in the CSR (Figure 12 of the submission vs Table 21 of the DELIVER CSR).

For the regulatory submission, the Company derived study specific thresholds for clinically meaningful changes in TSS based on FDA guidance,²³ applying anchor-based analyses of KCCQ-TSS and patient global impression of severity (PGIS), to the blinded DELIVER study data prior to database lock, resulting in ≥ 13 points ('small to moderate') and ≥ 17 points ('large') improvement and ≥ 5 points ('moderate') and ≥ 14 ('large') deterioration which were used in responder analyses. Figure 12 of the submission, however, is based on the Kosiborod *et al* draft manuscript, who applied traditionally [REDACTED]

Baseline characteristics and study procedures

A13. Priority question. There is a discrepancy between Table 8 of the submission and Table 29 of the submission in terms of the proportion with an eGFR <60 mL/min/1.73m². Should this be [REDACTED] rather than [REDACTED] in Table 29? As this feeds into the base case of the economic model, please ensure this is also corrected there if required.

The proportion of patients with an eGFR <60 mL/min/1.73m² should be [REDACTED]%, rather than [REDACTED]%.⁹

Based on this, the Company has updated its base case to include this minor correction to the proportion of patients with an eGFR <60 mL/min/1.73m². The revised base case economic analysis results expressed in terms of incremental cost-effectiveness ratios (ICERs) and net

monetary benefit (NMB) are presented in the Revised Base Case Section at the end of this response document, in Table 28 and Table 29, respectively.

A14. For treatments other than loop diuretics recommended specifically for the HFpEF (>40%) population, such as beta-blockers or angiotensin converting enzyme (ACE) inhibitors, please provide a breakdown of the proportion that were using these to treat comorbidities only and the proportion that were using them for the treatment of heart failure (e.g., maintained if they were previously <40%, or used in mildly reduced EF group 40-49%).

The proportions of patients receiving HF and CV medication at randomisation in DELIVER has previously been provided in Document B, Section B.2.3.2, Table 8. The DELIVER trial was not designed to collect more detailed information on the medication history for each patient, and, therefore, the data requested by the EAG are not available and cannot be provided.

Furthermore, as previously detailed in Document B, Section B.1.3.5, it is important to reiterate that there are no treatments that are recommended specifically for the treatment of patients with HF and an LVEF >40%. While patients with HF and an LVEF >40% may have multiple varying co-morbidities for which they are separately treated, SoC for symptom management of HF and an LVEF >40% in UK clinical practice predominantly comprises treatment with loop diuretics (typically furosemide or bumetanide).²⁴

A15. In the DELIVER trial, [REDACTED] are reported to have valvular heart disease. The EAG's clinical experts indicate that those with valve disease, such as aortic stenosis or mitral regurgitation, may be classed as having valvular heart failure rather than HFpEF. Please provide a breakdown of the types of valve disease these patients had and the rationale for including this group of patients in the trial, including whether it is clinically plausible that results in this group may differ to patients without valvular heart disease.

As reported in the DELIVER CSR, patients with HF due to uncorrected primary valvular disease were excluded from the trial and different types of valve disease have not been assessed systematically in DELIVER.⁹ Therefore, the [REDACTED]% did not include any patients where the valvular disease was considered to be of sufficient severity for the valvular disease to be the primary diagnosis. Specifically, patients with HF due to uncorrected primary valvular disease (exclusion criteria 13), based on investigators' judgement, and patients with valve repair/replacement within 12 weeks prior to enrolment were excluded.²⁵

A16. Heart failure medications in accordance with local guidelines are mentioned in the submission for heart failure treatments and comorbidities. Please provide details of the doses for each drug that were considered to be optimum. Please comment on

any possible differences between optimised doses in the trial and those recommended by NICE in the UK.

The relevant comparator for dapagliflozin is placebo in addition to SoC, which currently involves treatments for the symptoms of HF, such as loop diuretics for congestive symptoms and fluid retention.⁶ There are currently no disease-modifying treatments recommended for patients with HF and an LVEF >40% to which an optimum dose could be applied.⁶ According to UK clinical expert feedback, the loop diuretics most commonly prescribed in UK clinical practice are furosemide and bumetanide.^{24, 26, 27}

There are no specific optimum doses for these drugs recommended by NICE.²² For the purposes of the cost-effectiveness model, doses of 40 mg orally once daily for furosemide and 1 mg orally once daily for bumetanide were assumed to best represent UK clinical practice and are representative of the individual SmPCs. However, given the absence of detailed dosing recommendations for UK clinical practice, as well as the fact that no particular dosing schedule was mandated for patients in the DELIVER trial, it is not possible to make any comparisons between the usage of loop diuretics in DELIVER versus UK clinical practice.

A17. Please comment on whether there was any assessment during the DELIVER trial of how well-controlled diabetes was in those with T2DM. If so, please state the proportion that may have experienced poor diabetes control in each arm throughout the trial and the impact this might have had.

T2DM progression was not monitored as part of the protocol for the DELIVER trial.¹¹ Glycosylated haemoglobin (HbA1C) is a common indicator of T2DM status and these data were collected at baseline, but not subsequently over the course of trial follow-up.

A18. Deviations in study procedures and assessments are reported for [REDACTED] in each treatment group of the DELIVER trial (Table 14.4.1.2.1 of the CSR). Please clarify the types of deviations this included.

The most common COVID-19-related non-important protocol deviation was related to [REDACTED]. As referred to in Question A18, [REDACTED] of the patients had COVID-19-related protocol deviations categorised as [REDACTED], [REDACTED] in the Dapagliflozin arm, [REDACTED] in the placebo arm (see Table 14.4.1.2.1 in CSR and Table 3 in Appendix 16.1.13). These protocol deviations were reported based on the [REDACTED], Section 8.1 [REDACTED].²⁸

[REDACTED]

1. [REDACTED]
[REDACTED]
[REDACTED]

2. [REDACTED]
[REDACTED]
[REDACTED]

3. [REDACTED]

The types of deviations listed above were guidance on how to submit non-important protocol deviations related to COVID-19. There was no further subcategorisation within the category 'Study procedures and assessments'. Detailed information regarding each protocol deviation under the category 'Study procedures and assessments' were recorded as free text (see examples under 1-3 above).

The COVID-19-related protocol deviations did not raise any concerns regarding study conduct, safety of patients, or study conclusions.

Section B: Clarification on cost-effectiveness data

Please note:

If as a result of the responses to the clarification questions the company revises its base case, please indicate what assumptions are considered for the revised base case and provide updated results including updated probabilistic sensitivity analyses, deterministic sensitivity analyses and scenario analyses.

Please provide the ICER and net monetary benefit using willingness-to-pay thresholds of £20,000 and £30,000 when presenting these results. The NHB is not required. When presenting the results of OWSA, please provide the ICER (rather than the NHB).

Please provide all requested scenario analyses as options in the economic model and on top of any revised assumptions.

Adverse events

B1. Priority question. Please explain why renal events were removed from the model (in comparison to the dapagliflozin model used in TA679). Clinical expert opinion provided to the EAG noted that clinical events are equally relevant for the preserved ejection fraction (pEF) population.

The model built for DELIVER is de-novo based on the DELIVER patient data and is not an adaptation of the DAPA-HF model. The DELIVER model uses the same methodology as the DAPA-HF model and so renal events such as acute kidney injury (AKI) were included as an AE in this model.²⁹ In the DAPA-HF trial, renal events were adjudicated to consist of multiple renal-related events (chronic dialysis, renal transplant, renal death);¹² however there was no adjudicated renal endpoint in the DELIVER trial.⁹ The CSRs for the two trials highlight the limited collection of renal events and variation in creatinine collection for eGFR assessment which was much more limited in DELIVER:

- DAPA-HF- Creatinine collected at all visits (every 4 months) with, unscheduled resampling 4 weeks after a 50% eGFR decline, or eGFR <15 to assess criteria for sustained decrease for efficacy endpoint
- DELIVER- Creatinine/eGFR Collection for safety assessment 1, 4, 12 months and thereafter annually. Used for explorative objective for change from baseline in eGFR/slope

In addition, no collection of renal efficacy events occurred in the DELIVER trial and renal AE were not an AE of interest. Renal SAEs/DAEs were only collected as part of the general collection of SAE/DAEs.⁹

The definition of renal events is broad, and encompasses several different types of events such as AKI, dialysis and eGFR decline. The costs/disutility associated for each event type would be different. Therefore, it is not recommended to group these events into one category termed ‘renal events’.

It is therefore inappropriate to include anything more than the AE of AKI in the model, and this should be considered sufficient to inform the impact of dapagliflozin on renal endpoints. Dapagliflozin has demonstrated proven renal benefits and whilst a decision was made not to include anything beyond AKI events, there are likely other uncaptured renal benefits and therefore the ICER can be considered to be a conservative estimate.

B2. Priority question. Using the table below, please fill in the number of amputations per treatment arm of the DELIVER trial for those with and without T2DM. Please conduct a scenario analysis in the model where amputation is excluded.

A summary of the amputations per treatment arm in DELIVER is provided in Table 13, demonstrating that a [REDACTED] of amputations occurred in the placebo + SoC arm for patients with T2DM, compared to patients with T2DM receiving dapagliflozin.

Table 13: Summary of amputations in the DELIVER trial by T2DM status

	Number of patients with amputations in the DELIVER study (N=[REDACTED])	
	Dapagliflozin + SoC	Placebo + SoC
With T2DM	[REDACTED]	[REDACTED]
Without T2DM	[REDACTED]	[REDACTED]

Abbreviations: SoC: standard of care; T2DM: type 2 diabetes mellitus.

Source: AstraZeneca UK Ltd. Data on File.³

The deterministic results of this scenario analysis, where amputation has been excluded as an AE in both treatment arms, are presented in Table 14.

Please note that for continuity with the original submission, the scenarios presented previously in Document B, Table 62 have been numbered as Scenarios 1–13 throughout this response. The new scenarios conducted as part of this response document have been numbered from 14 onwards (therefore this scenario conducted in response to QB2 is labelled as Scenario 14).

Please also note that as previously detailed in response to QA13, the Company has updated its base case to include a minor correction to the proportion of patients with an eGFR <60 mL/min/1.73m². The revised base case economic analysis results expressed in terms of ICERs and NMB are presented in Table 28 and Table 29, respectively. All of the scenarios presented throughout this response have been conducted based on this revised base case. Full probabilistic and deterministic results for all scenarios can be found in Table 31 of the Revised Base Case results section.

Table 14: Scenario analysis excluding amputation as an AE for both treatment arms

Scenario analysis description	Deterministic results		
	Incremental costs	Incremental QALYs	ICER
Base case (following clarification questions)	£1,885	0.251	£7,519
Scenario 14 (excluding amputation as an AE for both treatment arms)	£2,109	0.247	£8,538

Abbreviations: AE: adverse event; ICER: incremental cost-effectiveness ratio; QALYs: quality-adjusted life years.

B3. Priority question. Please discuss the clinical plausibility of the differences in probabilities of adverse events in both intervention and comparator arms between the DELIVER and DAPA-HF trials given the similarities in adverse event frequency. For example, the probability of volume depletion in the SoC arm of the TA679 cost effectiveness model was 0.045 while in the DELIVER model the probability is [REDACTED]. The EAG notes the difference in median trial duration. Please conduct a scenario analysis in the model using the DAPA-HF adverse event probabilities.

Direct comparison of the data from the DELIVER and DAPA-HF trials is inappropriate, lacks scientific rigour and is associated with substantial uncertainty. Primarily, this is due to the distinct patient populations included within the two trials: the DELIVER trial recruited patients with HF and an LVEF >40%, compared to DAPA-HF, which recruited patients with HF and an LVEF ≤40%.¹

In addition to LVEF, a side-by-side comparison of the baseline characteristics between the two trials highlights fundamental differences in the two patient populations meaning they are not directly comparable. For example, the DELIVER trial had a mean age of 71.7 years, 5.4 years older than the mean age of 66.3 in the DAPA-HF trial.^{1,29} Similarly, [REDACTED]% of patients were female in DELIVER, compared to 23.4% in DAPA-HF.^{1,9}

The heterogeneity between the two trials is compounded by differences in the study designs, such the difference in the median trial follow-up duration, with a median duration of follow-up of 2.3 years at the time of the latest data-cut off in DELIVER, compared to 18.2 months in DAPA-HF.^{1, 10} [REDACTED]

Given the differences between the two trial populations, any comparison of outcome data between DAPA-HF and DELIVER is associated with substantial limitations and cannot be considered robust. As such, while the probabilities of AEs differ between DELIVER and DAPA-HF, this does not represent a major source of uncertainty.

As requested, deterministic results of a scenario analysis using the AE rates from the DAPA-HF trial has been presented in Table 15, resulting in a slight increase to the base case ICER. Full probabilistic and deterministic results for all scenarios can be found in Table 31 of the Revised Base Case results section.

However, given the fundamental differences between DAPA-HF and DELIVER, this scenario analysis must be interpreted with caution, and is less robust than the base case economic analysis, which utilises more relevant AE data derived directly from DELIVER, which included the patient population of relevance to this submission.

Table 15: Scenario analysis using the AE probabilities from DAPA-HF

Scenario analysis description	Deterministic results		
	Incremental costs	Incremental QALYs	ICER
Base case (following clarification questions)	£1,885	0.251	£7,519
Scenario 15 (using the AE probabilities from DAPA-HF)	£2,077	0.246	£8,435

Abbreviations: AE: adverse event; ICER: incremental cost-effectiveness ratio; QALYs: quality-adjusted life years.

B4. Priority question. What was the mean length of stay for the ■■■ HHF events recorded in the DELIVER trial?

The provision of the crude length of stay (LoS) data requested by the EAG would be associated with substantial uncertainty and an unknown potential for bias. DELIVER was not tailored for hospital LoS comparison post-randomisation and patients were not randomised at time of hospital admission. In addition, death would complicate the LOS analysis. It is also conceivable that hospital LoS tends to have skewed distribution and differ between regions. Therefore, the Company is not able to provide these.

Furthermore, the generalisability of the length of stay from the DELIVER trial, which is a global trial, to patients in UK clinical practice, would be extremely uncertain. Given this, using the latest NHS Reference cost data to estimate the length of stay for patients in UK clinical practice was considered to represent the most appropriate methodology in the base case economic analysis, as further detailed in response to QB8.

B5. Priority question. Filling in the table below, please detail over how many cycles was disutility applied for each adverse event.

In the base case economic analysis, AE disutilities are applied for one cycle (the cycle length was one month, or 365.25/12 days) for each AE, as detailed in Table 16 below. AE disutilities are applied for the proportion of patients who experience AEs throughout one cycle. This is consistent with the approach adopted and accepted by the ERG and the NICE committee in TA679.¹⁰

Table 16: Summary of application of AE disutility

Adverse event	Number of cycles^a with disutility applied
AKI	1 cycle
Fracture	1 cycle
UTI	1 cycle
Volume depletion	1 cycle
Amputation	1 cycle

^a Each cycle had a length of one month, or 365.25/12 days.

Abbreviations: AE: adverse event; AKI: acute kidney injury; UTI: urinary tract infection.

Costs and resource use

B6. Priority question. Please justify the number of GP visits used to cost the KCCQ quartile health states. Clinical expert opinion provided to the EAG suggests pEF populations are more likely to have 5-6 GP visits per year instead of the [REDACTED] assumed in the model. Please include a scenario analysis in the model which allows for 6 annual GP visits in addition to the A&E referrals and cardiologist visits.

The base case economic analysis assumes that patients have [REDACTED] GP visits per year, although notably, this is distributed across various types of GP visits, including outpatient office visits, GP home visits and GP phone calls to patients, as detailed in Document B, Table 51.

This combined estimate of [REDACTED] GP visits was based on McMurray *et al.* (2018), which uses UK real-world evidence derived from a Clinical Practice Research Datalink (CPRD) study in the UK.³⁰ This estimate should therefore be considered to be robust, and reflective of the patient experience in UK clinical practice. McMurray *et al.* (2018) was also used as the source of the resource estimates, including GP visits, in TA679.¹⁰

In response to Question B6, a scenario analysis has been provided which assumes that patients only receive 6 GP visits per year. The results are presented in Table 17 below and demonstrate that this scenario decreases the base case ICER. As such, the base case assumption of 23.14 GP visits could be considered conservative.

Full probabilistic and deterministic results for all scenarios can be found in Table 31 of the Revised Base Case results section.

Table 17: Scenario analysis allowing for 6 GP visits per year

Scenario analysis description	Deterministic results		
	Incremental costs	Incremental QALYs	ICER
Base case (following clarification questions)	£1,885	0.251	£7,519
Scenario 16 (caps the total number of GP visits per patient per year to 6)	£1,711	0.251	£6,826

Abbreviations: GP: general practitioner; ICER: incremental cost-effectiveness ratio; QALYs: quality-adjusted life years.

B7. Priority question. Please include a scenario analysis in the model where costs related to non-elective long stay (hospitalisation for heart failure [HHF], acute kidney injury [AKI], amputation, fracture) and urgent heart failure visit (UHFV) are taken from the NHS References Costs 2019/20 allowing inflation to the 20/21 cost year.

As requested, a scenario analysis has been explored by applying the NHS References Costs 2019/20 for costs related to non-elective long (NEL) stay (i.e., HHF, AKI, amputation, and fracture) and UHFV. All costs have been inflated to 2020/21 using the NHS cost inflation index (NHSCII) based on an inflation factor of 3.08%.³¹

As the inflated costs from the year 2019/20 are generally lower than that of the year 2020/21, the total costs are lower in both treatment arms for this scenario analysis. However, due to the higher event rates in the SoC arm, the cost reduction is higher for patients in the SoC arm, leading to a lower incremental cost of dapagliflozin + SoC against SoC compared to the company base case. Therefore, the ICER increases marginally, and is still notably well below the £20,000–£30,000/QALY gained threshold.

Full probabilistic and deterministic results for all scenarios can be found in Table 31 of the Revised Base Case results section.

Table 18: Scenario analysis using NEL (HHF, AKI, amputation and fracture) and UHFV costs based on NHS Reference Costs 2019/20 with Inflation

Scenario analysis description	Deterministic results		
	Incremental costs	Incremental QALYs	ICER
Base case (following clarification questions)	£1,885	0.251	£7,519
Scenario 17 (use non-elective long term and day cases NHS References 2019/20 costs inflated to the 20/21 cost year)	£2,046	0.251	£8,161

Abbreviations: AKI: acute kidney injury; HHF: hospitalisation for heart failure; ICER: incremental cost-effectiveness ratio; NEL: non-elective long-stay; QALY: quality-adjusted life years.

B8. Priority question. The EAG has been advised by clinical experts that the average length of stay for HHF for a patient from the pEV population would be approximately 11 days. Given that the more severe cost code used to cost HHF (EB03A) is associated with a 53-day long hospitalisation, whereas the less

severe cost code (EB03E) is associated with 13 days in hospital, please justify the weighted average approach to costing HHF. Please conduct a scenario analysis in the model using the cost code EB03E from the NHS Reference costs 2019/20 (inflated to the 20/21 cost year) to calculate the cost of all HHF events in the model.

It is unclear where the length of stay estimates provided by the EAG have been derived from – please could the EAG provide further details of the source document for the estimates of 53-day and 13-day hospitalisation for EB03A and EB03E.

While it is acknowledged that the NHS Reference cost data are not specific to HHF for patients with HF and an LVEF >40%, they should be considered to represent the best available proxy, given the paucity of alternative resource use data for the population of patients with HF and an LVEF >40% specifically in the UK in the published literature.

As such, the weighted average of the heart failure cost codes derived from the NHS Reference costs should be considered to represent an average of the most recent patient experience across the breadth of the UK over the last two years.

A scenario analysis has been conducted using the 2019/2020 cost for EB03E, inflated to 2020/21 using the NHS cost inflation index (NHSCII) based on an inflation factor of 3.08%.³¹ The results are summarised in Table 19 below. Full probabilistic and deterministic results for all scenarios can be found in Table 31 of the Revised Base Case results section.

However, for the reasons detailed previously, the results of this scenario analysis should be considered extremely conservative, and likely underestimate the true costs associated with HHF, and consequently, the potential cost-savings that will result from the reduced incidence of HHF associated with dapagliflozin.

Table 19: Scenario analysis using the NHS cost code EB03E to cost HHF events

Scenario analysis description	Deterministic results		
	Incremental costs	Incremental QALYs	ICER
Base case (following clarification questions)	£1,885	0.251	£7,519
Scenario 18 (using the NHS cost code EB03E to cost HHF events)	£2,122	0.251	£8,466

Abbreviations: HHF: hospitalisation for heart failure; ICER: incremental cost-effectiveness ratio; NHS: National Health Service; QALY: quality-adjusted life years.

Utilities

B9. Priority question. Please discuss the clinical plausibility of the considerably lower HHF-related disutility value estimated from the DELIVER population compared with the DAPA-HF population (█ vs 0.321,

respectively). Please provide a scenario using the HHF disutility as measured in the DAPA-HF study.

Please note that the disutility from DAPA-HF (0.321) is an annual estimate of disutility. The corresponding HHF disutility that was used in the DAPA-HF cost-effectiveness model was 0.027 (0.321/12), closely aligning with the disutility of 0.025 from the DELIVER trial.

Regardless of this, as previously detailed in response to Question B3, direct comparisons between the DAPA-HF and DELIVER trials are associated with limitations and substantial uncertainty. As such, it is inappropriate to directly compare health-related quality of life estimates between the two trials.

The disutility of [REDACTED] has been derived directly from the DELIVER trial,⁹ which represents the patient population of relevance to this submission. There is no clear rationale to use an alternative, less relevant disutility from an alternative trial, which included a different patient population to the target patient population in this submission and focussed on an indication where the standard of care treatments are vastly different compared to patients with HF and an LVEF >40%. As such, the use of a utility value from the DAPA-HF trial when data from the DELIVER trial are available would risk seriously undermining the credibility and generalisability of the economic analysis.

For these reasons, it was not considered appropriate to conduct a scenario analysis using the disutility for HHF derived from DAPA-HF.

B10. Priority question. The company has used KCCQ utility values for the pEF population that are lower than those in their previous submission for the reduced ejection fraction (rEF) population (TA679). Please discuss the validity of quartile utilities used in scenario 13, where an adjustment is made using general population utilities, given these exceed the equivalent scenario in TA679.

As previously detailed in response to Question B3, direct comparisons between the DAPA-HF and DELIVER trials are associated with limitations and substantial uncertainty. As such, it is inappropriate to directly compare health-related quality of life estimates between the two trials.

In response to Question B10, it should be noted that the Company has identified a minor error in the utility values used in Scenario 13 presented in Document B, Table 62. The corrected utility values informing this scenario are presented Table 22, below, and the updated deterministic results of this scenario are presented in Table 21 below. Full probabilistic and deterministic results for all scenarios can be found in Table 31 of the Revised Base Case results section.

Following the updates to the utility values used in Scenario 13, it should be noted that both the base case utility values and the Scenario 13 utility values are lower than the KCCQ-TSS values used in the base case and corresponding scenario in TA679, respectively. As such, the utility values included in Scenario 13 should not be associated with any validity concerns.

Table 20: Summary of KCCQ health state utility values used in the base case and Scenario 13

Health state	Base Case ^a	Scenario 13 ^b
KCCQ-TSS Q1	■	■
KCCQ-TSS Q2	■	■
KCCQ-TSS Q3	■	■
KCCQ-TSS Q4	■	■

Footnotes: ^a Derived directly from the DELIVER trial (Document B, Table 45). ^b The utility value for KCCQ-TSS Q4 was set equal to the age-adjusted utility value in the general population, and the utility values for Q1–3 were derived by applying the decrements between Q1–Q3 and Q4 from the table above, to the general population utility value used for Q4.

Abbreviations: KCCQ: Kansas City Cardiomyopathy Questionnaire; SE: standard error; TSS: total symptom score.

Source: DELIVER CSR⁹

Table 21: Summary of updated scenario analysis results for Scenario 13

Results	Deterministic results		
	Incremental costs	Incremental QALYs	ICER
Base case (following clarification questions)	£1,885	0.251	£7,519
Scenario 13	£1,885	0.237	£7,955

Abbreviations: ICER: incremental cost-effectiveness ratio; QALY: quality-adjusted life year.

B11. Priority question. Given the incremental differences in utility between each KCCQ quartile in the DELIVER trial, discuss the clinical plausibility of differences between quartiles when utilities are adjusted to population norms as used in scenario 13. Please show the calculations used when adjusting the utilities to population norms.

Please see the response to QB10 above regarding the minor error in Scenario 13 in Document B. Once the utility values used in Scenario 13 have been updated (as detailed in QB10 and Table 20), the utility difference between each KCCQ health state utility to the next in Scenario 13 are identical to the utility difference between each KCCQ health state utility in the base case economic analysis. As such, there are no clinical plausibility concerns related to the differences between quartiles in Scenario 13, compared to the base case analysis.

Further details on the calculation of the utilities in Scenario 13 are detailed below, as well as in Table 22 below. The utility value for KCCQ-TSS Q4 was set equal to the age-adjusted utility value in the general population, and the utility values for Q1–3 were derived by applying the decrements between Q1–Q3 and Q4 from the table above, to the general population utility value used for Q4.

In each instance, the utility between KCCQ-TSS Q4 and KCCQ-TSS Q1, Q2 and Q3 from the base case economic analysis was applied to ■ (the age and sex matched general population utility estimate used for KCCQ-TSS Q4 in Scenario 13) to derive the new health state utility values for KCCQ-Q1, Q2 and Q3.

For example, the difference between the health state utilities for KCCQ-TSS Q4 and KCCQ-TSS Q1 in the base case was ■. Therefore, the health state utility value for KCCQ-TSS Q1 in

Scenario 13 was calculated by subtracting [REDACTED] from [REDACTED], to derive a health state utility estimate of [REDACTED].

Table 22: Summary of KCCQ health state utility values used in the base case and Scenario 13

Health state	Base Case ^a	Increment	Scenario 13 ^b	Increment
KCCQ-TSS Q1	[REDACTED]	[REDACTED]	[REDACTED]	[REDACTED]
KCCQ-TSS Q2	[REDACTED]	[REDACTED]	[REDACTED]	[REDACTED]
KCCQ-TSS Q3	[REDACTED]	[REDACTED]	[REDACTED]	[REDACTED]
KCCQ-TSS Q4	[REDACTED]	[REDACTED]	[REDACTED]	[REDACTED]

Footnotes: ^a Derived directly from the DELIVER trial (Document B, Table 45). ^b The utility value for KCCQ-TSS Q4 was set equal to the age-adjusted utility value in the general population, and the utility values for Q1–3 were derived by applying the decrements between Q1–Q3 and Q4 from the table above, to the general population utility value used for Q4.

Abbreviations: KCCQ: Kansas City Cardiomyopathy Questionnaire; SE: standard error; TSS: total symptom score.

Source: DELIVER CSR.⁹

B12. Priority question. Clinical expert opinion provided to the EAG indicates that the assumption of a 1 month duration for the impact of HHF on patients' QoL is underestimated. The experts indicated that the average length of stay in the hospital for HHF for pEF patients is 11 days. Subsequently, one expert indicated that a reasonable assumption is that 1 day in hospital impacts patients' QoL for 1 week after discharge. The other clinical expert indicated that 6 months of impact (as a maximum) could also be plausible after discharge. Therefore, please conduct two alternative scenario analyses where:

- a) It is assumed that HHF events impact patients' QoL for 2.75 months after discharge;

As requested, a scenario has been explored which increases the duration for the impact of HHF on patients' health-related quality of life (HRQoL) from 1 month to 2.75 months. The ICER improves relative to the base case, as a greater number of HHF events occur in the SoC arm compared to the dapagliflozin + SoC arm, thereby reducing the total QALYs in the SoC arm and increasing the incremental QALYs.

Table 23: HHF events assumed to impact patients' QoL for 2.75 months after patients are discharged

Results	Deterministic results		
	Incremental costs	Incremental QALYs	ICER
Base case (following clarification questions)	£1,885	0.251	£7,519
Scenario 19 (the disutility from a HHF event persists for 2.75 cycles of the model)	£1,885	0.256	£7,372

Abbreviations: HHF: hospitalisation for heart failure; ICER: incremental cost-effectiveness ratio; QALY: quality-adjusted life year; QoL: quality of life.

b) It is assumed that HHF events impact patients' QoL for 6 months after discharge.

A scenario has been explored by increasing the duration for the impact of HHF on patients' HRQoL from 1 month to 6 months. As per scenario 20, the ICER improves relative to the base case given the greater number of HHF events in the SoC arm compared to the dapagliflozin + SoC arm.

Table 24: HHF events assumed to impact patients' QoL for 6 months after patients are discharged

Results	Deterministic results		
	Incremental costs	Incremental QALYs	ICER
Base case (following clarification questions)	£1,885	0.251	£7,519
Scenario 20(the disutility from a HHF event persists for 6 cycles of the model)	£1,885	0.265	£7,114

Abbreviations: HHF: hospitalisation for heart failure; ICER: incremental cost-effectiveness ratio; QALY: quality-adjusted life year; QoL: quality of life.

B13. Priority question. At what time points during the study were EQ-5D-5L measurements taken? What were the deciding factors for these time points?

EQ-5D-5L data were collected at Randomisation (Day 1), Visit 5 (Day 240 ± 7), at Premature Treatment Discontinuation Visit (if applicable), and at Study Closure Visit (≤6 weeks after the Primary Analysis Censoring Date).¹¹

The EQ-5D-5L 8-month time point was set at the same time point as the evaluation of the KCCQ-TSS (described earlier in A6a).

Mortality

B14. Priority question. [REDACTED]

[REDACTED]

[REDACTED] Please can the company provide a scenario where the rate of UHFV is the same in both treatment groups.

With respect to QB14, as well as QB15 and QB16, it is important to note the distinction between the [REDACTED] effect between treatment groups, versus clinical equivalence between treatment groups.

There are a number of articles in the published literature highlighting the limitations associated with p-values, the importance of interpreting them correctly, and the arbitrary nature regarding the 5% cut-off used to determine a statistically significant difference.^{32, 33} Notably, van Rijn et al. (2017) highlight that "A common mistake is saying that $P < 0.05$ means that the null hypothesis is false, and $P \geq 0.05$ means that the null hypothesis is true. The correct interpretation of a P-value

of 0.05 is that if the null hypothesis were indeed true, a similar or more extreme result would occur 5% of the times upon repeating the study in a similar sample.”

With respect to this submission, clinical equivalence between dapagliflozin and placebo with respect to the incidence of UHFV events represents only one possible reason for the [redacted] treatment effect. One alternative reason is the [redacted].
[redacted]
[redacted].

Given these substantial imitations, the EAG’s interpretation that the [redacted] treatment effect should be equated to clinical equivalence lacks reasoning and should be considered with extreme caution.

This is particularly pertinent given the DELIVER trial design. The trial did meet is primary and secondary composites [redacted]. The statistical analyses of the trial and the target number of events were planned around ensuring sufficient statistical power for hypothesis testing of the primary endpoint, which was a composite endpoint of CV death, HHF or UHFV.²⁵ [redacted] in the occurrence of UHFV as a standalone endpoint, given that UHFV constitutes only one part of the overall composite endpoint of the DELIVER trial.²⁵ [redacted]
[redacted]
[redacted]
[redacted]
[redacted]
[redacted]
[redacted]
[redacted]
[redacted]
[redacted]

The forest plot presented in Figure 4 below demonstrates that all of the components of the primary composite endpoint [redacted] to the statistically significant treatment effect for the primary composite endpoint observed in DELIVER.⁹ Based on the UHFV HR of [redacted] (95% CI: [redacted], [redacted]) for dapagliflozin versus SoC, it seems reasonable to conclude that, given a sufficient number of events and follow-up, a statistically significant difference may have been observed between dapagliflozin and placebo with respect to UHFV.

Figure 4: Forest plot of the primary composite endpoint (CV mortality and HF events) and the individual components in DELIVER^a



Source: DELIVER CSR.⁹

Abbreviations: CI: confidence interval; CV: cardiovascular; Dapa: dapagliflozin; FAS: full analysis set; HF: heart failure; HHF: hospitalisation for heart failure; HR: hazard ratio; N: number of patients in treatment group; T2DM: type 2 diabetes mellitus; UHFV: urgent heart failure visit.

Regardless of the specific results observed from the DELIVER trial, the uncertainty regarding the [redacted] and underlying reason for this means that the most appropriate methodology for modelling UHFV should be the use of the DELIVER data directly, rather than assuming clinical equivalency.

This approach of using the trial data directly, [redacted], is aligned with TA679,¹⁰ and provides the most accurate representation of the incidence of UHFV for both dapagliflozin and placebo. Arbitrarily assuming clinical equivalence would also be in direct contrast to NICE's recommendations for their preferred sources of evidence: the NICE methods manual states that "for relative treatment effects there is a strong preference for high-quality randomised controlled trials (RCTs)", and "the trial should, in principle, provide a minimally biased estimate of the size of any benefits or risks associated with the technology relative to those associated with the comparator. RCTs are therefore considered to be most appropriate for measures of relative treatment effect." The use of the observed trial data directly is therefore aligned with this guidance.²²

The trial should, in principle, provide a minimally biased estimate of the size of any benefits or risks associated with the technology relative to those associated with the comparator. RCTs are therefore considered to be most appropriate for measures of relative treatment effect.

Finally, it is important to note that any uncertainty surrounding the treatment effect for UHFV is explicitly captured within the PSA conducted around the base case economic analysis. The PSA represents a much more robust methodology for evaluating the uncertainty regarding the

treatment effect for UHFV, versus arbitrarily removing the treatment effect altogether. The results of the PSA were closely aligned with the deterministic base case results, indicating that the model was robust to parameter uncertainty, such as the uncertainty relating to the UHFV treatment effect.

Considering the above, the Company has not conducted the EAG's requested scenario, given the substantial associated uncertainty and limitations.

B15. Priority question. [REDACTED]
[REDACTED] Please can the company provide the following scenarios:

- a) Removing the direct treatment effect of dapagliflozin in survival curve calculations for CV deaths;
- b) Removing the indirect treatment effect for CV deaths implicitly caused by the two treatments causing different KCCQ health state occupancy;
- c) A combined scenario of a and b.

For the reasons previously detailed in response to QB14, the Company does not consider this scenario analysis to be appropriate.

With respect to CV death specifically, Figure 1 presented in QB14 shows that all of the components of the primary composite endpoint [REDACTED] to the statistically significant treatment effect for the primary composite endpoint observed in DELIVER.⁹

Based on the CV death HR of [REDACTED] (95% CI: [REDACTED], [REDACTED]) for dapagliflozin versus SoC, it seems reasonable to conclude that, given a sufficient number of events, [REDACTED] would be observed between dapagliflozin and placebo with respect to CV death.

Considering this, the direct use of the CV-death data for dapagliflozin and placebo from the DELIVER trial is still considered to represent the most robust methodology for the base case economic analysis. Any uncertainty surrounding the treatment effect relating to CV-death has already been captured as part of the PSA, which indicated that the model is robust to parameter uncertainty.

Considering the above, and the substantial uncertainty and limitations that would be associated with scenarios assuming clinical equivalency, the Company does not consider that the EAG's requested scenarios are appropriate.

B16. Priority question. Given that [REDACTED] dapagliflozin [REDACTED] [REDACTED] non-CV death, please provide a scenario in the model where these events are excluded.

For the reasons previously detailed in response to QB14 and QB15, the Company does not consider this scenario analysis to be appropriate, and the use of the data from the DELIVER trial

to derive the rates of non-CV death for dapagliflozin and placebo represents a more robust methodology, compared to assuming clinical equivalency due to [REDACTED] difference with regard to treatment effect.

It should also be noted that the exclusion of non-CV deaths from the model, as suggested by the EAG, would introduce a substantial limitation, given the relatively high likelihood of non-CV death for a patient population with a starting age of [REDACTED] years⁹, which could bias the cost-effectiveness results between dapagliflozin and placebo and introduce additional uncertainty.

B17. Priority question. The company's base case using the Weibull distribution predicts that at 10 years in the analysis, approximately [REDACTED] of SoC patients are alive, while at 20 years in the model (when patients are approximately 92) there are still approximately [REDACTED] of SoC patients alive:

- a) Clinical expert opinion provided to the EAG suggests that while the Weibull distribution offers the most plausible extrapolation of all-cause mortality between the distributions, this is still an underestimation. Please run a scenario with an extrapolation which more closely reflects the life expectancy associated with pEF;**

As previously detailed in Document B, Section B.3.3.5, the selection of the Weibull curve as the most appropriate extrapolation for all-cause mortality was an extensive process, informed by statistical fit (the log-logistic, generalised gamma and Weibull distributions exhibited the lowest AIC and BIC for CV- and all-cause mortality), validation versus the published literature as well as clinical expert opinion. Notably, the EAG's clinical experts additionally agreed that the Weibull curve represents the most plausible extrapolation of mortality.

The adjusted all-cause mortality curves, presented in Figure 5 below, demonstrate that there are no alternative extrapolations to the Weibull curve that could be used to model increased all-cause mortality, which would remain clinically plausible. The only curve which models increased all-cause mortality versus the Weibull is the Gompertz. However, the Gompertz curve predicts that all SoC patients would have died after approximately 12 years (reflecting an average age of [REDACTED]); an extremely pessimistic estimate of survival which likely overestimates mortality for this patient population.

Figure 5: Adjusted survival model extrapolations for all-cause mortality^a

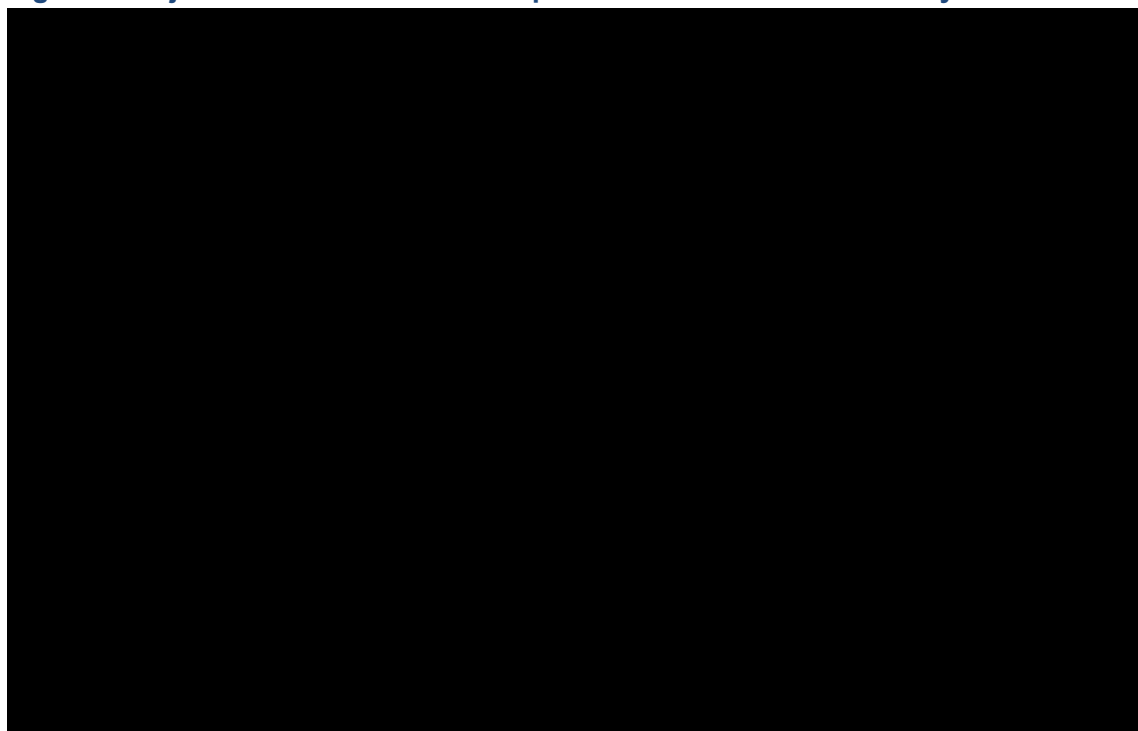

^aSurvival extrapolations are taken from the economic model to account for time-updated disease severity. Extrapolations include no application of general population mortality.

The highly pessimistic survival predicted by the Gompertz curve can be seen when compared versus Shahim *et al.* (2021), as previously described in Document B, Section B.3.3.5. Shahim *et al.* (2021) was a prospective, observational, multi-centre study which investigated long-term mortality outcomes in 397 patients with complete follow-up in the community setting in Sweden and France.³⁴ In this study, patients were enrolled after an acute HF event and had a mean baseline age of 78.³⁴

In order to inform the selection of the most appropriate extrapolation, the DELIVER individual patient trial data were re-weighted to align with the reported patient characteristics in Shahim *et al.* (2021), meaning that the two populations could be compared directly.³⁴ The re-weighted all-cause mortality KM curves and resulting extrapolations for the placebo arm in the DELIVER trial are presented in Figure 6 below, and compared with the reported survival predictions from Shahim *et al.* (2021).³⁴

As can be observed in Figure 24, the predicted survival using the Gompertz curve was very pessimistic compared with the 10-year estimate of survival from Shahim *et al.* (2021); whereas, the Weibull curve was aligned with the 10-year estimate of survival from Shahim *et al.* (2021).

Figure 6: Adjusted all-cause mortality predictions for patients receiving placebo in the DELIVER trial compared with long-term survival reported in Shahim *et al.* (2021)^{34a}



^aThe black dots relate to 1-, 3-, 5- and 10-year survival reported in Shahim *et al.* (2021). Survival model extrapolations are presented only for the placebo arm.

Finally, it should be noted that clinical expert opinion collected by the Company indicated that the Weibull and generalised gamma distributions could both be considered to provide reasonable estimates of survival, whereas the estimates of survival from the Gompertz extrapolation were too pessimistic.

The Gompertz curve, as well as all of the other extrapolations, have previously been considered as a scenario analysis for all-cause mortality as well as CV-mortality (Table 62 in Document B, and Table 31 in the Revised Base Case results section below), demonstrating that the use of alternative extrapolations for CV-mortality and all-cause mortality have a negligible impact on the final cost-effectiveness results. However, the use of the Gompertz curve should be considered with caution and is associated with substantial uncertainty, as it is associated with estimates of survival that are highly underestimated, and consequently, limited clinical plausibility.

In the absence of any alternative approaches, it has not been possible to provide any further scenarios in response to this question, however, for the reasons presented above, this use of the Weibull extrapolation should not be considered a major cause for uncertainty. Therefore the Weibull curve is the extrapolation that represents the most appropriate extrapolation for all-cause mortality.

b) Clinical expert opinion provided to the EAG was that the pEF population in the UK is on average 80 years at baseline and presents with considerable co-morbidities. Please run a scenario in the model where the baseline age for the UK population is reflected in terms of life expectancy in the long-term model.

As previously discussed with the EAG and NICE during the clarification call, a scenario analysis modelling an increased baseline age was included within the original company submission. As detailed in Document B, Section B.3.3.2, in this scenario analysis, a mean age of [REDACTED] years was modelled, based on the UK CPRD dataset.²⁰ The EAG agreed on the clarification call that the CPRD scenario is sufficient and a scenario with a mean age of 80 years is not warranted.

The results of this scenario analysis were previously provided in Document B and have been presented based on the revised base case in Table 25 below, indicating that the increased baseline age has a negligible impact on the ICER.

Full probabilistic and deterministic results for all scenarios can be found in Table 31 of the Revised Base Case results section.

Table 25: Scenario analysis using the UK CPRD dataset

Scenario Analysis Description	Deterministic Results		
	Inc. Costs	Inc. QALYs	ICER
Base case (following clarification questions)	£1,885	0.251	£7,519
Scenario 1 (using the UK CPRD dataset with a baseline age of [REDACTED] years)	£1,896	0.242	£7,847

Abbreviations: CPRD: clinical practice research datalink; ICER: incremental cost-effectiveness ratio; QALYs: quality-adjusted life years; UK: United Kingdom.

Source: UK CPRD dataset.²⁰

Scenario analysis

B18. Priority question. Please provide the deterministic results of the scenarios outlined in Table 62.

Updated probabilistic and deterministic results for the scenarios outlined in Document B, Table 62, which also include the correction to the Company base case previously detailed in Response to Question A13, are provided in the Revised Base Case Results, Table 25 at the end of this response document.

Please additionally note that the Company has identified an error for scenario 10 of the original company submission. Age-adjustments were incorrectly applied to health state utilities as well as transient and adverse events. This has been corrected to apply the adjustment to health state utilities only. This has now been corrected in the model submitted alongside these responses.

B19. Priority question. Please add colour coding to the parameter limits increasing and decreasing the ICER in the tornado diagram (Figure 28).

A revised tornado plot has been provided in Figure 7, where blue colouring represents the use of the upper parameter and purple colouring represents the use of the lower parameter.

Figure 7: Tornado plot of base case DSA results with colour coding to the parameter limits increasing and decreasing the ICER^a

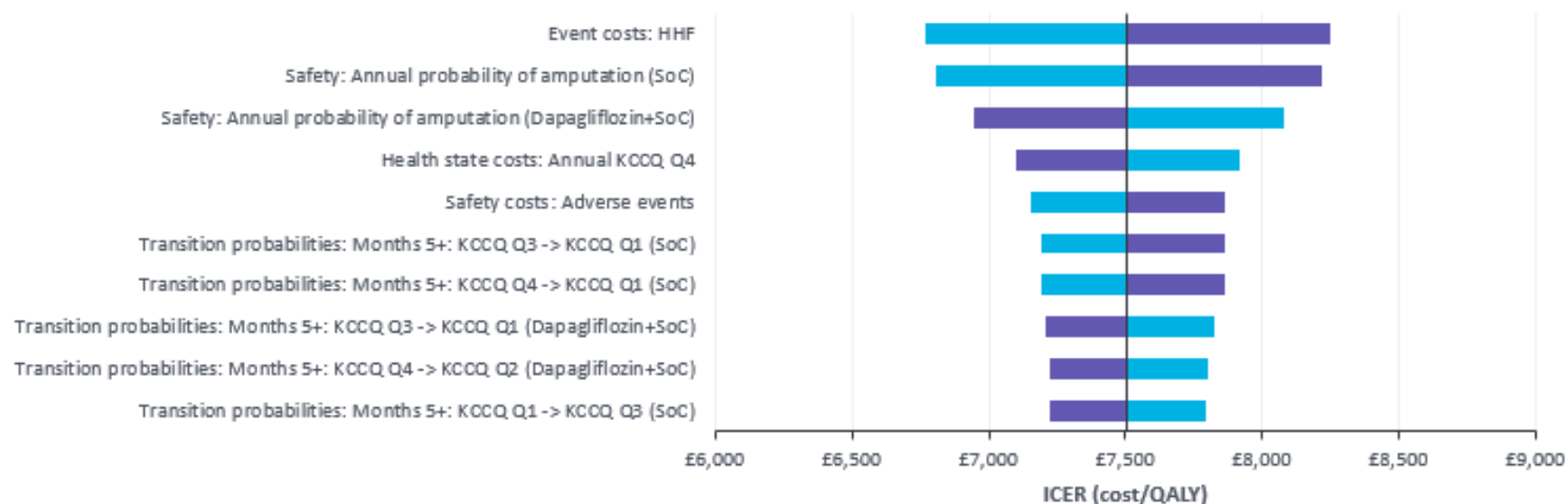

Footnotes: ^aBlue = upper parameter; purple = lower parameter.

Abbreviations: DSA: deterministic sensitivity analysis; HHF: hospitalisation for heart failure; ICER: incremental cost-effectiveness ratio; KCCQ-TSS: Kansas City Cardiomyopathy Questionnaire Total Symptom Score; SoC: standard of care; QALY: quality-adjusted life year.

B20. Priority question. Using the table below, please fill out the resulting incremental cost-effectiveness ratios (ICERs) of the scenarios outlined above in addition to a “combined” scenario which incorporates all of the changes outlined in all scenarios.

A summary of the EAG’s requested scenario analyses has been provided in Table 26, below. Please note that for continuity with the original submission, the scenarios presented in Table 62 have been numbered as Scenarios 1-13 throughout this response, and the new scenarios conducted as part of this response have been numbered from 14 onwards.

Please note that the EAG’s scenarios requested in this table in response to QB9, B14, B15, B16 and B17 have not been conducted for the reasons detailed in response to each of these questions.

Table 26: Summary of the EAG’s requested scenario analysis

Scenario	Related to clarification question	Changes from base case	Resulting ICER
14	B2	Excluded amputation from the cost effectiveness model.	£8,538
15	B3	Use the probability of adverse events as in TA679.	£8,435
16	B6	Cap the total annual number of GP visits per patient to 6.	£6,826
17	B7	Use non-elective long term and day cases NHS References 2019/20 costs inflated to the 20/21 cost year.	£8,161
18	B8	Use the NHS cost code EB03E to cost HHF events.	£8,466
20	B12a	Assume the disutility from a HHF event persists for 2.75 cycles of the model.	£7,372
21	B12b	Assume the disutility from a HHF event persists for 6 cycles of the model.	£7,114
22 (Scenario 14-21, excluding 20)	B2-B12b, excluding B12a	Combination of Scenario 14-21, excluding Scenario 20.	£8,210

Additional clarification questions

B21. On page 101 of the CS it states, “Mixed effects models were used to account for repeated measures and within-patient correlation adjusted for time from baseline, sex, KCCQ-TSS quartile, T2DM at baseline, body mass index, and age.” Can the company please:

- a) Explain how these covariates were chosen;

A variable selection algorithm was followed with the [REDACTED]

[REDACTED]

[REDACTED]

[REDACTED]

[REDACTED] The aim of this criterion was to limit the time that could pass between an event (HF or adverse) and the EQ-5D-5L measurement that would capture the effect of the event on health-related quality of life, and further by requiring a minimum count, to prevent the derivation of estimates from too few occurrences. When applied to the DELIVER trial data, only the HF events (HHF and UHFV) satisfied this criterion; adverse events were therefore excluded from the utility analysis since there were too few occurrences within the 31-day period to inform estimates.

[REDACTED]

[REDACTED]

[REDACTED]

[REDACTED]

[REDACTED]

[REDACTED]

[REDACTED]

[REDACTED]

[REDACTED]

[REDACTED]

[REDACTED]

[REDACTED]

[REDACTED]

[REDACTED]

[REDACTED]

[REDACTED]

[REDACTED]

[REDACTED]

- b) Provide the coefficients, standard errors, 95% confidence intervals and p values resulting from each covariate in the regression model;

The coefficients, standard errors, 95% confidence interval and p-values for each parameter included in the fixed effects model is presented in Table 27.

Table 27. Adjusted utility coefficients derived from the ITT DELIVER population (fixed effects)

Parameter	Coefficient	SE	95% CI	p-value
Intercept	[REDACTED]	[REDACTED]	[REDACTED]	[REDACTED]
Month	[REDACTED]	[REDACTED]	[REDACTED]	[REDACTED]
HHF	[REDACTED]	[REDACTED]	[REDACTED]	[REDACTED]
UHFV	[REDACTED]	[REDACTED]	[REDACTED]	[REDACTED]
Age	[REDACTED]	[REDACTED]	[REDACTED]	[REDACTED]
Male	[REDACTED]	[REDACTED]	[REDACTED]	[REDACTED]
BMI (kg/m ²)	[REDACTED]	[REDACTED]	[REDACTED]	[REDACTED]

[REDACTED]

[REDACTED]

B22. The company states that “transition probabilities between health states defined by KCCQ-TSS quartiles were derived using month transition count data from the DELIVER trial, assuming last observation carried forward”.

Please can the company outline what proportion of observations used to derive the transition probabilities were generated using the last observation carried forward approach?

In the DELIVER trial, there were [REDACTED] observations of KCCQ data for which the total symptom score could be calculated.³ As described in response A7, transition probabilities are not determined monthly, but represent an aggregate of disease progression change over the 0-4 month period and the period 4 months onwards for the separate treatment arms. Observations are not “generated” via LOCF since the data in months between the recording of new KCCQ-TSS measurements represent the last known state of the patient, reflective of clinical disease management.

For purposes of the model, to generate monthly transition probabilities, a KCCQ-TSS value is required at each month (using the described LOCF) in order not to bias the probability estimate towards when observations occurred. For each patient, a monthly interval framework is extended from baseline to the time of trial censoring or death; as a result, [REDACTED] monthly slots were defined, representing [REDACTED] occupancy of direct observations.

B23. Please can the company produce figures showing the adjusted survival model extrapolations for all-cause and CV mortality using a single statistical model instead of the piecewise approach.

Single survival models for mortality (all-cause or CV) were determined to be inappropriate for analysis according to the recommendations of NICE DSU TSD14, which were used to determine the most appropriate survival models in a robust and transparent manner.

Figure 8 is a reproduced version of the decision flowchart from NICE DSU TSD 14 which was used to inform modelling decisions in the DELIVER trial analysis, with the initial path highlighted in orange and further consideration in blue.

Figure 8: Reproduction of NICE DSU TSD14 Figure 3, Section 6.1, (model selection algorithm)

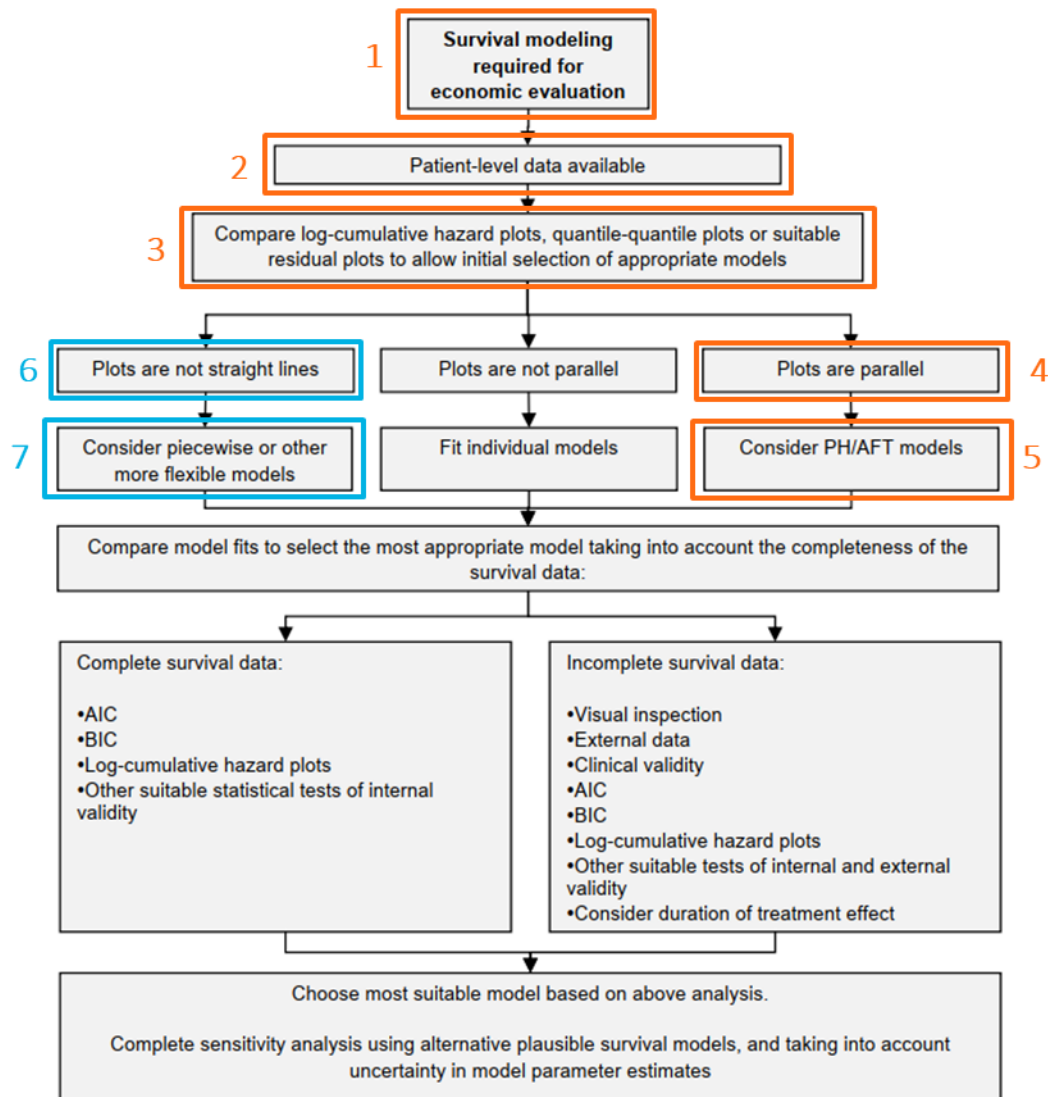

Based on this flowchart, the following decisions were made to determine the choice of the most appropriate models:

1. Survival modelling was deemed necessary to extrapolate results to a lifetime time horizon.
2. Individual patient data were available.
3. The listed plot types, including log cumulative hazard (LCH) plots, as well as scaled Schoenfeld residual plots were assessed to inform initial model assessment.
4. LCH plots were seen to be broadly parallel for stratification by treatment arm and many, but not all KCCQ-TSS-defined health states.
5. Parametric distributions would be appropriate to apply provided assumptions of proportional hazards (PH) or accelerated failure time (AFT) were satisfied.
6. Further consideration was required to assess the PH assumption, as some individual traces of the LCH plots may not have been straight lines.
7. A piecewise model with adjustment for time-varying covariate was evaluated and found appropriate to address non-proportionality of hazards.

The analysis began with a single survival model for which diagnostics were assessed. As examples, the LCH plots for ACM and CVM are shown below when data are stratified by treatment arm (Figure 9) and by health state (Figure 10). While the treatment arm results suggested [REDACTED] with the PH assumption, stratification by KCCQ-TSS-defined health state, where there may be evidence of some [REDACTED] among individual quartiles, suggested further investigation was warranted.

Figure 9: Log-cumulative hazards from the DELIVER trial according to treatment arm

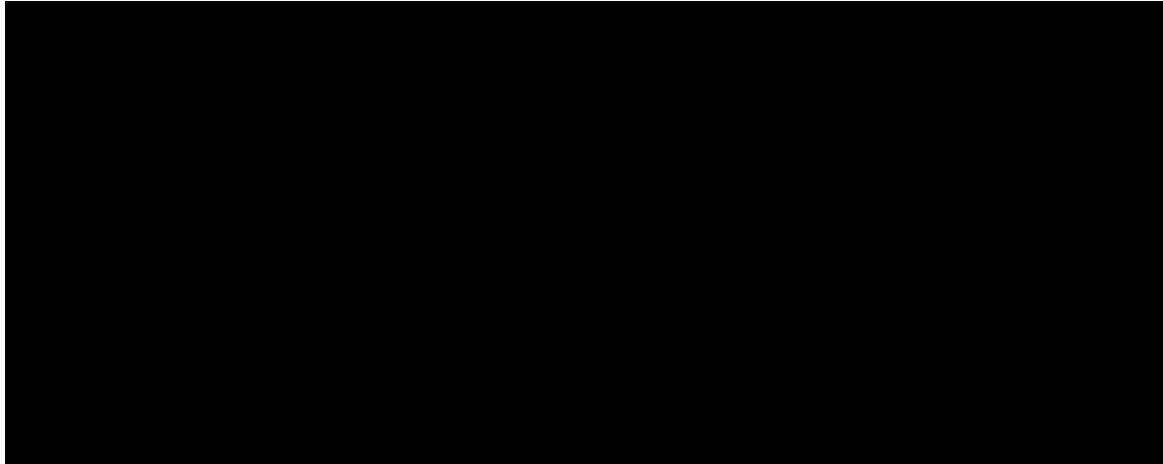

Abbreviations: ACM, all-cause mortality; CVM, cardiovascular mortality

Figure 10: Log-cumulative hazards from the DELIVER trial according to KCCQ-TSS defined health state

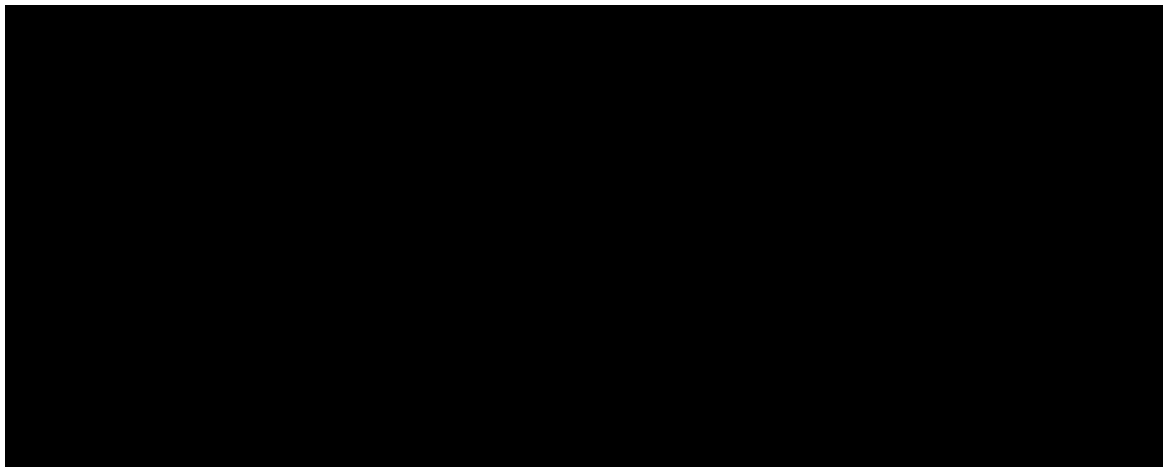

Abbreviations: ACM, all-cause mortality; CVM, cardiovascular mortality; Q1-Q4, Kansas city cardiomyopathy questionnaire, total symptom score quartiles [defining health states]

Close visual inspection of the LCH plots reveals that not all health state traces are likely to be straight lines, where, for example, [REDACTED]. This observation corresponds to the decision node at cell 6 of the model selection flow chart of Figure 8, informing consideration of piecewise models if lines are not straight. This assertion was confirmed using plots of scaled Schoenfeld residuals that allowed quantification of the potential PH violation (Figure 11).

Figure 11: Schoenfeld residual plots for single survival models from the DELIVER trial

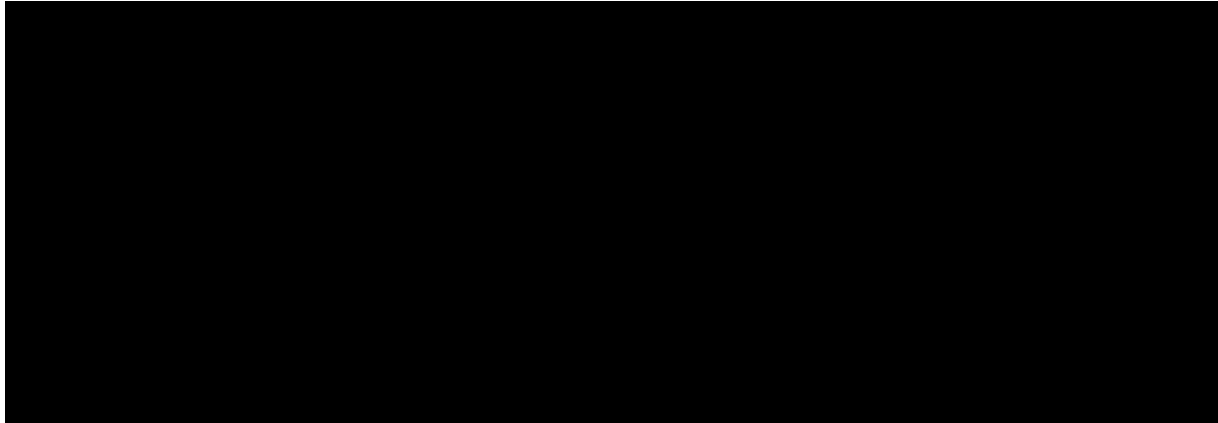

Abbreviations: ACM, all-cause mortality; CVM, cardiovascular mortality; Q1-Q4, Kansas city cardiomyopathy questionnaire, total symptom score quartiles [defining health states].

As seen, clear violations of the PH assumption (cases where p-values < 0.05 occurred) were observed [redacted]. Visual inspection revealed Q2 and Q3 [redacted]. Q1, in contrast, [redacted] this assumption over the duration of trial follow-up.

Application of an epoch parameter defined at 1 year of follow-up addressed this issue, as shown in Figure 12. When added to the intervalised survival data, the p-values were found to be consistent with use of the PH assumption. Note that since the application is for null hypothesis testing, p-values above an alpha of 0.05 cannot prove the validity of the PH assumption, but instead indicate that the applied transformation does not result in data suggestive of a violation of the PH assumption.

Figure 12: Schoenfeld residual plots for piecewise survival models from the DELIVER trial

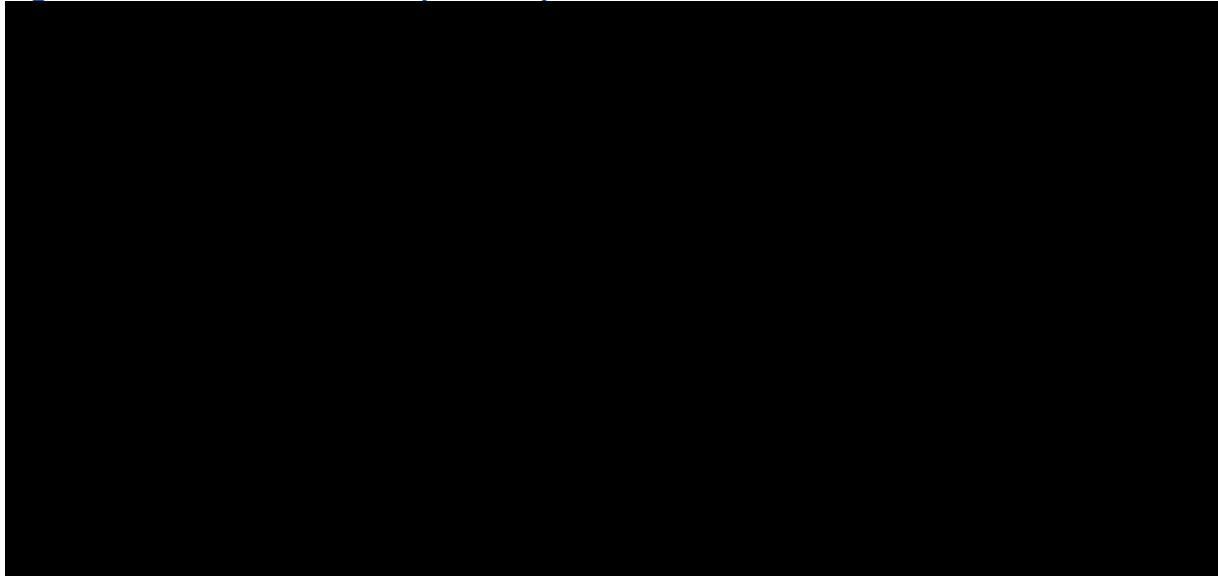

Abbreviations: ACM, all-cause mortality; CVM, cardiovascular mortality; EP1, epoch phase 1 (time ≤ 1 year); EP2, epoch phase 2 (time > 1 year); Q1-Q4, Kansas City cardiomyopathy questionnaire, total symptom score quartiles [defining health states]

It would therefore be inappropriate to model results using a single survival model without the application of an adjustment to address proportionality of hazards, here corrected using the piecewise approach from the NICE DSU TSD14 recommendations.

Section C: Textual clarification and additional points

No questions.

Revised Base Case Results

Base case incremental economic analysis results

As previously detailed in response to QA13, the Company has updated its base case to include a minor correction to the proportion of patients with an eGFR <60 mL/min/1.73m². The revised base case economic analysis results expressed in terms of incremental cost-effectiveness ratios (ICERs) and net monetary benefit (NMB) are presented in Table 28 and Table 29, respectively.

Table 28: Base case economic analysis results – ICERs

Technologies	Total costs (£)	Total LYG	Total QALYs	Incremental costs (£)	Incremental LYG	Incremental QALYs	ICER (£/QALY)
Dapagliflozin plus SoC	£14,352	8.295	5.052	£1,885	0.370	0.251	£7,519
SoC	£12,467	4.801	-	-	-	-	-

Abbreviations: ICER: incremental cost-effectiveness ratio; LYG: life years gained; QALY: quality-adjusted life year; SoC: standard of care.

Table 29: Base case economic analysis results – NMB

Technologies	Total costs (£)	Total QALYs	Incremental costs (£)	Incremental QALYs	NMB at £20,000/QALY	NMB at £30,000/QALY
Dapagliflozin plus SoC	£14,352	5.052	£1,885	0.251	£86,690	£137,211
SoC	£12,467	4.801	-	-	£83,562	£131,576

Abbreviations: ICER: incremental cost-effectiveness ratio; LYG: life years gained; NMB: net monetary benefit; QALYs: quality-adjusted life years; SoC: standard of care.

Probabilistic sensitivity analysis results

The results of the base case PSA are presented in Table 32 below, with the scatterplot and cost-effectiveness acceptability curves presented in Figure 13 and Figure 14, respectively. The results show that dapagliflozin in addition to SoC had a 90.7% and 93.7% probability of being cost-effective at a WTP thresholds of £20,000 and £30,000/QALY gained, respectively.

Table 30: Base case PSA results

Technologies	Total costs (£)	Total QALYs	Incremental costs (£)	Incremental QALYs	ICER incremental (£/QALY)
Dapagliflozin plus SoC	£14,315	4.974	£1,896	0.261	£7,276
SoC	£12,419	4.714	-	-	-

Abbreviations: ICER: incremental cost-effectiveness ratio; LYG: life years gained; PSA: probabilistic sensitivity analysis; QALYs: quality-adjusted life years; SoC: standard of care.

Figure 13: Cost-effectiveness scatter plot from PSA

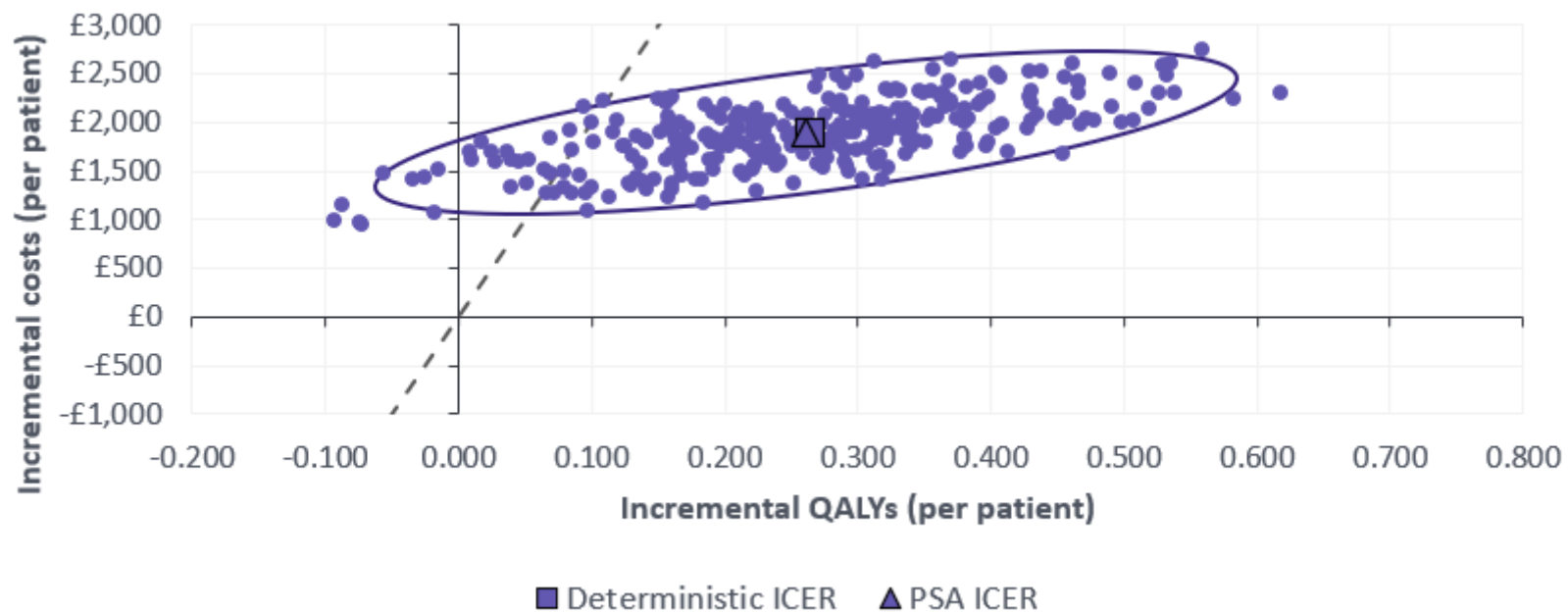

Abbreviations: ICER: incremental cost-effectiveness ratio; QALY: quality-adjusted life year; PSA: probabilistic sensitivity analysis.

Figure 14: Cost-effectiveness acceptability curve from PSA

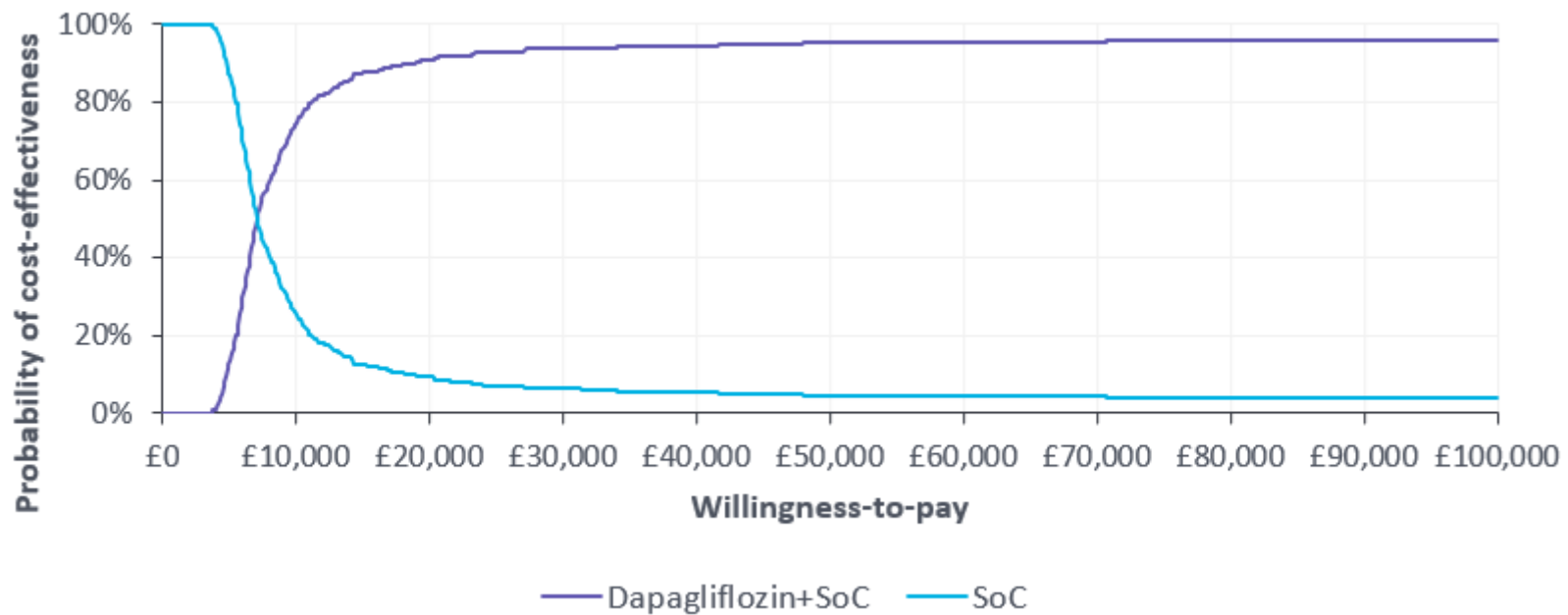

Abbreviations: PSA: probabilistic sensitivity analysis; SoC: standard of care.

Figure 15: ICER convergence plot from PSA

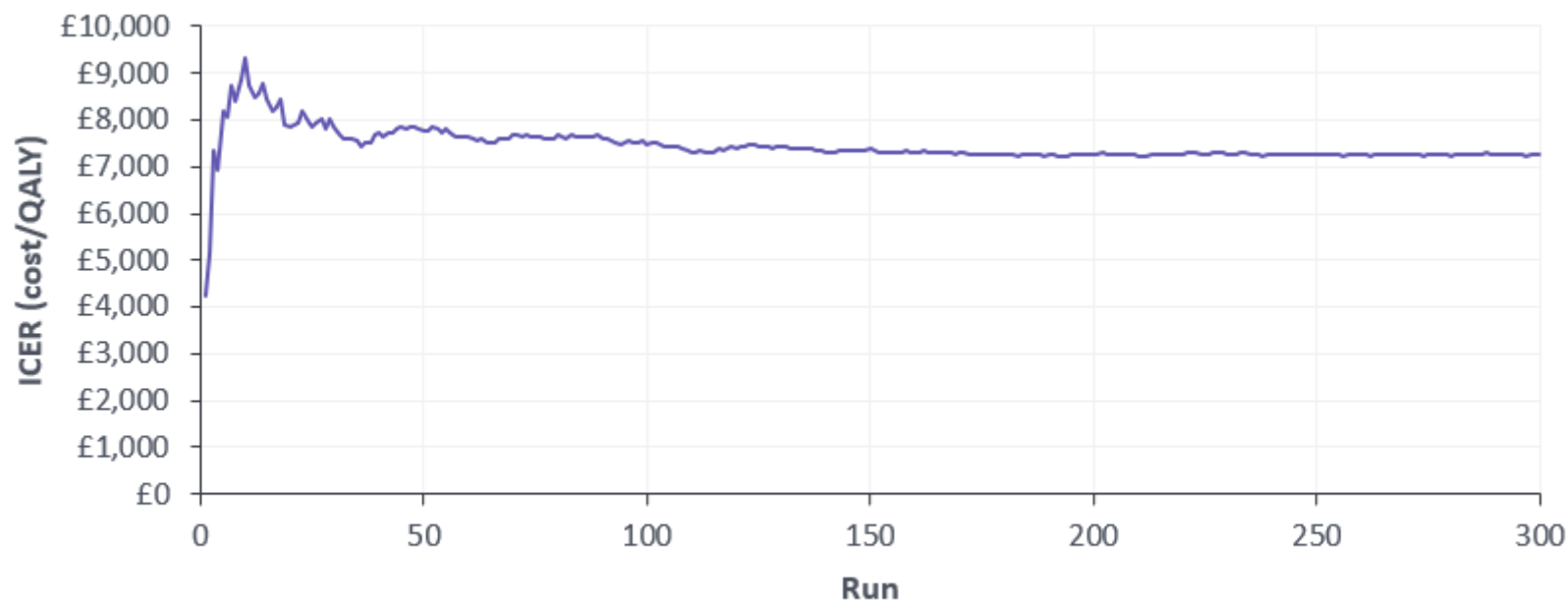

Abbreviations: ICER: incremental cost-effectiveness ratio; PSA: probabilistic sensitivity analysis.

Deterministic Sensitivity Analyses

The results of the DSA are summarised in Figure 16 below; the most influential factors on the DSA were the annual probability of amputation in the SoC and dapagliflozin in addition to SoC arms, and the event cost of HHF. However, the DSA showed that none of the included parameters had a substantial impact on the ICER, with all ICERs remaining below £9,000/QALY gained across the DSA scenarios.

Figure 16: Tornado plot of DSA results^a

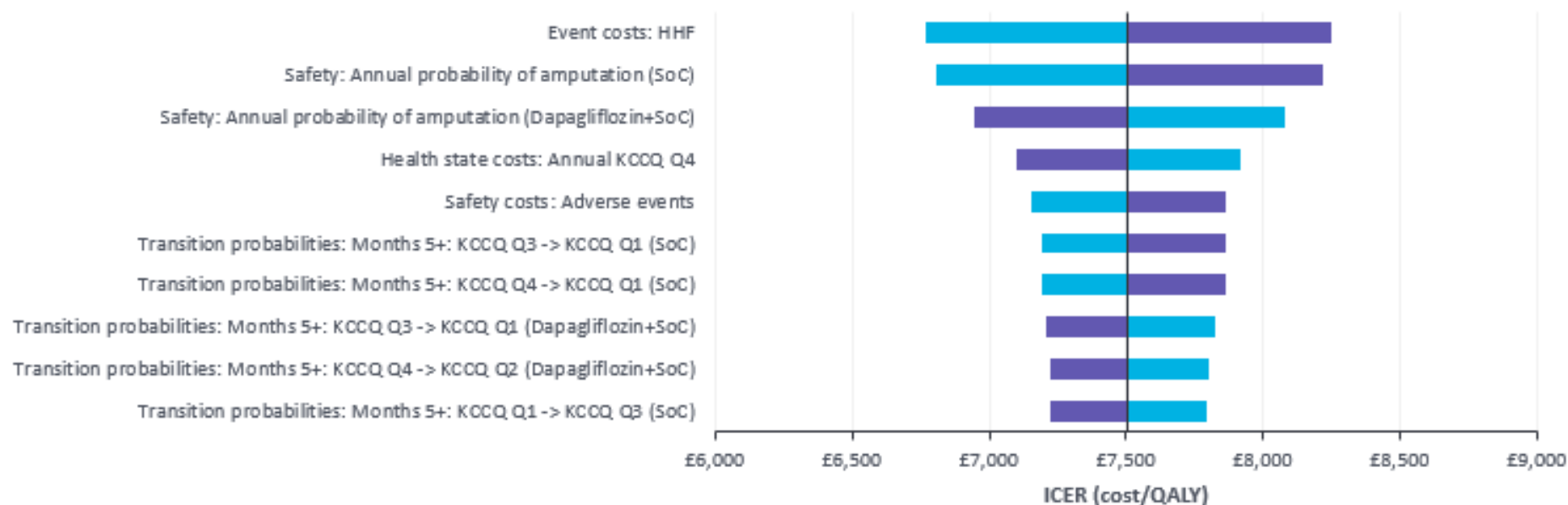

^aBlue = upper ICER; purple = lower ICER.

Abbreviations: DSA: deterministic sensitivity analysis; HHF: hospitalisation for heart failure; ICER: incremental cost-effectiveness ratio; KCCQ-TSS: Kansas City Cardiomyopathy Questionnaire Total Symptom Score; SoC: standard of care; QALY: quality-adjusted life year.

Scenario analysis results

A range of scenario analyses were conducted to test the robustness of the model to alternative model inputs and assumptions. Each scenario was run with 300 probabilistic iterations as in the base case PSA, and also run deterministically. All of the scenarios supported the robustness of the base case ICER, with no scenarios associated with ICERs higher than £12,000/QALY gained. A description of each scenario analysis, as well as the probabilistic and deterministic results of each scenario, are presented in Table 31.

Table 31: Summary of scenario analyses

#	Scenario analysis description	Scenario analysis details	Probabilistic results (for dapagliflozin plus SoC)			Deterministic results (for dapagliflozin plus SoC)		
			Incr. costs	Incr. QALYs	ICER	Incr. costs	Incr. QALYs	ICER
1	Baseline characteristics.	Baseline characteristics were derived from UK CPRD ²⁰ for patients with HF and an LVEF >40%, as detailed in Document B, Section B.3.3.2. The UK CPRD provides baseline characteristics reflective of patients with HF and an LVEF >40% in UK clinical practice; characterising any uncertainty relating to the generalisability of the DELIVER trial to UK clinical practice. ²¹	£1,906	0.237	£8,025	£1,896	0.242	£7,847
2	Risk equations used to model HF events (HHF and UHFV).	This scenario analysis used unadjusted risk equations for HF events, including only treatment as a covariate, were utilised, as detailed in Section B.3.3.7.	£1,895	0.247	£7,681	£1,883	0.251	£7,513
3	Risk equations used to model mortality.	Unadjusted Weibull distributions including only treatment as a covariate were utilised for CV and all-cause mortality, as detailed in Section B.3.3.5.	£1,772	0.189	£9,399	£1,750	0.187	£9,362
4	Parametric distributions for both CV-mortality and all-cause mortality.	The exponential distribution was used to model both CV-mortality and all-cause mortality.	£2,169	0.294	£7,369	£2,129	0.290	£7,345
5		The log-normal distribution was used to model both CV-mortality and all-cause mortality.	£2,050	0.216	£9,502	£2,023	0.219	£9,234
6		The log-logistic distribution was used to model both CV-mortality and all-cause mortality.	£1,984	0.235	£8,456	£1,964	0.238	£8,265
7		The Gompertz distribution was used to model both CV-mortality and all-cause mortality.	£1,477	0.155	£9,501	£1,460	0.152	£9,590

#	Scenario analysis description	Scenario analysis details	Probabilistic results (for dapagliflozin plus SoC)			Deterministic results (for dapagliflozin plus SoC)		
			Incr. costs	Incr. QALYs	ICER	Incr. costs	Incr. QALYs	ICER
8		The Generalised gamma distribution was used to model both CV-mortality and all-cause mortality.	£1,961	0.248	£7,899	£1,943	0.252	£7,702
9	General population mortality.	Survival estimates were not bounded by general population mortality to explore the impact of the approach taken in the base case economic analysis.	£1,900	0.249	£7,644	£1,888	0.252	£7,482
10	Utilities.	Health state utility values were also age-adjusted over the model time horizon using UK population norm values for EQ-5D as reported in the 2014 dataset by the NICE DSU. ³⁵	£1,896	0.234	£8,088	£1,885	0.238	£7,913
11	Cost of non-CV mortality.	The cost of non-CV mortality was set equal to CV mortality.	£1,852	0.247	£7,511	£1,844	0.251	£7,356
12	Adverse events.	It was assumed that no AEs were associated with SoC.	£2,754	0.227	£12,156	£2,768	0.232	£11,943
13	Utilities.	The health state utility for KCCQ-TSS Q4 was assumed to be equal to general population utility; the relative decrements between KCCQ-TSS Q1–Q3 and Q4 based on the DELIVER trial data were applied to the general population utility to derive the health state utility values for KCCQ-TSS Q1–Q3. The following KCCQ-TSS health state utilities were therefore used in the scenario: <ul style="list-style-type: none"> • KCCQ-TSS Q1: <u>0.513</u> (SE: <u>0.103</u>); • KCCQ-TSS Q2: <u>0.631</u> (SE: <u>0.126</u>); • KCCQ-TSS Q3: <u>0.713</u> (SE: <u>0.143</u>); • KCCQ-TSS Q4: <u>0.793</u> (SE: <u>0.159</u>). 	£1,896	0.233	£8,151	£1,885	0.237	£7,955
14	B2	Excluded amputation from the cost effectiveness model.	£2,102	0.241	£8,737	£2,109	0.247	£8,538

#	Scenario analysis description	Scenario analysis details	Probabilistic results (for dapagliflozin plus SoC)			Deterministic results (for dapagliflozin plus SoC)		
			Incr. costs	Incr. QALYs	ICER	Incr. costs	Incr. QALYs	ICER
15	B3	Use the probability of adverse events as in TA679.	£2,080	0.240	£8,656	£2,077	0.246	£8,435
16	B6	Cap the total annual number of GP visits per patient to 6.	£1,727	0.247	£7,001	£1,711	0.251	£6,826
17	B7	Use non-elective long term and day cases NHS References 2019/20 costs inflated to the 20/21 cost year.	£2,059	0.247	£8,348	£2,046	0.251	£8,161
18	B8	Use the NHS cost code EB03E to cost HHF events.	£2,136	0.247	£8,659	£2,122	0.251	£8,466
19	B12a	Assume the disutility from a HHF event persists for 2.75 cycles of the model.	£1,896	0.252	£7,538	£1,885	0.256	£7,372
20	B12b	Assume the disutility from a HHF event persists for 6 cycles of the model.	£1,896	0.261	£7,276	£1,885	0.265	£7,114

Abbreviations: AE: adverse event; CPRD: Clinical Practice Research Datalink; CV: cardiovascular; DSU: Decision Support Unit; EQ-5D: EuroQoL-5 Dimensions; GP: general practitioner; HF: heart failure; HHF: hospitalisation for heart failure; ICER: incremental cost-effectiveness ratio; KCCQ-TSS: Kansas City Cardiomyopathy Questionnaire – Total Symptom Score; LVEF: left ventricular ejection fraction; NHS: National Health Service; NICE: National Institute for Health and Care Excellence; QALY: quality-adjusted life year; SE: standard error; SoC: standard of care; UHFV: urgent heart failure visit; UK: United Kingdom.

References

1. Solomon SD, McMurray JJV, Claggett B, et al. Dapagliflozin in Heart Failure with Mildly Reduced or Preserved Ejection Fraction. *N Engl J Med* 2022.
2. National Institute for Health and Care Excellence (NICE). Pirfenidone for treating idiopathic pulmonary fibrosis [TA504]. Available at: <https://www.nice.org.uk/guidance/ta504> [accessed 27 October 2022]. 2018.
3. AstraZeneca UK Ltd. AstraZeneca Data on File.
4. Jhund PS, Kondo T, Butt JH, et al. Dapagliflozin across the range of ejection fraction in patients with heart failure: a patient-level, pooled meta-analysis of DAPA-HF and DELIVER. *Nat Med* 2022.
5. AstraZeneca UK Ltd. Data on File. ID: REF-161426 [Draft Manuscript. Dapagliflozin in Heart Failure with Improved Ejection Fraction (Vardeny et al. 2022)]. 2022.
6. National Institute for Health and Care Excellence (NICE). Chronic heart failure in adults: diagnosis and management [NG106]. Available at: <https://www.nice.org.uk/guidance/ng106> [accessed 20 April 2022]. 2018.
7. Selvaraj S, Vaduganathan M, Claggett BL, et al. Blood Pressure and Dapagliflozin in Heart Failure with Mildly Reduced or Preserved Ejection Fraction: DELIVER. *JACC: Heart Failure* 2022.
8. Adamson C, Kondo T, Jhund P, et al. Dapagliflozin for heart failure according to body mass index: the DELIVER trial. *European Heart Journal* 2022.
9. AstraZeneca. Data on File. Clinical Study Report. An international, double-blind, randomised, placebo-controlled phase III study to evaluate the effect of dapagliflozin on reducing cardiovascular death or worsening heart failure in patients with heart failure with preserved Ejection Fraction (HFpEF): DELIVER - Dapagliflozin Evaluation to Improve the LIVEs of Patients with PReserved Ejection Fraction Heart Failure . 2022.
10. National Institute for Health and Care Excellence (NICE). Dapagliflozin for treating chronic heart failure with reduced ejection fraction [TA679]. Available at: <https://www.nice.org.uk/guidance/ta679> [accessed 28 April 2022]. 2021.
11. AstraZeneca. AstraZeneca Data on File. DELIVER Study Protocol.
12. McMurray JJV, Solomon SD, Inzucchi SE, et al. Dapagliflozin in Patients with Heart Failure and Reduced Ejection Fraction. *N Engl J Med* 2019;381:1995-2008.
13. Anker SD, Butler J, Filippatos G, et al. Empagliflozin in Heart Failure with a Preserved Ejection Fraction. *N Engl J Med* 2021;385:1451-1461.
14. Packer M, Anker SD, Butler J, et al. Effect of empagliflozin on the clinical stability of patients with heart failure and a reduced ejection fraction: the EMPEROR-Reduced trial. *Circulation* 2021;143:326-336.
15. McMurray JJV, Packer M, Desai AS, et al. Angiotensin–Neprilysin Inhibition versus Enalapril in Heart Failure. *New England Journal of Medicine* 2014;371:993-1004.

16. Solomon SD, McMurray JJV, Anand IS, et al. Angiotensin-Neprilysin Inhibition in Heart Failure with Preserved Ejection Fraction. *New England Journal of Medicine* 2019;381:1609-1620.
17. AstraZeneca UK Ltd. Data on File. ID: REF-161435 [The effects of dapagliflozin on symptoms, function and quality of life in patients with heart failure and mildly reduced or preserved ejection fraction: results from the DELIVER Trial]. 2022.
18. McEwan P, Darlington O, McMurray JJV, et al. Cost-effectiveness of dapagliflozin as a treatment for heart failure with reduced ejection fraction: a multinational health-economic analysis of DAPA-HF. *Eur J Heart Fail* 2020;22:2147-2156.
19. Neal B, Perkovic V, Mahaffey KW, et al. Canagliflozin and cardiovascular and renal events in type 2 diabetes. *New England Journal of Medicine* 2017;377:644-657.
20. AstraZeneca UK Ltd. Data on File. ID: REF-155912 [UK Clinical Practice Research Datalink (CPRD)]. 2022.
21. AstraZeneca UK Ltd. Data on File. ID: REF-151249 [Summary of clinician interviews to support the NICE HTA submission for HFpEF]. 2022.
22. National Institute for Health and Care Excellence (NICE). NICE health technology evaluations: the manual. Process and methods [PMG36]. Available at: <https://www.nice.org.uk/process/pmg36/> [accessed 08 September 2022]. 2022.
23. U.S. Food and Drug Administration (FDA). Public Workshop on Patient-Focused Drug Development: Guidance 4 – Incorporating Clinical Outcome Assessments into Endpoints for Regulatory Decision Making. Available at: <https://www.fda.gov/drugs/development-approval-process-drugs/public-workshop-patient-focused-drug-development-guidance-4-incorporating-clinical-outcome> [accessed 28 October 2022], 2019.
24. AstraZeneca UK Ltd. Data on File. ID: REF-156527 [Loop diuretic standard care in HFpEF/mrEF in England]. 2022.
25. Solomon SD, de Boer RA, DeMets D, et al. Dapagliflozin in heart failure with preserved and mildly reduced ejection fraction: rationale and design of the DELIVER trial. *European journal of heart failure* 2021;23:1217-1225.
26. Electronic Medicines Compendium (EMC). Furosemide 40mg Tablets. Summary of Product Characteristics (SmPC). Available at: <https://www.medicines.org.uk/emc/product/6012/smpc> [accessed 12 August 2022].
27. Electronic Medicines Compendium (EMC). Bumetanide 1 mg Tablets. Summary of Product Characteristics (SmPC). Available at: <https://www.medicines.org.uk/emc/product/2542/smpc> [accessed 12 August 2022].
28. AstraZeneca UK Ltd. AstraZeneca Data on File. Guidance for Global and Local Study Teams Regarding Clinical Study Protocol Changes and Protocol Deviations During the 2019-Novel Corona Virus Outbreak (COVID-19).
29. National Institute for Health and Care Excellence (NICE). Dapagliflozin for treating chronic heart failure with reduced ejection fraction [TA679]. Available at: <https://www.nice.org.uk/guidance/ta679> [last accessed 28 April 2022]. 2021.
30. McMurray JJV, Trueman D, Hancock E, et al. Cost-effectiveness of sacubitril/valsartan in the treatment of heart failure with reduced ejection fraction. *Heart* 2018;104:1006-1013.

31. Personal Social Services Research Unit. Unit Costs of Health and Social Care 2021. Available at: <https://kar.kent.ac.uk/92342/19/Unit%20Costs%20Report%202021%20-%20Final%20version%20for%20publication.pdf> [accessed 14 July 2022] 2020.
32. Wasserstein RL, Lazar NA. The ASA statement on p-values: context, process, and purpose. Volume 70: Taylor & Francis, 2016:129-133.
33. van Rijn MHC, Bech A, Bouyer J, et al. Statistical significance versus clinical relevance. Nephrology Dialysis Transplantation 2017;32:ii6-ii12.
34. Shahim A, Hourqueig M, Donal E, et al. Predictors of long-term outcome in heart failure with preserved ejection fraction: a follow-up from the KaRen study. ESC Heart Fail 2021;8:4243-4254.
35. Hernández Alava M et al. NICE DSU. Estimating EQ-5D by age and sex for the UK. Available at: <https://nicedsu.sites.sheffield.ac.uk/methods-development/estimating-eq-5d-by-age-and-sex-for-the-uk>. [accessed 10 May 2022]. 2022.

Appendix

Table 32: Analysis of change from baseline in KCCQ-TSS at 8 months (FAS)

Treatment group	Baseline					Change from baseline				Difference between Dapagliflozin 10 mg and Placebo		
	N# ^a	n ^b	Missing n (%) ^c	Mean	SD	n ^b	Missing n (%) ^c	Mean	SD	Mean difference	95% CI	p-value
Dapa 10 mg	■	■	■	■	■	■	■	■	■	■	■	■
Placebo	■	■	■	■	■	■	■	■	■			

Footnotes: ^aN# is the number of patients alive in study at 8 months. ^bn is the number of patients with non-missing value at baseline and with change from baseline at 8 months respectively. ^cThe denominator for the proportion of missing data is N#.

The difference in change from baseline between treatment groups is analysed in a repeated measures model with terms for treatment group, baseline TSS score, visit and visit by treatment group interaction.

Abbreviations: CI: confidence interval; Dapa: Dapagliflozin; FAS: Full analysis set; SD: standard deviation; TSS: Total symptom score.

Table 33: Analysis of change from baseline in KCCQ-TSS at 8 months - pre-pandemic population (FAS)

Treatment group	Baseline					Change from baseline				Difference between Dapagliflozin 10 mg and Placebo		
	N# ^a	n ^b	Missing n (%) ^c	Mean	SD	n ^b	Missing n (%) ^c	Mean	SD	Mean difference	95% CI	p-value
Dapa 10 mg	■	■	■	■	■	■	■	■	■	■	■	■
Placebo	■	■	■	■	■	■	■	■	■			

Footnotes: ^aN# is the number of patients alive in study at 8 months. ^bn is the number of patients with non-missing value at baseline and with change from baseline at 8 months respectively. ^cThe denominator for the proportion of missing data is N#.

Including patients with a 8-month assessment (Visit 5) planned or performed prior to 11 March 2020, when COVID-19 was declared a pandemic by the WHO.

The difference in change from baseline between treatment groups is analysed in a repeated measures model with terms for treatment group, baseline TSS score, visit and visit by treatment group interaction.

Abbreviations: CI: confidence interval; Dapa: Dapagliflozin; FAS: Full analysis set; SD: standard deviation; TSS: Total symptom score.

Table 34: Analysis of change from baseline in KCCQ-TSS at 8 months by subgroups (FAS)

			Baseline				Change from baseline				Difference between Dapagliflozin 10 mg and Placebo			
Patient characteristic Category	Treatment group	N# ^a	n ^b	Missing n (%) ^c	Mean	SD	n ^b	Missing n (%) ^c	Mean	SD	Mean difference	95% CI	p-value	Interaction p-value
History of T2DM														
Yes	Dapa 10 mg	■	■	■	■	■	■	■	■	■	■	■	■	■
	Placebo	■	■	■	■	■	■	■	■	■	■	■		
No	Dapa 10 mg	■	■	■	■	■	■	■	■	■	■	■		
	Placebo	■	■	■	■	■	■	■	■	■	■	■		
LVEF at baseline														
≤ 49	Dapa 10 mg	■	■	■	■	■	■	■	■	■	■	■	■	
	Placebo	■	■	■	■	■	■	■	■	■	■	■		
50-59	Dapa 10 mg	■	■	■	■	■	■	■	■	■	■	■		
	Placebo	■	■	■	■	■	■	■	■	■	■	■		
≥ 60	Dapa 10 mg	■	■	■	■	■	■	■	■	■	■	■		
	Placebo	■	■	■	■	■	■	■	■	■	■	■		
Prior LVEF ≤ 40%														
Yes	Dapa 10 mg	■	■	■	■	■	■	■	■	■	■	■	■	
	Placebo	■	■	■	■	■	■	■	■	■	■	■		
No	Dapa 10 mg	■	■	■	■	■	■	■	■	■	■	■		
	Placebo	■	■	■	■	■	■	■	■	■	■	■		

Footnotes: ^aN# is the number of patients alive in study at 8 months. ^bn is the number of patients with non-missing value at baseline and with change from baseline at 8 months respectively. ^cThe denominator for the proportion of missing data is N#.

The difference in change from baseline between treatment groups is analysed in a linear model with baseline and treatment group as factors, and when calculating the interaction p-value also including factor for subgroup variable and subgroup by treatment interaction, baseline TSS score, visit and visit by treatment group interaction.

Abbreviations: CI: confidence interval; Dapa: Dapagliflozin; FAS: Full analysis set; SD: standard deviation; TSS: Total symptom score.

Table 35: Responder analysis of KCCQ -TSS at 8 months (FAS)

Threshold	Dapagliflozin 10 mg (N=1316)		Placebo (N=1311)		Odds ratio	95% CI	p-value
	n	n ^a (%) meeting threshold	n	n ^a (%) meeting threshold			
≥ 5 points improvement	█	██████████	█	██████████	█	██████████	█
≥ 10 points improvement	█	██████████	█	██████████	█	██████████	█
≥ 15 points improvement	█	██████████	█	██████████	█	██████████	█
≥ 5 points deterioration	█	██████████	█	██████████	█	██████████	█

Footnotes: ^a Number of patients who had an observed improvement/deterioration from baseline equal to or exceeding the given threshold.

Odds ratios are obtained from logistic regression with treatment group in the model.

Odds ratio > 1 favors Dapa 10 mg for improvement. Odds ratio < 1 favors Dapa 10 mg for deterioration.

Abbreviations: CI: Confidence interval; Dapa: Dapagliflozin; FAS: Full analysis set; KCCQ: Kansas City Cardiomyopathy Questionnaire; N: Number of patients in treatment group; n: Number of patients with observed data; TSS: Total Symptom Score.

Table 36: Responder analysis of KCCQ -TSS at 8 months - pre-pandemic population (FAS)

	Dapagliflozin 10 mg (N=1316)		Placebo (N=1311)		Odds ratio	95% CI	p-value
Threshold	n	n ^a (%) meeting threshold	n	n ^a (%) meeting threshold			
≥ 5 points improvement	█	██████████	█	██████████	█	██████████	█
≥ 10 points improvement	█	██████████	█	██████████	█	██████████	█
≥ 15 points improvement	█	██████████	█	██████████	█	██████████	█
≥ 5 points deterioration	█	██████████	█	██████████	█	██████████	█

Footnotes: ^a Number of patients who had an observed improvement/deterioration from baseline equal to or exceeding the given threshold.

Odds ratios are obtained from logistic regression with treatment group in the model.

Odds ratio > 1 favors Dapa 10 mg for improvement. Odds ratio < 1 favors Dapa 10 mg for deterioration.

Including patients with a 8-month assessment (Visit 5) planned or performed prior to 11 March 2020, when COVID-19 was declared a pandemic by the WHO.

Abbreviations: CI: Confidence interval; Dapa: Dapagliflozin; FAS: Full analysis set; KCCQ: Kansas City Cardiomyopathy Questionnaire; N: Number of patients in treatment group; n: Number of patients with observed data; TSS: Total Symptom Score.

Table 37: Responder analysis of KCCQ -TSS at 8 months by subgroups (FAS)

Threshold	Patient characteristic category	Dapagliflozin 10 mg (N=1316)		Placebo (N=1311)		Odds ratio	95% CI	p-value	Interaction p-value
		n	n ^a (%) meeting threshold	n	n ^a (%) meeting threshold				
≥ 5 points improvement	History of T2DM								
	Yes	■	■	■	■	■	■	■	■
	No	■	■	■	■	■	■	■	
	LVEF at baseline								
	≤ 49	■	■	■	■	■	■	■	■
	50-59	■	■	■	■	■	■	■	
	≥ 60	■	■	■	■	■	■	■	
	Prior LVEF ≤ 40%								
	Yes	■	■	■	■	■	■	■	■
	No	■	■	■	■	■	■	■	
≥ 10 points improvement	History of T2DM								
	Yes	■	■	■	■	■	■	■	■
	No	■	■	■	■	■	■	■	
	LVEF at baseline								
	≤ 49	■	■	■	■	■	■	■	■
	50-59	■	■	■	■	■	■	■	
	≥ 60	■	■	■	■	■	■	■	
	Prior LVEF ≤ 40%								
	Yes	■	■	■	■	■	■	■	■
	No	■	■	■	■	■	■	■	
≥ 15 points improvement	History of T2DM								
	Yes	■	■	■	■	■	■	■	■
	No	■	■	■	■	■	■	■	

Threshold	Patient characteristic category	Dapagliflozin 10 mg (N=1316)		Placebo (N=1311)		Odds ratio	95% CI	p-value	Interaction p-value
		n	n ^a (%) meeting threshold	n	n ^a (%) meeting threshold				
	LVEF at baseline								
	≤ 49	■	■	■	■	■	■	■	■
	50-59	■	■	■	■	■	■		
	≥ 60	■	■	■	■	■	■		
	Prior LVEF ≤ 40%								
	Yes	■	■	■	■	■	■	■	■
No	■	■	■	■	■	■	■		
≥ 5 points deterioration	History of T2DM								
	Yes	■	■	■	■	■	■	■	■
	No	■	■	■	■	■	■	■	
	LVEF at baseline								
	≤ 49	■	■	■	■	■	■	■	■
	50-59	■	■	■	■	■	■		
	≥ 60	■	■	■	■	■	■		
	Prior LVEF ≤ 40%								
	Yes	■	■	■	■	■	■	■	■
	No	■	■	■	■	■	■	■	

Footnotes: ^a Number of patients who had an observed improvement/deterioration from baseline equal to or exceeding the given threshold. Odds ratios are obtained from logistic regression with treatment group in the model, and when calculating the interaction p-value also including factor for subgroup variable and subgroup by treatment interaction. Odds ratio > 1 favors Dapa 10 mg for improvement. Odds ratio < 1 favors Dapa 10 mg for deterioration.

Abbreviations: CI: Confidence interval; Dapa: Dapagliflozin; FAS: Full analysis set; KCCQ: Kansas City Cardiomyopathy Questionnaire; N: Number of patients in treatment group; n: Number of patients with observed data; TSS: Total Symptom Score.

Single Technology Appraisal

Dapagliflozin for treating chronic heart failure with preserved or mildly reduced ejection fraction [ID1648]

Professional organisation submission

Thank you for agreeing to give us your organisation's views on this technology and its possible use in the NHS.

You can provide a unique perspective on the technology in the context of current clinical practice that is not typically available from the published literature.

To help you give your views, please use this questionnaire. You do not have to answer every question – they are prompts to guide you. The text boxes will expand as you type.

Information on completing this submission

- Please do not embed documents (such as a PDF) in a submission because this may lead to the information being mislaid or make the submission unreadable
- We are committed to meeting the requirements of copyright legislation. If you intend to include **journal articles** in your submission you must have copyright clearance for these articles. We can accept journal articles in NICE Docs.
- Your response should not be longer than 13 pages.

About you

1. Your name	[REDACTED]
2. Name of organisation	UK Clinical Pharmacy Association – Heart Failure Committee
3. Job title or position	[REDACTED] [REDACTED]
4. Are you (please select Yes or No):	An employee or representative of a healthcare professional organisation that represents clinicians? Yes A specialist in the treatment of people with this condition? Yes A specialist in the clinical evidence base for this condition or technology? Yes Other (please specify):
5a. Brief description of the organisation (including who funds it).	A membership organisation for pharmacy professionals, funded by membership fees
5b. Has the organisation received any funding from the manufacturer(s) of the technology and/or comparator products in the last 12 months? [Relevant manufacturers are listed in the appraisal stakeholder list.] If so, please state the name of manufacturer, amount, and purpose of funding.	[Could not find appraisal matrix.]
5c. Do you have any direct or indirect links with, or funding from, the tobacco industry?	No.

The aim of treatment for this condition

<p>6. What is the main aim of treatment? (For example, to stop progression, to improve mobility, to cure the condition, or prevent progression or disability.)</p>	<p>Heart failure is chronic, progressive condition associated with significant exercise limitation, impaired quality of life, high rates of unplanned hospitalisation and mortality rates comparable to most common forms of cancer.</p> <p>The main aims of heart failure treatment are to prevent disease progression, prevent hospital admission and reduce mortality. Improving quality of life by relieving symptoms is also an important aim.</p>
<p>7. What do you consider a clinically significant treatment response? (For example, a reduction in tumour size by x cm, or a reduction in disease activity by a certain amount.)</p>	<p>Clinically significant treatment responses include statistically significant improvements in hospitalisation, mortality and quality of life endpoints.</p>
<p>8. In your view, is there an unmet need for patients and healthcare professionals in this condition?</p>	<p>Yes.</p> <p>Heart failure is a leading cause of hospitalisation and death. HFpEF accounts for half of all patients diagnosed with heart failure and is a growing concern due to increasing incidence and no therapeutic treatment options to improve prognosis. Even once diagnosed, access to specialist care can be limited. We, the UKCPA, firmly believe there are significant unmet needs for patients with heart failure especially within the HFpEF diagnosis. These unmet needs include high mortality rates, high rates of unplanned hospitalisations and impaired quality of life.</p>

What is the expected place of the technology in current practice?

<p>9. How is the condition currently treated in the NHS?</p>	<p>This appraisal considers two different heart failure phenotypes:</p> <p>HFmrEF (EF 41-49%) – No substantial RCT has been performed exclusively in HFmrEF. Some of the pharmacological treatment options for patients with HFrEF <i>may</i> be considered for this cohort of patients (European Society of Cardiology Guidelines, 2021). This includes ACE inhibitors/Angiotensin II receptor blockers/neprilysin inhibitors, beta-blockers and mineralocorticoid receptor antagonists.</p> <p>HFpEF (EF > 50%) – Treatment is focussed on managing patient comorbidities such as atrial fibrillation, diabetes, hypertension, kidney disease. Weight loss in obese patients and increasing exercise may improve symptoms and exercise capacity.</p> <p>Diuretics are provided to patients with <u>all</u> types of heart failure to reduce congestion.</p> <p>There is no evidence to advise non-pharmacological treatment (CRT or ICD therapy) in patients with HFmrEF or HFpEF.</p>
<p>9a. Are any clinical guidelines used in the treatment of the condition, and if so, which?</p>	<p>2018 NICE Chronic heart failure in adults: diagnosis and management NICE Guideline 106</p> <p>2021 ESC Guidelines for the diagnosis and treatment of acute and chronic heart failure <i>European Heart Journal</i>, Volume 42, Issue 36, 21 September 2021, Pages 3599–3726 https://doi.org/10.1093/eurheartj/ehab368</p>
<p>9b. Is the pathway of care well defined? Does it vary or are there differences of opinion between professionals across the NHS? (Please state if your experience is from outside England.)</p>	<p>Diagnostic and treatment pathways for patients with or suspected of having heart failure are well defined in published guidelines (as above) although there are regional/local variations in access to diagnostic tests and interpretation/implementation of some elements of the guidelines.</p> <p>The terminology of HFpEF is not widely understood by professionals out with a heart failure specialism. To date treatment option have been limited to symptomatic management. Many heart failure specialist services only see patients with HFrEF, therefore, increasing numbers of patients with HFpEF poses a large burden to the NHS and particularly primary care, who may be managing these patients independently.</p>

<p>9c. What impact would the technology have on the current pathway of care?</p>	<p>The technology will provide a treatment option for patients where there is little or no evidence for any pharmacological treatment other than symptomatic relief.</p> <p>It may increase awareness of HFpEF as more patients will be eligible for treatment.</p> <p>The technology might encourage commissioners to extend the scope of current heart failure services and provide more standardised pathways of care.</p>
<p>10. Will the technology be used (or is it already used) in the same way as current care in NHS clinical practice?</p>	<p>Dapagliflozin is not currently licenced for use in HFpEF but is licenced for this use in HFrEF and approved by NICE. Dapagliflozin will be used in HFpEF the same way as for HFrEF in line with current care in NHS clinical practice.</p>
<p>10a. How does healthcare resource use differ between the technology and current care?</p>	
<p>10b. In what clinical setting should the technology be used? (For example, primary or secondary care, specialist clinics.)</p>	<p>Dapagliflozin is a sodium-glucose transporter-2 inhibitor (SGLT2i) currently licenced for use in type 2 diabetes mellitus (T2DM) and is well established in primary and secondary care services across the UK. We envisage that Dapagliflozin in HFpEF will be used on the recommendation of a heart failure specialist but could be commenced in primary and secondary care services as it is already well-established in these arena for other purposes.</p>
<p>10c. What investment is needed to introduce the technology? (For example, for facilities, equipment, or training.)</p>	<p>This technology is already used in the management of type 2 diabetes, and also licensed for HFrEF and chronic kidney disease. Little additional investment is required to introduce Dapagliflozin into clinical practice for patients with HFpEF. Additional visits to HF specialist teams may also be required although since Dapagliflozin requires no dose titration, these visits will represent a small increase to the visits already required. In patients with concomitant T2DM, collaboration with diabetes specialist teams may be necessary and additional training for HF specialists in the management of T2DM glucose-lowering agents.</p>
<p>11. Do you expect the technology to provide clinically meaningful benefits compared with current care?</p>	<p>The DELIVER clinical trial clearly demonstrates that, compared to placebo, Dapagliflozin significantly reduces hospitalisation for HF and improves quality of life.</p> <p>These are all clinically meaningful end-points for patients with HF and Dapagliflozin is expected to provide significant benefit to these patients.</p>

<p>11a. Do you expect the technology to increase length of life more than current care?</p>	<p>The DELIVER clinical trial met its primary end point, a composite end point of heart failure hospitalisation and CV death. Further systematic reviews of the combined clinical trials of SGLT2 inhibitors in heart failure have been shown to reduced mortality rates.</p>
<p>11b. Do you expect the technology to increase health-related quality of life more than current care?</p>	<p>The DELIVER clinical trial used the KCCQ questionnaire to look at HRQoL, there was a statistically significant difference between treatment and placebo arms.</p>
<p>12. Are there any groups of people for whom the technology would be more or less effective (or appropriate) than the general population?</p>	<p>The technology also has evidence for use in patients with type 2 diabetes and chronic kidney disease; these patients would benefit from this.</p>

The use of the technology

<p>13. Will the technology be easier or more difficult to use for patients or healthcare professionals than current care? Are there any practical implications for its use (for example, any concomitant treatments needed, additional clinical requirements, factors affecting patient acceptability or ease of use or additional tests or monitoring needed.)</p>	<p>SGLT2i are already well established in current clinical care for use in patients with HFrEF and T2DM. Therefore, transition into patients with HFpEF is expected to be uncomplicated for healthcare professionals. Monitoring for most patients will be in line with usual care for patients with HFrEF although patients with HFpEF and T2DM may require adjustment of other glucose lowering medications</p>
--	---

<p>14. Will any rules (informal or formal) be used to start or stop treatment with the technology? Do these include any additional testing?</p>	<p>Patients with HFpEF are likely to be selected for treatment with Dapagliflozin based on current diagnostic pathways that already include NT-proBNP, renal function and echocardiography. Additional testing is not expected for most patients with HFpEF. Patients with concomitant T2DM may require a period of additional glucose monitoring to guide adjustments to other glucose-lowering medications. The treatment will be ongoing indefinitely once initiated. The treatment would only be stopped if the patient developed significant side effects.</p>
<p>15. Do you consider that the use of the technology will result in any substantial health-related benefits that are unlikely to be included in the quality-adjusted life year (QALY) calculation?</p>	<p>No</p>
<p>16. Do you consider the technology to be innovative in its potential to make a significant and substantial impact on health-related benefits and how might it improve the way that current need is met?</p>	<p>Dapagliflozin joins a number of other SGLT2i's in demonstrating significant outcome benefits in patients with heart failure, but there has been no prior evidence for HFpEF. Therefore, whilst the use of SGLT2 inhibitors in heart failure may not be innovative, this new indication of HFpEF is. It maintains potential to provide significant health benefits in patients with HFpEF by creating a therapeutic option and may improve access to HF specialists.</p>
<p>16a. Is the technology a 'step-change' in the management of the condition?</p>	<p>The DELIVER study shows significant benefits of SGLT2i's in patients with HFpEF and the SGLT2i class represents a new and the only prognostic treatment for HFpEF.</p>

16b. Does the use of the technology address any particular unmet need of the patient population?	Dapagliflozin improves morbidity, mortality and quality of life in patients with HFpEF thereby addressing the areas of unmet need already described.
17. How do any side effects or adverse effects of the technology affect the management of the condition and the patient's quality of life?	<p>Dapagliflozin was well tolerated in the DELIVER trial with serious adverse events (43.5% vs 45.5%, respectively). The only excess side-effect noted compared to placebo was volume depletion.</p> <p>Patients should be advised of possible side effects when the medication is started so they know to seek medical attention should they develop any. They should also be counselled on “sick-day rules” and to withhold the medication if acutely unwell and at risk of dehydration e.g vomiting, diarrhoea, to reduce the risk of DKA. This is routine practice when SGLT-2 inhibitors are used for other licensed indications.</p>

Sources of evidence

18. Do the clinical trials on the technology reflect current UK clinical practice?	The DELIVER trial does reflect currently clinical practice; in terms of baseline patient characteristics, baseline therapies and currently treatment process.
18a. If not, how could the results be extrapolated to the UK setting?	
18b. What, in your view, are the most important outcomes, and were they measured in the trials?	The DELIVER trial has all addressed the major outcomes relevant to unmet needs in HF management including; unplanned hospitalisation, mortality and symptoms/quality of life.
18c. If surrogate outcome measures were used, do they adequately predict	

long-term clinical outcomes?	
18d. Are there any adverse effects that were not apparent in clinical trials but have come to light subsequently?	
19. Are you aware of any relevant evidence that might not be found by a systematic review of the trial evidence?	None
20. How do data on real-world experience compare with the trial data?	We are not aware of any currently published data on real-world use of Dapagliflozin in HFpEF as it is yet to be licenced for this use.

Equality

21a. Are there any potential equality issues that should be taken into account when considering this treatment?	No
21b. Consider whether these issues are different from issues with current care and why.	No

Key messages

<p>22. In up to 5 bullet points, please summarise the key messages of your submission.</p>	<ul style="list-style-type: none">• Prevalence of HFpEF are increasing in the UK, and represent a large proportion of heart failure admissions to hospital• There are currently no pharmacological treatment options shown to reduce hospital admission, prolong life and improve quality of life for these patients• This technology is the largest RCT in HFpEF to reach its primary end-point showing a reduction in CV death• This technology will make a real and meaningful difference to NHS care for patients with HFpEF• Addition of recommending SGLT-2 inhibitors in the use of HFpEF patients to the NICE guidelines would increase clinician knowledge and confidence to prescribe this treatment
---	--

Thank you for your time.

Please log in to your NICE Docs account to upload your completed submission.

Your privacy

The information that you provide on this form will be used to contact you about the topic above.

Please select YES if you would like to receive information about other NICE topics - YES or NO

For more information about how we process your personal data please see our [privacy notice](#).

Single Technology Appraisal

Dapagliflozin for treating chronic heart failure with preserved or mildly reduced ejection fraction [ID1648]

Patient expert statement

Thank you for agreeing to give us your views on this treatment and its possible use in the NHS.

Your comments and feedback on the key issues below are really valued. You can provide a unique perspective on conditions and their treatment that is not typically available from other sources. The external assessment report (EAR) and stakeholder responses are used by the committee to help it make decisions at the committee meeting. Usually, only unresolved or uncertain key issues will be discussed at the meeting.

Information on completing this form

In [part 1](#) we are asking you about living with chronic heart failure with preserved or mildly reduced ejection fraction or caring for a patient with chronic heart failure with preserved or mildly reduced ejection fraction. The text boxes will expand as you type.

In [part 2](#) we are asking you to provide 5 summary sentences on the main points contained in this document.

Help with completing this form

If you have any questions or need help with completing this form please email the public involvement (PIP) team at pip@nice.org.uk (please include the ID number of your appraisal in any correspondence to the PIP team).

Please use this questionnaire with our [hints and tips for patient experts](#). You can also refer to the [Patient Organisation submission guide](#). **You do not have to answer every question** – they are prompts to guide you. There is also an opportunity to raise issues that are important to patients that you think have been missed and want to bring to the attention of the committee.

Please do not embed documents (such as a PDF) in a submission because this may lead to the information being mislaid or make the submission unreadable. Please type information directly into the form.

We are committed to meeting the requirements of copyright legislation. If you want to include **journal articles** in your submission you must have copyright clearance for these articles. We can accept journal articles in NICE Docs. For copyright reasons, we will have to return forms that have attachments without reading them. You can resubmit your form without attachments, but it must be sent by the deadline.

Your response should not be longer than 15 pages.

The deadline for your response is **5pm on Wednesday 16 November** Please log in to your NICE Docs account to upload your completed form, as a Word document (not a PDF).

Thank you for your time.

We reserve the right to summarise and edit comments received during engagement, or not to publish them at all, if we consider the comments are too long, or publication would be unlawful or otherwise inappropriate.

Comments received during engagement are published in the interests of openness and transparency, and to promote understanding of how recommendations are developed. The comments are published as a record of the comments we received, and are not endorsed by NICE, its officers or advisory committees.

Part 1: Living with this condition or caring for a patient with chronic heart failure with preserved or mildly reduced ejection fraction

Table 1 About you, chronic heart failure with preserved or mildly reduced ejection fraction, current treatments and equality

1. Your name	
2. Are you (please tick all that apply)	<input checked="" type="checkbox"/> A patient with chronic heart failure with preserved or mildly reduced ejection fraction? <input type="checkbox"/> A patient with experience of the treatment being evaluated? <input type="checkbox"/> A carer of a patient with chronic heart failure with preserved or mildly reduced ejection fraction? <input type="checkbox"/> A patient organisation employee or volunteer? <input type="checkbox"/> Other (please specify):
3. Name of your nominating organisation	
4. Has your nominating organisation provided a submission? (please tick all options that apply)	<input type="checkbox"/> No (please review all the questions and provide answers when possible) <input checked="" type="checkbox"/> Yes, my nominating organisation has provided a submission <input type="checkbox"/> I agree with it and do not wish to complete a patient expert statement <input type="checkbox"/> Yes, I authored / was a contributor to my nominating organisations submission <input type="checkbox"/> I agree with it and do not wish to complete this statement <input type="checkbox"/> I agree with it and will be completing
5. How did you gather the information included in your statement? (please tick all that apply)	<input checked="" type="checkbox"/> I am drawing from personal experience

	<p><input checked="" type="checkbox"/> I have other relevant knowledge or experience (for example, I am drawing on others' experiences). Please specify what other experience:</p> <p><input type="checkbox"/> I have completed part 2 of the statement after attending the expert engagement teleconference</p> <p><input type="checkbox"/> I have completed part 2 of the statement but was not able to attend the expert engagement teleconference</p> <p><input type="checkbox"/> I have not completed part 2 of the statement</p>
<p>6. What is your experience of living with chronic heart failure with preserved or mildly reduced ejection fraction?</p> <p>If you are a carer (for someone with chronic heart failure with preserved or mildly reduced ejection fraction) please share your experience of caring for them</p>	<p>I am a heart failure patient with HFrEF but am also a patient advocate or Pumping Marvellous & talk daily to other HF patients, some who are HFpEF.</p>
<p>7a. What do you think of the current treatments and care available for chronic heart failure with preserved or mildly reduced ejection fraction on the NHS?</p> <p>7b. How do your views on these current treatments compare to those of other people that you may be aware of?</p>	<p>I think more research needs to be done as there is very little medication available fir patients with HFpEF</p> <p>I speak for our community of patients when I say we all believe more treatments need to be available fir HFpEF patients,</p>
<p>8. If there are disadvantages for patients of current NHS treatments for chronic heart failure with preserved or mildly reduced ejection fraction (for example, how they are given or taken, side effects of treatment, and any others) please describe these</p>	<p>I don't think there are enough treatments available for HFpEF patients so it would be difficult to comment on their side effects.</p>
<p>9a. If there are advantages of dapagliflozin over current treatments on the NHS please describe these. For example, the effect on your quality of life, your ability to continue work, education, self-care, and care for others?</p>	<p>The advantages fir patients with HFrEF are huge. We hear of people with improvements to both QOL & heart function regularly. The same cannot be said yet fir those with HFpEF.</p>

<p>9b. If you have stated more than one advantage, which one(s) do you consider to be the most important, and why?</p> <p>9c. Does dapagliflozin help to overcome or address any of the listed disadvantages of current treatment that you have described in question 8? If so, please describe these</p>	
<p>10. If there are disadvantages of dapagliflozin over current treatments on the NHS please describe these.</p> <p>For example, are there any risks with dapagliflozin? If you are concerned about any potential side effects you have heard about, please describe them and explain why</p>	<p>The only disadvantage is the drop on blood pressure which some cannot tolerate.</p>
<p>11. Are there any groups of patients who might benefit more from dapagliflozin or any who may benefit less? If so, please describe them and explain why</p> <p>Consider, for example, if patients also have other health conditions (for example difficulties with mobility, dexterity or cognitive impairments) that affect the suitability of different treatments</p>	<p>The lack of medication fir this class of patients means that any medication is a positive here,</p>
<p>12. Are there any potential equality issues that should be taken into account when considering chronic heart failure with preserved or mildly reduced ejection fraction and dapagliflozin? Please explain if you think any groups of people with this condition are particularly disadvantaged</p> <p>Equality legislation includes people of a particular age, disability, gender reassignment, marriage and civil partnership, pregnancy and maternity, race, religion or belief, sex, and sexual orientation or people with any other shared characteristics</p>	<p>The lack of medication choices for these patients, the lack of relevant research & the prescribing issues. (See below).</p>

<p>More information on how NICE deals with equalities issues can be found in the NICE equality scheme Find more general information about the Equality Act and equalities issues here.</p>	
<p>13. Are there any other issues that you would like the committee to consider?</p>	<p>Equality, it would be wonderful if these medications could be prescribed by primary care practitioners, in the same way they are for diabetic patients.</p>

Part 2: Key messages

In up to 5 sentences, please summarise the key messages of your statement:

- Click or tap here to enter text.
- Click or tap here to enter text.
- Click or tap here to enter text.
- Click or tap here to enter text.
- Click or tap here to enter text.

Thank you for your time.

Your privacy

The information that you provide on this form will be used to contact you about the topic above.

Please tick this box if you would like to receive information about other NICE topics.

For more information about how we process your personal data please see [NICE's privacy notice](#).

Single Technology Appraisal

Dapagliflozin for treating chronic heart failure with preserved or mildly reduced ejection fraction [ID1648]

Patient expert statement

Thank you for agreeing to give us your views on this treatment and its possible use in the NHS.

Your comments and feedback on the key issues below are really valued. You can provide a unique perspective on conditions and their treatment that is not typically available from other sources. The external assessment report (EAR) and stakeholder responses are used by the committee to help it make decisions at the committee meeting. Usually, only unresolved or uncertain key issues will be discussed at the meeting.

Information on completing this form

In [part 1](#) we are asking you about living with chronic heart failure with preserved or mildly reduced ejection fraction or caring for a patient with chronic heart failure with preserved or mildly reduced ejection fraction. The text boxes will expand as you type.

In [part 2](#) we are asking you to provide 5 summary sentences on the main points contained in this document.

Help with completing this form

If you have any questions or need help with completing this form please email the public involvement (PIP) team at pip@nice.org.uk (please include the ID number of your appraisal in any correspondence to the PIP team).

Please use this questionnaire with our [hints and tips for patient experts](#). You can also refer to the [Patient Organisation submission guide](#). **You do not have to answer every question** – they are prompts to guide you. There is also an opportunity to raise issues that are important to patients that you think have been missed and want to bring to the attention of the committee.

Please do not embed documents (such as a PDF) in a submission because this may lead to the information being mislaid or make the submission unreadable. Please type information directly into the form.

We are committed to meeting the requirements of copyright legislation. If you want to include **journal articles** in your submission you must have copyright clearance for these articles. We can accept journal articles in NICE Docs. For copyright reasons, we will have to return forms that have attachments without reading them. You can resubmit your form without attachments, but it must be sent by the deadline.

Your response should not be longer than 15 pages.

The deadline for your response is **5pm on Friday 28 October**. Please log in to your NICE Docs account to upload your completed form, as a Word document (not a PDF).

Thank you for your time.

We reserve the right to summarise and edit comments received during engagement, or not to publish them at all, if we consider the comments are too long, or publication would be unlawful or otherwise inappropriate.

Comments received during engagement are published in the interests of openness and transparency, and to promote understanding of how recommendations are developed. The comments are published as a record of the comments we received, and are not endorsed by NICE, its officers or advisory committees.

Part 1: Living with this condition or caring for a patient with chronic heart failure with preserved or mildly reduced ejection fraction

Table 1 About you, chronic heart failure with preserved or mildly reduced ejection fraction, current treatments and equality

1. Your name	Nick Hartshorne-Evans
2. Are you (please tick all that apply)	<input type="checkbox"/> A patient with chronic heart failure with preserved or mildly reduced ejection fraction? <input checked="" type="checkbox"/> A patient with experience of the treatment being evaluated? <input type="checkbox"/> A carer of a patient with chronic heart failure with preserved or mildly reduced ejection fraction? <input checked="" type="checkbox"/> A patient organisation employee or volunteer? <input type="checkbox"/> Other (please specify):
3. Name of your nominating organisation	Pumping Marvellous Foundation
4. Has your nominating organisation provided a submission? (please tick all options that apply)	<input checked="" type="checkbox"/> No (please review all the questions and provide answers when possible) <input type="checkbox"/> Yes, my nominating organisation has provided a submission <input type="checkbox"/> I agree with it and do not wish to complete a patient expert statement <input type="checkbox"/> Yes, I authored / was a contributor to my nominating organisations submission <input type="checkbox"/> I agree with it and do not wish to complete this statement <input type="checkbox"/> I agree with it and will be completing
5. How did you gather the information included in your statement? (please tick all that apply)	<input checked="" type="checkbox"/> I am drawing from personal experience

	<p><input checked="" type="checkbox"/> I have other relevant knowledge or experience (for example, I am drawing on others' experiences). Please specify what other experience:</p> <p><input type="checkbox"/> I have completed part 2 of the statement after attending the expert engagement teleconference</p> <p><input type="checkbox"/> I have completed part 2 of the statement but was not able to attend the expert engagement teleconference</p> <p><input checked="" type="checkbox"/> I have not completed part 2 of the statement</p>
<p>6. What is your experience of living with chronic heart failure with preserved or mildly reduced ejection fraction?</p> <p>If you are a carer (for someone with chronic heart failure with preserved or mildly reduced ejection fraction) please share your experience of caring for them</p>	<p>I was diagnosed with Heart Failure in 2010 and have lived with it since. I am a recovered heart failure patient with reduced ejection fraction. I am however the Founder and CEO of the Pumping Marvellous Foundation, and we represent patients with all types of heart failure across our communities and the UK. The signs, symptoms, and disease burden of all types of heart failure are very similar. There is a system, treatment and care access and equity difference between HFrEF and HFmrEF and HFpEF.</p>
<p>7a. What do you think of the current treatments and care available for chronic heart failure with preserved or mildly reduced ejection fraction on the NHS?</p> <p>7b. How do your views on these current treatments compare to those of other people that you may be aware of?</p>	<p>There are no guidelines or prognostically available treatments for people living with chronic HFpEF in the NHS. This is unacceptable and demonstrates the largest unmet need for patients living with heart failure. If the prevalence of HFpEF in the total UK population of all heart failure is 40% of 920,000 (2018 figures NICE) then there are just under 400,000 people in the UK at a severe disadvantage.</p>
<p>8. If there are disadvantages for patients of current NHS treatments for chronic heart failure with preserved or mildly reduced ejection fraction (for example, how they are given or taken, side effects of treatment, and any others) please describe these</p>	<p>There are no prognostically beneficial treatments for HFpEF patients</p> <p>There are no guidelines for HFpEF patients</p> <p>HFpEF patients access to Heart Failure Nurses and specialist MDT services is patchy at best.</p> <p>Commissioners of services do not commission services for HFpEF patients because of the lack of an evidence base in favour of HFrEF patients.</p> <p>HFpEF patients in the main are prescribed a diuretic for symptom relief and referred into Primary Care. Primary Care is not geared to treating or optimising patients with</p>

	<p>HFpEF. Many patients feel as though they are just left to wallow with nobody understanding how to help them.</p> <p>The patient cohort for HFpEF is significant. If this was happening in Cancer there would be National outrage.</p>
<p>9a. If there are advantages of dapagliflozin over current treatments on the NHS please describe these. For example, the effect on your quality of life, your ability to continue work, education, self-care, and care for others?</p> <p>9b. If you have stated more than one advantage, which one(s) do you consider to be the most important, and why?</p> <p>9c. Does dapagliflozin help to overcome or address any of the listed disadvantages of current treatment that you have described in question 8? If so, please describe these</p>	<p>There are no current treatments available to HFpEF patients in the NHS therefore across the most important endpoints that matter to patients there are benefits over the placebo arm of optimised patients.</p> <p>Mortality – There was a mortality benefit (pooled data from DAPA HF and Deliver Trials)</p> <p>Hospital readmission – There was a reduction in hospital readmissions (trial data DELIVER)</p> <p>Quality of Life – There was a statistically relevant benefit over the placebo arm when measured by KCCQ health questionnaire.</p> <p>Each one of the endpoints are equally important to the variety of individual stakeholders. For the patient, quality of life is very important and has equal standing to Mortality. The overriding advantage is that there are now treatments for people with HFpEF and as there was statistically relevant benefit across all 3 domains, fundamentally this is important as it gives healthcare teams a treatment option for treating HFpEF and HFmrEF.</p> <p>Dapagliflozin, without question, overcomes and address the current treatment drought.</p>
<p>10. If there are disadvantages of dapagliflozin over current treatments on the NHS please describe these.</p>	<p>There are no current treatments on the NHS. Dapagliflozin is well tolerated with limited side-effects. I have no concerns about side effects as long as the patient is aware of them and they are dealt with by their healthcare team.</p>

<p>For example, are there any risks with dapagliflozin? If you are concerned about any potential side effects you have heard about, please describe them and explain why</p>	
<p>11. Are there any groups of patients who might benefit more from dapagliflozin or any who may benefit less? If so, please describe them and explain why</p> <p>Consider, for example, if patients also have other health conditions (for example difficulties with mobility, dexterity or cognitive impairments) that affect the suitability of different treatments</p>	<p>All patient with all heart failure types benefit. Those with heart failure who do not have Type II Diabetes and reduced Kidney Function must benefit. The tablet is easy to take and should not disrupt the patients' other medications. It is well tolerated.</p>
<p>12. Are there any potential equality issues that should be taken into account when considering chronic heart failure with preserved or mildly reduced ejection fraction and dapagliflozin? Please explain if you think any groups of people with this condition are particularly disadvantaged</p> <p>Equality legislation includes people of a particular age, disability, gender reassignment, marriage and civil partnership, pregnancy and maternity, race, religion or belief, sex, and sexual orientation or people with any other shared characteristics</p> <p>More information on how NICE deals with equalities issues can be found in the NICE equality scheme Find more general information about the Equality Act and equalities issues here.</p>	<p>The system and process for prescribing may disadvantage and call into question whether all patients would have equal access and equity of opportunity to be prescribed. GP's know SGLT2i's very well, they have been prescribed without specialist involvement in Type II Diabetes for many years. There should be no reason to refer for specialist reassessment or advice when prescribing SGLT2i's in Primary Care.</p> <p>Referring for specialist assessment and or initiation is just another burden to the NHS where –</p> <ul style="list-style-type: none"> Waiting times increase Specialist caseloads increase Patients suffer <p>Time is important when prescribing HF medications therefore delay is detrimental to an already under invested population.</p>
<p>13. Are there any other issues that you would like the committee to consider?</p>	<p>No</p>

Part 2: Key messages

In up to 5 sentences, please summarise the key messages of your statement:

- Click or tap here to enter text.
- Click or tap here to enter text.
- Click or tap here to enter text.
- Click or tap here to enter text.
- Click or tap here to enter text.

Thank you for your time.

Your privacy

The information that you provide on this form will be used to contact you about the topic above.

Please tick this box if you would like to receive information about other NICE topics.

For more information about how we process your personal data please see [NICE's privacy notice](#).

Single Technology Appraisal

Dapagliflozin for treating chronic heart failure with preserved or mildly reduced ejection fraction [ID1648]

Clinical expert statement

Thank you for agreeing to provide your views on this technology and its possible use in the NHS.

You can provide a unique perspective on the technology in the context of current clinical practice that is not typically available from the published literature. The external assessment report (EAR) and stakeholder responses are used by the committee to help it make decisions at the committee meeting. Usually, only unresolved or uncertain key issues will be discussed at the meeting.

Information on completing this form

In [part 1](#) we are asking for your views on this technology. The text boxes will expand as you type.

In [part 2](#) we are asking you to provide 5 summary sentences on the main points contained in this document.

Please do not embed documents (such as a PDF) in a submission because this may lead to the information being mislaid or make the submission unreadable. Please type information directly into the form.

Do not include medical information about yourself or another person that could identify you or the other person.

We are committed to meeting the requirements of copyright legislation. If you want to include **journal articles** in your submission you must have copyright clearance for these articles. We can accept journal articles in NICE Docs. For copyright reasons, we will have to return forms that have attachments without reading them. You can resubmit your form without attachments, but it must be sent by the deadline.

Combine all comments from your organisation (if applicable) into 1 response. We cannot accept more than 1 set of comments from each organisation.

Clinical expert statement

Dapagliflozin for treating chronic heart failure with preserved or mildly reduced ejection fraction [ID1648]

1 of 10

Please underline all confidential information, and separately highlight information that is submitted under 'commercial in confidence' in turquoise, all information submitted under 'academic in confidence' in yellow, and all information submitted under 'depersonalised data' in pink. If confidential information is submitted, please also send a second version of your comments with that information replaced with the following text: 'academic/commercial in confidence information removed'. See the NICE [health technology evaluation guidance development manual](#) (sections 5.4.1 to 5.4.10) for more information.

The deadline for your response is **5pm on Wednesday 16 November**. Please log in to your NICE Docs account to upload your completed form, as a Word document (not a PDF).

Thank you for your time.

We reserve the right to summarise and edit comments received during engagement, or not to publish them at all, if we consider the comments are too long, or publication would be unlawful or otherwise inappropriate.

Comments received during engagement are published in the interests of openness and transparency, and to promote understanding of how recommendations are developed. The comments are published as a record of the comments we received, and are not endorsed by NICE, its officers or advisory committees.

Part 1: Treating chronic heart failure with preserved or mildly reduced ejection fraction and current treatment options

Table 1 About you, aim of treatment, place and use of technology, sources of evidence and equality

1. Your name	Lisa Anderson
2. Name of organisation	St George's University Hospitals NHS Foundation Trust
3. Job title or position	Consultant Cardiologist and Heart Failure Lead
4. Are you (please tick all that apply)	<input checked="" type="checkbox"/> An employee or representative of a healthcare professional organisation that represents clinicians? Chair-Elect of the British Society for Heart Failure <input checked="" type="checkbox"/> A specialist in the treatment of people with chronic heart failure with preserved or mildly reduced ejection fraction? <input checked="" type="checkbox"/> A specialist in the clinical evidence base for chronic heart failure with preserved or mildly reduced ejection fraction or technology? <input type="checkbox"/> Other (please specify):
5. Do you wish to agree with your nominating organisation's submission? (We would encourage you to complete this form even if you agree with your nominating organisation's submission)	<input checked="" type="checkbox"/> Yes, I agree with it <input type="checkbox"/> No, I disagree with it <input type="checkbox"/> I agree with some of it, but disagree with some of it <input type="checkbox"/> Other (they did not submit one, I do not know if they submitted one etc.)
6. If you wrote the organisation submission and/or do not have anything to add, tick here. (If you tick this box, the rest of this form will be deleted after submission)	<input type="checkbox"/> Yes
7. Please disclose any past or current, direct or indirect links to, or funding from, the tobacco industry.	

<p>8. What is the main aim of treatment chronic heart failure with preserved or mildly reduced ejection fraction?</p> <p>(For example, to stop progression, to improve mobility, to cure the condition, or prevent progression or disability)</p>	<p>The main goals of heart failure treatment are to:</p> <ul style="list-style-type: none"> Improve quality of life for patients Prevent hospital admissions Reduce cardiovascular mortality
<p>9. What do you consider a clinically significant treatment response?</p> <p>(For example, a reduction in tumour size by x cm, or a reduction in disease activity by a certain amount)</p>	<p>A significant improvement in quality of life with a validated scoring tool.</p> <p>Significantly reduced hospital admissions.</p> <p>Significantly reduced cardiovascular mortality.</p>
<p>10. In your view, is there an unmet need for patients and healthcare professionals in chronic heart failure with preserved or mildly reduced ejection fraction?</p>	<p>Yes. Approximately half of patients with HF have a preserved or mildly reduced left ventricular ejection fraction (HFpEF/HFmrEF). There is a high symptom burden with frequent hospital admissions and increasing frailty as a result. Until now, clinical trials of new therapeutic approaches have been characterised by efficacy failure, and treatment options remain very limited.</p>
<p>11. How is chronic heart failure with preserved or mildly reduced ejection fraction currently treated in the NHS?</p> <ul style="list-style-type: none"> • Are any clinical guidelines used in the treatment of the condition, and if so, which? • Is the pathway of care well defined? Does it vary or are there differences of opinion between professionals across the NHS? (Please state if your experience is from outside England.) • What impact would the technology have on the current pathway of care? 	<p>HFmrEF (EF 41-49%) – No RCT has been performed exclusively in this subgroup. However, because</p> <ul style="list-style-type: none"> -EF in heart failure is a spectrum and -due to the large benefits seen in patients with more reduced EF, - and because many of the patients in this cohort are believed to be patients with recovering EF, <p>the European Society of Cardiology Guidelines (2021) has made 2b recommendations (these drugs may be considered) for ACE inhibitors/Angiotensin II receptor blockers/neprilysin inhibitors, beta-blockers and mineralocorticoid receptor antagonists for treatment in this subgroup.</p> <p>HFpEF (EF > 50%) – Treatment is focussed on diuretic therapy and managing comorbidities such as atrial fibrillation, diabetes, hypertension, kidney disease. Weight loss in obese patients and increasing exercise may improve symptoms and exercise capacity.</p>

<p>12. Will the technology be used (or is it already used) in the same way as current care in NHS clinical practice?</p> <ul style="list-style-type: none"> • How does healthcare resource use differ between the technology and current care? • In what clinical setting should the technology be used? (for example, primary or secondary care, specialist clinic) • What investment is needed to introduce the technology? (for example, for facilities, equipment, or training) 	<p>The healthcare resource use does not differ from current care. Following initiation, the vast majority of patients require only routine monitoring. A subgroup of more complex diabetic patients will require increased home blood glucose checks for 1 week after initiation and recheck HbA1C at 3 months.</p> <p>The technology will be used in all areas where patients are seen – specialist care, and primary and secondary care following recommendation from a HF specialist.</p> <p>This technology is already used in the management of HF patients with reduced ejection fraction and in type 2 diabetes and is also licensed for chronic kidney disease. Little investment, other than the writing of Local Guidelines for use, would be needed.</p>
<p>13. Do you expect the technology to provide clinically meaningful benefits compared with current care?</p> <ul style="list-style-type: none"> • Do you expect the technology to increase length of life more than current care? • Do you expect the technology to increase health-related quality of life more than current care? 	<p>Yes, I expect the technology to provide clinically meaningful benefits compared with current care.</p> <p>Although a trend toward reduced cardiovascular mortality is seen, most of the effect on the primary end point was seen in reduced HF admissions.</p> <p>A highly significant improvement in the KCCQ QOL score was seen so I expect the technology to increase health related quality of life more than current care.</p>
<p>14. Are there any groups of people for whom the technology would be more or less effective (or appropriate) than the general population?</p>	<p>No. Subgroup analysis did not reveal heterogeneity in effectiveness.</p>
<p>15. Will the technology be easier or more difficult to use for patients or healthcare professionals than</p>	<p>Heart failure admissions increased by 33% in the 5 years pre-pandemic with the largest increases in HFpEF admissions and HF is the commonest cause for hospital admission in those >65years. NHS Hospitals are at capacity and a</p>

<p>current care? Are there any practical implications for its use? (For example, any concomitant treatments needed, additional clinical requirements, factors affecting patient acceptability or ease of use or additional tests or monitoring needed)</p>	<p>treatment that has a positive impact on HF admissions will help HF patients, overstretched HF clinical teams as well as the wider health system.</p>
<p>16. Will any rules (informal or formal) be used to start or stop treatment with the technology? Do these include any additional testing?</p>	<p>No additional testing is required before starting treatment and the treatment will be ongoing indefinitely once initiated.</p>
<p>17. Do you consider that the use of the technology will result in any substantial health-related benefits that are unlikely to be included in the quality-adjusted life year (QALY) calculation?</p> <ul style="list-style-type: none"> Do the instruments that measure quality of life fully capture all the benefits of the technology or have some been missed? For example, the treatment regimen may be more easily administered (such as an oral tablet or home treatment) than current standard of care 	<p>Reduced hospital admissions will greatly impact quality of life for both patients and families.</p>
<p>18. Do you consider the technology to be innovative in its potential to make a significant and substantial impact on health-related benefits and how might it improve the way that current need is met?</p> <ul style="list-style-type: none"> Is the technology a 'step-change' in the management of the condition? Does the use of the technology address any particular unmet need of the patient population? 	<p>Yes. Until now all no evidence-based therapy has been available for HFpEF/HFmrEF patients. The therapy addresses the major unmet needs of reducing hospital admissions and improving quality of life.</p>
<p>19. How do any side effects or adverse effects of the technology affect the management of the condition and the patient's quality of life?</p>	<p>Serious adverse events were reported in 1361 patients (43.5%) in the dapagliflozin group and in 1423 patients (45.5%) in the placebo group. Adverse events that led to discontinuation of dapagliflozin or placebo were reported in</p>

	182 patients (5.8%) in the dapagliflozin group and in 181 patients (5.8%) in the placebo group. Patients are warned about the potential increase in genitourinary fungal infections and the need for sick day rules to reduce the risk of diabetic ketoacidosis.
<p>20. Do the clinical trials on the technology reflect current UK clinical practice?</p> <ul style="list-style-type: none"> • If not, how could the results be extrapolated to the UK setting? • What, in your view, are the most important outcomes, and were they measured in the trials? • If surrogate outcome measures were used, do they adequately predict long-term clinical outcomes? • Are there any adverse effects that were not apparent in clinical trials but have come to light subsequently? 	<p>Yes.</p> <p>The most important outcomes were measured in the trial (QOL, HF hospitalisations and CV death).</p> <p>I am not aware of adverse events not apparent in the clinical trials that have come to light subsequently.</p>
<p>21. Are you aware of any relevant evidence that might not be found by a systematic review of the trial evidence?</p>	No
<p>22. How do data on real-world experience compare with the trial data?</p>	Since the publication of the data, it is likely that this medication has already been initiated for many admitted HFpEF patients. Many of these patients already meet other indications for SGLT2- (type 2 diabetes or CKD with proteinuria). The medication is well tolerated – in particular, given the frail, comorbid population, there is minimal effect on blood pressure or worsening of renal function
<p>23. NICE considers whether there are any equalities issues at each stage of an evaluation. Are there any potential equality issues that should be taken into account when considering this condition and this treatment? Please explain if you think any groups of people with this condition are particularly disadvantaged.</p>	No.

Equality legislation includes people of a particular age, disability, gender reassignment, marriage and civil partnership, pregnancy and maternity, race, religion or belief, sex, and sexual orientation or people with any other shared characteristics.

Please state if you think this evaluation could

- exclude any people for which this treatment is or will be licensed but who are protected by the equality legislation
- lead to recommendations that have a different impact on people protected by the equality legislation than on the wider population
- lead to recommendations that have an adverse impact on disabled people.

Please consider whether these issues are different from issues with current care and why.

More information on how NICE deals with equalities issues can be found in the [NICE equality scheme](#).

[Find more general information about the Equality Act and equalities issues here.](#)

Part 2: Key messages

In up to 5 sentences, please summarise the key messages of your statement:

At present, the disease trajectory and quality of life for patients with HFpEF and HFmrEF is poor.

There are currently no pharmacological treatment options shown to reduce hospital admission or improve quality of life for these patients

This technology will make a real and meaningful difference to NHS care for patients with HFmrEF and HFpEF

In the UK there are around 100,000 HF admissions annually, with a long length of stay (10 days mean), so a technology with an impact on reduced admissions will have wider benefits for an NHS system currently running at capacity.

Prevalence of HFmrEF and HFpEF is increasing in the UK, and these subgroups represent a large and growing proportion of heart failure admissions to hospital.

Thank you for your time.

Your privacy

The information that you provide on this form will be used to contact you about the topic above.

Please tick this box if you would like to receive information about other NICE topics.

Clinical expert statement

Dapagliflozin for treating chronic heart failure with preserved or mildly reduced ejection fraction [ID1648]

For more information about how we process your personal data please see our [privacy notice](#).

Single Technology Appraisal

Dapagliflozin for treating chronic heart failure with preserved or mildly reduced ejection fraction [ID1648]

Clinical expert statement

Thank you for agreeing to provide your views on this technology and its possible use in the NHS.

You can provide a unique perspective on the technology in the context of current clinical practice that is not typically available from the published literature. The external assessment report (EAR) and stakeholder responses are used by the committee to help it make decisions at the committee meeting. Usually, only unresolved or uncertain key issues will be discussed at the meeting.

Information on completing this form

In [part 1](#) we are asking for your views on this technology. The text boxes will expand as you type.

In [part 2](#) we are asking you to provide 5 summary sentences on the main points contained in this document.

Please do not embed documents (such as a PDF) in a submission because this may lead to the information being mislaid or make the submission unreadable. Please type information directly into the form.

Do not include medical information about yourself or another person that could identify you or the other person.

We are committed to meeting the requirements of copyright legislation. If you want to include **journal articles** in your submission you must have copyright clearance for these articles. We can accept journal articles in NICE Docs. For copyright reasons, we will have to return forms that have attachments without reading them. You can resubmit your form without attachments, but it must be sent by the deadline.

Combine all comments from your organisation (if applicable) into 1 response. We cannot accept more than 1 set of comments from each organisation.

Clinical expert statement

Dapagliflozin for treating chronic heart failure with preserved or mildly reduced ejection fraction [ID1648]

1 of 10

Please underline all confidential information, and separately highlight information that is submitted under 'commercial in confidence' in turquoise, all information submitted under 'academic in confidence' in yellow, and all information submitted under 'depersonalised data' in pink. If confidential information is submitted, please also send a second version of your comments with that information replaced with the following text: 'academic/commercial in confidence information removed'. See the NICE [health technology evaluation guidance development manual](#) (sections 5.4.1 to 5.4.10) for more information.

The deadline for your response is **5pm on Friday 28 October**. Please log in to your NICE Docs account to upload your completed form, as a Word document (not a PDF).

Thank you for your time.

We reserve the right to summarise and edit comments received during engagement, or not to publish them at all, if we consider the comments are too long, or publication would be unlawful or otherwise inappropriate.

Comments received during engagement are published in the interests of openness and transparency, and to promote understanding of how recommendations are developed. The comments are published as a record of the comments we received, and are not endorsed by NICE, its officers or advisory committees.

Part 1: Treating chronic heart failure with preserved or mildly reduced ejection fraction and current treatment options

Table 1 About you, aim of treatment, place and use of technology, sources of evidence and equality

1. Your name	Andrew Ludman
2. Name of organisation	British Cardiovascular Society
3. Job title or position	Consultant Cardiologist
4. Are you (please tick all that apply)	<input type="checkbox"/> An employee or representative of a healthcare professional organisation that represents clinicians? <input checked="" type="checkbox"/> A specialist in the treatment of people with chronic heart failure with preserved or mildly reduced ejection fraction? <input type="checkbox"/> A specialist in the clinical evidence base for chronic heart failure with preserved or mildly reduced ejection fraction or technology? <input type="checkbox"/> Other (please specify):
5. Do you wish to agree with your nominating organisation's submission? (We would encourage you to complete this form even if you agree with your nominating organisation's submission)	<input checked="" type="checkbox"/> Yes, I agree with it <input type="checkbox"/> No, I disagree with it <input type="checkbox"/> I agree with some of it, but disagree with some of it <input type="checkbox"/> Other (they did not submit one, I do not know if they submitted one etc.)
6. If you wrote the organisation submission and/or do not have anything to add, tick here. (If you tick this box, the rest of this form will be deleted after submission)	<input type="checkbox"/> Yes
7. Please disclose any past or current, direct or indirect links to, or funding from, the tobacco industry.	None

<p>8. What is the main aim of treatment chronic heart failure with preserved or mildly reduced ejection fraction?</p> <p>(For example, to stop progression, to improve mobility, to cure the condition, or prevent progression or disability)</p>	<p>Main aim depends on view point. Key aims from a healthcare provider perspective are to reduce hospital admission and cardiovascular mortality. From a patient perspective reduction in symptoms of breathlessness is very important.</p>
<p>9. What do you consider a clinically significant treatment response?</p> <p>(For example, a reduction in tumour size by x cm, or a reduction in disease activity by a certain amount)</p>	<p>Any reduction in hospital admission or mortality is welcome and is significant for that patient.</p>
<p>10. In your view, is there an unmet need for patients and healthcare professionals in chronic heart failure with preserved or mildly reduced ejection fraction?</p>	<p>Yes. There are few (if any) evidence based treatments in this condition.</p>
<p>11. How is chronic heart failure with preserved or mildly reduced ejection fraction currently treated in the NHS?</p> <ul style="list-style-type: none"> • Are any clinical guidelines used in the treatment of the condition, and if so, which? • Is the pathway of care well defined? Does it vary or are there differences of opinion between professionals across the NHS? (Please state if your experience is from outside England.) • What impact would the technology have on the current pathway of care? 	<p>Treatment guidelines are written by the European Society of Cardiology as part of the overall heart failure guideline.</p> <p>The mainstay of treatment for HFpEF has been treatment of the contributing co-morbidities (e.g. hypertension, rate control of atrial fibrillation etc) as well as fluid balance management with diuretics. There is some evidence for spironolactone.</p> <p>The diagnostic pathway is defined via the investigation of heart failure NICE guideline in the UK. However the diagnosis is not always easy.</p> <p>The SGLT2i are really the first medication in this condition to demonstrate a significant benefit. Therefore this group of medications is likely to be adopted widely, with hopefully the same real-life benefit.</p>
<p>12. Will the technology be used (or is it already used) in the same way as current care in NHS clinical practice?</p>	<p>The SGLT2i medications are already used for a number of indications within the NHS and so their use could be adapted safely and rapidly if approved.</p>

<ul style="list-style-type: none"> • How does healthcare resource use differ between the technology and current care? • In what clinical setting should the technology be used? (for example, primary or secondary care, specialist clinic) • What investment is needed to introduce the technology? (for example, for facilities, equipment, or training) 	<p>There is likely to be a resource implication in terms of higher medication cost, albeit somewhat balanced by a reduction in hospital admission and the quality of life benefit around symptoms.</p> <p>I would suggest that empagliflozin could be used in line with SGLT2i for HFrEF which is prescribed in primary care following advice of a specialist heart failure team member.</p> <p>Alerting healthcare professionals to the new guidance and providing some education may be required.</p>
<p>13. Do you expect the technology to provide clinically meaningful benefits compared with current care?</p> <ul style="list-style-type: none"> • Do you expect the technology to increase length of life more than current care? • Do you expect the technology to increase health-related quality of life more than current care? 	<p>There is no conclusive evidence of a decrease in overall mortality in the main current study of dapagliflozin in HFpEF, although there was a numerical reduction in cardiovascular death.</p> <p>Health related QoL is likely to be increased in comparison to current care with a reduction in the risk of heart failure worsening or hospitalisation and a decrease in symptoms (as measured by KCCQ score).</p>
<p>14. Are there any groups of people for whom the technology would be more or less effective (or appropriate) than the general population?</p>	<p>The majority of trial participants have a white ethnicity with smaller numbers of other ethnic groups. No clinical difference in response between groups has been detected. Further evaluation may allow confirmation of equal clinical effect in all.</p>
<p>15. Will the technology be easier or more difficult to use for patients or healthcare professionals than current care? Are there any practical implications for its use?</p> <p>(For example, any concomitant treatments needed, additional clinical requirements, factors affecting patient</p>	<p>Straightforward usage for primary and secondary care professionals.</p>

acceptability or ease of use or additional tests or monitoring needed)	
16. Will any rules (informal or formal) be used to start or stop treatment with the technology? Do these include any additional testing?	A diagnosis of heart failure with preserved or mildly reduced ejection fraction should be made. Symptomatic (NYHA II or greater).
17. Do you consider that the use of the technology will result in any substantial health-related benefits that are unlikely to be included in the quality-adjusted life year (QALY) calculation? <ul style="list-style-type: none"> Do the instruments that measure quality of life fully capture all the benefits of the technology or have some been missed? For example, the treatment regimen may be more easily administered (such as an oral tablet or home treatment) than current standard of care 	No
18. Do you consider the technology to be innovative in its potential to make a significant and substantial impact on health-related benefits and how might it improve the way that current need is met? <ul style="list-style-type: none"> Is the technology a 'step-change' in the management of the condition? Does the use of the technology address any particular unmet need of the patient population? 	Yes this a step change in management. The first medication to show a meaningful difference in clinical outcomes for HFpEF. Patients with HFpEF have a significant unmet need in terms of treatments to improve symptoms, quality of life and reduce deterioration. The SGLT2i go someway towards this.
19. How do any side effects or adverse effects of the technology affect the management of the condition and the patient's quality of life?	The incidence of adverse effects is similar to placebo. For empagliflozin a small increase in uncomplicated urinary infections was reported in the main study in this group of patients.
20. Do the clinical trials on the technology reflect current UK clinical practice? <ul style="list-style-type: none"> If not, how could the results be extrapolated to the UK setting? 	Yes, the clinical trials reflect UK practice. The most important outcomes were assessed in the clinical trial.

<ul style="list-style-type: none"> • What, in your view, are the most important outcomes, and were they measured in the trials? • If surrogate outcome measures were used, do they adequately predict long-term clinical outcomes? • Are there any adverse effects that were not apparent in clinical trials but have come to light subsequently? 	<p>No additional adverse events have come to light.</p>
<p>21. Are you aware of any relevant evidence that might not be found by a systematic review of the trial evidence?</p>	<p>No</p>
<p>22. How do data on real-world experience compare with the trial data?</p>	<p>SGLT2i are used for a number of indications already and real world experience is similar to that presented in the trials.</p> <p>Patients and professionals are concerned about the risk of urinary infection and it is difficult to balance the relative risks/benefits around this.</p>
<p>23. NICE considers whether there are any equality issues at each stage of an evaluation. Are there any potential equality issues that should be taken into account when considering this condition and this treatment? Please explain if you think any groups of people with this condition are particularly disadvantaged.</p> <p>Equality legislation includes people of a particular age, disability, gender reassignment, marriage and civil partnership, pregnancy and maternity, race, religion or belief, sex, and sexual orientation or people with any other shared characteristics.</p> <p>Please state if you think this evaluation could</p>	<p>Patients with HFpEF are often older, may have multiple medical problems and a higher degree of frailty and as such are often harder to reach with new medical innovations. Where possible specific evidence based recommendations for this group would be useful.</p>

- exclude any people for which this treatment is or will be licensed but who are protected by the equality legislation
- lead to recommendations that have a different impact on people protected by the equality legislation than on the wider population
- lead to recommendations that have an adverse impact on disabled people.

Please consider whether these issues are different from issues with current care and why.

More information on how NICE deals with equalities issues can be found in the [NICE equality scheme](#).

[Find more general information about the Equality Act and equalities issues here.](#)

Part 2: Key messages

In up to 5 sentences, please summarise the key messages of your statement:

SGLT2i (specifically empagliflozin and dapagliflozin) are already approved for treatment of heart failure with reduced ejection fraction.

There is robust clinical trial evidence of benefit for empagliflozin and dapagliflozin in the treatment of heart failure with preserved ejection fraction.

There are few if any other specific treatments for heart failure and preserved ejection fraction.

Click or tap here to enter text.

Click or tap here to enter text.

Click or tap here to enter text.

Click or tap here to enter text.

Thank you for your time.

Your privacy

The information that you provide on this form will be used to contact you about the topic above.

Please tick this box if you would like to receive information about other NICE topics.

For more information about how we process your personal data please see our [privacy notice](#).



Dapagliflozin for treating chronic heart failure with preserved or mildly reduced ejection fraction (ID1648)

STA Report

Source of funding

This report was commissioned by the NIHR Evidence Synthesis Programme as project number 135673.

Title: Dapagliflozin for treating chronic heart failure with preserved or mildly reduced ejection fraction (ID1648)

Produced by: BMJ Technology Assessment Group (BMJ-TAG)

Authors: Steve Edwards, Director of Health Technology Assessment, BMJ-TAG, London
Nicole Downes, Senior Clinical Evidence Analyst, BMJ-TAG, London
Archie Walters, Health Economist, BMJ-TAG, London
Gemma Marceniuk, Senior Health Economist, BMJ-TAG, London

Correspondence to: Steve Edwards, BMJ-TAG, BMJ, BMA House, Tavistock Square, London, WC1H 9JR.

Date completed: 24/11/2022

Source of funding: This report was commissioned by the NIHR Evidence Synthesis Programme as project number 135673.

Declared competing interests of the authors: No competing interests were declared which affect the impartiality of this report. BMJ Technology Assessment Group (BMJ-TAG) and the editorial team of The BMJ work independently to one another. The views and opinions expressed in this report are those of the BMJ-TAG.

Acknowledgments: The EAG would like to thank Dr Will Nicolson, Consultant Cardiologist at Glenfield Hospital, University Hospitals of Leicester NHS Trust, and Dr Rosita Zakeri, Honorary Consultant Cardiologist at King's College Hospital and Guys & St Thomas' NHS Trust, for providing clinical advice throughout the project, and for providing feedback on the clinical sections of the report.

Rider on responsibility for report: The views expressed in this report are those of the authors and not necessarily those of the NIHR Evidence Synthesis Programme. Any errors are the responsibility of the authors.

Report reference: Edwards SJ, Downes N, Walters A, Marceniuk G. Dapagliflozin for treating chronic heart failure with preserved or mildly reduced ejection fraction: A Single Technology Appraisal. BMJ Technology Assessment Group, 2022.

Copyright is retained by AstraZeneca for Figures 1-6 and Tables 20-22, 24, 28-34 and 36.

Contribution of authors:

Steve Edwards	Critical appraisal of the company's submission; validated the statistical analyses; provided feedback on all versions of the report. Guarantor of the report
Nicole Downes	Critical appraisal of the company's submission and the clinical evidence; drafted and reviewed the clinical sections of the report
Archie Walters	Critical appraisal of the company's submission; critical appraisal of the economic model; cross checking of company's search strategies; critical appraisal of the economic evidence; carried out the economic analyses; and drafted the economic sections
Gemma Marceniuk	Critical appraisal of the company's submission; critical appraisal of the economic model; cross checking of company's search strategies; critical appraisal of the economic evidence; carried out the economic analyses; and drafted the economic sections

All authors read and commented on draft versions of the EAG report.

Table of Contents

Table of Contents.....	4
List of Tables	7
List of Figures	10
List of Abbreviations	11
1 Executive summary	14
1.1 Overview of the EAG’s key issues	14
1.2 Overview of key model outcomes	14
1.3 Summary of the EAG’s key issues	15
1.4 Summary of EAG’s preferred assumptions and resulting ICER.....	18
2 Introduction and background	19
2.1 Introduction	19
2.2 Background	19
2.2.1 Positioning of dapagliflozin in the UK treatment pathway.....	21
2.3 Critique of the company’s definition of the decision problem.....	22
2.3.1 Population	28
2.3.2 Intervention and comparator	30
2.3.3 Outcomes.....	31
2.3.4 Subgroups	32
3 Clinical effectiveness.....	33
3.1 Critique of the methods review	33
3.2 Critique of trials of the technology of interest	35

3.3	Critique of the clinical effectiveness analysis	41
3.3.1	Heart failure events, mortality and hospitalisation	41
3.3.2	Quality of life.....	43
3.3.3	Treatment discontinuation	44
3.3.4	Adverse events.....	45
3.3.5	Subgroups	48
3.4	Conclusions of the clinical effectiveness section	55
4	Cost effectiveness	57
4.1	EAG comment on the company’s review of cost effectiveness evidence	57
4.2	Summary and critique of company’s submitted economic evaluation by the EAG	60
4.2.1	NICE reference case checklist	60
4.2.2	Population.....	61
4.2.3	Interventions and comparators	62
4.2.4	Modelling approach and model structure	63
4.2.5	Perspective, time horizon and discounting.....	64
4.2.6	Treatment effectiveness	64
4.2.7	Health-related quality of life.....	76
4.2.8	Resource use and cost	80
5	Cost effectiveness results	86
5.1.1	Company’s cost effectiveness results	86
5.1.2	Company’s sensitivity analyses.....	88
5.1.3	Model validation and face validity check.....	93

6	Additional economic analysis undertaken by the EAG	94
6.1	Model corrections	94
6.2	Exploratory and sensitivity analyses undertaken by the EAG.....	94
6.3	EAG scenario analysis.....	94
6.4	EAG preferred assumptions	95
6.5	Conclusions of the cost effectiveness sections.....	98
7	References	100
8	Appendices.....	106
8.1	Additional subgroup strategies.....	106
8.1.1	SBP \leq 128 mmHg vs >128 mmHg	106
8.1.2	BMI \geq 30 kg/m ² vs <30 kg/m ²	107

List of Tables

Table 1. Summary of key issues	14
Table 2. Issue 1. Inclusion of amputation as an AE in the economic model.....	15
Table 3. Issue 2. Estimation of AE transition probabilities in the economic model	16
Table 4. Issue 3. Underestimation of CV mortality in the economic model	16
Table 5. Issue 4. The impact of dapagliflozin on patients' survival.....	17
Table 6. Issue 5. Using appropriate NHS reference costs in the economic model	17
Table 7. Issue 6. Overestimation of HHF costs in the economic model	18
Table 8. EAG's preferred model assumptions.....	18
Table 9. Summary of decision problem	23
Table 10. Summary of the EAG's critique of the methods implemented by the company to identify evidence relevant to dapagliflozin use in HF with LVEF >40%.....	34
Table 11. A summary of the EAG's critique of the design, conduct and analysis of the DELIVER trial.	37
Table 12. Proportion with events in each arm and HRs for dapagliflozin + SoC vs. SoC in the overall FAS population of the DELIVER trial (adapted from Table 11 of the CS)	42
Table 13. Summary of adverse events in the safety population – DELIVER trial (adapted from Tables 22 and 23 of the CS), on-treatment events	46
Table 14. Outcomes of interest for prior LVEF ≤40% vs consistent LVEF >40% subgroups.....	49
Table 15. Outcomes of interest for T2DM vs no T2DM subgroups – dichotomous outcomes	52
Table 16. Outcomes of interest for T2DM vs no T2DM subgroups – KCCQ-TSS change from baseline scores	53
Table 17. Company's base case results (adapted from Table 59 of the CS)	57
Table 18. Critique of the methods implemented by the company to identify relevant health economic evidence	58

Table 19. NICE reference case checklist.....	60
Table 20: Adjusted GEEs predicting UHFV events (reproduced from Table 41 in the CS).....	66
Table 21. Unadjusted GEE coefficients derived from the DELIVER trial (reproduced from Table 42 in the CS).....	67
Table 22. Stratification of DELIVER amputation events by T2DM status (reproduced from Table 13 in the company’s response to clarification question B2)	68
Table 23. Adverse event probabilities of dapagliflozin trials in HF populations (adapted from table 44 of the CS).....	70
Table 24. Summary of treatment effect for dapagliflozin versus SoC based on prior LVEF status (reproduced from Table 7 of the company’s response to clarification question A7).....	75
Table 25. HSUVs used in the economic model (adapted from Tables 45 and 62 of the CS)	77
Table 26. Mean HSUVs across the dapagliflozin trials (adapted from Table 45 in the CS).....	77
Table 27. Alternative HSUVs when Q4 is set equal to the general population utility (adapted from Table 62 in the CS)	78
Table 28. Utility decrements used for HF events (reproduced from Table 46 of the CS).....	79
Table 29. Utility decrements used for AEs (reproduced from Table 47 of the CS).....	80
Table 30. Treatment acquisition costs included in the model (reproduced from Table 49 of the CS).	81
Table 31. Health state costs included in the model (reproduced from Tables 51 and 52 of the CS) ...	82
Table 32. Unit costs for HF events (reproduced from Table 50 of the CS)	83
Table 33. Unit costs for mortality events (adapted from Table 50 of the CS)	84
Table 34. Unit costs for AEs (adapted from Table 53 of the CS).....	85
Table 35. Company’s base case results, post clarification.....	86
Table 36. Company scenario analysis results (reproduced from Figure 31 in the CQ responses)	89

Table 37. Results of the EAG’s scenario analyses	94
Table 38. EAG’s preferred model assumptions.....	95
Table 39. EAG’s base case	96
Table 40. Deterministic scenarios around the EAG base case.....	96
Table 41. Outcomes of interest for SBP \leq 128 mmHg vs $>$ 128 mmHg subgroups.....	107

List of Figures

Figure 1. Schematic of Markov state-transition model structure, health states, and possible transitions (reproduced form Figure 18 of the CS).....	63
Figure 2. Adjusted survival model extrapolations for CV mortality (reproduced from Figure 21 of the CS)	72
Figure 3. Adjusted survival model extrapolations for all-cause mortality (reproduced from Figure 22 of the CS).....	72
Figure 4. Cost-effectiveness scatter plot from PSA (reproduced from Figure 13 of the company’s clarification response appendix).....	87
Figure 5. Cost effectiveness acceptability curve from PSA (reproduced from Figure 14 of the company’s clarification response appendix)	87
Figure 6. Tornado plot of OWSA results (reproduced from Figure 28 in the CS)	88
Figure 7. Cost-effectiveness scatter plot from PSA with the EAGs preferred assumptions	97
Figure 8. CEAC from PSA with the EAGs preferred assumptions.....	97
Figure 9. Tornado plot of OWSA results with the EAGs preferred assumptions	98

List of Abbreviations

A&E	Accident and emergency
ACC	American College of Cardiology
ACEi	Angiotensin converting enzyme inhibitor
AE	Adverse event
AFF	Atrial fibrillation/flutter
AHA	American Heart Association
AIC	Akaike information criteria
AKI	Acute kidney injury
ARB	Angiotensin receptor blocker
ARNI	Angiotensin receptor neprilysin inhibitor
BCS	British Cardiovascular Society
BIC	Bayesian information criterion
BMI	Body mass index
BNF	British National Formulary
CEA	Clinical Events Adjudication
CEAC	Cost-effectiveness acceptability curve
CI	Confidence interval
CII	Cost inflation index
CKD	Chronic kidney disease
CPRD	Clinical Practice Research Datalink
CRD	Centre for Reviews and Dissemination
CRF	Case report form
CS	Company submission
CSR	Clinical study report
CV	Cardiovascular
DAE	Adverse event leading to treatment discontinuation
DSU	Decision Support Unit
EAG	External Assessment Group
EEPRU	Economic Methods of Evaluation in Health and Social Care Policy Research Unit
EMC	Electronic medicines compendium
eMIT	electronic marketing tool
EQ-5D-3L	EuroQol-5 Dimensions-3 Levels
EQ-5D-5L	EuroQol-5 Dimensions-5 Levels
ESC	European Society of Cardiology
EU	Europe
FAC	Factual accuracy check
FAS	Full analysis set
GEE	Generalising estimating equation
GP	General practitioner

HbA1c	Haemoglobin A1c
HF	Heart failure
HFA	Health Failure Association
HFimpEF	Heart failure with an improved ejection fraction
HFmrEF	Heart failure with a mildly reduced ejection fraction
HFpEF	Heart failure with a preserved ejection fraction
HFrEF	Heart failure with a reduced ejection fraction
HHF	Hospitalisation for heart failure
HR	Hazard ratio
HRQoL	Health-related quality of life
HSUV	Health-state utility value
HTA	Health technology appraisal
ICER	Incremental cost-effectiveness ratio
IHD	Ischaemic heart disease
INAHTA	International Network of Agencies for Health Technology Assessment
IP	Investigational product
ITT	Intention-to-treat
IWRS	interactive web-response system
KCCQ	Kansas City Cardiomyopathy Questionnaire
KCCQ-CSS	Kansas City Cardiomyopathy Questionnaire Clinical Summary Score
KCCQ-TSS	Kansas City Cardiomyopathy Questionnaire Total Symptom Score
KM	Kaplan-Meier
LOCF	Last observation carried forward
LoS	Length of stay
LVEF	Left ventricular ejection fraction
LYG	Life years gained
MHRA	Medicines and Healthcare Products Regulatory Agency
MI	Myocardial infarction
MRA	Mineralocorticoid-receptor antagonist
N/A	Not applicable
NHB	Net health benefit
NHS	National Health Service
NHSCII	National Health Service Cost Inflation Index
NICE	National Institute for Health and Care Excellence
NMA	Network meta-analysis
NMB	Net monetary benefit
NR	Not reported
NT-proBNP	N-terminal pro B-type natriuretic peptide
NYHA	New York Heart Association
OR	Odds ratio

OWSA	One-way sensitivity analysis
PACD	Primary analysis censoring date
PRISMA	Preferred Reporting Items for Systematic Reviews and Meta-Analyses
PSA	Probabilistic sensitivity analysis
PSS	Personal Social Services
PSSRU	Personal Social Services Research Unit
QALY	Quality-adjusted life year
QIC	Quasi-information criterion
RCT	Randomised controlled trial
SAE	Serious adverse event
SAS	Safety analysis set
SBP	Systolic blood pressure
SD	Standard deviation
SE	Standard error
SGLT2	Sodium-glucose-co-transporter-2
SIGN	Scottish Intercollegiate Guidelines Network
SLR	Systematic literature review
SmPC	Summary of Product Characteristics
SoC	Standard of care
STA	Single Technology Appraisal
T2DM	Type 2 diabetes mellitus
TA	Technology Appraisal
TSD	Technical support document
TSS	Total Symptom Score
UHFV	Urgent heart failure visit
UKPDS	United Kingdom Prospective Diabetes Study
UTI	Urinary tract infection
WTP	Willingness-to-pay threshold

1 Executive summary

This summary provides a brief overview of the key issues identified by the External Assessment Group (EAG) as being potentially important for decision making. It also includes the EAG's preferred assumptions and the resulting incremental cost-effectiveness ratios (ICERs).

Section 1.1 provides an overview of the key issues. Section 1.2 provides an overview of key model outcomes and the modelling assumptions that have the greatest effect on the ICER. Section 1.3 explains the key issues in more detail. Background information on the condition, technology and evidence and information on non-key issues are in the main EAG report.

All issues identified represent the EAG's view, not the opinion of the National Institute for Health and Care Excellence (NICE).

1.1 Overview of the EAG's key issues

Table 1. Summary of key issues

Issue	Summary of issue	Report sections
1	Inclusion of amputation as an AE in the economic model	1.3, 4.2.6.3
2	Estimation of AE transition probabilities in the economic model	1.3, 4.2.6.3
3	Underestimation of CV mortality in the economic model	1.3, 4.2.6.4
4	The impact of dapagliflozin on patient's survival	1.3, 4.2.6.4
5	Using appropriate NHS reference costs in the economic model	1.3, 4.2.8.3, 4.2.8.5
6	Overestimation of HHF costs in the economic model	1.3, 4.2.8.3

Abbreviations: AE, adverse event; CV, cardiovascular; HHF, hospitalisation for heart failure; NHS, National Health Service.

1.2 Overview of key model outcomes

NICE technology appraisals compare how much a new technology improves length (overall survival) and quality of life in a quality-adjusted life year (QALY). An ICER is the ratio of the extra cost for every QALY gained.

Overall, the technology is modelled to affect QALYs by:

- adverse events;
- heart failure (HF) events (hospitalisation for heart failure [HHF] and urgent heart failure visits [UHFV]);

- Kansas City Cardiomyopathy Questionnaire Total Symptom Score (KCCQ-TSS) quartile health state transitions;
- cardiovascular (CV) and non-CV mortality.

Overall, the technology is modelled to affect costs by:

- adverse events;
- HF events (HHF and UHFV);
- CV and non-CV mortality.

The modelling assumptions that have the greatest effect on the ICER are:

- dapagliflozin mortality treatment effects;
- dapagliflozin HF event (HHF and UHFV) treatment effects.

1.3 Summary of the EAG’s key issues

Table 2. Issue 1. Inclusion of amputation as an AE in the economic model

Report section	4.2.6.3
Description of issue and why the EAG has identified it as important	Amputation AEs are a key driver of the economic model. The EAG does not consider amputation to be a typical AE associated with HF and, on stratifying the data, [REDACTED] amputations occurred in those with T2DM and a [REDACTED] in the group without T2DM. The company’s concern about a link between SGLT2 inhibitors and amputation events was also not shared by the EAG’s clinical experts.
What alternative approach has the EAG suggested?	Given that dapagliflozin is already an approved treatment for T2DM (TA288, TA390 and TA418), and that amputations are not thought to be a typical AE associated with HF, to avoid confounding the EAG considers it inappropriate to include these in the economic model. The company provided a scenario with amputations removed from the economic model at clarification and the EAG prefers this assumption in its base case.
What is the expected effect on the cost-effectiveness estimates?	When amputation as an AE is removed from the economic model the ICER increases from £7,519 to £8,538; an increase of £1,019.
What additional evidence or analyses might help to resolve this key issue?	N/A

Abbreviations: AE, adverse event; EAG, External Assessment Group; HF, heart failure; ICER, incremental cost-effectiveness ratios; N/A, not applicable; SGLT2, sodium-glucose-co-transporter-2; T2DM, type 2 diabetes mellitus; TA, technology appraisal.

Table 3. Issue 2. Estimation of AE transition probabilities in the economic model

Report section	4.2.6.3
Description of issue and why the EAG has identified it as important	AE probabilities appear to lack external validity in that the probabilities of AEs appear markedly reduced when compared to the previous dapagliflozin (TA679) and empagliflozin (TA773) appraisals even though the HFpEF population is generally older with more managed comorbidities compared to HFrEF patients. The difference in probabilities is much as ■ in some cases.
What alternative approach has the EAG suggested?	At clarification, the company explored the impact of using different probabilities sourced from TA679 as requested by the EAG. This was also explored as a scenario by the EAG rather than in the EAG's base case.
What is the expected effect on the cost-effectiveness estimates?	The use of probabilities of AEs from TA679 led to an increase in the ICER of £916, from £7,519 to £8,435.
What additional evidence or analyses might help to resolve this key issue?	N/A
Abbreviations: AE, adverse event; EAG, External Assessment Group; ICER, incremental cost-effectiveness ratios; N/A, not applicable; TA, technology appraisal.	

Table 4. Issue 3. Underestimation of CV mortality in the economic model

Report section	4.2.6.4
Description of issue and why the EAG has identified it as important	The company's base case Weibull extrapolations are likely to be greatly underestimating CV mortality (~■% of patients had not died due to CV mortality at 92 years old) and mildly underestimating all-cause mortality (■% survival at 92 years old). However, there is only one other extrapolation which has a higher rate of CV and all-cause mortality compared to the Weibull, the Gompertz, which appears too pessimistic (■% survival at 88 and 83 years for CV and all-cause mortality, respectively).
What alternative approach has the EAG suggested?	The EAG has suggested using a single parametric model to extrapolate the data in comparison to the piece wise approach taken by the company. By extrapolating using the complete trial data and not just data post the point of inflection the EAG expects this may provide a more generalisable predictor of mortality.
What is the expected effect on the cost-effectiveness estimates?	As seen in the company's scenario, the use of an extrapolation with a more pessimistic CV and all-cause mortality extrapolation compared to the company's base case leads to an increase in the ICER to £9,590.
What additional evidence or analyses might help to resolve this key issue?	A clinical rationale to explain why an inflection point between the trial arms would be expected would be useful to support not using a single parametric model. If this inflection point was biologically plausible then the EAG would be less concerned about the use of a piece wise approach.
Abbreviations: CV, cardiovascular; EAG, External Assessment Group; ICER, incremental cost-effectiveness ratios; N/A, not applicable.	

Table 5. Issue 4. The impact of dapagliflozin on patients' survival

Report section	4.2.6.4
Description of issue and why the EAG has identified it as important	<p>The EAG considers that there is insufficient evidence from the DELIVER trial to substantiate dapagliflozin having an impact on patients' survival compared to SoC; dapagliflozin was [REDACTED] in either CV mortality or all-cause mortality ([REDACTED], respectively).</p> <p>Assuming a CV mortality benefit and the same non-CV mortality for dapagliflozin implicitly assumes a benefit in OS (as all-cause mortality = CV deaths + non-CV deaths). Given the [REDACTED] identified in the overall population, and that a [REDACTED] for CV mortality [REDACTED] with a prior LVEF $\leq 40\%$ (who the EAG's clinical experts consider in practice would continue to be treated as if they have HFrEF, potentially including dapagliflozin as it is already recommended for HFrEF [TA679]), the EAG consider it inappropriate for a CV mortality benefit to be included in the economic model.</p>
What alternative approach has the EAG suggested?	At clarification, the company did not provide requested scenarios where the assumption of a treatment effect of dapagliflozin on CV and all-cause mortality was removed. The EAG has removed the treatment effect of dapagliflozin from CV and all-cause mortality survival curve calculations, for the EAG's base case.
What is the expected effect on the cost-effectiveness estimates?	When a benefit of dapagliflozin on CV and all-cause mortality survival curve calculations is removed from the economic model, the ICER rises from £7,519 to £16,004.
What additional evidence or analyses might help to resolve this key issue?	N/A
Abbreviations: CV, cardiovascular; EAG, External Assessment Group; HFrEF, heart failure with reduced ejection fraction; ICER, incremental cost-effectiveness ratios; LVEF, left ventricular ejection fraction; N/A, not applicable.	

Table 6. Issue 5. Using appropriate NHS reference costs in the economic model

Report section	4.2.8.3, 4.2.8.5
Description of issue and why the EAG has identified it as important	Non-elective in-patient care costs for 20/21 far exceed expected cost increases when looking at previous cost history. Increased costs may be skewed by the COVID-19 pandemic.
What alternative approach has the EAG suggested?	At clarification, the company explored the impact of this by using NHS reference costs from 19/20 inflated to the 20/21 cost year, as requested by the EAG. This assumption forms part of the EAG's base case.
What is the expected effect on the cost-effectiveness estimates?	When NHS reference costs from 19/20 are inflated to the 20/21 cost year and incorporated into the economic model, the company's base case ICER rises from £7,519 to £8,161.
What additional evidence or analyses might help to resolve this key issue?	N/A
Abbreviations: EAG, External Assessment Group; ICER, incremental cost-effectiveness ratios; N/A, not applicable; NHS, National Health Service.	

Table 7. Issue 6. Overestimation of HHF costs in the economic model

Report section	4.2.8.3
Description of issue and why the EAG has identified it as important	Clinical expert opinion outlined hospital LoS following a HHF event as approximately 11 days. At clarification, the company did not provide the mean duration of HHF events observed in DELIVER. Weighted cost codes used to calculate HHF event cost include codes associated with hospital LoS of up to 53 days (EB03A). These are much more expensive and potentially inappropriate given expert opinion.
What alternative approach has the EAG suggested?	At clarification, the company explored the impact of this by using NHS reference costs associated with a shorter LoS, as requested by the EAG. This assumption will form part of the EAG's base case.
What is the expected effect on the cost-effectiveness estimates?	When cost codes relating to a short LoS are incorporated into the economic model, the company's base case ICER rises from £7,519 to £8,466.
What additional evidence or analyses might help to resolve this key issue?	N/A

Abbreviations: EAG, External Assessment Group; HHF, hospitalisation for heart failure; ICER, incremental cost-effectiveness ratios; LoS, length of stay; N/A, not applicable; NHS, National Health Service.

1.4 Summary of EAG's preferred assumptions and resulting ICER

Table 8. EAG's preferred model assumptions

Preferred assumption	Incremental costs	Incremental QALYs	ICER (change from company base case)
Company base case	£1,885	0.251	£7,519
Age adjusted utilities	£1,885	0.238	£7,913 (£394)
Multiplicative population adjusted utilities	£1,885	0.235	£8,006 (£487)
Removal of amputations from adverse events	£2,109	0.247	£8,538 (£1,019)
Non-elective inpatient costs taken from NHS Reference costs 19/20 and inflated to the 20/21 cost year	£2,046	0.251	£8,161 (£642)
HHF disutility applied for 2.75 months	£1,885	0.256	£7,372 (-£148)
6 annual GP visits per year	£1,711	0.251	£6,826 (-£693)
Code cost associated with shorter HHF LoS used	£2,122	0.251	£8,466 (£947)
Removal of dapagliflozin treatment effects from UHFV event calculations	£1,890	0.25	£7,552 (£33)
Removal of dapagliflozin treatment effects from CV and non-CV survival curve calculations	£1,487	0.093	£16,004 (£8,485)

Abbreviations: CV, cardiovascular; EAG, External Assessment Group; GP, general practitioner; HHF, hospitalisation for heart failure; ICER, incremental cost-effectiveness ratio; LoS, length of stay; NHS, National Health Service; QALY, quality adjusted life year; UHFV, urgent heart failure visit.

2 Introduction and background

2.1 Introduction

Herein is a critique of the evidence submitted to the Single Technology Appraisal (STA) in support of the clinical and cost-effectiveness of dapagliflozin (Forxiga[®]; AstraZeneca) in the treatment of symptomatic chronic heart failure (HF) with a left ventricular ejection fraction (LVEF) that is preserved (HFpEF) or mildly reduced (HFmrEF). HFpEF refers to those with an LVEF $\geq 50\%$ and HFmrEF refers to those with an LVEF between 41% and 49%. Treatment with dapagliflozin for patients with symptomatic chronic HF and a reduced LVEF (HFrEF; defined as LVEF $\leq 40\%$ in the National Institute for Health and Care Excellence [NICE] appraisal of dapagliflozin in HFrEF but as LVEF $< 40\%$ in the NICE guideline on chronic HF^{1,2}) has already been recommended by NICE in TA679.¹ The population in the current appraisal is

[REDACTED]

2.2 Background

Within Section B.1 of the company submission (CS), the company provides an overview of:

- dapagliflozin, including its mechanism of action, indications, dose and method of administration (Section B.1.2 of the CS);
- HF, including diagnosis and classification, clinical presentation, epidemiology, disease burden and disease management, with a focus on HFpEF and HFmrEF (Section B.1.3 of the CS).

In this section, the External Assessment Group (EAG) focuses mostly on areas that were commented on by the EAG's clinical experts. For full details provided by the company, see Section B.1 of the CS.

Based on advice from the EAG's clinical experts, the CS presents an accurate overview of HF diagnosis and classification, clinical presentation, epidemiology and disease burden. However, while the discussion of management is largely accurate, the EAG's clinical experts do not agree with the company's statement that HFmrEF and HFpEF are not usually considered as clinically distinct subgroups for the purposes of treatment decisions; they note that those with HFmrEF may be prescribed drugs used to treat those with HFrEF, such as beta-blockers and angiotensin-converting-enzyme inhibitors (ACEi), though this is based on a weaker level of evidence compared to HFrEF and is not included in the NICE guideline for chronic HF for this population.² Evidence for the use of

medications in the HFpEF population is weak, with studies showing non-significant effects on HF outcomes such as hospitalisation for HF (HHF) and cardiovascular (CV) death,³⁻⁸ meaning diuretics are the main drugs used to treat HF symptoms. The company also acknowledge that HFmrEF is considered to be more like HFrEF than HFpEF in terms of pathophysiology.⁹ Therefore, in practice, current treatment options for the HFpEF and HFmrEF groups covered in this appraisal may differ slightly in terms of treating HF symptoms.

The EAG's clinical experts note that, in clinical practice, the group that have previously had LVEF $\leq 40\%$, described in this appraisal as those with an improved LVEF (HFimpEF), would continue to be prescribed treatments for HF that were initiated to treat HFrEF, despite their LVEF now being $>40\%$. The company notes (Section B.2.3.2 of the CS) that clinical guidelines recommend that those with a prior LVEF $\leq 40\%$ continue with treatments initiated for HFrEF. However, they also note, in their response to clarification question A3, that there is a risk that patients may discontinue treatments once LVEF has improved to $>40\%$. The EAG's clinical experts note that this would usually not be the case given LVEF values can fluctuate and the improvement in LVEF could be because the treatments are effective; removing these treatments would, therefore, risk a reduction in LVEF. Given there are no stopping rules for dapagliflozin related to LVEF described in the Summary of Product Characteristics (SmPC),¹⁰ and based on feedback from the EAG's clinical experts, this means it is unlikely that dapagliflozin would be removed from a patient with HFimpEF who had initiated dapagliflozin when they had a reduced LVEF. This means that, in practice, treatment options for the HFimpEF group also differ compared to the HFpEF group.

Diagnosis of HF requires cardiac dysfunction, as well as symptoms and signs of HF (e.g. difficulty breathing, fatigue, oedema), to be present.^{9,11} It is common for those with HF to have comorbidities that may contribute to or interact with HF severity.¹² The EAG's clinical experts note that the HFpEF and, to a lesser extent, HFmrEF groups tend to have more comorbidities than the HFrEF group as, overall, these groups represent an older and more frail population. They note that the high frequency of comorbidities in these groups very often makes diagnosis of HFpEF, in particular, more challenging compared to the HFrEF group. Common comorbidities include other CV-related conditions, such as hypertension, coronary artery disease, atrial fibrillation and chronic kidney disease (CKD), as well as others such as chronic obstructive pulmonary disease and type 2 diabetes mellitus (T2DM).¹³⁻¹⁵ The EAG notes that dapagliflozin is already recommended by NICE for the treatment of some patients with T2DM or CKD (NICE TA288, TA390 and TA418,¹⁶⁻¹⁸ and TA775,¹⁹ respectively), meaning a proportion of those covered in this appraisal may already have an indication for dapagliflozin.

The company state that CKD and T2DM in particular have important implications in terms of patient outcomes and healthcare costs;²⁰⁻²⁹ given that the DELIVER trial stratified for T2DM at randomisation, the EAG requested further subgroup data at clarification (clarification question A1) to assess how T2DM status may have affected outcomes in this trial (see Section 3.3.5.3 for a discussion of results). The same was not requested for CKD status as it was not stratified for at randomisation and there were no concerns from available outcome data (composite outcome in Figure 13 of the CS, and HF events, CV mortality and all-cause mortality reported individually in the clinical study report [CSR]) when split based on baseline estimated glomerular filtration rate (<60 vs ≥60 ml/min/1.73m²) that a difference between subgroups was present.

2.2.1 Positioning of dapagliflozin in the UK treatment pathway

The company explains that current pharmacological treatment for those with HFmrEF or HFpEF typically consists of loop diuretics for HF symptoms and treatments for any comorbidities, which represents standard of care (SoC) for this population.² As mentioned earlier in Section 2.2, while the EAG's clinical experts agree with this for those with an LVEF ≥50% (HFpEF), they note that those with an LVEF between 41% and 49% (HFmrEF) may have some other treatment options that are used for patients with HFrEF. The EAG's clinical experts note that there is a limited evidence base for use of disease modifying drugs in HFmrEF; medications other than diuretics typically have class IIb indications in international guidelines. This class indicates the existence of conflicting evidence and/or a divergence of opinion about the usefulness or efficacy of a treatment recommendations, where usefulness or efficacy of the intervention is less well established by evidence or opinion. It is accepted that an additional, effective disease modifying medication would have considerable value in patients with HFmrEF or HFpEF. The company positions dapagliflozin in this appraisal for use in those with chronic HF and LVEF >40% (HFmrEF or HFpEF) confirmed by a specialist, as an add-on to current SoC (primarily loop diuretics) for HF symptoms.

The company highlights that most patients with HFmrEF or HFpEF are only seen in primary care; either they are not referred to HF specialists or, if referred, may not be provided with a treatment plan upon discharge.³⁰⁻³² A lack of services to support this group of patients are described,³³ and the EAG's clinical experts also note that access to HF specialists is limited and variable across the country, and access to HF specialist nurses is limited.

The company argue that, if recommended, dapagliflozin should be initiated as soon as a diagnosis is made and could be initiated in primary care as long as there is a diagnosis (new or existing) confirmed by a specialist. While the company base this on the clinical experience of prescribing dapagliflozin for other indications in primary care, the EAG's clinical experts stress the importance of a diagnosis of HF with LVEF >40% that is made by a HF specialist. The EAG's clinical experts raised some concern about prescribing in primary care based on historical diagnoses without input from a HF specialist; as HFmrEF/HFpEF is more difficult to diagnose than HFrEF and may be complicated by comorbidities, which are more common within this group, there is uncertainty about the validity of historical diagnoses. This is particularly the case for diagnoses that may not have been made by a cardiologist specialising in HF or where a recent review (i.e., within the last 12 months) that includes assessment of non-CV contributors to symptom burden and the possibility of other diagnoses, and establishment of a holistic treatment plan, has not been performed. The EAG's clinical experts consider that the prescription of dapagliflozin in primary care, without input from a HF specialist at the time of prescription, would only be appropriate if the following criteria were satisfied:

- there is a clear diagnosis of HFpEF or HFmrEF made recently (i.e., within the last 12 months) through a thorough assessment performed by a HF specialist and a holistic treatment plan established as a result. HF specialists could include cardiologists (specifically those with a specialist interest in HF) as well as general practitioners (GPs) or care of the elderly specialists with a specialist interest in HF. The EAG's clinical experts note that this could also be HF specialist nurses but that it may not often be within the remit of a HF specialist nurse;
- the assessment and diagnosis described above should take account of possible non-HF contributors to symptom burden and alternative diagnoses;
- any patients prescribed dapagliflozin solely on a remote basis should be re-evaluated by a HF specialist at some point after prescription;
- ongoing surveillance should occur in primary and secondary care for non-cardiac contributors and risk factors, as for all HF patients.

2.3 Critique of the company's definition of the decision problem

A summary of the final scope issued by NICE,³⁴ together with the company's rationale for any deviation from this, is provided in Table 9. Key differences between the decision problem addressed in the CS and the scope are discussed in greater detail in the sections that follow Table 9, but the EAG notes that in general the decision problem specified by the company matches the NICE final scope well, with the main difference being whether or not treatments for comorbidities are included in the intervention and comparator arms in terms of SoC in the economic modelling.

Table 9. Summary of decision problem

Area of scope	Final scope issued by NICE ³⁴	Decision problem addressed in the submission	Rationale if different from the scope	EAG comment
Population	Adults with symptomatic chronic HF with an LVEF of ≥40%.	<p>Patients with symptomatic chronic HF and an LVEF >40%.</p> <p>This population</p> <p>████████████████████ ████████████████████ ████████████████████ ████████████████████.</p> <p>Diagnosis of HF requires the presence of both cardiac dysfunction, as well as symptoms and signs of HF, such as difficulty breathing, fatigue, ankle swelling, or oedema.^{9, 11}</p>	<p>The EAG notes a minor discrepancy in the LVEF threshold specified in the final scope and that addressed in the decision problem and DELIVER trial (≥40% vs >40%, respectively), which may be because the company states that the current NICE recommendation for dapagliflozin in those with symptomatic HF_{rEF} covers those with LVEF ≤40%.¹</p>	<p>While the EAG notes that HF_{rEF} in the existing NICE recommendation for dapagliflozin may refer to those with an LVEF <40% rather than ≤40%, this is unlikely to have an impact on the conclusions of this appraisal.¹</p> <p>Other than this threshold discrepancy, the EAG consider that main trial in the CS (DELIVER) matches the population described by the company in the decision problem (and the final scope) well.</p> <p>Despite some differences at baseline in the DELIVER trial compared to the population in UK clinical practice that would be eligible for treatment if recommended, the trial is thought to be a reasonable representation of UK practice.</p> <p>The EAG highlights the inclusion of the HF_{impEF} group in DELIVER, which was explored at clarification given this group usually continue to be treated as if they were HF_{rEF} in clinical practice. See Section 2.3.1 below for further discussion.</p>
Intervention	Dapagliflozin in combination with SoC, including loop diuretics and symptomatic treatments for comorbidities.	Dapagliflozin in addition to SoC (comprising loop diuretics, primarily furosemide or bumetanide).	<p>While patients with HF and an LVEF >40% may have multiple varying comorbidities for which they are treated separately, SoC for symptom management of patients with HF and an LVEF >40% in UK clinical practice predominantly comprises treatment with loop diuretics (typically furosemide or bumetanide).³⁵ Therefore, furosemide or</p>	<p>Although the economic analysis does not include the cost of treatments for comorbidities as part of the intervention, patients in the DELIVER trial were receiving treatments for comorbidities as per the NICE final scope. The EAG does not consider this to be an important omission for reasons discussed in Section 2.3.2.</p>

			bumetanide constitute the SoC in the economic analysis for this submission and the composition of SoC is assumed to be the same for both the intervention and the comparator.	The EAG's clinical experts consider the loop diuretics furosemide and bumetanide to accurately reflect SoC for HF symptoms in this population, though they note that those with an HFmrEF or HFimpEF will also in practice have additional options usually used in those with HFrEF. See Section 2.3.2 below for further discussion.
Comparator	Established clinical management without dapagliflozin, including but not limited to loop diuretics and symptomatic treatments for comorbidities.	Placebo in addition to SoC (comprising loop diuretics, primarily furosemide or bumetanide).	As above for SoC components in the economic analysis.	As above for intervention in terms of SoC components included in the economic analysis. See Section 2.3.2 below for further discussion.
Outcomes	The outcome measures to be considered include: <ul style="list-style-type: none"> • symptoms of HF; • hospitalisation for HF; • all-cause hospitalisation; • mortality; • cardiovascular mortality; • kidney function; • adverse effects of treatment; • health-related quality of life. 	As per scope.	N/A	The EAG agrees that all outcomes described in the NICE final scope have been covered in some form in the CS. The EAG's clinical experts consider all important outcomes have been captured in the submission and economic analysis. See Section 2.3.3 below for further discussion.
Economic analysis	<ul style="list-style-type: none"> • The reference case stipulates that the cost effectiveness of treatments should be expressed in terms of incremental cost per QALY. 	<ul style="list-style-type: none"> • The base case cost-effectiveness analysis expresses cost-effectiveness in terms of costs per QALYs 	N/A.	N/A.

	<ul style="list-style-type: none"> • The reference case stipulates that the time horizon for estimating clinical and cost effectiveness should be sufficiently long to reflect any differences in costs or outcomes between the technologies being compared. • Costs will be considered from an NHS and PSS perspective. • The availability of any commercial arrangements for the intervention, comparator and subsequent treatment technologies will be taken into account. 	<p>gained, over a lifetime time horizon.</p> <ul style="list-style-type: none"> • Costs are considered from an NHS and PSS perspective • No commercial discount is included for either the intervention or comparators. 		
Other considerations	<p>The availability and cost of biosimilar and generic products should be taken into account. Guidance will only be issued in accordance with the marketing authorisation. Where the wording of the therapeutic indication does not include specific treatment combinations, guidance will be issued only in the context of the evidence that has underpinned the marketing authorisation granted by the regulator.</p>	<p>The cost of generic products has been considered within the economic analysis as appropriate.</p> <p>The submission population is covered by the anticipated marketing authorisation for dapagliflozin.</p>	N/A.	N/A.

<p>Special considerations, including issues related to equity or equality</p>	<p>No special considerations relating to equity or equality are listed in the NICE final scope.</p>	<p>Equality issues related to the current use of dapagliflozin and limited access to secondary care for patients with HF and an LVEF >40%.</p>	<p>Dapagliflozin is currently available across primary and secondary care treatment settings for patients with HFrEF,¹ T2DM,¹⁶⁻¹⁸ and CKD.^{10, 19} Initiation of dapagliflozin for the treatment of patients with HF and an LVEF >40% in the primary care setting would improve equality of access to dapagliflozin without relying on access to specialist care, which is limited to only a few HF centres commissioning services to support patients with HF and an LVEF >40% after diagnosis, or offering specialised HFpEF clinics alongside their usual HF services.³³</p> <p>Given the substantial clinical experience in the prescribing of SGLT2 inhibitors in primary care, AstraZeneca firmly believes that there is no clinical rationale for specifically restricting access to dapagliflozin for patients with HF and an LVEF >40% by requiring specialist review before making the treatment recommendation. As in the case of HFrEF, it is important to ensure that diagnosis of HF, including associated LVEF %, is clinically confirmed by a specialist, but once that diagnosis is known or if it is already determined, initiation of treatment with dapagliflozin should be in either primary or secondary care. This should be easily implementable given that most HF services are already organised across primary and secondary care and that</p>	<p>The EAG's clinical experts stress the importance of a diagnosis of HF with LVEF >40% (HFpEF or HFmrEF) that is made by a specialist if dapagliflozin were to be prescribed in primary care without further specialist input. There is some concern about prescribing in primary care based on historical diagnoses.</p> <p>As HFpEF/HFmrEF is more difficult to diagnose than HFrEF and may be complicated by comorbidities, which are more common within this group, there is uncertainty about the validity of historical diagnoses. This is particularly important where the diagnosis may not have been made by a cardiologist specialising in HF or where a recent review with a specialist (i.e., within the last 12 months) including assessment of non-CV contributors to symptom burden and potential other diagnoses, and establishment of a holistic treatment plan, has not been performed. See Section 2.2.1 for further discussion.</p>
---	---	---	--	---

			dapagliflozin does not require up-titration nor specific monitoring over and above what is recommended for a patient with HF already. In addition, enabling the treatment of patients with dapagliflozin within primary care will support the NHS with its COVID-19 recovery plans by reducing both waiting times to outpatient services and unnecessary specialist referrals, minimising unwarranted variations in care for HF patients across England and Wales.	
Subgroups to be considered	N/A.	N/A.	N/A.	<p>The EAG requested at clarification that results for certain subgroups for outcomes other than the composite outcome are provided, such as HHF and UHFV which are included in the economic model.</p> <p>This was requested for subgroups thought to be potentially important, including LVEF groupings, history of prior LVEF $\leq 40\%$ and T2DM. Based on these data, the EAG considers it reasonable for the company to focus on the overall population, but some observations provide further rationale for decisions made in relation to the EAG's base case of the economic model.</p> <p>See Section 2.3.4 below for further discussion.</p>

Abbreviations: CKD, chronic kidney disease; CS, company submission; EAG, External Assessment Group; HF, heart failure; HFimpEF, heart failure with improved ejection fraction; HFmrEF, heart failure with mildly reduced ejection fraction; HFpEF, heart failure with preserved ejection fraction; HFrEF, heart failure with reduction ejection fraction; HHF, hospitalisation for heart failure; LVEF, left ventricular ejection fraction; N/A, not applicable; NHS, National Health Service; NICE, The National Institute for Health and Care Excellence; PSS, Personal Social Services; QALY, quality-adjusted life year; SGLT2, sodium-glucose-co-transporter-2; SoC, standard of care; T2DM, type 2 diabetes mellitus; UHFV, urgent heart failure visit.

2.3.1 Population

While there is a slight discrepancy in how HFrEF is defined by the company in this submission (LVEF $\leq 40\%$) compared to the NICE final scope (includes those with $\geq 40\%$ as HFmrEF or HFpEF, rather than those with an LVEF of 40% being considered as HFrEF)³⁴ and the NICE guideline on chronic HF (defines HFrEF as LVEF $< 40\%$),² the EAG is not concerned that this will affect the conclusions of the appraisal. There is variation across guidelines in terms of distinguishing between HFrEF and HFmrEF/HFpEF; while the NICE guideline defines HFrEF as an LVEF $< 40\%$, the European Society of Cardiology (ESC) guidelines defines it as LVEF $\leq 40\%$,⁹ and the key trial focused on in the NICE appraisal of dapagliflozin in HFrEF included those with LVEF $\leq 40\%$.³⁶ The EAG's clinical experts also note that while LVEF thresholds are useful, they can be quite arbitrary, particularly if values are only just above the 40% threshold as these patients may be similar to those recording values under 40% and there may be fluctuation for an individual patient. This is one reason why in UK practice some patients with HFmrEF may receive other treatments usually used in the HFrEF population, with the other being that there is some lower-level research evidence for benefit in a HFmrEF population.

Other than the threshold discrepancy in the DELIVER trial for HFmrEF or HFpEF (defined as $> 40\%$) vs the NICE final scope, this trial, which is the main focus of the CS, matches the population in the final scope well; it was limited to adults aged ≥ 40 years (considered reasonable by the EAG's clinical experts as the majority of the population in practice would be older than this and the cause of HFmrEF or HFpEF in those < 40 years would likely differ to most patients), there are reasonable inclusion criteria to ensure only symptomatic patients are included and the requirement for symptom/sign duration for at least six weeks helps to ensure only chronic HF patients are included. Measurement of LVEF was also performed using appropriate methods, such as echocardiography. The EAG's clinical experts note that while the trial only included those ≥ 40 years old, they would not be against dapagliflozin (if recommended) being considered in those < 40 years old on an individual patient basis. The EAG notes that age is not a restriction in the SmPC.¹⁰ However, a lack of safety data in pregnancy/breastfeeding is also highlighted by the EAG's clinical experts for women of childbearing age, which can include women over 40 years of age.

The EAG's clinical experts note some differences at baseline for the trial population in DELIVER relative to UK practice, as follows:

- use of treatments other than diuretics, such as mineralocorticoid-receptor antagonists (MRAs), ACEi, angiotensin receptor blockers (ARBs) and beta-blockers – proportions in the trial are higher for some treatments than would be expected for this population in clinical practice (for example, ~20% MRA and ~50% ACEi/ARB/angiotensin receptor neprilysin inhibitor (ARNI) would be expected vs ~█% and ~█%, respectively, in the trial);
- mean age in the trial is slightly lower than would be expected in practice (~72 years vs 75-80 years);
- ethnicity breakdown will vary across the UK, but it is possible that a higher proportion of Black or Asian patients would be seen in practice;
- a higher proportion of New York Heart Association (NYHA) class III patients might be expected in practice.

However, in general, the trial is thought to be a reasonable representation of the UK population (a scenario analysis using UK Clinical Practice Research Datalink data for baseline characteristics in the economic model (see Section 4.2.2 of this report) was also performed by the company to assess any impact on cost-effectiveness (Sections B.3.3.2 and B.3.10.3 of the CS). The biggest difference highlighted was for the use of some treatments other than loop diuretics. This may partially be explained by the clinical trial setting, for example, populations in clinical trials may be slightly better treated (e.g., for comorbidities) than in current practice.

The difference in terms of use of treatments other than loop diuretics may also be explained by the inclusion of the HFimpEF group in the trial. This group is defined as those who have previously had an LVEF of $\leq 40\%$ that has since improved to be $>40\%$ and comprised ~18% of the overall trial population in DELIVER. The EAG's clinical experts confirm that in practice, this group would continue on treatments established when they were HFrEF, which might also include dapagliflozin in addition to SoC if this has already been initiated in practice (the EAG note that to be included in the DELIVER trial, participants could not have been treated with an SGLT2 inhibitor within 4 weeks prior to randomisation or have previous intolerance to an SGLT2 inhibitor). As noted above in Section 2.2.1, while the company acknowledge this in the CS, they also note in response to clarification question A3 that there is a risk that patients may discontinue treatments initiated for HFrEF once LVEF has improved to $>40\%$. As the HFimpEF group, based on clinical expert feedback, has more SoC options compared to those that haven't previously been classed as HFrEF, and as █

█, the EAG explored

this at the clarification stage by requesting the results for this subgroup for additional outcomes (clarification questions A1 and A2; see Section 3.3.5.1 for further details).

In response to clarification question A14, the company note that data is not available to provide a breakdown of patients taking drugs other than loop diuretics for comorbidities vs those taking them for HF symptoms specifically.

2.3.2 Intervention and comparator

The intervention in the CS is oral dapagliflozin (brand name Forxiga®), matching the NICE final scope,³⁴ to be used at a dose of 10 mg once daily. A summary is provided in Table 2 of the CS. The dose used in the DELIVER trial was in line with this. Marketing Authorisation

[REDACTED]

The only difference between the NICE final scope³⁴ and the company's description of the intervention and comparator in the decision problem is the description of the SoC component, which is to be used in combination with dapagliflozin if recommended. While the scope includes treatments for comorbidities under SoC, the company only includes treatments specific for HF symptoms (in this case said to be the loop diuretics, furosemide or bumetanide, in the HFpEF/HFmrEF population) and not treatments for comorbidities in the economic model. The EAG notes that while this is the case in the economic analysis, where comorbidity treatments have not been costed for, the trial itself does allow treatments for comorbidities. The EAG does not consider the lack of costing for comorbidity treatments to be an important omission for the following reasons:

- use of these treatments should be the same for each treatment arm and should not be affected by dapagliflozin use;
- although a survival benefit for dapagliflozin is included in the economic model and used by the company in their base case, the difference in CV and non-CV mortality events between the groups in the model [REDACTED] (~ [REDACTED] CV mortality events but ~ [REDACTED] non-CV mortality events in the [REDACTED]). The lack

of costing for comorbidities is, therefore, unlikely to impact cost-effectiveness unless costs are very high;

- the EAG also considers that no survival benefit for dapagliflozin should be included in the economic model, which forms part of the EAG's base case and means costing for comorbidities is unlikely to affect cost-effectiveness.

The EAG's clinical experts agree that in practice, for the population with HFpEF or HFmrEF, loop diuretics are the most commonly used SoC option to treat HF symptoms. They also agree that this is usually either furosemide or bumetanide and they are options for all patients with HFpEF or HFmrEF. Although the HFimpEF group (as noted above in Section 2.3.1) usually continue to be treated as if they are HFrEF and therefore in practice may have other treatments as part of their SoC (such as beta-blockers or ACEi), given the reasons described above for comorbidity treatments also apply here, the EAG is not concerned about their omission from the economic modelling.

Similarly, for the group with HFmrEF included in the trial, while the EAG's clinical experts note that in practice they may have access to some additional SoC treatments that are more commonly used for patients with HFrEF, this is based on a lower level of evidence and may vary. It is anticipated that most with HFpEF or HFmrEF using additional treatments (other than loop diuretics) would be using them for comorbidities rather than HF symptoms specifically. In response to clarification question A14, the company confirmed that a breakdown of the proportion that were taking additional treatments for HF symptoms specifically could not be provided as this data was not captured in the DELIVER trial. As the proportion using treatments other than loop diuretics as part of their SoC for HF symptom treatment is anticipated to be low, in addition to the same reasons described above for comorbidity treatments, the EAG does not consider the lack of costing for these additional SoC treatments in the economic analysis to be an important omission.

2.3.3 Outcomes

The EAG notes that all outcomes specified in the NICE final scope³⁴ have been covered in some form in the CS. The primary endpoint in the DELIVER trial is a composite of CV mortality and HF events (HHF or urgent heart failure visit [UHFV]) requiring diuretic therapy; however, the economic analysis instead uses individual outcomes. While the individual outcomes are reported in the CS in the overall trial population, the EAG requested at clarification (clarification questions A1 and A2) that results for these outcomes be provided for some of the subgroup analyses thought to be important to explore (see Sections 2.3.4 and 3.3.5 below).

The EAG's clinical experts consider that all important outcomes are included in the submission and economic analysis. For example, they are not concerned that any important adverse events have been omitted from the economic analysis.

2.3.4 Subgroups

Although no subgroup analyses were specified in the NICE final scope,³⁴ the EAG requested further outcome data for certain subgroups included in the CS, including LVEF groupings, history of prior LVEF $\leq 40\%$ and T2DM (clarification questions A1 and A2). The request included results for outcomes other than the composite outcome, such as HHF and UHFV. For the first two subgroups, this was because SoC options are thought to differ slightly among these subgroups meaning there is a possible clinical rationale for results differing. Additional subgroup results for the T2DM categories were also requested as the DELIVER trial was stratified for this at randomisation and the company comment in the CS that it is possible T2DM status may affect outcomes (Section B.1.3.2 of the CS).

On reviewing this additional data, the EAG concludes that the company's use of the overall full analysis set from the DELIVER trial in the CS and economic model is reasonable. Although for certain outcomes there are [REDACTED] subgroups in terms of the [REDACTED] of dapagliflozin [REDACTED], the EAG notes that in most cases conclusions across subgroups are [REDACTED]. In addition, where differences in point estimates are larger between subgroups, this was only for certain outcomes and there was not a consistent pattern across all outcomes reported. Some subgroup results do, however, provide further rationale for some of the decisions made in relation to the EAG's base case. Subgroup results are discussed in more detail in Section 3.3.5.

Based on data in the CS and CSR, the EAG also asked the company to clarify the likely rationale for larger differences in specific outcomes for certain subgrouping strategies, including systolic blood pressure categories, groups based on median body mass index and [REDACTED] (clarification question A4). Based on the company's response to clarification and feedback from the EAG's clinical experts, the EAG is not concerned that these subgroups are likely to be linked to any differences in treatment efficacy that could affect the conclusions of the appraisal, but results for one subgroup do provide further rationale for one of the decisions made in relation to the EAG's base case. These results are discussed further in Section 3.3.5.4 and Appendix 8.1.

3 Clinical effectiveness

3.1 Critique of the methods review

The company conducted a systematic literature review (SLR) to identify randomised controlled trials (RCTs) of treatments for patients with chronic heart failure (HF) and a left ventricular ejection fraction (LVEF) >40%, including HF with mildly reduced LVEF (HFmrEF) and HF with preserved LVEF (HFpEF). The SLR was conducted according to best practice guidance provided by Cochrane, and reported according to the guidance provided by the National Institute of Health and Care Excellence (NICE), and the Preferred Reporting Items for Systematic Reviews and Meta-Analyses (PRISMA) guidelines.^{37, 38} Methods and results of the SLR are described in detail in Appendix D of the company submission (CS) and the External Assessment Group (EAG)'s critique is presented in Table 10 below.

The original SLR conducted in August 2018 was broad enough to include various treatments in those with HF and LVEF >40%, including sodium-glucose-co-transporter-2 (SGLT2) inhibitors such as dapagliflozin, loop diuretics, angiotensin-converting enzyme inhibitors (ACEi), angiotensin receptor blockers (ARBs) and beta-blockers. However, inclusion criteria for this appraisal were narrower than this as the company describe in Section B.1.1 of the CS that placebo in addition to standard of care (SoC) is the only relevant comparator to dapagliflozin in this population. As in UK practice SoC in this population primarily consists of loop diuretics (e.g., furosemide or bumetanide), only studies conducted in patients receiving either dapagliflozin or loop diuretics were therefore included in the updated SLR that was performed in June 2022.

In total, four studies in those with HF and an LVEF >40% receiving either dapagliflozin or loop diuretics were identified. Two of these provided direct clinical evidence for the efficacy and safety of dapagliflozin in combination with SoC compared to SoC only (DELIVER and PRESERVED-HF),³⁹⁻⁴² but the CS focused on DELIVER and this trial was the only one used to inform the economic model, which the EAG agrees is appropriate for reasons described in Section 3.2. A critique of the DELIVER trial is also provided by the EAG in Section 3.2.

The other two studies highlighted in the CS (DROP-PIP and J-MELODIC) were studies comparing different loop diuretics to each other and did not contain a dapagliflozin arm, meaning they were not relevant to the appraisal.^{43, 44}

In addition to the aforementioned RCTs, as described in Section 3.2, the CS also describes a UK Clinical Practice Research Datalink (CPRD) dataset that was used to inform baseline characteristics

for a scenario in the economic model as an alternative to those from the DELIVER trial (Sections B.3.3.2 and B.3.10.3 of the CS).⁴⁵ The EAG considers its use in a scenario analysis for baseline characteristics to be reasonable, despite limitations described for collection of symptomatic status in response to clarification question A10.

Table 10. Summary of the EAG’s critique of the methods implemented by the company to identify evidence relevant to dapagliflozin use in HF with LVEF >40%

Systematic review step	Section of CS in which methods are reported	EAG’s assessment of robustness of methods
Data sources	Appendix D.2.1	<p>The EAG considers the sources and dates searched to be comprehensive.</p> <p>Databases searched:</p> <ul style="list-style-type: none"> Embase; MEDLINE; the Cochrane Database of Systematic Reviews (CDSR); the Cochrane Controlled Register of Trials (CENTRAL); Database of Abstracts of Reviews of Effects (DARE). <p>Registries:</p> <ul style="list-style-type: none"> ClinicalTrials.gov <p>Conference proceedings:</p> <ul style="list-style-type: none"> ACC; AHA; BCS; ESC; HFA of ESC Heart Failure Congress; Major cardiology conferences from the last two years (i.e., 2020 to 2022) were manually hand-searched in July 2022. The exclusion of abstracts from conferences prior to 2020 was justified under the assumption that high-quality research would since have been published in a peer-reviewed journal: <p>Other Grey Literature:</p> <ul style="list-style-type: none"> Manual reference list searches of relevant SLRs and NMAs. <p>The updated SLR relevant to this appraisal was performed in June 2022. Search strategies were date limited to 1st January 2013 onwards, as it was not considered that any studies identified prior to this date would represent relevant SoC. The EAG’s clinical experts thought this was a reasonable cut-off date.</p>
Search strategies	Appendix D.2.1	<p>The EAG is satisfied that the company’s searches have identified all evidence relevant to the decision problem.</p> <p>The search strategies for the literature review used free-text keywords, medical subject headings (MeSH) and Emtree terms for the population and interventions of interest, along with the validated RCT filter by SIGN.⁴⁶</p>
Inclusion criteria	Appendix D.2.2	<p>The EAG considers it unlikely that relevant evidence was excluded based on the eligibility criteria used.</p> <p>The eligibility criteria (Table 10 of CS appendices) matched, or were broader than (e.g., in terms of outcomes), the target population, intervention, comparator and outcomes described in the NICE final scope. Records were limited to English language studies and studies published in or after January 2013.</p> <p>It is unclear whether outcomes were used to screen articles for inclusion at the title and abstract stage; if so, it is possible relevant studies could have been</p>

		<p>excluded as not all outcomes may be reported in the title and abstract. The EAG considers it unlikely, however, that any relevant studies for dapagliflozin in the relevant population have been missed.</p> <p>A reference list of all records excluded at full text review is provided in Table 12 of the CS appendices.</p>
Screening	Appendix D.2.2	<p>The EAG considers the reporting of methods for screening to be adequate.</p> <p>Records were dual screened at both the abstract and full text review stage. Results were compared and any disagreements were resolved by discussion until a consensus was met. If necessary, a third independent reviewer made the final decision.</p>
Data extraction	Appendix D.2.2	<p>The EAG considers data extraction procedures to be appropriate.</p> <p>Data extraction using prespecified data extraction tables in Microsoft Word® was conducted on two dapagliflozin studies (DELIVER and PRESERVED-HF) that were finally included in the SLR for this submission. Data extraction was conducted by two researchers (one primary extractor and a second quality check reviewer). Any disagreements were resolved by discussion and involvement of a third independent reviewer if consensus could not be reached.</p>
Tool for quality assessment of included study or studies	Appendix D.2.2	<p>The EAG agrees with the company's choice of quality assessment tool of RCTs.</p> <p>The company used an appropriate method to assess the quality of the included RCTs and provided justification for each of the quality assessment answers. The tool developed by the University of York's CRD was used,⁴⁷ with each quality assessment completed by one individual and verified by a second individual.</p> <p>The EAG's assessment of the DELIVER trial, which was the focus of the CS and economic model, is presented in Section 3.2.</p>

Abbreviations: ACC, American College of Cardiology; AHA, American Heart Association; BCS, British Cardiovascular Society; CRD, Centre for Reviews and Dissemination; CS, company submission; EAG, External Assessment Group; ESC, European Society of Cardiology; HFA, Heart Failure Association; NICE, The National Institute of Health and Care Excellence; NMA, network meta-analysis; RCT, randomised controlled trial; SLR, systematic literature review; SIGN, Scottish Intercollegiate Guidelines Network; SoC, standard of care.

3.2 Critique of trials of the technology of interest

As discussed above in Section 3.1, two RCTs of dapagliflozin vs placebo are mentioned in the CS for the population relevant to this appraisal (HFmrEF or HFpEF). The company focuses on the DELIVER trial^{39, 40} as the primary source of clinical evidence and uses data from this trial in the economic model, while the PRESERVED-HF trial^{41, 42} is also presented but not as a focus of the submission. Details of the methods employed in these two RCTs are provided in Sections B.2.3 and B.2.11 of the CS. A quality assessment of both trials was provided by the company (Table 10 of the CS for DELIVER and Table 15 of the CS appendices for PRESERVED-HF).

The company's reasoning for only using the DELIVER trial to inform the economic analysis (see Section B.2.2 of the CS) is that the PRESERVED-HF trial:

- is smaller (n=324 patients vs n=6263 patients in PRESERVED-HF compared to DELIVER);
- uses of an LVEF threshold $\geq 45\%$ for inclusion in the trial (narrower than the DELIVER trial, which includes LVEF $>40\%$);
- has a shorter trial duration of 12 weeks (median follow-up of [REDACTED] in DELIVER);
- the primary focus is on HF disease-specific health status outcomes as measured on the Kansas City Cardiomyopathy Questionnaire Clinical Summary Score (KCCQ-CSS) rather than outcomes such as hospitalisation for heart failure (HHF) or urgent heart failure visits (UHFV).

The EAG consider this rationale to be reasonable and also highlights that the two arms in the PRESERVED-HF trial are less well-matched at baseline compared to the DELIVER trial; for example, the proportion with a previous HHF or using certain types of medications at baseline, including mineralocorticoid receptor antagonists, loop diuretics and anticoagulant agents, is noticeably different between the two treatment arms (see Table 20 of the CS). The EAG provides a critique of the internal validity of the DELIVER trial in detail below, including the design, conduct and analysis. Overall, the EAG agrees with the company's critique and has no major concerns, particularly for the primary outcome.

In addition to the RCTs, the CS also describes a UK CPRD dataset in Section B.3.3.2 of the CS,⁴⁵ which was used as a scenario for baseline characteristics in the economic analysis (Section B.3.10.3 of the CS). The EAG considers its use in a scenario analysis for baseline characteristics to be reasonable, despite limitations described for collection of symptomatic status in response to clarification question A10. No outcomes were collected as part of this dataset and its use was, therefore, limited to this scenario analysis for baseline characteristics.

Table 11. A summary of the EAG's critique of the design, conduct and analysis of the DELIVER trial

Aspect of trial design or conduct	Section of CS in which information is reported	EAG's critique
Randomisation	Tables 7 and 10 of the CS, and Section 9.4.3 of the CSR	<p>Some concerns about capping</p> <p>Randomised 1:1 using an IWRS in balanced blocks. Randomisation was stratified by T2DM status at baseline ([REDACTED]).</p> <p>[REDACTED]</p> <p>[REDACTED]</p> <p>[REDACTED]</p> <p>[REDACTED]</p> <p>[REDACTED] However, the EAG's clinical experts consider the proportion with specific comorbidities in the DELIVER trial, including atrial fibrillation, to be reasonable relative to UK practice.</p>
Concealment of treatment allocation	Table 10 of the CS and Table 1 of the CSR	<p>Appropriate</p> <p>While it is unclear whether the randomisation schedule was kept by a third party, this is likely as a third party was described as being responsible for the set-up and maintenance of the IWRS for randomisation and drug dispensation.</p>
Eligibility criteria	Table 7 of the CS	<p>Appropriate</p> <p>Inclusion criteria of the trial match the population described in the decision problem well. Limiting to adults ≥ 40 years is not thought to be a concern by the EAG's clinical experts as most patients with HFmrEF or HFpEF are older than this.</p>
Blinding	Tables 7 and 10 of the CS	<p>Appropriate</p> <p>The trial was described as being double-blind. Patients, investigators and the adjudication committee were blind to treatment assignment. The IWRS was said to have managed study agent inventory while ensuring that no one at the sites needed to be unblinded. Dapagliflozin and placebo treatments are also described as matching.</p>
Baseline characteristics	Table 8 of the CS	<p>Well-balanced between groups</p>

		<p>Baseline characteristics for the FAS population are well-balanced between dapagliflozin and placebo groups, including demographics, HF history, comorbidities and SoC/comorbidity treatments. This was also the case for [REDACTED]</p> <p>Applicability of the baseline characteristics in the trial to the decision problem and UK practice is discussed in Section 2.3.1.</p>
Dropouts	Table 10 and Figure 6 of the CS, and Sections 2, 11.1.1.1 and 11.1.2.2 of the CSR	<p>Balanced between groups, low rate for primary outcome</p> <p>Of those randomised, missing data was said to be an issue for very few patients as for the primary endpoint (composite of time to first CV death, HHF or UHFV) complete follow-up was described for [REDACTED] in dapagliflozin and placebo groups, respectively. Complete follow-up for this outcome was those with a primary event or who were censored due to non-CV death or at PACD in the analysis. PACD was the date at which study closure procedures were initiated after the predetermined number of adjudicated primary events (n=1117) were predicted to have occurred.</p> <p>At 8 months, KCCQ-TSS missing data (of those with data available at baseline) was similar between the two treatment groups but [REDACTED] missing due to death and, of those that were alive at 8 months, [REDACTED] with missing due to other reasons, in the dapagliflozin and placebo groups, respectively).</p>
Statistical analysis		
Sample size and power	Table 9 of the CS	<p>Appropriate</p> <p>The study was event driven. In the FAS population, n=1117 events for the composite outcome were estimated to provide 90% power, assuming a HR of 0.80 between dapagliflozin and placebo. This was originally n=844 but was updated when [REDACTED] was decided upon. A total of n=1122 events were observed in the primary end-point analysis.</p> <p>The assumed HR of 0.80 was chosen as a conservative assumption based on previously observed HRs in EMPA-REG and CANVAS studies,^{48, 49} as the HRs in the studies themselves were based on <i>post-hoc</i> subgroup analyses with limited documentation of baseline HF diagnosis and not characterised by LVEF.</p> <p>Event rate assumptions used to estimate required sample size to observe the required number of events were based on subgroup analyses of TOPCAT and I-PRESERVE studies, relevant to the group with HF and an LVEF >40% and NT-proBNP ≥300 pg/ml. An original sample size of 4700 randomised patients for n=844 primary events was adapted to obtain the increased target number of n=1117 primary events based on ongoing blinded monitoring of event accrual. Sample size was increased from 4700 to 6100, which was met in the trial as n=6263 were randomised.</p>
Analysis for estimate of effect	Section B.2.4 of the CS and Table 9 of the CSR	<p>Appropriate</p>

		<p>Analyses for primary and secondary endpoints were performed in the FAS population, defined as all of those randomised, irrespective of their protocol adherence and continued participation in the study. They were analysed according to randomised treatment assignment, irrespective of treatment actually received. Figure 6 in the CS shows that [REDACTED] did not receive any dose of treatment ([REDACTED] of those randomised) and [REDACTED] patients ([REDACTED] of those randomised) discontinued treatment, with similar proportions (and reasons for treatment discontinuation) in both arms.</p> <p>Analyses of adverse events were performed in the SAS, which included those randomised that received at least one dose of treatment. Only [REDACTED] in each arm did not receive a single dose of treatment. All others were included in the analysis ([REDACTED] in dapagliflozin + SoC vs SoC groups, respectively) and received the treatment they were randomised to.</p> <p>KCCQ-TSS outcomes presented in the CS were analysed in the overall group with all randomised patients. Sensitivity analyses are described in the CSR, where the focus is on the group that had their 8-month assessment planned or performed prior to 11 March 2020, when COVID-19 was declared a pandemic. No effect of different time periods in relation to the COVID-19 pandemic was identified (Tables 32, 33, 35 and 36 in the appendix of the company's clarification responses), which is why the CS focuses on the whole population.</p>
Handling of missing data	Table 10 and Figure 6 of the CS, Table 14.2.4.2 of the CSR	<p>Appropriate</p> <p>For event-based outcomes, such as the primary composite outcome, missing data is described as being low. Patients were censored at the last clinical event assessment and follow-up was good as described in Figure 6, with [REDACTED] having unknown vital status.</p> <p>For KCCQ-TSS outcomes, missing data for those alive at 8 months was [REDACTED] in the dapagliflozin and placebo groups, respectively ([REDACTED] with baseline KCCQ-TSS data died before 8 months). Missing values (for reasons other than death)</p> <p>[REDACTED]</p> <p>[REDACTED]</p> <p>[REDACTED]</p> <p>[REDACTED]</p> <p>[REDACTED]</p> <p>[REDACTED]</p>
Outcome assessment	Section 9.7 of the CSR	<p>Appropriate</p> <p>[REDACTED]</p> <p>[REDACTED]</p> <p>[REDACTED]</p>

		<p>[REDACTED]</p> <p>[REDACTED]</p> <p>Thresholds used for KCCQ-TSS improvements or deterioration in the CS</p> <p>[REDACTED]</p> <p>[REDACTED] The thresholds used in the CS are in line with those reported</p> <p>[REDACTED] and the EAG's clinical experts consider them to be reasonable thresholds for determining whether improvements or deteriorations are clinically significant.³⁶</p>
--	--	--

Abbreviations: CEA, Clinical Events Adjudication; CS, company submission; CSR, clinical study report; CV, cardiovascular; EAG, External Assessment Group; FAS, full analysis set; HbA1c, haemoglobin A1c; HF, heart failure; HFmrEF, heart failure with mildly reduced ejection fraction; HFpEF, heart failure with preserved ejection fraction; HHF, hospitalisation for heart failure; HR, hazard ratio; IWRS, interactive web-response system; KCCQ-TSS, Kansas City Cardiomyopathy Questionnaire – Total Symptom Score; LVEF, left ventricular ejection fraction; NT-proBNP, N-terminal pro B-type natriuretic peptide; NYHA, New York Heart Association; PACD, primary analysis censoring date; SAS, safety analysis set; SoC, standard of care; T2DM, type 2 diabetes mellitus; UHFV, urgent heart failure visit.

3.3 Critique of the clinical effectiveness analysis

In the CS, the company focuses on data from the full analysis set (FAS) in the DELIVER trial in terms of clinical effectiveness results. For reasons described in Section 3.2, the EAG agrees with the decision to focus on the DELIVER trial and not the PRESERVED-HF trial or pooled results from the two.

At the clarification stage, the EAG requested further outcome data for certain subgroups (clarification questions A1 and A2) to assess whether any differences in clinical efficacy between these groups were observed and whether use of the FAS in the overall population is appropriate. Based on the company's response to this, which is discussed in more detail in Sections 2.3.4 and 3.3.5, the EAG agrees that use of the FAS in the overall population is appropriate. A brief outline of the results for the overall FAS population (Sections 3.3.1 to 3.3.4) and the subgroups further data were requested for at clarification (Section 3.3.5) are presented in this section. The EAG focuses mostly on outcomes feeding into the economic model.

In Section 3.3.5.4 and Appendix 8.1, the EAG comments on the company's response to clarification question A4 in terms of the rationale provided to explain certain larger differences between other subgroup strategies mentioned in Section 2.3.4.

The EAG notes that there is no indirect treatment comparison included in the CS as there is direct evidence for dapagliflozin + SoC compared to SoC, the only comparator of interest described in the decision problem and NICE final scope.³⁴

3.3.1 *Heart failure events, mortality and hospitalisation*

Results for various HF and mortality outcomes reported in the CS for the DELIVER trial are presented in Table 12 below for the overall FAS population. The EAG notes that the composite outcome of cardiovascular (CV) mortality and HF events (HHF and UHFVs) was the primary outcome in the DELIVER trial. As individual outcomes (CV mortality, all-cause mortality, HHF and UHFVs) were used to inform the economic model rather than a composite, results for these from the DELIVER trial are also presented. All-cause hospitalisation is also presented for information, although it was not one of the outcomes included in the economic model. See Section B.2.6 of the CS for all endpoints that were mentioned in the submission.

The EAG notes that a statistically significant effect of dapagliflozin in reducing the composite outcome of CV mortality and HF events, [REDACTED] was observed; however, while the point estimates [REDACTED] [REDACTED] were identified for CV death, UHFV, all-cause mortality and all-cause hospitalisation. This table also indicates that of all deaths, >45% were CV-related in both arms.

Two sensitivity analyses for the primary composite outcome were described as being consistent with the results for the main analysis. This included one where [REDACTED]

[REDACTED] and included as endpoint events,⁴⁰ and another where patients were censored at the onset of the first adverse event (AE) associated with COVID-19 infection.³⁹ The EAG agrees that they are consistent with the main analysis.

Table 12. Proportion with events in each arm and HRs for dapagliflozin + SoC vs. SoC in the overall FAS population of the DELIVER trial (adapted from Table 11 of the CS)

Outcome – median follow-up [REDACTED]	Dapagliflozin + SoC n/N (event rate)	Placebo + SoC n/N (event rate)	HR (95% CI; p-value)
Composite of CV mortality and HF events	[REDACTED]	[REDACTED]	0.82 (0.73 to 0.92; p=[REDACTED])
CV mortality	231/3131 [REDACTED]	261/3132 [REDACTED]	0.88 (0.74 to 1.05; p=[REDACTED])
HF event	[REDACTED]	[REDACTED]	[REDACTED]
HHF	[REDACTED]	[REDACTED]	[REDACTED]
UHFV	[REDACTED]	[REDACTED]	[REDACTED]
All-cause mortality	497/3131 (NR)	526/3132 (NR)	0.94 (0.83 to 1.07; p=[REDACTED])
All-cause hospitalisation	[REDACTED]	[REDACTED]	[REDACTED]

Abbreviations: CI, confidence interval; CV, cardiovascular; HF, heart failure; HHF, hospitalisation for heart failure; HR, hazard ratio; SoC, standard of care; T2DM, type 2 diabetes mellitus; UHFV, urgent heart failure visit.

[REDACTED]

The hierarchical testing sequence stopped before the endpoint of time to death from any cause could be assessed. The analysis of this endpoint was, therefore, not conducted as part of the confirmatory testing sequence. All-cause hospitalisation was an exploratory endpoint that was not part of the hierarchical testing sequence.

3.3.2 Quality of life

3.3.2.1 Kansas City Cardiomyopathy Questionnaire

Quality of life was primarily assessed in the DELIVER trial using the disease-specific Kansas City Cardiomyopathy Questionnaire (KCCQ). Of the various summary scores available, the company focus on the Total Symptom Score (KCCQ-TSS) in the CS, which was prespecified as a secondary endpoint in the trial and is the same measure used for the appraisal in HF with reduced LVEF (HFrEF; TA679).¹ Scores are transformed to a 0 to 100 scale, with higher values indicating better health status.

As indicated in Table 14 of the CS for all randomised patients with data available, when compared with placebo using a repeated measured mixed-effects model, a

████████████████████ in mean (95% confidence interval [CI]) change from baseline KCCQ-TSS score, favouring dapagliflozin, was observed at 8 months (2.4, 1.5 to 3.3;

██████████; a change from baseline score

████████████████████

██████████, was observed for dapagliflozin and placebo arms). While a

████████████████████ between arms was observed, it is unclear whether the difference between arms observed is clinically meaningful. ██████████ were made at

months 1 and 4, although it is

████████████████████

██████████ The ██████████ observed informed the company's decision to use treatment-specific transition probabilities between KCCQ-TSS quartiles in the economic model (see Section 4.2.4 and 4.2.6.1 for further details).

In the CS, n=██████████ were said to have had baseline KCCQ-TSS data available; however, the EAG notes that in the clinical study report (CSR) this appears to be n=██████████. Mean [SD] values at baseline were ██████████ for the two arms (██████████ vs ███████████ for dapagliflozin and placebo, respectively, with n=██████████ and n=██████████ analysed, according to the CSR). Based on data from the CSR, of those that were alive at 8 months (n=██████████ and n=██████████ for dapagliflozin and placebo groups, respectively), ██████████ vs ██████████ had missing data ██████████ as described in Table 11.

The CS also reports the proportion achieving certain thresholds for improvement (■, ■ or ■ points) and deterioration (■ points). For KCCQ-TSS, ■ differences ■ in terms of the proportion with ■, and ■ and ■ were identified. The point estimate for ■ also suggested ■ dapagliflozin, but ■ (Figure 12 of the CS). Although these thresholds are different to those prespecified and reported in the CSR, the EAG notes that these thresholds are in line with those reported ■ and the EAG's clinical experts considered them to be reasonable thresholds for determining whether improvements or deteriorations are clinically significant.³⁶

3.3.2.2 EQ-5D

EQ-5D data were also reported in the DELIVER trial in the form of the EQ-5D-5L questionnaire. The company note that ■ in quality of life compared to baseline were observed for ■ but that there

■. The CSR indicates that for the EQ-5D-5L visual analogue scale, mean [standard deviation] baseline values were ■ between arms (■, n=■ vs n=■ in dapagliflozin and placebo arms, respectively) and values at 8 months were ■, n=■ vs n=■. The company explains in the CS that this is as expected given it is

As described in Section B.3.4.1 of the CS, patient-level data, once mapped to EQ-5D-3L, were used in the economic model to inform health state utility values and utility decrements (see Sections 4.2.7.1 and 4.2.7.2 for further detail).

3.3.3 Treatment discontinuation

As indicated in Figures 6 and 17 of the CS, over the median trial follow-up of ■, premature permanent discontinuation of treatment occurred in ■ and ■ patients in dapagliflozin and placebo groups, respectively (■% in the dapagliflozin group and ■% in the placebo group), where the denominator is those that had at least one dose of study drug post-

randomisation. Reasons for discontinuation were [REDACTED] between the two arms, which were described as subject decision, AE or other reasons.

As described in Section B.3.3.4 of the CS, the per-cycle probability of dapagliflozin treatment discontinuation applied in the economic model was informed by data observed in the DELIVER trial (see Sections 4.2.3 and 4.2.4 for further detail).

3.3.4 Adverse events

A breakdown of on-treatment AEs observed in the DELIVER trial is provided in Tables 22 and 23 of the CS. Analyses were performed in the safety analysis set, which included those randomised that received at least one dose of treatment and received the treatment they were randomised to (n=3126 vs n=3127 in dapagliflozin vs placebo groups, respectively). Mean duration of exposure was [REDACTED] treatment arms ([REDACTED], range [REDACTED]).

The EAG provides a summary of AEs from the DELIVER trial in Table 13 below. This table focuses on events that were classed as serious AEs (SAEs), were related to the study drug and/or led to a downstream event (e.g., death or discontinuation of study drug), those that were included in the economic model (Table 43 of the CS) or were mentioned in the Summary of Product Characteristics for dapagliflozin (Table 25 of the CS).¹⁰ Events where a higher rate was observed in the dapagliflozin arm are also included in this table. Further details of AE inclusion in the economic model are provided in Section 4.2.6.3.

The EAG concludes that, overall, on-treatment AEs are generally balanced between treatment groups, including SAEs and those leading to death, with events slightly [REDACTED] in the dapagliflozin arm in most cases. The following exceptions are noted, where rates are higher in the dapagliflozin group: [REDACTED], any SAE or DAE suggestive of volume depletion, any definite or probable diabetic ketoacidosis, [REDACTED], any ischaemic stroke SAE, [REDACTED], any atrial fibrillation SAE, any cellulitis SAE and any peripheral arterial occlusive disease SAE. However, most differences for events that were higher for dapagliflozin were [REDACTED] with rates based on a [REDACTED] of events; the biggest difference was for [REDACTED], where the rate was [REDACTED]% in the dapagliflozin arm and [REDACTED]% in the placebo arm.

Table 13. Summary of adverse events in the safety population – DELIVER trial (adapted from Tables 22 and 23 of the CS), on-treatment events

Adverse event	Dapagliflozin + SoC (n=3126), median follow-up [REDACTED]	Placebo + SoC (n=3127), median follow-up [REDACTED]
	n (%)	n (%)
SAEs, AEs related to the study drug or AEs leading to downstream events		
Any AE leading to death	[REDACTED]	[REDACTED]
Any SAE (including those leading to death)	1361 (43.5)	1423 (45.5)
Any AE leading to discontinuation of IP	182 (5.8)	181 (5.8)
Any AE leading to interruption of IP	436 (13.9)	494 (15.8)
Any AE possibly related to IP ^a	[REDACTED]	[REDACTED]
AKI		
Any SAE of AKI (<i>included in economic model</i>)	46 (1.5)	50 (1.6)
Fracture		
Any SAE of fracture (<i>included in economic model</i>)	[REDACTED]	[REDACTED]
UTI		
Any SAE of UTI (<i>included in economic model</i>)	[REDACTED]	[REDACTED]
Volume depletion		
Any SAE or DAE suggestive of volume depletion ^b	42 (1.3)	32 (1.0)
Any DAE suggestive of volume depletion ^b	[REDACTED]	[REDACTED]
Any SAE suggestive of volume depletion ^b (<i>included in economic model</i>)	[REDACTED]	[REDACTED]
Amputation		
Any amputation ^c (<i>included in economic model</i>)	19 (0.6)	25 (0.8)
Other (included in SmPC or where rate is higher in dapagliflozin arm)		

Any renal SAE ^b	██████	██████
Any major hypoglycaemic event ^d	6 (0.2)	7 (0.2)
Any definite or probable diabetic ketoacidosis ^e	2 (0.1)	0 (0.0)
Fournier' gangrene	0 (0.0)	0 (0.0)
Any SAE of genital infection ^b	██████	██████
Any SAE of tubulointerstitial nephritis	██████	█
Any stroke AE ^f	██████	██████
Ischaemic stroke SAE	66 (2.1)	60 (1.9)
Atrial fibrillation SAE	57 (1.8)	47 (1.5)
Cellulitis SAE	31 (1.0)	18 (0.6)
Peripheral arterial occlusive disease SAE	22 (0.7)	14 (0.4)

Abbreviations: AE, adverse event; AKI, acute kidney injury; CRF, case report form; CS, company submission; DAE, AE leading to discontinuation of IP; IP, investigational product; SAE, serious adverse event; SmPC, summary of product characteristics; SoC, standard of care; UTI, urinary tract infection.

^aPossibly related to IP, as assessed by the investigator; ^bbased on a predefined list of preferred terms; ^creported by the investigator on the CRF amputation form, including surgical or spontaneous/non-surgical amputation, excluding amputation due to trauma; ^dAE with the following criteria confirmed by the investigator: i) symptoms of severe impairment in consciousness or behaviour, ii) need of external assistance, iii) intervention to treat hypoglycaemia, iv) prompt recovery of acute symptoms following the intervention reported by the investigator in CRF; ^eevents adjudicated as definite or probable diabetic ketoacidosis; ^fInvestigator-reported diagnosis from the cerebrovascular events CRF (haemorrhagic, ischaemic, undetermined).

This table includes SAEs with an onset date on or after date of first dose of IP (on and off treatment), and up to and including 30 days following last dose of IP (on treatment).

3.3.5 Subgroups

Subgroup data discussed below originates either from the CS (Section B.2.7), the CSR or the company's response to clarification questions A1, A2 and A4. The EAG focuses on outcomes where [REDACTED] were observed rather than discussing all subgroup results that were provided in detail. This section focuses on subgroup strategies that provided further rationale for decisions made by the EAG about the economic model and/or were queried at clarification based on possible treatment differences in clinical practice and a clinical rationale for potential differences in efficacy. Other subgroup strategies that did not provide further rationale for decisions made by the EAG about the economic model are presented in Appendix 8.1.

3.3.5.1 Previous LVEF \leq 40% vs consistent LVEF >40%

Patients were not stratified for this factor at randomisation and this was a *post-hoc* subgrouping strategy not mentioned in the CSR. Although those with a prior LVEF \leq 40% that has since improved to be >40% (HFimpEF) may be treated as HFrEF, they now have an LVEF >40% and may be an important group if not already receiving dapagliflozin when their LVEF was \leq 40%. The EAG note that to be included in the DELIVER trial, participants could not have been treated with an SGLT2 inhibitor within 4 weeks prior to randomisation or have previous intolerance to an SGLT2 inhibitor.

The results in Table 14 show that for certain outcomes, this group may have a [REDACTED] compared to those with a consistent LVEF >40% (particularly for CV mortality), although the EAG acknowledge the limitations of subgroup analyses highlighted by the company in response to clarification question A1. Hazard ratios (HRs) for other outcomes (HHF, UHFV, all-cause hospitalisation and HF event composite), and the rate of AEs, were [REDACTED] (see company response to clarification questions A1 and A2). KCCQ-TSS results [REDACTED] between subgroups, with results slightly [REDACTED] although the EAG notes that baseline values [REDACTED] in this subgroup (Tables 34 and 37 in the appendix of the company's response to clarification).

The EAG considers that using the overall FAS population with both groups included is reasonable given this effect [REDACTED] and that the results for the overall FAS population are [REDACTED], although there is a [REDACTED] for CV mortality, with a [REDACTED] between

treatment arms identified for the [REDACTED] subgroup but not for the [REDACTED] subgroup. The EAG considers that the subgroup results for CV mortality [REDACTED] provide further rationale for removing CV mortality benefit for dapagliflozin in the base case of the economic model (see Section 4.2.6.4 for further details).

Table 14. Outcomes of interest for prior LVEF ≤40% vs consistent LVEF >40% subgroups

Outcome	Dapagliflozin + SoC Number with events (event rate)	Placebo + SoC Number with events (event rate)	HR (95% CI; p-value)	Interaction p-value (vs consistent LVEF >40% group)
Prior LVEF ≤40% (n=[REDACTED])				
Composite of CV mortality and HF events	[REDACTED]	[REDACTED]	0.74 (0.56 to 0.97; p=0.031)	[REDACTED]
CV mortality	[REDACTED]	[REDACTED]	[REDACTED]	[REDACTED]
All-cause mortality	[REDACTED]	[REDACTED]	[REDACTED]	[REDACTED]
Consistent LVEF >40% (n=[REDACTED])				
Composite of CV mortality and HF events	[REDACTED]	[REDACTED]	[REDACTED]	N/A
CV mortality	[REDACTED]	[REDACTED]	[REDACTED]	N/A
All-cause mortality	[REDACTED]	[REDACTED]	[REDACTED]	N/A
Overall FAS population (n=3131 vs n=3132)				
Composite of CV mortality and HF events	[REDACTED]	[REDACTED]	0.82 (0.73 to 0.92; p=[REDACTED])	N/A
CV mortality	231 [REDACTED]	261 [REDACTED]	0.88 (0.74 to 1.05; p=[REDACTED])	N/A
All-cause mortality	497 (NR)	526 (NR)	0.94 (0.83 to 1.07; p=[REDACTED])	N/A

Abbreviations: CIs, confidence intervals; CV, cardiovascular; FAS, full analysis set; HF, heart failure; HHF, hospitalisation for heart failure; HR, hazard ratio; LVEF, left ventricular ejection fraction; N/A, not applicable; NR, not reported; SoC, standard of care; T2DM, type 2 diabetes mellitus; UHFV, urgent heart failure visit.

[REDACTED]

3.3.5.2 LVEF categories ($\leq 49\%$, 50-59% and $\geq 60\%$)

Patients were not stratified by baseline LVEF category but it was a prespecified subgroup analysis. The EAG notes that all of these subgroups are of relevance to the population covered in this appraisal, but feedback from the EAG's clinical experts suggested that in practice those with LVEF $\leq 49\%$ may have some treatment options usually used for HFrEF patients.

The results provided for these subgroups indicate no consistent pattern in terms of differences between groups for clinical outcomes such as mortality and HF events; while for some outcomes there was a [REDACTED] of dapagliflozin in the [REDACTED] and [REDACTED] groups, for others dapagliflozin was [REDACTED] in the [REDACTED] and/or [REDACTED] groups compared to the 50-59% group. AEs were [REDACTED] across subgroups. Of note, for KCCQ-TSS results, there appeared to be a consistently [REDACTED] effect of dapagliflozin vs placebo in the [REDACTED] group in terms of change from baseline scores (compared to the [REDACTED]% group) and responder analyses (compared to [REDACTED]) despite similar baseline values. Regardless, the EAG consider use of the overall FAS population to be appropriate as all three of these groups are of relevance to the population this appraisal focuses on.

3.3.5.3 Presence vs absence of type 2 diabetes mellitus (T2DM)

While the EAG considers that T2DM is a common comorbidity in those with HFpEF or HFmrEF, meaning the T2DM group is a relevant subpopulation for this appraisal, the EAG notes that patients with a T2DM diagnosis already have access to dapagliflozin and may already be receiving an SGLT2 inhibitor based on NICE appraisals TA288, TA390 and TA418.¹⁶⁻¹⁸

The results provided for the T2DM and no T2DM subgroups indicate [REDACTED] results across most outcomes. Outcomes where [REDACTED] the two subgroups based on [REDACTED] was observed include [REDACTED], [REDACTED] and [REDACTED], where [REDACTED] for dapagliflozin was observed in the T2DM subgroup compared to the group without T2DM, and [REDACTED], which occurred [REDACTED] in the T2DM subgroup (Table 15 and Table 16 below):

- while the [REDACTED] of dapagliflozin in terms of [REDACTED] in the T2DM group, the EAG notes that in both subgroups, and the overall FAS population, the results are [REDACTED] with [REDACTED] between treatment arms;

- there is [REDACTED] for dapagliflozin compared to placebo in terms of [REDACTED] in the T2DM subgroup, which was [REDACTED] for the group without T2DM or the overall FAS population;
- KCCQ-TSS results suggest there is [REDACTED] of dapagliflozin compared to placebo in the T2DM subgroup [REDACTED] the group without T2DM when considering responder analyses. Change from baseline results indicate [REDACTED] of dapagliflozin in both groups, which [REDACTED] the T2DM group. For outcomes other than the 15-point improvement from baseline, the overall FAS population results [REDACTED], with [REDACTED] of dapagliflozin compared to placebo reported.
- although the proportion with amputation events [REDACTED] in the T2DM group, the EAG highlights that [REDACTED] amputation events in DELIVER occurred in this group; a [REDACTED] was [REDACTED] observed within the T2DM group.

In terms of [REDACTED], the EAG notes that it is possible those with T2DM [REDACTED] from dapagliflozin compared to those without T2DM but consider the overall FAS population to be appropriate given it is a commonly seen comorbidity in the HFpEF and HFmrEF populations.

Given that amputation is not thought to be a typical AE associated with HF, the fact that the company's concern about a link between SGLT2 inhibitors and amputation events was not shared by the EAG's clinical experts, and that amputation is a key driver in the economic model, the EAG do not consider it appropriate to include amputation events in the EAG base case, particularly as [REDACTED] within the group that may already be eligible for dapagliflozin based on their T2DM diagnosis (see Section 4.2.6.3. for further details). The EAG further notes that based on the response to clarification question A17, there was no formal assessment or monitoring of how well-controlled T2DM was during the DELIVER trial and that it is possible that poor control of T2DM may have contributed to any amputation events that occurred.

Table 15. Outcomes of interest for T2DM vs no T2DM subgroups – dichotomous outcomes

Outcome	Dapagliflozin + SoC Number with events/number analysed (event rate)	Placebo + SoC Number with events/number analysed (event rate)	HR or OR (95% CI; p-value)	Interaction p-value (vs no T2DM group)
T2DM group				
CV mortality	████████	████████	████████████████	████
All-cause hospitalisation	████████	████████	████████████████	████
KCCQ-TSS				
≥5-point improvement	████████	████████	████████████████	████
≥10-point improvement	████████	████████	████████████████	████
≥15-point improvement	████████	████████	████████████████	████
≥5-point deterioration	████████	████████	████████████████	████
Amputation events	████████	████████	NR	NR
No T2DM group				
CV mortality	████████	████████	████████████████	N/A
All-cause hospitalisation	████████	████████	████████████████	N/A
KCCQ-TSS				
≥5-point improvement	████████	████████	████████████████	N/A
≥10-point improvement	████████	████████	████████████████	N/A
≥15-point improvement	████████	████████	████████████████	N/A
≥5-point deterioration	████████	████████	████████████████	N/A
Amputation events	████████	████████	NR	N/A
Overall FAS population				

CV mortality	231/3131	261/3132	HR 0.88 (0.74 to 1.05; p=	N/A
All-cause hospitalisation				N/A
KCCQ-TSS				
≥5-point improvement				N/A
≥10-point improvement				N/A
≥15-point improvement				N/A
≥5-point deterioration				N/A
Amputation events			NR	N/A
Abbreviations: CI, confidence interval; CV, cardiovascular; FAS, full analysis set; HR, hazard ratio; KCCQ-TSS, Kansas City Cardiomyopathy Questionnaire – Total Symptom Score; HF, heart failure; HHF, hospitalisation for heart failure; N/A, not applicable; NR, not reported; OR, odds ratio; SoC, standard of care; T2DM, type 2 diabetes mellitus; UHFV, urgent heart failure visit.				

Table 16. Outcomes of interest for T2DM vs no T2DM subgroups – KCCQ-TSS change from baseline scores

	Baseline Mean (SD), n ^a	Change from baseline Mean (SD), n ^a	Dapagliflozin vs placebo Mean difference (95% CI; p- value)	Interaction p-value (vs no T2DM group)
T2DM group				
Dapagliflozin + SoC				
Placebo + SoC				
No T2DM group				
Dapagliflozin + SoC				N/A
Placebo + SoC				
Overall FAS population				

3.3.5.4 Geographical location

For results reported in the CSR, there is, numerically, [REDACTED] in the

[REDACTED] for CV death as an individual outcome. The HR for CV death in the overall FAS population is [REDACTED] than that reported specifically for the EU + Saudi Arabia subgroup (HR 0.88 [95% CI: 0.74 to 1.05; p=0.1678] vs [REDACTED]). Although both of these results indicate [REDACTED] for dapagliflozin compared to placebo for CV death, the EAG considers that, overall, focusing on the FAS population is reasonable. The EAG considers that the result in the [REDACTED] may provide further rationale for removing CV mortality benefit for dapagliflozin in the EAG base case (see Section 4.2.6.4 for further details), as the HR in this group is [REDACTED] and this is a subgroup that should be most applicable to UK patients given patients from [REDACTED] are included.

3.4 Conclusions of the clinical effectiveness section

Evidence submitted by the company in support of the clinical efficacy and safety of dapagliflozin for patients with HFpEF or HFmrEF is focused on a single double-blind RCT (DELIVER). The EAG considers this RCT to be of generally good quality, with limited concerns in terms of risk of bias, and agrees with the decision not to focus on the PRESERVED-HF trial (Section 3.2). The DELIVER trial also aligns well with the NICE final scope in terms of population, intervention, comparators and outcomes (Section 2.3).

The EAG's clinical experts consider the DELIVER trial to be a reasonable representation of the population relevant to the appraisal in UK clinical practice, although some differences, such as higher use of treatments other than diuretics and slightly lower mean age in the trial compared to UK practice, were highlighted (Section 2.3.1).

Results for the overall FAS population indicate a statistically significant benefit for dapagliflozin vs placebo in terms of the composite primary outcome in the trial (HF events [HHF or UHFV] or CV mortality) [REDACTED], but not for

[REDACTED] (Section 3.3.1). Results for quality of life measured using the KCCQ-

TSS score indicate [REDACTED] dapagliflozin in terms of change from baseline scores and proportions with a certain level of improvement or deterioration from baseline (Section 3.3.2.1). The EAG notes that while a change from baseline score of [REDACTED], was observed for dapagliflozin and placebo arms, it is unclear whether the difference between arms observed is clinically meaningful.

AEs were generally well-balanced between the two arms of the trial, including SAEs and those leading to death; for those where rates were slightly higher in the dapagliflozin arm compared to placebo, the biggest difference was [REDACTED] for [REDACTED] (Section 3.3.4).

The EAG highlights the inclusion of HFimpEF group in the DELIVER trial, which is a group that in clinical practice would continue treatments initiated for HFref based on feedback from the EAG's clinical experts, possibly including dapagliflozin if it had been initiated when they were considered to have HFref (the EAG notes that SGLT2 inhibitor use within 4 weeks prior to randomisation or previous intolerance to an SGLT2 inhibitor were exclusion criteria in DELIVER). Subgroup results for outcomes in this group were considered and although [REDACTED] of prior LVEF status, results for dapagliflozin vs placebo for CV mortality were [REDACTED] [REDACTED] (Sections 2.3.4 and 3.3.5.1). This was used to further inform a decision by the EAG about CV mortality benefit in the economic model.

Other subgroups explored further by the EAG include different LVEF categories >40%, presence vs absence of T2DM, geographical location, and SBP and BMI categories (Sections 3.3.5.2 to 3.3.5.4, and Appendix 8.1). Of these, T2DM and geographical location results contributed to the rationale for certain decisions made by the EAG in terms of the economic model.

4 Cost effectiveness

Table 17 below presents the incremental cost-effectiveness results of the company's updated (post-clarification) base case results.

Table 17. Company's base case results (adapted from Table 59 of the CS)

Interventions	Total Costs (£)	Total LYG	Total QALYs	Incremental costs (£)	Incremental LYG	Incremental QALYs	ICER (£/QALY)
Deterministic results							
Dapagliflozin	£14,352	8.295	5.052	£1,885	0.370	0.251	7,519
Placebo	£12,467	7.926	4.801	-	-	-	
Probabilistic results							
Dapagliflozin	£14,315	-	4.974	£1,896	-	0.261	£7,276
Placebo	£12,419	-	4.714	-	-	-	-

Abbreviations: CS, company submission; ICER, incremental cost effectiveness ratio, LYG, life year gained; QALY, quality adjusted life year.

4.1 EAG comment on the company's review of cost effectiveness evidence

The company carried out a systematic literature review (SLR), using a single search strategy, to identify existing:

- economic evaluations of interventions for chronic heart failure (HF) and a left ventricular ejection fraction (LVEF) >40%;
- health-state utility values (HSUVs) for patients with chronic HF and a LVEF >40%; and,
- cost and resource use studies in chronic HF and a LVEF >40% conducted in the UK.

Searches were conducted in June 2022 and updated in July 2022. A summary of the External Assessment Group (EAG)'s critique of the methods implemented by the company to identify relevant evidence is presented in Table 18. Due to time constraints, the EAG was unable to replicate the company's searches and appraisal of identified abstracts.

Table 18. Critique of the methods implemented by the company to identify relevant health economic evidence

Systematic review step	Section of CS in which methods are reported			EAG assessment of robustness of methods
	CE evidence	HRQoL evidence	Cost and resource use evidence	
Search strategy	Appendix G	Appendix H	Appendix I	<p>Appropriate.</p> <p>The following electronic databases were searched: MEDLINE, MEDLINE In-Process, MEDLINE Epub Ahead of Print and Embase via the Ovid SP platform, and the International HTA Database through the INAHTA platform. Conference proceedings from major cardiology conferences from the last two years were manually hand-searched in July 2022 as part of the SLR update. The exclusion of abstracts from conferences prior to 2020 was justified under the assumption that high-quality research would since have been published in a peer-reviewed journal. HTA websites were searched in July 2022 for studies presented in relevant HTAs, and three economic databases were queried for HSUVs and CE analyses.</p>
Inclusion / exclusion criteria	Appendix G, Table 22	Appendix H, Table 27	Appendix I, Table 31	<p>Appropriate.</p> <p>The SLR for cost-effectiveness evidence was conducted to be broad, and the intervention and comparator terms considered a range of possible treatments for chronic HF and an LVEF >40%, including SGLT2 inhibitors (e.g., canagliflozin, empagliflozin, dapagliflozin, ertugliflozin) as well as loop diuretics, ACE inhibitors, ARBs and beta blockers.</p>
Screening	Appendix G (for PRISMA, see Figure 2)	Appendix H (for PRISMA, see Figure 3)	Appendix I (for PRISMA, see Figure 4)	<p>Appropriate.</p> <p>Two reviewers assessed each title and abstract review, and each full-text review. Full-text disagreements were resolved by a third reviewer. Excluded studies lists were provided with reasons for exclusion.</p>
Data extraction	Appendix G, Table 25	Appendix H, Table 30	Appendix I, Table 34	<p>Appropriate.</p> <p>Of the economic evaluations reviewed none were deemed appropriate for the study leading to no data extractions.</p>
Quality assessment of	Appendix G, Table 26	N/A	N/A	<p>Appropriate.</p>

included studies				The quality of all included economic evaluations was assessed using the Drummond checklist, which was completed by one individual and verified by another.
<p>Abbreviations: ACE, angiotensin-converting enzyme; ARBs, angiotensin receptor blockers; CE, cost-effectiveness; CS, company submission; EAG, External Assessment Group; HF, heart failure; HRQoL, health related quality of life; HRQOL, health-related quality of life; HSUV, health state utility value; HTA, health technology appraisal; INAHTA, International Network of Agencies for Health Technology Assessment; LVEF, left ventricular ejection fraction; N/A, not applicable; PRISMA, Preferred Reporting Items for Systematic Reviews and Meta-analyses; SGLT2, Sodium-glucose Cotransporter-2; SLR, systematic literature review.</p>				

The SLR identified a total of 756 records via the electronic database searches and 1,742 records via the supplementary searches. Subsequently, 89 full-text records were screened against the eligibility criteria, with 16 records included in the SLR as being relevant to one or more of the three types of evidence the SLR aimed to identify. This included: 1 cost-effectiveness paper, 9 health-related quality of life (HRQoL) papers (6 unique studies) and 6 cost papers (2 unique studies). Only primary publications were used for data extraction.

The cost-effectiveness paper was a cost per outcome study (Tsuban *et al.* 2021), which evaluated the annual number needed to treat to prevent the composite outcome of HF hospitalisation and cardiovascular (CV) mortality for either spironolactone or sacubitril/valsartan.⁵⁰ This study was not considered to provide relevant evidence for the decision problem of this single technology appraisal (STA), or any relevant assumptions that could be leveraged for the economic analysis in this submission and was therefore not considered further. As a result, the model structure used in this appraisal was closely aligned with the model used in the previous appraisal for dapagliflozin as a treatment for HF with a reduced ejection fraction (HFREF) (TA679).¹ For further details on the company's model structure and modelling assumptions, see Section 4.2.4.

All the included HRQoL studies (ASCEND-HF, IMPRESS-AF, REACH-HF, REAL-HF, SOCRATES-PRESERVED and Jonsson 2020) reported EQ-5D data for patients with HF and an LVEF >40%. However, none reported health state utility values (HSUVs) that aligned with the health states of the cost-effectiveness model constructed for this submission.⁵¹⁻⁵⁵ Moreover, no adverse event (AE) disutilities were reported within the included studies. For these reasons, the company did not consider the included studies further; utility data directly from the clinical trial (DELIVER) were preferred. Please refer to Section 4.2.7 for further details on the HRQoL data applied in the model.

Neither of the cost papers (IMPRESS-AF and REACH-HF) provided relevant costs or resource use data associated with dapagliflozin or the relevant comparator (standard of care; SoC).^{51, 52} As such, the company identified alternative cost and resource use estimates using previous National Institute and Health and Care Excellence appraisals (NICE) in HF, including TA679. Please refer to Section 4.2.8 for further details on the cost and resource use data applied in the model.

Overall, the EAG is satisfied that no relevant evidence in patients with chronic HF and a LVEF >40% has been omitted from the company’s SLR. However, the EAG is unclear if the preferred assumptions from the recent appraisal of empagliflozin as a treatment for HFrEF (TA773), which was published after TA679, have been considered; the company only stated a preference for following the precedent set by TA679 in the company submission (CS).⁵⁶ For completeness, the EAG will consider the assumptions accepted in TA773 and TA679, where appropriate.

4.2 Summary and critique of company’s submitted economic evaluation by the EAG

4.2.1 NICE reference case checklist

Table 19 summarises the EAG’s appraisal of the company’s economic evaluation against the requirements set out in the NICE reference case checklist for the base-case analysis, with reference to the NICE final scope outlined in Section 2.3.

Table 19. NICE reference case checklist

Element of health technology assessment	Reference case	EAG comment on company’s submission
Perspective on outcomes	All direct health effects, whether for patients or, when relevant, carers	All relevant health effects for adult patients with HFpEF or HFmrEF have been included.
Perspective on costs	NHS and PSS	All relevant costs have been included and are based on the NHS and PSS perspective.
Type of economic evaluation	Cost utility analysis with fully incremental analysis	Cost-utility analysis has been provided by the company. Fully incremental analysis not required as there is only one relevant comparator in the analysis.
Time horizon	Long enough to reflect all important differences in costs or outcomes between the technologies being compared	Lifetime horizon (101 years of age)
Synthesis of evidence on health effects	Based on systematic review	The company performed an appropriate systematic review

Measuring and valuing health effects	Health effects should be expressed in QALYs. The EQ-5D is the preferred measure of health-related quality of life in adults.	QALYs based on EQ-5D from company sponsored DELIVER-ITT study. ³⁹ A scenario was explored using EQ-5D data from the company sponsored DAPA-HF trial for HFrEF. ⁵⁷
Source of data for measurement of health-related quality of life	Reported directly by patients and/or carers	EQ-5D data obtained from the company sponsored DELIVER-ITT study which included patients with >40% LVEF. ³⁹ A scenario was explored using EQ-5D data obtained from the company sponsored DAPA-HF trial which included patient with ≤40%LVEF. ⁵⁷
Source of preference data for valuation of changes in health-related quality of life	Representative sample of the UK population	The EQ-5D data from the company sponsored DELIVER-ITT study. Despite some differences highlighted (see Section 2.3.1) the EAG's clinical experts consider it to be a reasonable representation of the UK population.
Equity considerations	An additional QALY has the same weight regardless of the other characteristics of the individuals receiving the health benefit	The economic evaluation matches the reference case.
Evidence on resource use and costs	Costs should relate to NHS and PSS resources and should be valued using the prices relevant to the NHS and PSS	Costs included in the analysis have been sourced using NHS reference costs, PSSRU and the drugs and pharmaceutical eMIT.
Discounting	The same annual rate for both costs and health effects (currently 3.5%)	A discount rate of 3.5% has been used for both costs and health effects.
Abbreviations: EAG, External Assessment Group; eMIT, electronic marketing tool; HFmrEF, heart failure with mildly reduced LVEF; HFpEF, heart failure with preserved LVEF; HFrEF, heart failure with reduced ejection fraction; ITT, intention to treat; LVEF, left ventricular ejection fraction; NHS, National Health Service; NICE, National Institute for Health and Care Excellence; PSS, Personal Social Services; PSSRU, Personal Social Services Research Unit; QALY, quality adjusted life year		

4.2.2 Population

The patient population considered in the cost-effectiveness analysis was adults with symptomatic chronic HF with preserved (HFpEF) or mildly reduced (HFmrEF) LVEF in accordance with the [REDACTED] and the decision problem considered in the CS. This is aligned to the population investigated in the DELIVER trial that compares dapagliflozin against placebo, as discussed in Section 2.3.1.

A scenario analysis was conducted by the company that used patient characteristics from the UK Clinical Practice Research Datalink (CPRD) study, reflecting a [REDACTED] mean age ([REDACTED] vs 71.7 years), comparable mean body mass index (BMI) and gender balance compared to the DELIVER study. The use of UK CPRD baseline population statistics in the model led to an increase in the company's base case incremental cost effectiveness ratio (ICER) of £327 to £7,847.

EAG critique

In line with consulted clinical experts, the EAG agrees that a scenario utilising a population with an [REDACTED] mean age was warranted as this is thought to be more reflective of the UK HFpEF and HFmrEF populations. The company has shown that changing age had minimal impact on the ICER and so the EAG agrees with the use of the DELIVER trial population in the cost-effectiveness model as their base case.

4.2.3 Interventions and comparators

The base case analysis of the cost effectiveness model compared dapagliflozin (10mg/daily) + SoC (henceforth called dapagliflozin) to placebo + SoC (henceforth called SoC). SoC comprised of a weighted average of 80% furosemide (40mg/daily) and 20% bumetanide (1mg/daily), informed by UK clinical expert feedback to the company. The cost of additional therapies to treat comorbidities were not included in the model as the use of these therapies was expected to be the same in both trial arms.

A constant probability of dapagliflozin treatment discontinuation informed by the DELIVER trial was included in the model ([REDACTED]), with those discontinuing treatment becoming subject to the same risks, costs, and utility decrements as patients in the SoC arm.

EAG critique

On consultation with their independent clinical experts, the EAG agrees with the weighted average and use of furosemide and bumetanide as the SoC in the model. The application of the dapagliflozin discontinuation rate and exclusion of comorbidity treatments are equally appropriate. Additionally, as the difference in CV and non-CV mortality events were similar between the study arms the EAG agrees in the suitability of omitting the cost of comorbidity treatments. The same also applies for other treatments that may be used in UK clinical practice (based on feedback from the EAG's clinical experts) for certain groups included in the trial (HFmrEF and those with a previous LVEF \leq 40%, see Section 2.3.2).

4.2.4 Modelling approach and model structure

The company used a Markov state-transition model (Figure 1) which allowed disease progression to be modelled through the transition between four discrete health states, corresponding to Kansas City Cardiomyopathy Questionnaire Total Symptom Score (KCCQ-TSS) quartiles, with higher scores representing lower symptom frequency and severity. Additionally, the model captured the incidence of HF events as transient events, with patient mortality modelled through the application of parametric survival equations describing CV and all-cause mortality. The KCCQ-TSS quartiles were defined as follows:

- Q1: 0-<55;
- Q2: 55-<73;
- Q3: 73-<88;
- Q4: 88-100.

Figure 1. Schematic of Markov state-transition model structure, health states, and possible transitions (reproduced from Figure 18 of the CS)

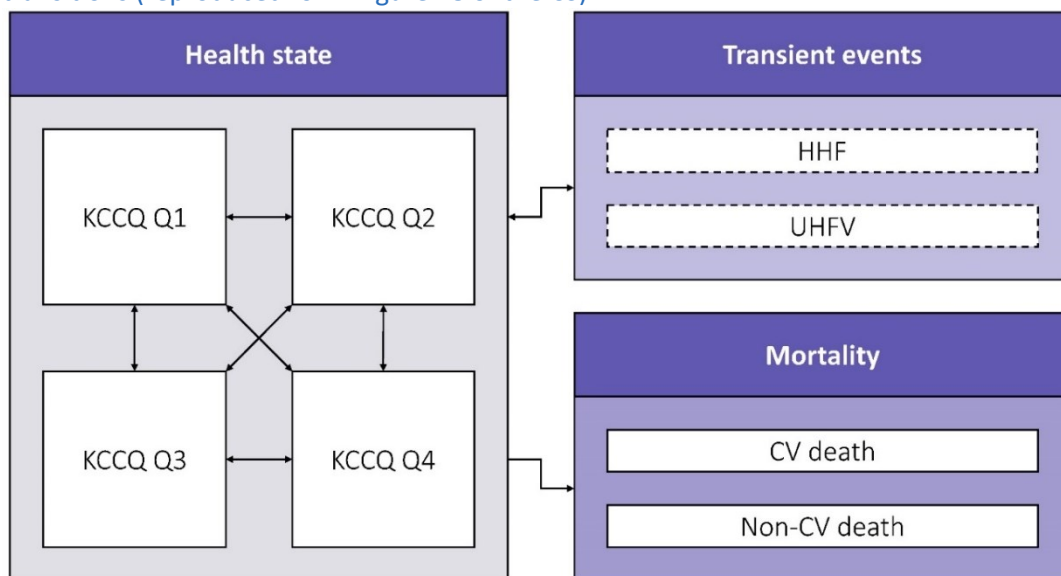

Abbreviations: CS, company submission; CV, cardiovascular; HHF, hospitalisation for heart failure; KCCQ, Kansas City Cardiomyopathy Questionnaire; UHFV, urgent heart failure visit.

At each cycle in the model, a per cycle probability of discontinuing treatment with dapagliflozin due to intolerability or other reasons was applied. Patients discontinuing treatment with dapagliflozin were modelled the same as those receiving SoC. Additionally, the distribution of the modelled

cohort across each KCCQ-TSS quartile was informed using the distribution seen in the DELIVER trial at baseline.

The company justified the use of the model, explaining how the KCCQ-TSS was a validated and established self-administered instrument for quantifying HF-related symptoms, function, and HRQoL in patients with HF. The inclusion of KCCQ-TSS quartiles as health states to model disease progression is in line with the previous dapagliflozin and empagliflozin submissions TA679 and TA773, the latter of which used the KCCQ-CSSs (Clinical Summary Score).

EAG critique

The EAG agrees with the company that the modelling approach and structure is in line with TA679 and that the same modelling approach and structure is appropriate for this appraisal given the minor difference in study populations and negligible difference in measures of treatment effectiveness.

4.2.5 Perspective, time horizon and discounting

The analysis undertaken by the company took a National Health Service (NHS) and Personal Social Service perspective (PSS), with a discount rate of 3.5% per annum applied to both future costs and benefits.

The time horizon of the model was [REDACTED] years and the company considered this to cover a lifetime time horizon. Based on a starting age of [REDACTED] years, patients would be 101 years old at the end of the time horizon.

EAG critique

The EAG agrees that the perspective, time horizon and discounting are in line with the NICE reference case and appropriate.

4.2.6 Treatment effectiveness

4.2.6.1 Transitions between KCCQ-TSS states

KCCQ-TSS transition probabilities were derived using monthly transition count data from the DELIVER trial. For months where these data were unavailable (as KCCQ-TSS assessments in the DELIVER trial were only scheduled at 1, 4 and 8 months, and final visit), the company used a last observation carried forward (LOCF) approach and therefore assumed that patients remained in their previously recorded quartile until a new observation was made with the same patient in a different

or the same quartile. In response to the factual accuracy check (FAC), the company provided confirmation that the LOCF method was not used for patients missing data at these scheduled assessments and that data were not imputed in this situation. Separate transition probabilities were derived for each treatment arm for the first four months of treatment and subsequent months of treatment. The justification for these specific epochs being that it is in keeping with previous modelling methods for dapagliflozin in HFrEF populations assessed in TA679.¹ For the monthly probability of transitioning between health states defined by KCCQ-TSS quartiles, see Table 34 of the CS.

EAG critique

The EAG was initially unsure as to whether the LOCF method was used only to provide KCCQ-TSS values at months in between scheduled KCCQ-TSS assessments (which took place at 1, 4 and 8 months, and final visit, in the DELIVER trial) or whether it was also for those with missing data at one of the scheduled assessments. At the FAC, the company confirmed that imputation was not performed for those missing data at scheduled assessments, which resolved the EAG's concerns.

Given that KCCQ-TSS measurements were only scheduled to be taken at four time-points (1, 4 and 8 months, and final visit) in the DELIVER trial, while the economic model requires monthly values for each patient to estimate transition probabilities, the EAG considers use of LOCF to be reasonable as long as it is not used after a patient has missed one of the scheduled KCCQ-TSS measurements. This is because KCCQ-TSS scores for those missing assessments may differ to those not missing assessments, which could favour the more effective treatment if treatment effects are maintained after assessments have been missed.

In response to clarification question A7, the company state that ■■■% of patients in each arm of the DELIVER trial had no KCCQ-TSS data available across the 0-4 months or 4 months onwards phases of the trial and that data for these missing patients were not imputed. The EAG is, however, unclear as to how these missing data were treated if they were not imputed (or the LOCF assumption used). It is also unclear whether this proportion refers to any patient with missing data at any of the time-points assessments were scheduled for in the trial (1, 4 and 8 months, and final visit) or whether this proportion is simply those that did not have any measurements at all within a time period (i.e., data missing at 1 and 4 months in the first phase, and missing at 8 months and final visit in the second phase).

The EAG notes that a similar issue was highlighted in TA679, for which the company demonstrated that the ICER was robust to scenario analyses where the probability of transitioning to the next lowest KCCQ-TSS health state was increased by 5% (or, alternatively, the probability of remaining in the same quartile was reduced by 5%), in line with the proportion with missing data at scheduled assessments. This was not performed in the current appraisal but the company have provided confirmation that data missing at scheduled assessments were not imputed.

For further clarification (clarification question B22), the company was asked by the EAG how many monthly slots were used to define the transition probabilities and of those how many were calculated using LOCF from direct observations. The company outlined that of the [REDACTED] monthly slots used to calculate the transition probabilities, [REDACTED] were direct observations from the DELIVER trial.

4.2.6.2 HF events

The incidence of HF events, which includes hospitalisation for heart failure (HHF) and urgent hospitalisation for heart failure (UHFV) were predicted using generalised estimating equations (GEEs) informed using the data collected in the DELIVER study. GEEs were preferred to using constant hazard exponential estimations as they allowed for the clustering of events within the same individual, ensuring the economic analysis captured the full impact of treatment.

In the base case, an adjusted GEE was used to estimate HF event incidence by utilising a variable selection algorithm to produce an estimating equation which minimised the quasi-information criterion (QIC), while allowing for influential patient characteristic covariates as seen in Table 20. The company ran an additional scenario using the unadjusted GEE that solely allowed for treatment effects to estimate HF events over time as in Table 21. The unadjusted GEE decreased the company's base case ICER by £7.

Table 20: Adjusted GEEs predicting UHFV events (reproduced from Table 41 in the CS)

Covariate	Coefficient	SE	p-value
(Intercept)	[REDACTED]	[REDACTED]	[REDACTED]
Dapagliflozin	[REDACTED]	[REDACTED]	[REDACTED]
Sex: male	[REDACTED]	[REDACTED]	[REDACTED]
BMI (kg/m ²)	[REDACTED]	[REDACTED]	[REDACTED]
Race: white	[REDACTED]	[REDACTED]	[REDACTED]
Race: black/African	[REDACTED]	[REDACTED]	[REDACTED]

Race: Other	████	████	████
KCCQ-TSS Q2	████	████	████
KCCQ-TSS Q3	████	████	████
KCCQ-TSS Q4	████	████	████
Log(NT-proBNP) (pg/ml)	████	████	████
T2DM	████	████	████
Baseline AFF	████	████	████

Abbreviations: AFF, atrial fibrillation or flutter; BMI, body mass index; CS, company submission; GEEs, generalised estimating equations; KCCQ, Kansas City Cardiomyopathy Questionnaire; NT-proBNP, N-terminal pro B-type natriuretic peptide; SE, standard error; T2DM, type 2 diabetes mellitus; TSS, Total Symptom Score.

Table 21. Unadjusted GEE coefficients derived from the DELIVER trial (reproduced from Table 42 in the CS)

Parameter	HHF			UHFV		
	Coefficient	SE	p-value	Coefficient	SE	p-value
Intercept	████	████	████	████	████	████
Dapagliflozin	████	████	████	████	████	████

Abbreviations: CS, company submission; GEEs, generalised estimating equations; HHF, hospitalisation for heart failure; SE, standard error; UHFV, urgent heart failure visit.

EAG critique

The EAG notes that, although the DELIVER trial found

████████████████████ between the treatment arms for the proportion with UHFV events (██████████), dapagliflozin has been included in both adjusted and unadjusted GEEs as a UHFV preventing covariate. The dapagliflozin coefficient was also determined ██████████ in these GEEs (████████████████████). As

such, the EAG sought clinical expert opinion on whether the risk of UHFVs would be expected to differ between dapagliflozin and SoC treated patients. The EAG’s clinical experts advised that as UHFVs may be seen as more “planned” than emergency visits; the visit is urgent as it is needed to prevent further deterioration (e.g., IV diuresis), they would not necessarily expect a difference. In order to address this uncertainty in the model, the company was asked to provide a scenario where the rate of UHFVs was the same in both treatment groups. In their response the company did not conduct the scenario as requested, highlighting the limitations associated with p-values and their interpretations. The EAG addressed this concern by running a scenario where dapagliflozin was

removed from the GEE equations used to estimate UHFV events, resulting in an ICER of £7,552 when using the adjusted GEE equation.

4.2.6.3 Adverse events

AEs with a frequency over 1% in the DELIVER trial were included in the economic model. In addition to these criteria, amputation was also included in the model based on a historical linkage between Sodium-glucose Cotransporter-2 (SGLT2) inhibitors and an increased risk of amputation. However, as also mentioned by the company, a recent meta-analysis has suggested there is no established relationship between the two.⁵⁸ Annual probabilities of AEs in each study arm were informed using data from the DELIVER trial.

EAG critique

While the company includes amputation as an AE, clinical expert opinion provided to the EAG suggests they would not expect an increased risk of amputation associated with dapagliflozin. For these reasons the EAG considers that any treatment effect on amputations observed in the study may be confounded by the presence of type 2 diabetes mellitus (T2DM). The EAG asked the company to stratify amputations by T2DM status to help identify any potential confounding, the results of which are presented in Table 22 below (see also, Section 3.3.5.3). The data provided by the company indicates [REDACTED] in the frequency of amputations between treatment arms for patients without T2DM. [REDACTED] were seen in the dapagliflozin group compared to placebo in those with T2DM; however dapagliflozin has been approved by NICE for use in patients with T2DM (TA288, TA390 and TA418) and so it is possible that, in UK clinical practice, these patients would already be receiving treatment (the EAG notes this was not the case in the DELIVER trial, as treatment with an SGLT2 inhibitor within 4 weeks prior to randomisation or previous intolerance to an SGLT2 inhibitor were exclusion criteria).¹⁶⁻¹⁸

Table 22. Stratification of DELIVER amputation events by T2DM status (reproduced from Table 13 in the company's response to clarification question B2)

	Number of patients with amputations in the DELIVER study (N=**)	
	Dapagliflozin + SoC	Placebo + SoC
With T2DM	[REDACTED]	[REDACTED]
Without T2DM	[REDACTED]	[REDACTED]

Abbreviations: SoC, standard of care; T2DM, type 2 diabetes mellitus.

As a scenario, the EAG asked the company to conduct an analysis removing amputation as an AE from the cost effectiveness model. This led to an increase in the ICER of £1,019 (from £7,519 to £8,538). Due to the [REDACTED] in amputations in the non-T2DM patients, and the potential confounding for the current ICER to be driven by a [REDACTED] associated with patients with T2DM (who may already be eligible for treatment), the EAG's preference is to simplify the model by removing the amputations as an AE. This is included as a key issue in Section 1.3 (Issue 1 described in Table 2).

In comparison to the trial data from the SGLT2 inhibitors used in HFrEF populations (TA679 and TA773) the probabilities of AEs appear to lack external validation even when considering the difference in median trial length and populations. Clinical expert opinion provided to the EAG considered that the probability of AEs between HFrEF and HFpEF/HFmrEF populations are expected to be similar; however, as HFpEF and HFmrEF populations are generally older and as such manage additional co-morbidities, the probabilities for some AEs may be higher. Contrary to this opinion and the frequency of similar AEs in the EMPEROR-Preserved (empagliflozin in HFpEF and HFmrEF populations) and DAPA-HF (dapagliflozin in HFrEF populations) trials, this submission outlines [REDACTED] AE probabilities.^{57, 59} This being as much as [REDACTED] in the case of volume depletion as seen in Table 23. In light of these differences, the EAG has asked the company to run a scenario which utilises the AEs probabilities captured in TA679, which appeared more generalisable to HFpEF and HFmrEF populations.¹ The resulting ICER was £8,435, reflecting a £916 increase from the base case.

While providing this scenario, the company noted that any comparisons made between the studies may be unreasonable given the difference in condition and study populations. While the EAG believes that the probabilities associated with the DAPA-HF study may be more generalisable to the HFpEF and HFmrEF for the reasons outlined above, the EAG agrees that given AE probabilities from HFpEF and HFmrEF populations are available they should be used in the base case and are, therefore, not incorporated into the EAGs preferred assumptions. This is included as a key issue in Section 1.3 (Issue 2 described in Table 3).

Table 23. Adverse event probabilities of dapagliflozin trials in HF populations (adapted from table 44 of the CS)

Adverse events	DELIVER-ITT (>40%LVEF)		DAPA-HF (≤40%LVEF)	
	Dapagliflozin plus SoC mean	SoC mean	Dapagliflozin plus SoC mean	SoC mean
AKI	████	████	NR	NR
Renal events	████	████	0.041	0.047
Amputations	████	████	0.003	0.003
Fractures	████	████	0.014	0.014
UTI	████	████	0.016	0.015
Volume depletion	████	████	0.05	0.045

Abbreviations: AKI, acute kidney injury; CS, company submission; HF, heart failure; ITT, intention to treat; NR, not reported; SoC, standard of care; UTI, urinary tract infection.

Additionally, acute kidney injury (AKI) has been included as an AE, while renal events have been omitted from the cost effectiveness model. This contrasts with TA679, in which renal events were included and AKI omitted. The company has outlined in the TA679 submission that AKI was included as one of the many events which constituted renal events; however, a justification was not provided on the preferred use of AKI over renal events or the nuance that one may bring compared to the other. When asked for clarification by the EAG, the company outlined that the use of AKI was preferred as renal events encompasses several difference events such as AKI, dialysis and estimated glomerular filtration rate decline, all of which are associated with different costs and distillates. It was therefore considered inappropriate by the company to include anything other than AKI in the model to inform the impact of dapagliflozin on renal endpoints.

4.2.6.4 CV and all-cause mortality

To adopt a lifetime horizon in the cost effectiveness model, it was necessary to extrapolate the CV and all-cause mortality data captured in the DELIVER trial.

The company deemed the trial data to be too complex to be represented with a single parametric model citing that there was a clear point of separation after one year in both CV and all-cause mortality Kaplan-Meier (KM) curves between the study arms. For this reason, a piecewise model was preferred as to better reflect the trend in hazard over time before and after this point.

In line with NICE DSU TSD 14 guidance, proportional hazard assumptions and accelerated failure time models of the survival data post the inflection point were assessed using visual and statistical

diagnostics.⁶⁰ This assessment informed which parametric models were most suitable to fit the trial data. Akaike information criteria (AIC) and Bayesian information criterion (BIC) scores were calculated for each parametric model and a variable selection algorithm was followed to derive adjusted models with the goal of minimising the AIC.

Of the adjusted models, only the Gompertz model provided clinically plausible predictions for CV mortality, while the others depicted survival probabilities above [REDACTED] [REDACTED] (Figure 2) by which time the surviving patient cohort would be approximately 101.67 years old. With respect to all-cause mortality, only the Weibull and Gompertz provided probability of survival estimates of approximately [REDACTED] as seen in Figure 3.

In efforts to validate the adjusted survival model extrapolations, the DELIVER trial data was re-weighted to the specifics of external study designs to facilitate comparisons. With respect to a SLR and meta-analysis by Jones *et al.* which highlighted 10 studies that reported the 5-year mortality in patients with HF and a LVEF $\geq 50\%$, all bar the Gompertz extrapolation fell within the 95% CI of the meta-analysis 5-year mortality mean.⁶¹ However, these extrapolations still provided clinically implausible CV and all-cause mortality predictions.

Likewise, the DELIVER trial data was re-weighted to reflect that of a study by Shahim *et al.* which investigated long-term mortality outcomes in 397 patients in Sweden and France enrolled in the study post an acute HF event.⁶² The Shahim *et al.* survival estimates were below other explored extrapolated estimates, aligning with the Gompertz distribution after 5 years and the Weibull distribution at 10 years.

Figure 2. Adjusted survival model extrapolations for CV mortality (reproduced from Figure 21 of the CS)

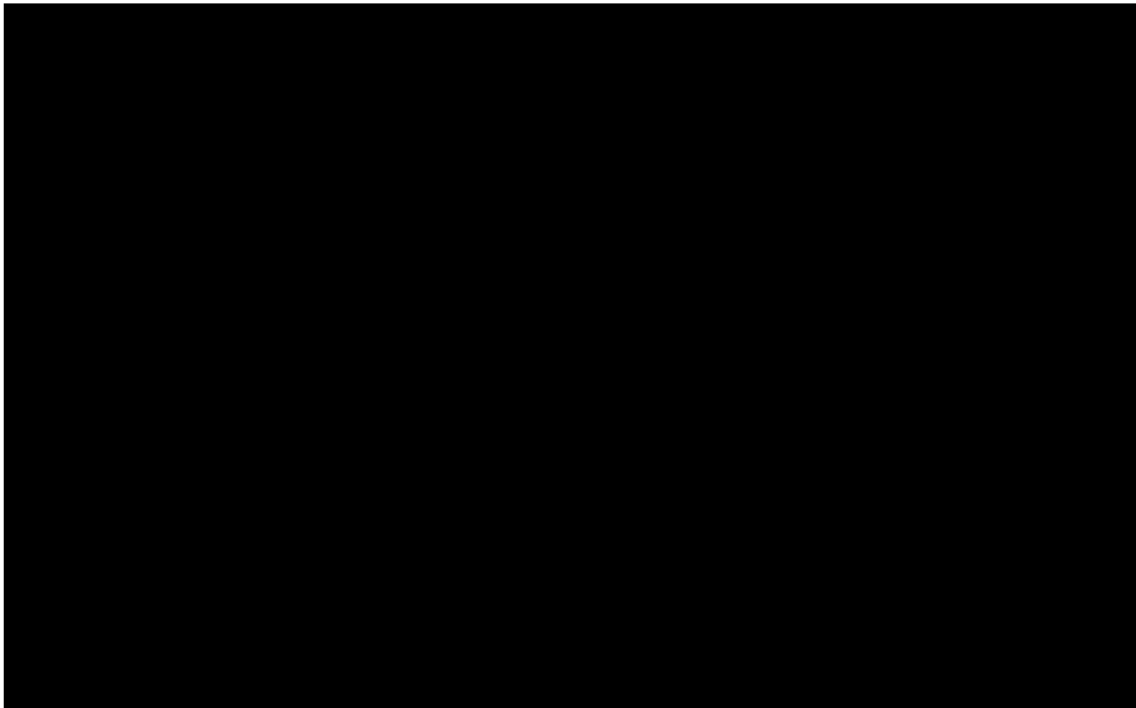
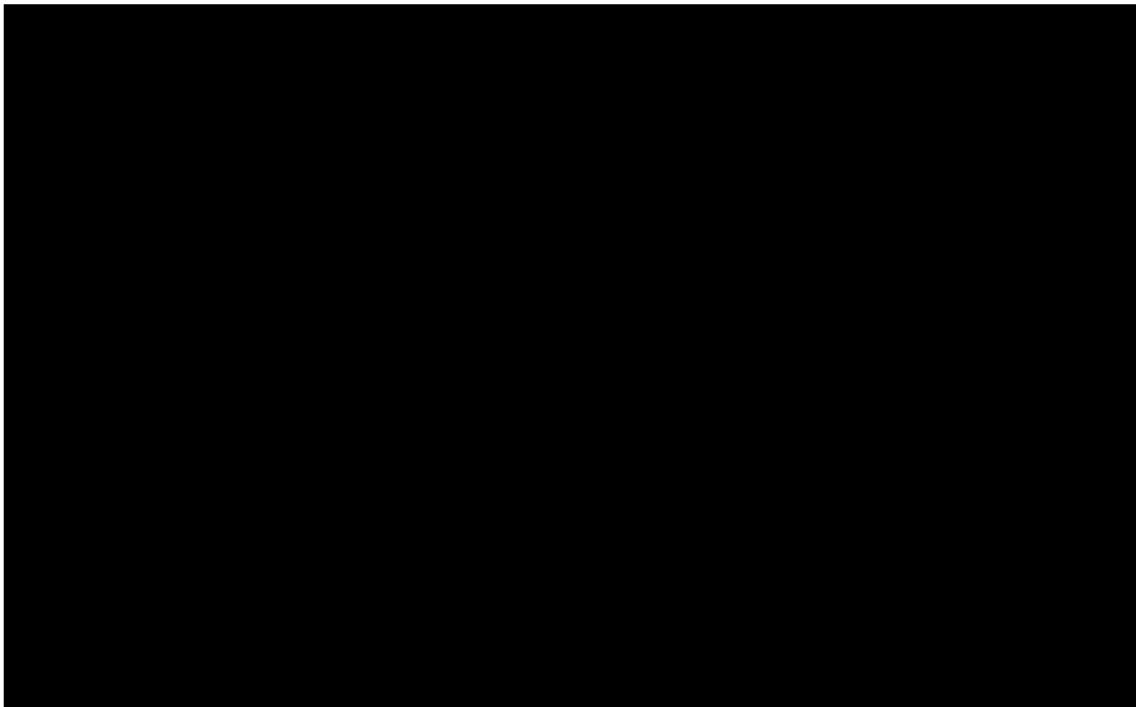

Figure 3. Adjusted survival model extrapolations for all-cause mortality (reproduced from Figure 22 of the CS)



In considerations of the AIC scores, the 95 %CI of the 5-year meta-analysis mortality mean identified by Jones *et al* and alignment of the 10-year observed survival in the Shahim *et al.*, the adjusted Weibull model was chosen to extrapolate CV and all-cause mortality in the company's base case. Further to this, two UK clinical experts were consulted by the company to provide the most plausible estimates for CV and all-cause mortality. They indicated that published data should be preferred but that the Weibull extrapolation was considered the most plausible.

EAG critique

The EAG notes the lengths the company has gone to provide CV and all-cause mortality extrapolations that reflect the true disease pathology. However, the EAG questions the clinical plausibility of the adjusted Weibull survival model, given that for CV mortality (Figure 2) [REDACTED] of the patient cohort had not died due to CV mortality [REDACTED] (and would be 101.67 years old). Likewise, the probability of survival after 30 years for all-cause mortality of the adjusted Weibull extrapolation is also [REDACTED]. It is therefore likely that the adjusted Weibull extrapolation model is greatly underestimating CV mortality of the patient population and mildly underestimating all-cause mortality. This is included as a key issue in Section 1.3 (Issue 3 described in Table 4).

In efforts to externally validate the adjusted survival models, comparisons are made to the SLR and meta-analysis by Jones *et al.* and the multicentre study by Shahim *et al.* In the former study, of the 6 adjusted survival curves only the Gompertz model, the only clinically plausible CV and one of the two clinically plausible all-cause mortality extrapolations, lies outside the 95% CI of the meta-analysed mean after 5 years. However, the latter study validates the Gompertz model at 5 years, showing no alignment with other models, except for the Weibull at 10 years. The study does not go on to outline survival probabilities after 10 years and so no claim can be made to the fitting of the Weibull model post this time point. Overall, there appears to be an inconsistency in the findings of the external studies used to validate and support the use of the Weibull extrapolation in the base case.

While the EAG disagrees with the extrapolation due to its under estimation of CV and all-cause mortality, the company has explored a scenario utilising the Gompertz distribution which reflects a more pessimistic CV and all-cause mortality survival probability which increased the ICER by 25% from £7,519 to £9,590.

Given the poor extrapolation fit may be artifact of extrapolating only part of the mortality data of the DELIVER study and the company did not provide a clinically plausible rationale for the inflection

point in KM curves between the trial arms, the EAG recommended that the company conducted a scenario that extrapolated the mortality data using a single parametric model instead of the piecewise, in efforts of achieving a more generalisable predictor of mortality. The company did not conduct the scenario as requested, reiterating that a single survival model for mortality would be inappropriate for analysis according to NICE DSU TSD14.⁶⁰

As the DELIVER study found [REDACTED] in CV or all-cause mortality between the trial arms ([REDACTED], respectively) and the EAG's clinical experts suggested that "dapagliflozin has no real effect on all-cause/CV mortality" and "were uncertain by which mechanism dapagliflozin would work to reduce CV mortality" the EAG requested that the company conducted an additional scenario that removed the treatment effect of dapagliflozin from CV and all-cause mortality survival curve calculations. The company did not comply with the EAG's request. The EAG therefore conducted the scenario by removing the treatment effect of dapagliflozin from the CV and all-cause mortality survival curve calculations leading to an increase in the ICER from £7,519 to £16,004. On further investigation into the CV mortality treatment effect of dapagliflozin, Table 24, produced by the company in response to clarification question A2, shows that the CV mortality treatment effect found in the DELIVER trial was

[REDACTED]. That is, the population that had previously been diagnosed with HFrEF (LVEF $\leq 40\%$) but have become HFpEF or HFmrEF (LVEF $>40\%$). As patients with HFrEF are eligible for dapagliflozin (according to TA679) and clinical expert opinion provided to the EAG suggests that once HFrEF patients receive treatment they are unlikely to stop treatments (possibly including dapagliflozin) just because their LVEF increases to $>40\%$, the difference between the subgroups with and without a prior LVEF $\leq 40\%$ is important (see Section 3.3.5.1 for further discussion). In the group with a consistent LVEF $>40\%$, point estimates suggest that dapagliflozin [REDACTED] on CV mortality compared to the overall population, while for the group with a prior LVEF $\leq 40\%$ the difference between dapagliflozin and placebo [REDACTED], despite [REDACTED]. This is included as a key issue in Section 1.3 (Issue 4 described in Table 5). While the EAG note that to be included in the DELIVER trial, participants could not have been treated with an SGLT2 inhibitor within 4 weeks prior to randomisation or have previous intolerance to an SGLT2 inhibitor, the EAG's concern is about results from a subgroup potentially already covered by recommendations in TA679 (as they continue to be treated as HFrEF in practice) affecting the results of this trial, with a noticeable difference identified for CV mortality, rather than

a concern that previous SGLT2 use is impacting results from the trial. The EAG also notes that [REDACTED] in terms of CV mortality was also observed in [REDACTED] subgroup (Section 3.3.5.4) compared to the overall population, but this was not a main driver of the decision to remove a CV mortality treatment benefit from the EAG’s base case.

Table 24. Summary of treatment effect for dapagliflozin versus SoC based on prior LVEF status (reproduced from Table 7 of the company’s response to clarification question A7)

CV mortality	HFimpEF (N= [REDACTED])	LVEF > 40% (N= [REDACTED])
Events	[REDACTED]	[REDACTED]
Events per 100 patient years	[REDACTED]	[REDACTED]
Hazard ratio for dapagliflozin versus SoC (95% CI)	[REDACTED]	[REDACTED]
p-value for dapagliflozin versus SoC	[REDACTED]	[REDACTED]

Abbreviations: CI, confidence interval; CV, cardiovascular; HFimpEF, heart failure with an improved ejection fraction; LVEF, left ventricular ejection fraction; SoC, standard of care.

4.2.6.5 Non-CV mortality

To include the outcomes and costs associated with non-CV mortality in the model, non-CV mortality was calculated as the difference between all-cause mortality and CV mortality (non-CV mortality = all-cause mortality – CV mortality).

The company applied the risk of non-CV mortality by taking the maximum risk between the non-CV mortality data captured by the DELIVER trial and non-CV mortality derived from general population life tables. In efforts to avoid mortality rates skewed by the COVID-19 pandemic the company base case incorporated values from 2017-19 instead of the more recent 2018-2020 life tables. Overall all-cause mortality was reduced in patients treated with dapagliflozin compared with placebo, although the difference was [REDACTED] (497 versus 526, respectively; [REDACTED]).

EAG critique

The EAG agrees with the company’s approach to calculating and applying the non-CV related mortality probability but questions if costs and benefits relating to non-CV mortality should be included in the decision model given [REDACTED] was found in all-cause mortality between the trial arms ([REDACTED]). That [REDACTED] was found between treatment and non-CV mortality

aligned with the opinion of independent clinical experts provided to the EAG as they did not consider a reduction in all-cause mortality plausible. As a scenario, the EAG asked the company to recalculate the ICER while excluding non-CV mortality events. The company did not comply with the request stating the limitations in interpreting p-values and reasons other than clinical equivalence being possible. The EAG is aware that the exclusion of costs relating to non-CV mortality is in line with the base case assumptions of the company for TA679 but is in contrast to the advice provided by the EAG of TA679, which looked to include costs related to non-CV mortality.¹

The EAG notes that as the company has calculated non-CV mortality as the difference between all-cause mortality and CV mortality, if treatment with dapagliflozin does provides a benefit to CV mortality as suggested by the company's primary efficacy outcome, then as no difference was found in all-cause mortality between the trial arms over the study period this suggests dapagliflozin must have an equal worsening impact on non-CV mortality.

4.2.7 Health-related quality of life

4.2.7.1 HSUVs

The company derived HSUVs for each KCCQ-TSS quartile using the EQ-5D-5L data collected in the DELIVER trial. EQ-5D-5L data were collected at baseline, Month 8 and the final visit. The company mapped the EQ-5D-5L responses to the EQ-5D-3L using the mapping function developed by Hernandez Alava *et al.* 2017 and the Economic Methods of Evaluation in Health and Social Care Policy Research Unit (EEPRU) dataset reported by Hernandez Alava *et al.* 2020, as per the sources in the revised NICE methods guide published in 2022.^{63, 64} As noted in Section 4.1, none of the studies included in the economic SLR were considered to provide relevant utility data for inclusion in the economic model.

To predict HSUVs the company used linear mixed effects regression models to account for repeated measures and within-patient correlation adjusted for time from baseline, sex, KCCQ-TSS quartile, T2DM at baseline, body mass index, and age. The resulting HSUVs applied in the base case are presented in Table 25.

The company also considered a scenario where the HSUV for KCCQ-TSS Q4 was set equal to general population utility, using age and sex matched UK population norm EQ-5D values from Hernández Alava M *et al.* 2022.⁶⁵ As shown in Table 25, the HSUVs for Q1-Q3 in this scenario were estimated additively. The EAG notes that a similar scenario was undertaken in the previous dapagliflozin and

empagliflozin submissions for HFrEF as their HSUVs for Q4 were also above general population norms.

Table 25. HSUVs used in the economic model (adapted from Tables 45 and 62 of the CS)

Event	Mean	SE
Base case (DELIVER)		
KCCQ-TSS Q1	████	████
KCCQ-TSS Q2	████	████
KCCQ-TSS Q3	████	████
KCCQ-TSS Q4	████	████
Scenario (KCCQ-TSS Q4 equal to general population utility, Q1-Q3 estimated additively)		
KCCQ-TSS Q1*	████████████████████	████
KCCQ-TSS Q2*	████████████████████	████
KCCQ-TSS Q3	████████████████████	████
KCCQ-TSS Q4	████	████
Abbreviations: CS, company submission; HSUV, health state utility value; KCCQ, Kansas City Cardiomyopathy Questionnaire; SE, standard error; TSS, Total Symptom Score.		
*Utilities of █████ and █████ included in the model for Q1 and Q2, which are assumed to be incorrect.		
**Assuming █████ are male and a starting age of █ years		

The company noted that no impact of age on utility was modelled in the base case analysis as the coefficient for age in the regression model was considered extremely small (████). The company also expected the impact of age to be negligible as the model predicted undiscounted life years of 7.8 for SoC. However, the impact of age on utility was explored in scenario analysis, using UK population norm EQ-5D values, as per the methods in Hernández Alava M *et al.* 2022, which increased the ICER to £7,913.

EAG critique

Table 26. Mean HSUVs across the dapagliflozin trials (adapted from Table 45 in the CS)

Event	DELIVER (HFpEF and HFmrEF)	DAPA-HF (HFrEF)
KCCQ-TSS Q1	████	████
KCCQ-TSS Q2	████	████
KCCQ-TSS Q3	████	████
KCCQ-TSS Q4	████	████
Abbreviations: HSUV, health state utility value; HFmrEF, heart failure with a mildly reduced ejection fraction; HFpEF, heart failure with a preserved ejection fraction; HFrEF, heart failure with a reduced ejection fraction; KCCQ, Kansas City Cardiomyopathy Questionnaire; TSS, Total Symptom Score.		

During the clarification stage, the company was asked how their calculations were used to inform the scenario analysis as the HSUVs for Q1-Q3 lacked face validity. For example, the decrements are

calculated between the quartiles rather than from the Q4 quartile and the resulting HSUVs in Q1 and Q2 were substantially higher than the previous dapagliflozin appraisal (Table 26). In response, the company explained there was an error in their calculations and recalculated their population adjusted quartile KCCQ-TSS utility values as shown in Table 27. While the company has recalculated and rectified the issues highlighted by the EAG, they have done so using an additive approach in contrast to doing so multiplicatively, which NICE DSU TSD 12 outlines as more accurate overall in contrast.⁶⁶

The EAG’s clinical experts stated that it is implausible for patients with symptomatic chronic HF to have a better quality of life than the general population of the same age, mirroring the experts advising the committee for TA679. Following this advice, the EAG will employ a HSUV for KCCQ-TSS Q4 equal to general population utility and HSUVs for Q1-Q3 which are estimated multiplicatively in its preferred base case as outlined in Table 27.

Table 27. Alternative HSUVs when Q4 is set equal to the general population utility (adapted from Table 62 in the CS)

Event	TA679	Company original calculations	Company revised calculations	EAG multiplicative (preferred)
KCCQ-TSS Q1	0.541	████████████████████ ████	████████████████████ ████	████████████████████ ████
KCCQ-TSS Q2	0.646	████████████████████ ████	████████████████████ ████	████████████████████ ████
KCCQ-TSS Q3	0.714	████████████████████ ████	████████████████████ ████	████████████████████ ████
KCCQ-TSS Q4	0.774	████	████	████

Abbreviations: CS, company submission; EAG, External Assessment Group; HSUV, health state utility value; KCCQ, Kansas City Cardiomyopathy Questionnaire; TSS, Total Symptom Score.

4.2.7.2 HF events

The company measured utility decrements associated with HF events (HHF and UHFV) in the DELIVER trial to assess the overall impact to HRQoL. As per the methods to estimate HSUVs, these were derived from a linear mixed effects regression model using responses from the EQ-5D-5L questionnaires, mapped to the EQ-5D-3L. The company applied the utility decrements (Table 28) as a one-off utility in the cycle of incidence (i.e., HF events impact HRQoL for 1 month).

Table 28. Utility decrements used for HF events (reproduced from Table 46 of the CS)

HF event	Mean utility decrement	SE
HHF	■	■
UHFV	■	■

Abbreviations: CS, company submission; HF, heart failure; HHF, hospitalisation for heart failure; SE, standard error; UHFV, urgent heart failure visit.

EAG critique

The EAG validated the assumption that HF events impact HRQoL for 1 month with its clinical experts, who considered the impact on patients' HRQoL to be longer. They indicated that the average length of stay in the hospital for HHF for HFpEF and HFmrEF patients is approximately 11 days.

Subsequently, one expert indicated that a reasonable assumption is that 1 day in hospital impacts patients' HRQoL for 1 week after discharge. The other clinical expert indicated that 6 months of impact (as a maximum) could also be plausible. To explore the impact of this uncertainty, the company was asked to provide two alternative scenario analyses during the clarification stage:

- a) HHF events impact patients' HRQoL for 2.75 months after discharge;
- b) HHF events impact patients' HRQoL for 6 months after discharge.

The company carried out the scenarios as requested with the assumption of HHF events impacting a patients HRQoL for 2.75 months resulting in an ICER of £7,372, and for 6 months an ICER of £7,114, in comparison to the base case of £7,519. With the results of these scenarios, the EAG is satisfied that the original 1 month assumed by the company has not overly impacted the ICER in relation to the length of time advised to the EAG from their clinical experts. In the EAG's base case, the assumption that HHF events impact a patients HRQoL for 2.75 months after discharge has been preferred.

4.2.7.3 Adverse events

The company explained that no meaningful estimate of the impact of AEs on utility could be analysed from the DELIVER trial due to a lack of routinely collected utility data, hence, alternative published sources from the literature were sought. The chosen sources and utility decrements used to inform the model are summarised in Table 29. These utility decrements were applied as a one-off utility in the cycle of incidence (i.e., AEs impact HRQoL for 1 month).

Table 29. Utility decrements used for AEs (reproduced from Table 47 of the CS)

AE	Mean utility decrement	SE	Source
AKI	████	████	Results of the mixed effects regression models of utility on patients with CKD conducted as part of the DAPA-CKD trial. ⁶⁷
Amputation	-0.280	0.056	Results of an SLR for utilities in economic modelling of T2DM by Beaudet <i>et al.</i> 2014. ⁶⁸
Fracture	-0.149	0.033	Outcomes of the mixed effects regression models conducted as part of the DAPA-HF trial and presented in McEwan <i>et al.</i> 2020. ⁶⁹
Volume depletion	-0.051	0.012	
UTI	-0.003	0.001	Based on prior NICE appraisals of dapagliflozin in T2DM, a UTI was assumed to incur the same utility decrement in patients with T2DM as in patients with HF and an LVEF >40%. This decrement was derived from a published economic evaluation of interventions for UTIs in women by Barry <i>et al.</i> 1997. ⁷⁰

Abbreviations: AE, adverse event; AKI, acute kidney injury; CKD, chronic kidney disease; CS, company submission; HF, heart failure; LVEF, left ventricular ejection fraction; NICE, National Institute for Health and Care Excellence; SE, standard error; SLR, systematic literature review; T2DM, type 2 diabetes mellitus; UTI, urinary tract infection.

EAG critique

The EAG considers the AE utility decrements and approach comparable to the previous dapagliflozin appraisal (TA679) in that disutilities are applied to the proportion of patients who experience them for one cycle of the model (one month). The EAG is concerned that while this approach may be suitable for transient conditions, disutility for lifetime conditions such as amputations applying for one month and not thereafter will underestimate lifetime impact of this AE on HRQoL. However, as the EAG's base case does not include amputations, this point will not be taken further.

4.2.8 Resource use and cost

4.2.8.1 Treatment acquisition costs

The intervention included in the economic model was dapagliflozin formulated as a 10 mg tablet taken once a day, in addition to SoC. The list price for dapagliflozin is £36.59 for a pack of 28 tablets, amounting to a daily cost of £1.31 and an annual cost of £477.30. When patients discontinue treatment with dapagliflozin in the model, they incur the treatment costs of SoC alone. No patient access scheme for dapagliflozin is in place and no additional tests or investigations are required prior to the administration of dapagliflozin.

The treatment acquisition costs included in the model are summarised in Table 30. As all included treatments are oral treatments, no treatment administration costs were included.

Table 30. Treatment acquisition costs included in the model (reproduced from Table 49 of the CS)

Treatment	Dose per tablet	Dosing schedule	Units per pack	Cost per pack	Annual cost	Source
SoC (furosemide)	40 mg	40 mg once daily	28	£0.14	£1.84	Cost: eMIT 2021 ⁷¹ Dose: SmPC ⁷²
SoC (bumetanide)	1 mg	1 mg once daily	28	£0.72	£9.39	Cost: eMIT 2021 ⁷¹ Dose: SmPC ⁷³
SoC based on a weighted average of furosemide (80%) and bumetanide (20%)					£3.34	Weights: assumption
Dapagliflozin	10 mg	10 mg once daily	28	£36.59	£477.30	Cost: BNF 2022 ⁷⁴ Dose: SmPC ¹⁰
Dapagliflozin + SoC					£480.64	£3.34 + £477.30
Abbreviations: CS, company submission; BNF, British National Formulary; eMIT, electronic medicines information tool; SmPC, Summary of Product Characteristics; SoC, standard of care.						

EAG critique

The EAG considers the sources used to inform the acquisition costs reasonable and the clinical experts advising the EAG agreed with the company's composition of SoC. The EAG also notes that the main driver of incremental costs was additional acquisition costs for dapagliflozin (see Table 37 of Appendix J in the CS).

4.2.8.2 Health state costs

Health state resource use estimates were taken from McMurray *et al.* 2018, as per TA679.⁷⁵ This study included patients with HF and an LVEF $\leq 40\%$, representing a different patient population to those relevant to this appraisal. However, as no appropriate studies were identified describing the burden of disease associated with HF patients and an LVEF $>40\%$ in the economic SLR, McMurray *et al.* 2018 was considered to be the most appropriate source of disease management costs for this appraisal. These resources were valued using the latest PSS Research Unit (PSSRU) unit costs report (2021) and the latest National Schedule of NHS Costs (2020/2021) (hereinafter referred to as NHS Reference Costs).^{76, 77} The resulting annual health state costs are provided in Table 31 and were applied monthly to reflect the cycle length within the model.

As per TA679, the health state costs were constant across the different KCCQ-TSS quartile health states of the model, and increased costs of HF resulting from worsening disease severity were captured as an increasing incidence of HF events (see Section 4.2.6.2).

Table 31. Health state costs included in the model (reproduced from Tables 51 and 52 of the CS)

Resource group	Resource	Frequency (per year)	Unit cost
A&E visits	GP emergency visits	0.14	£39.00 ^a
	A&E referrals	0.01	£170.46 ^b
Outpatient office physician visits	GP visits	13.54	£39.00 ^a
	Cardiologist visits	0.05	£191.12 ^c
	Other physician visits	0.36	£39.00 ^a
Other GP visits or contacts	GP home visits	1.23	£39.00 ^a
	GP nursing home visits	0.19	£39.00 ^a
	GP residential home visits	0.04	£39.00 ^a
	GP phone calls to patients	0.73	£39.00 ^a
	GP visits with third parties	7.27	£39.00 ^a
Total mean annual cost		£927.76	
Total mean monthly cost		£77.31	

Abbreviations: A&E, accident and emergency; CS, company submission; GP, general practitioner; NHS, National Health Service; PSSRU, Personal Social Services Research Unit.

^a PSSRU 2021: Per surgery consultation lasting 9.22 minutes, with direct care staff costs, with qualification costs (Table 10.3b).

^b NHS Reference Costs 2020/21: total outpatient attendance, service code 180: accident and emergency, total cost (consultant and non-consultant led).

^c NHS Reference Costs 2020/21: total outpatient attendance, service code 320: cardiology, total cost (consultant and non-consultant led).

EAG critique

The EAG sought clinical expert opinion on the health state resource use estimates employed by the company. The EAG's clinical experts strongly disagreed with the number of GP visits or contacts assumed by the company. They suggested the HFpEF and HFmrEF populations are more likely to have approximately 6 GP visits or contacts per year instead of the 23.14 GP visits or contacts assumed by the company, due to fewer treatments being available for patients with HFpEF and HFmrEF. To address this, the company was asked to provide a scenario which allows for 6 annual GP visits in addition to the A&E referrals and cardiologist visits. The company conducted the scenario which resulted in an ICER of £6,826. Therefore, while the one-way sensitivity analysis (OWSA) conducted by the company outlines KCCQ-TSS quartile costs, of which GP visits is a majority

contributor, as one of the main parameters to which the ICER is relatively sensitive to. Given the scenario conducted, this parameter may be of lesser consequence if the number of GP visits has been overestimated by the company.

4.2.8.3 HF event costs

The HF event costs included in the model are summarised Table 32. These costs were applied as a one-off cost in the cycle of incidence.

Table 32. Unit costs for HF events (reproduced from Table 50 of the CS)

Event	Unit cost	Source
HHF	£4,093.01	NHS Reference Costs 2020/2021: weighted average of EB03A:EB03E (non-elective long stay). In line with the approach used in TA679. ⁷⁷
UHFV	£737.68	NHS Reference Costs 2020/2021: weighted average of EB03A:EB03E (day case). In line with the approach used in TA679. ⁷⁷

Abbreviations: CS, company submission; HF, heart failure; HHF: hospitalisation for heart failure; NHS, National Health Service; UHFV: urgent heart failure visit.

EAG critique

Although similar currency codes from NHS Reference Costs were used to inform the previous dapagliflozin submission (TA679), the costs are notably higher when the most recent NHS Reference Costs are used. For example, the EAG notes that costs associated with HHF had on average a year-on-year increase of £130.37 from 17/18 (£2,831.72) to 19/20 (£3,092.47), while the difference between 19/20 to 20/21 was £1000.54 (£4,093.01). Similar jumps in values were calculated by the EAG for AEs associated with long term hospital stays such as amputations and fractures. As it is unlikely that inflation is responsible for the jump in cost's the EAG believes that COVID-19 may have had a significant influence. To explore the impact of this uncertainty the company was asked to provide a scenario using the NHS Reference Costs from 2019/20, inflating them to 2020/21 prices. The scenario conducted by the company resulted in the ICER increasing from £7,519 to £8,161 reflecting a difference of £642. This is included as a key issue in Section 1.3 (Issue 5 described in Table 6).

The EAG was also advised by its clinical experts that the average length of stay (LoS) for HHF for a HFpEF and HFmrEF patient would be approximately 11 days. Given that one of the cost codes used by the company (EB03A) is associated with a 53-day stay, the company was asked to provide the mean length of stay for the ■■■ HHF events recorded in the DELIVER trial.⁷⁸ In response, the

company declined to provide these data and stated the provision of the information requested by the EAG would be associated with substantial uncertainty and an unknown potential for bias. The trial was not designed to capture hospital LoS post-randomisation, patients were not randomised at time of hospital submission, death would complicate LoS analysis, and LoS tends to have skewed distribution and differ between regions.

The company was also asked to provide a scenario using the cost code associated with a 13-day stay only (EB03E), using this cost from the NHS References costs 2019/20 inflated to the 20/21 cost year. This scenario produced an ICER of £8,466, reflecting an increase of £947 from the base case. This is included as a key issue in Section 1.3 (Issue 6 described in Table 7).

4.2.8.4 Mortality costs

The mortality costs included in the model are summarised Table 33. These costs were applied as a one-off cost in the cycle of mortality.

Table 33. Unit costs for mortality events (adapted from Table 50 of the CS)

Event	Unit cost	Source
CV mortality	£1,763.39	Alva <i>et al.</i> 2015 based on an analysis of the UK Prospective Diabetes Study (UKPDS) study. Of the values reported in Alva <i>et al.</i> 2015, the cost associated with an MI was conservatively chosen as this was the lowest cost of the available fatal CV events (MI, stroke and IHD). ⁷⁹ Cost inflated to the 2020/2021 cost year using the NHSCII published in the PSSRU. ⁷⁶ In line with the approach used in TA679. ¹
Non-CV mortality	£4,792.39	Georghiou and Bardsley 2014 which represents a weighted average of the cost of GP visits (£147.00), district nursing care (£278.00), local authority-funded social care (£1,010.00) and hospital care (£4,580.00) ⁸⁰ Costs are inflated to the 2020/2021 cost year using the NHSCII published in the PSSRU. ⁷⁶

Abbreviations: CS, company submission; CV, cardiovascular; GP, General Practitioner; HF, heart failure; HHF: hospitalisation for heart failure; IHD, ischemic heart disease; MI, myocardial infarction; NHS, National Health Service; NHSCII, NHS cost inflation index; PSSRU, Personal Social Services Research Unit; UHFV: urgent heart failure visit.

EAG critique

The EAG agrees with the use of CV mortality cost from Alva *et al.* 2015 and non-CV mortality costs from Georghiou and Bardsley 2014, which reflect the CV mortality costs in the previous dapagliflozin submission.^{79, 80}

4.2.8.5 Adverse event costs

The AE costs included in the model are summarised in Table 34. These costs were applied as a one-off cost in the cycle of incidence.

Table 34. Unit costs for AEs (adapted from Table 53 of the CS)

AE	Unit cost	Source
AKI	£3,987.58	NHS Reference Costs 2020/2021: weighted average of non-elective long stay, currency code LA07H to LA07P. ⁷⁷
Amputation	£17,267.42	NHS Reference Costs 2020/2021: weighted average of non-elective long stay, currency code YQ22A to YQ22B.
Fracture	£5,212.21	NHS Reference Costs 2020/2021: weighted average of non-elective long stay, currency code HE11A to HE71D. ⁷⁷
UTI	£39.00	PSSRU 2021: per GP surgery consultation lasting 9.22 minutes, with direct care staff costs, with qualification costs (Table 10.3b). ⁷⁶
Volume depletion	£39.00	PSSRU 2021: per GP surgery consultation lasting 9.22 minutes, with direct care staff costs, with qualification costs (Table 10.3b). ⁷⁶

Abbreviations: AE, adverse event; AKI, acute kidney injury; CS, company submission; GP, general practitioner; NHS, National Health Service; PSSRU, Personal Social Services Research Unit; UTI, urinary tract infection

EAG critique

On investigation into the appropriateness of costing AEs using NHS Reference Costs from 20/21, annual increases from 17/18 to 19/20 were not found to be reflective of those calculated from 19/20 to 20/21. With amputations as an example, the annual increase in cost from 17/18 to 19/20 was £551.26, however from 19/20 to 20/21 the cost increase was calculated as £4,573.13 (£17,267.42 – £12,694.29). As a result, the EAG asked the company to conduct a scenario in which AEs related to non-elective inpatient care are costed using NHS reference costs from 19/20, inflated to the 20/21 cost year using the NHS cost inflation index (NHSCII) based on an inflation rate of 3.08%. The company ran the scenario as described by the EAG, producing an ICER of £8,161. This is included as a key issue in Section 1.3 (Issue 5 described in Table 6).

The EAG notes that the company has also used the total Healthcare Resource Group (HRG) costs from NHS Reference Costs for fractures in TA679 (Table 44 on page 127 of 519 of the TA679 committee papers) but only non-elective long stay costs for this submission, which is generally one of the most expensive hospital settings. The company did not provide a justification for the change in approach to AE cost calculation.

5 Cost effectiveness results

5.1.1 Company's cost effectiveness results

Table 35 presents the cost-effectiveness results of the company's updated (i.e., post clarification) base case deterministic and probabilistic analyses. The company performed probabilistic sensitivity analysis (PSA) to assess the stochastic uncertainty inherent to the parameters in the base case. PSA results are calculated using 1,000 probabilistic outcomes generated using a Monte Carlo simulation.

In the deterministic base case, the incremental difference in costs and quality-adjusted life-years (QALYs) between dapagliflozin and standard of care (SoC) was £1,885 and 0.251 respectively. Resulting in an incremental cost effectiveness ratio (ICER) of £7,519 per quality adjusted life year (QALY). Assuming a willingness to pay threshold (WTP) of £30,000, the net monetary benefit (NMB) was £5,635 and the net health benefit (NHB) was 0.188, reflecting that the overall population health would be increased as a result of the intervention.

Table 35. Company's base case results, post clarification

Interventions	Total Costs	Total LYG	Total QALYs	Incremental costs	Incremental LYG	Incremental QALYs	ICER (£/QALY)
Deterministic results							
Dapagliflozin	£14,352	8.295	5.052	£1,885	0.37	0.251	£7,519
SoC	£12,467	7.925	4.801	-	-	-	-
Probabilistic results							
Dapagliflozin	£14,315	-	4.974	£1,896	-	0.261	£7,276
SoC	£12,419	-	4.714	-	-	-	-
Abbreviations: ICER, incremental cost effectiveness ratio; LYG, life year gained; QALY, quality adjusted life year; SoC, standard of care.							

A PSA scatterplot is presented in Figure 4 and a cost-effectiveness acceptability curve (CEAC) is presented in Figure 5. Based on these analyses, the probability that dapagliflozin is cost effective

compared to SoC is approximately 90% at a WTP threshold of £20,000 and approximately 82% at a threshold of £30,000.

The External Assessment Group (EAG) considers the parameters and respective distributions chosen for PSA to be generally sound. The EAG also considers the probabilistic results to be comparable to the deterministic results.

Figure 4. Cost-effectiveness scatter plot from PSA (reproduced from Figure 13 of the company’s clarification response appendix)

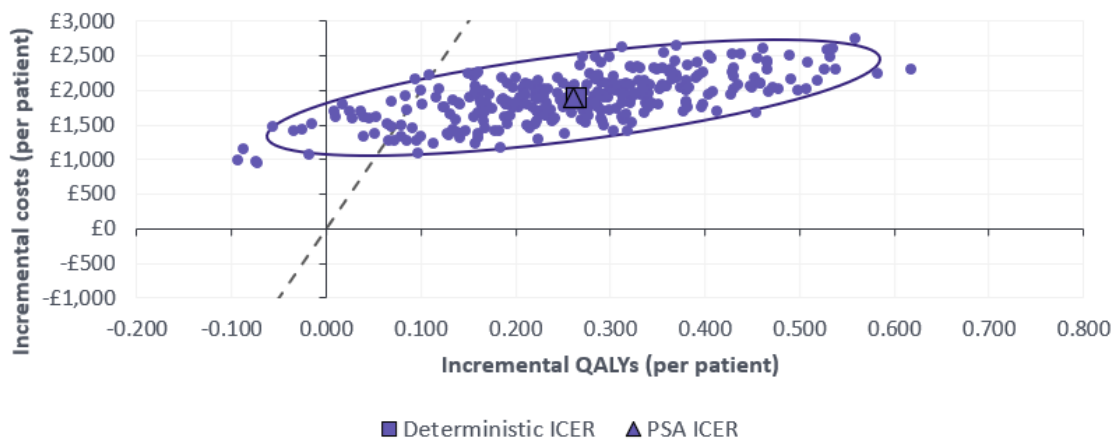

Abbreviations: ICER: incremental cost-effectiveness ratio; QALY: quality-adjusted life year; PSA: probabilistic sensitivity analysis.

Figure 5. Cost effectiveness acceptability curve from PSA (reproduced from Figure 14 of the company’s clarification response appendix)

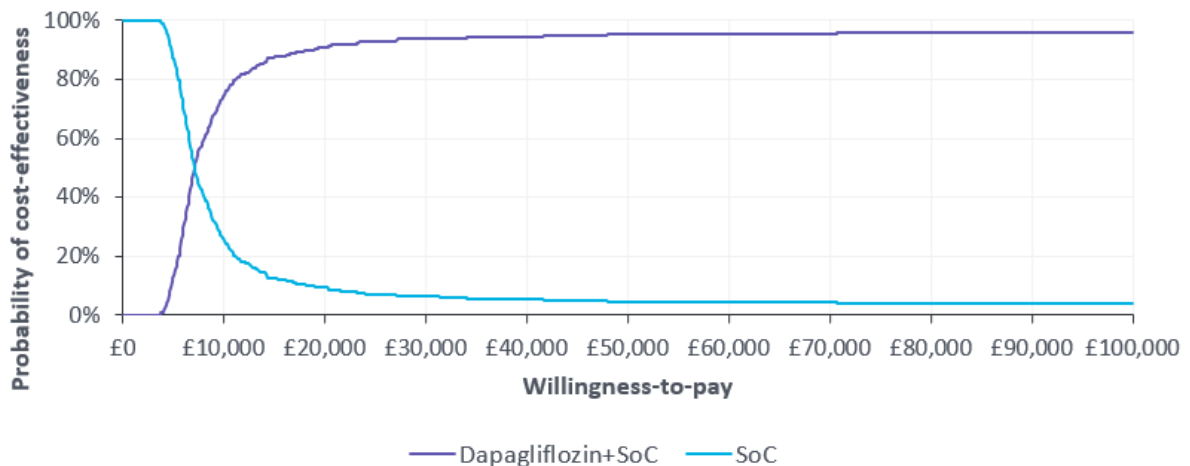

Abbreviations: PSA: probabilistic sensitivity analysis; SoC: standard of care.

5.1.2 Company's sensitivity analyses

5.1.2.1 One-way sensitivity analysis

The company conducted a OWSA to assess the impact to the ICER of varying specific parameters in isolation to identify the main model drivers. The results are illustrated using the tornado diagram in Figure 6. The ICER was most sensitive to cost of hospitalisation for heart failure (HHF) events, followed by the annual probability of amputation for the SoC trial arm and the annual probability of amputation for the dapagliflozin arm.

Figure 6. Tornado plot of OWSA results (reproduced from Figure 28 in the CS)

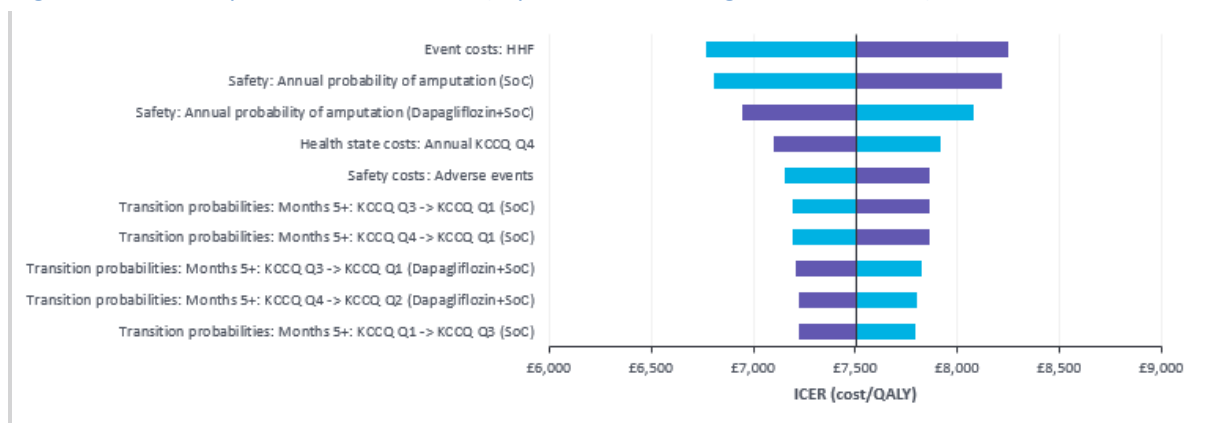

Abbreviations: HHF, hospitalisation for heart failure; ICER, incremental cost-effectiveness ratio; KCCQ-TSS, Kansas City Cardiomyopathy Questionnaire Total Symptom Score; OWSA, one-way sensitivity analyses; SoC, standard of care; QALY, quality-adjusted life year.

Footnotes: Blue = upper ICER; purple = lower ICER.

5.1.2.2 Scenario analysis

The company undertook a series of scenario analyses to assess the impact of applying alternative assumptions to key model parameters. In addition, the company conducted several scenario analyses requested by the EAG. Results of all scenario analyses conducted by the company are presented in Table 36. Several requested scenarios were not provided by the company, as such the EAG have conducted these additional scenario analyses and provided the results in Section 6.3.

Table 36. Company scenario analysis results (reproduced from Figure 31 in the CQ responses)

#	Scenario analysis description	Scenario analysis details	Probabilistic results (for dapagliflozin vs SoC)			Deterministic results (for dapagliflozin vs SoC)		
			Incr. costs	Incr. QALYs	ICER	Incr. costs	Incr. QALYs	ICER
1	Baseline characteristics.	Baseline characteristics were derived from UK CPRD ²⁰ for patients with HF and an LVEF >40%, as detailed in Document B, Section B.3.3.2. The UK CPRD provides baseline characteristics reflective of patients with HF and an LVEF >40% in UK clinical practice; characterising any uncertainty relating to the generalisability of the DELIVER trial to UK clinical practice. ²¹	£1,906	0.237	£8,025	£1,896	0.242	£7,847
2	Risk equations used to model HF events (HHF and UHFV).	This scenario analysis used unadjusted risk equations for HF events, including only treatment as a covariate, were utilised, as detailed in Section B.3.3.7.	£1,895	0.247	£7,681	£1,883	0.251	£7,513

#	Scenario analysis description	Scenario analysis details	Probabilistic results (for dapagliflozin vs SoC)			Deterministic results (for dapagliflozin vs SoC)		
			Incr. costs	Incr. QALYs	ICER	Incr. costs	Incr. QALYs	ICER
3	Risk equations used to model mortality.	Unadjusted Weibull distributions including only treatment as a covariate were utilised for CV and all-cause mortality, as detailed in Section B.3.3.5.	£1,772	0.189	£9,399	£1,750	0.187	£9,362
4	Parametric distributions for both CV-mortality and all-cause mortality.	The exponential distribution was used to model both CV-mortality and all-cause mortality.	£2,169	0.294	£7,369	£2,129	0.290	£7,345
5		The log-normal distribution was used to model both CV-mortality and all-cause mortality.	£2,050	0.216	£9,502	£2,023	0.219	£9,234
6		The log-logistic distribution was used to model both CV-mortality and all-cause mortality.	£1,984	0.235	£8,456	£1,964	0.238	£8,265
7		The Gompertz distribution was used to model both CV-mortality and all-cause mortality.	£1,477	0.155	£9,501	£1,460	0.152	£9,590
8		The Generalised gamma distribution was used to model both CV-mortality and all-cause mortality.	£1,961	0.248	£7,899	£1,943	0.252	£7,702
9	General population mortality.	Survival estimates were not bounded by general population mortality to explore the impact of the approach taken in the base case economic analysis.	£1,900	0.249	£7,644	£1,888	0.252	£7,482
10	Utilities.	Health state utility values were also age-adjusted over the model time horizon using UK population norm values for EQ-5D as reported in the 2014 dataset by the NICE DSU. ³⁵	£1,896	0.234	£8,088	£1,885	0.238	£7,913
11	Cost of non-CV mortality.	The cost of non-CV mortality was set equal to CV mortality.	£1,852	0.247	£7,511	£1,844	0.251	£7,356

#	Scenario analysis description	Scenario analysis details	Probabilistic results (for dapagliflozin vs SoC)			Deterministic results (for dapagliflozin vs SoC)		
			Incr. costs	Incr. QALYs	ICER	Incr. costs	Incr. QALYs	ICER
12	Adverse events.	It was assumed that no AEs were associated with SoC.	£2,754	0.227	£12,156	£2,768	0.232	£11,943
13	Utilities.	The health state utility for KCCQ-TSS Q4 was assumed to be equal to general population utility; the relative decrements between KCCQ-TSS Q1–Q3 and Q4 based on the DELIVER trial data were applied to the general population utility to derive the health state utility values for KCCQ-TSS Q1–Q3. The following KCCQ-TSS health state utilities were therefore used in the scenario: KCCQ-TSS Q1: █████ (SE: █████); KCCQ-TSS Q2: █████ (SE: █████); KCCQ-TSS Q3: █████ (SE: █████); KCCQ-TSS Q4: █████ (SE: █████).	£1,896	0.233	£8,151	£1,885	0.237	£7,955
14	B2	Excluded amputation from the cost effectiveness model.	£2,102	0.241	£8,737	£2,109	0.247	£8,538
15	B3	Use the probability of AEs as in TA679.	£2,080	0.240	£8,656	£2,077	0.246	£8,435
16	B6	Cap the total annual number of GP visits per patient to 6.	£1,727	0.247	£7,001	£1,711	0.251	£6,826
17	B7	Use non-elective long term and day cases NHS References 2019/20 costs inflated to the 20/21 cost year.	£2,059	0.247	£8,348	£2,046	0.251	£8,161
18	B8	Use the NHS cost code EB03E to cost HHF events.	£2,136	0.247	£8,659	£2,122	0.251	£8,466
19	B12a	Assume the disutility from a HHF event persists for 2.75 cycles of the model.	£1,896	0.252	£7,538	£1,885	0.256	£7,372

#	Scenario analysis description	Scenario analysis details	Probabilistic results (for dapagliflozin vs SoC)			Deterministic results (for dapagliflozin vs SoC)		
			Incr. costs	Incr. QALYs	ICER	Incr. costs	Incr. QALYs	ICER
20	B12b	Assume the disutility from a HHF event persists for 6 cycles of the model.	£1,896	0.261	£7,276	£1,885	0.265	£7,114

Abbreviations: AE, adverse event; CPRD, Clinical Practice Research Datalink; CS, company submission; CQ, clarification question; CV, cardiovascular; DSU, Decision Support Unit; EQ-5D, EuroQoL-5 Dimensions; GP, general practitioner; HF, heart failure; HHF, hospitalisation for heart failure; ICER, incremental cost-effectiveness ratio; KCCQ-TSS, Kansas City Cardiomyopathy Questionnaire – Total Symptom Score; LVEF, left ventricular ejection fraction; NHS, National Health Service; NICE, National Institute for Health and Care Excellence; QALY, quality-adjusted life year; SE, standard error; SoC, standard of care; UHFV, urgent heart failure visit; UK, United Kingdom.

5.1.3 Model validation and face validity check

The company consulted an independent health economist not involved in the model conceptualisation or programming to validate the structure of the model. Once developed, the model underwent two further independent quality control and technical validation processes, which included checking the model calculations, standalone formulars, equations and Excel macros programmed in VBA. Two checklists for technical and stress based off the TECH-VER checklist were also used to test the model in addition to the reviewing of scenario analyses to ensure the model generated accurate results which were consistent with input data and extreme values. Consequently, the EAG did not identify any model errors.⁸¹

6 Additional economic analysis undertaken by the EAG

6.1 Model corrections

The External Assessment Group (EAG) did not identify any model corrections.

6.2 Exploratory and sensitivity analyses undertaken by the EAG

In Section 4 of this report, the EAG has described several scenarios which were not explored by the company and those that warrant further exploration. The deterministic scenarios that the EAG has performed are as follows and results are presented in Table 37 below in Section 6.3:

- assuming the rate of urgent heart failure visit (UHFV) is the same in both treatment groups as ██████████ was found in the DELIVER trial (Section 4.2.6.2);
- adjusting Kansas City Cardiomyopathy Questionnaire (KCCQ) quartile utilities values to population estimates using a multiplicative approach (Section 4.2.7.1) as recommended in National Institute for Health and Care Excellence (NICE) DSU TSD 12;
- removal of the cardiovascular (CV) and all-cause mortality CV treatment effects of dapagliflozin in survival curve calculations (Section 4.2.6.4) as ██████████ in the DELIVER trial and the EAG's clinical experts did not consider that dapagliflozin would make a difference to mortality.

6.3 EAG scenario analysis

Table 37. Results of the EAG's scenario analyses

	Results per patient	Dapagliflozin	SoC	Incremental value
0	Company base case			
	Total costs (£)	£14,352	£12,467	£1,885
	QALYs	5.052	4.801	0.251
	ICER (£/QALY)			£7,519
1	Equal rate of UHFV for both treatment arms			
	Total costs (£)	£14,357	£12,467	£1,890
	QALYs	5.052	4.801	0.250
	ICER (£/QALY)			£7,552
2	Multiplicative population adjusted utility values			
	Total costs (£)	£14,352	£12,467	£1,885
	QALYs	4.734	4.499	0.235
	ICER (£/QALY)			£8,006

3	Removal of dapagliflozin treatment effect in CV and non-CV survival curve calculations			
	Total costs (£)	£13,954	£12,467	£1,487
	QALYs	4.894	4.801	0.093
	ICER (£/QALY)			£16,004

Abbreviations: CV, cardiovascular; EAG, External Assessment Group; ICER, incremental cost-effectiveness ratio; QALY, quality adjusted life year; SoC, standard of care; UHFV, urgent heart failure visit.

6.4 EAG preferred assumptions

Table 38 outlines the impact of each EAG preferred assumption on the incremental cost-effectiveness ratio (ICER) with Table 39 presenting the EAG's deterministic and probabilistic base case results. Deterministic scenarios around the EAG base case are presented in Table 40.

In the EAG base case probabilistic analysis, an incremental quality-adjusted life-year (QALY) gain of 0.086 over standard of care (SoC) along with additional costs of £1,974 for the dapagliflozin, generated an ICER of £22,882 per QALY. The net monetary benefit (NMB) using the £30,000 threshold was £606 and the net health benefit (NHB) was 0.0202. Figures 7-9 outline a cost-effectiveness scatterplot, cost-effectiveness acceptability curve (CEAC) and one-way sensitivity analysis (OWSA) using the EAGs base case assumptions.

The EAG considers that the ICERs are highly sensitive due to the small incremental costs and QALY gain, such that small changes cause a substantial impact.

Table 38. EAG's preferred model assumptions

Preferred assumption	Section in EAG report	Cumulative ICER (£/QALY)
Company base case	-	£7,519
Age adjusted utilities	4.2.7.1	£7,913
Multiplicative population adjusted utilities	4.2.7.1	£8,425
Removal of amputation from adverse events	4.2.6.3	£9,584
Non-elective inpatient costs taken from NHS Reference costs 19/20 and inflated to the 20/21 cost year	4.2.8.3	£10,068
HHF disutility applied for 2.75 months	4.2.7.2	£9,844
6 annual GP visits per year	4.2.8.1	£9,072

Code cost associated with shorter HHF LoS used	4.2.8.3	£9,663
Removal of dapagliflozin treatment effects from UHFV event calculations	4.2.6.2	£9,694
Removal of dapagliflozin treatment effects from CV and non-CV survival curve calculations	4.2.6.4	£22,972

Abbreviations: CV, cardiovascular; EAG, External Assessment Group; GP, general practitioner; HHF, hospitalisation for heart failure; ICER, incremental cost-effectiveness ratio; LoS, length of stay; NHS, National Health Service; QALY, quality adjusted life year; UHFV, urgent heart failure visit.

Table 39. EAG's base case

Interventions	Total Costs (£)	Total LY	Total QALYs	Incremental costs (£)	Incremental LYG	Incremental QALYs	ICER (£/QALY)
Deterministic results							
Dapagliflozin	£7,980	7.993	4.427	£1,974	0.068	0.086	£22,972
Soc	£6,006	7.926	4.342	-	-	-	-
Probabilistic results							
Dapagliflozin	£7,963	-	4.413	£1,969	-	0.084	£23,411
Soc	£5,994	-	4.329	-	-	-	-

Abbreviations: EAG, External Assessment Group; ICER, incremental cost effectiveness ratio; LY, life years; LYG, life year gained; QALY, quality adjusted life year; SoC, standard of care.

Table 40. Deterministic scenarios around the EAG base case

	Results per patient	Dapagliflozin	SoC	Incremental value
0	EAG base case			
	Total costs (£)	£7,980	£6,006	£1,974
	QALYs	4.427	4.342	0.086
	ICER (£/QALY)			£22,972
1	EAG preferred assumptions + calculating CV mortality survival using the Gompertz extrapolation			
	Total costs (£)	£6,653	£4,827	£1,826
	QALYs	3.873	3.8	0.072
	ICER (£/QALY)			£25,204

Abbreviations: CV, cardiovascular; EAG, External Assessment Group; ICER, incremental cost effectiveness ratio; QALY, quality adjusted life year; SoC, standard of care.

Figure 7. Cost-effectiveness scatter plot from PSA with the EAGs preferred assumptions

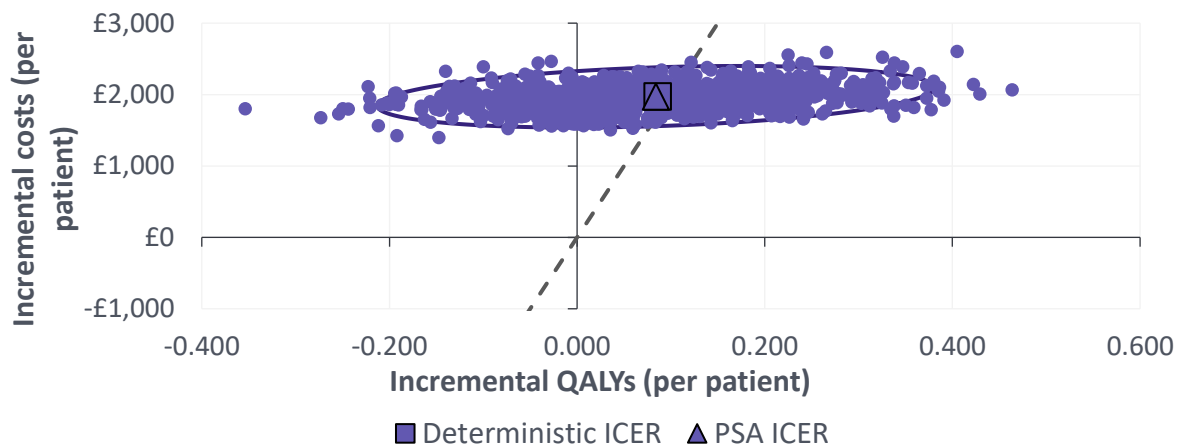

Abbreviations: EAG, External Assessment Group; ICER, incremental cost-effectiveness ratio; PSA, probabilistic sensitivity analysis; QALY, quality adjusted life year.

Figure 8. CEAC from PSA with the EAGs preferred assumptions

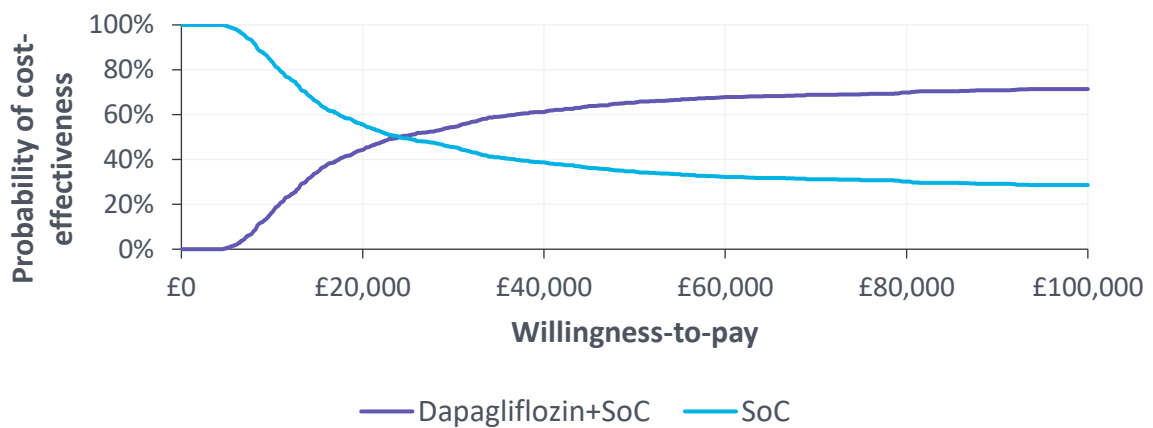

Abbreviations: CEAC, cost-effectiveness acceptability curve; EAG, External Assessment Group; PSA, probabilistic sensitivity analysis; SoC, standard of care.

Figure 9. Tornado plot of OWSA results with the EAGs preferred assumptions

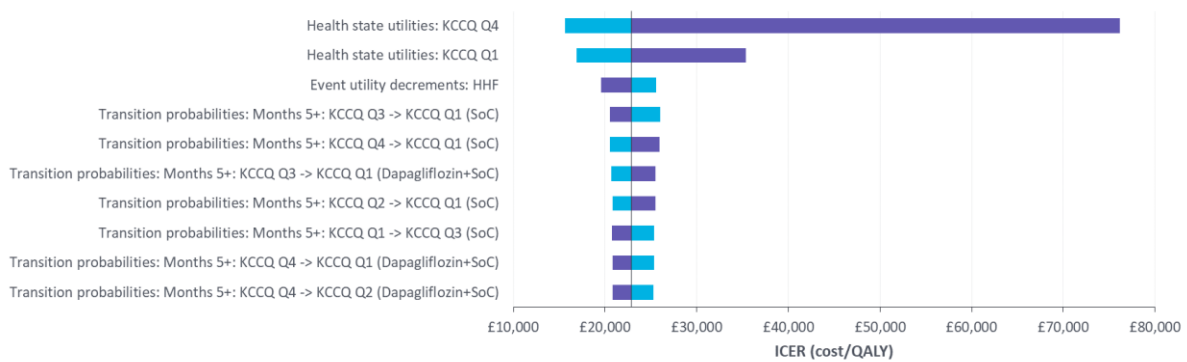

Abbreviations: EAG, External Assessment Group; HHF, hospitalisation for heart failure; ICER, incremental cost-effectiveness ratio; KCCQ, Kansas City Cardiomyopathy Questionnaire; OWSA, one-way sensitivity analysis; SoC, standard of care.

6.5 Conclusions of the cost effectiveness sections

The EAG considers the company's that the submitted cost-effectiveness analysis adheres to the decision problem defined in the NICE final scope. However, the addition of amputations as an adverse event appears inappropriate given the [redacted] rate in both trial arms for patients without type 2 diabetes mellitus. The removal of amputation from the cost effectiveness model increases the ICER, as do many of the other issues the EAG has raised. Collectively the cumulative impact of these issues is modest on the ICER, however, the issue of the mortality treatment effect cannot be overlooked.

From the company's base case of £7,519, the removal of the mortality benefit for dapagliflozin compared to SoC, following [redacted] in the DELIVER trial ([redacted] for CV mortality, [redacted] for all-cause mortality) and the EAGs clinical experts being of the opinion that they wouldn't expect dapagliflozin to influence mortality, raises the ICER to £16,004. When this is further compounded by the EAG's other preferred assumptions the ICER increases beyond the £20,000 cost effectiveness threshold to £22,985 (probabilistic ICER of £23,411).

While not included in the EAG's base case, the EAG conducted a scenario which incorporated the EAG's preferred assumptions in addition to using the Gompertz model to extrapolate CV mortality as the Weibull model used in the company's base case appears to greatly underestimate this parameter (Table 40). The resulting ICER was £25,220 and therefore below the £30,000 cost-

effectiveness threshold. As the Gompertz is likely to provide an over estimation of CV mortality in contrast to the Weibull's underestimation, the EAG considers that if a more generalisable model was used to extrapolate CV and all-cause mortality the ICER would still lie below the £30,000 cost effectiveness threshold.

In the EAG's opinion, for the ICER to drop below the £20,000 cost effectiveness threshold the committee would need to consider if a CV mortality benefit to HFpEF and HFmrEF populations is plausible. In consideration of this, the EAG highlights that the population who [REDACTED] from any CV mortality treatment effect [REDACTED] in the DELIVER trial were those who were previously HFrEF and now HFimpEF ([REDACTED]), compared to those who were initially diagnosed with a left ventricular ejection fraction (LVEF) >40% ([REDACTED]). The EAG views that the heart failure (HF) with improved LVEF (HFimpEF) subpopulation should be considered the same as a "well-treated" HF with reduced LVEF (HFrEF) population, with dapagliflozin already an option for HFrEF in line with TA679.

Independent of the CV mortality treatment effect of dapagliflozin, all ICERs calculated in each given scenario are below the £30,000 cost effectiveness threshold.

7 References

1. National Institute for Health and Care Excellence (NICE). Dapagliflozin for treating chronic heart failure with reduced ejection fraction: Technology appraisal guidance [TA679], 2021. Available from: <https://www.nice.org.uk/guidance/ta679> Date accessed: Sept 2022.
2. National Institute for Health and Care Excellence (NICE). Chronic heart failure in adults: diagnosis and management [NG106], 2018. Available from: <https://www.nice.org.uk/guidance/ng106> Date accessed: Sept 2022.
3. Cleland JGF, Bunting KV, Flather MD, Altman DG, Holmes J, Coats AJS, et al. Beta-blockers for heart failure with reduced, mid-range, and preserved ejection fraction: an individual patient-level analysis of double-blind randomized trials. *Eur Heart J* 2018; **39**: 26-35.
4. Cleland JGF, Tendera M, Adamus J, Freemantle N, Polonski L, Taylor J, et al. The perindopril in elderly people with chronic heart failure (PEP-CHF) study. *European Heart Journal* 2006; **27**: 2338-45.
5. Solomon SD, McMurray JJV, Anand IS, Ge J, Lam CSP, Maggioni AP, et al. Angiotensin–Nepriylsin Inhibition in Heart Failure with Preserved Ejection Fraction. *New England Journal of Medicine* 2019; **381**: 1609-20.
6. Yusuf S, Pfeffer MA, Swedberg K, Granger CB, Held P, McMurray JJV, et al. Effects of candesartan in patients with chronic heart failure and preserved left-ventricular ejection fraction: the CHARM-Preserved Trial. *The Lancet* 2003; **362**: 777-81.
7. Pitt B, Pfeffer MA, Assmann SF, Boineau R, Anand IS, Claggett B, et al. Spironolactone for Heart Failure with Preserved Ejection Fraction. *New England Journal of Medicine* 2014; **370**: 1383-92.
8. Yamamoto K, Origasa H, Hori M. Effects of carvedilol on heart failure with preserved ejection fraction: the Japanese Diastolic Heart Failure Study (J-DHF). *Eur J Heart Fail* 2013; **15**: 110-8.
9. McDonagh TA, Metra M, Adamo M, Gardner RS, Baumbach A, Böhm M, et al. 2021 ESC Guidelines for the diagnosis and treatment of acute and chronic heart failure. *European Heart Journal* 2021: 1-128.
10. Electronic Medicines Compendium (EMC). Forxiga 10 mg film-coated tablets (SmPC), 2022. Available from: <https://www.medicines.org.uk/emc/product/7607/smpc> Date accessed: Sept 2022.
11. Henning RJ. Diagnosis and treatment of heart failure with preserved left ventricular ejection fraction. *World J Cardiol* 2020; **12**: 7-25.
12. Edelmann F, Stahrenberg R, Gelbrich G, Durstewitz K, Angermann CE, Düngen H-D, et al. Contribution of comorbidities to functional impairment is higher in heart failure with preserved than with reduced ejection fraction. *Clinical Research in Cardiology* 2011; **100**: 755-64.
13. Comin-Colet J, Martin Lorenzo T, Gonzalez-Dominguez A, Oliva J, Jimenez Merino S. Impact of non-cardiovascular comorbidities on the quality of life of patients with chronic heart failure: a scoping review. *Health Qual Life Outcomes* 2020; **18**: 329.
14. Lang CC, Mancini DM. Non-cardiac comorbidities in chronic heart failure. *Heart* 2007; **93**: 665-71.
15. Metra M, Zaca V, Parati G, Agostoni P, Bonadies M, Ciccone M, et al. Cardiovascular and noncardiovascular comorbidities in patients with chronic heart failure. *J Cardiovasc Med (Hagerstown)* 2011; **12**: 76-84.
16. National Institute for Health and Care Excellence (NICE). Dapagliflozin in combination therapy for treating type 2 diabetes [TA288]. Available at: <https://www.nice.org.uk/guidance/ta288> [accessed 01 June 2022]. 2016.
17. National Institute for Health and Care Excellence (NICE). Canagliflozin, dapagliflozin and empagliflozin as monotherapies for treating type 2 diabetes [TA390]. Available at: <https://www.nice.org.uk/guidance/ta390> [accessed 01 June 2022]. 2016.

18. National Institute for Health and Care Excellence (NICE). Dapagliflozin in triple therapy for treating type 2 diabetes: Technology appraisal guidance [TA418], 2016. Available from: <https://www.nice.org.uk/guidance/ta418> Date accessed: Sept 2022.
19. National Institute for Health and Care Excellence (NICE). Dapagliflozin for treating chronic kidney disease: Technology appraisal guidance [TA775], 2022. Available from: <https://www.nice.org.uk/guidance/ta775> Date accessed: Sept 2022.
20. Ponikowski P, Voors AA, Anker SD, Bueno H, Cleland JG, Coats AJ, et al. 2016 ESC Guidelines for the diagnosis and treatment of acute and chronic heart failure: The Task Force for the diagnosis and treatment of acute and chronic heart failure of the European Society of Cardiology (ESC). Developed with the special contribution of the Heart Failure Association (HFA) of the ESC. *Eur J Heart Fail* 2016; **18**: 891-975.
21. Chioncel O, Lainscak M, Seferovic PM, Anker SD, Crespo-Leiro MG, Harjola Vp, et al. Epidemiology and one-year outcomes in patients with chronic heart failure and preserved, mid-range and reduced ejection fraction: an analysis of the ESC Heart Failure Long-Term Registry. *European Journal of Heart Failure* 2017; **19**: 1574-85.
22. Banerjee A, Bodegard J, Mamza JB, Thuresson M, Eriksson JW, Norhammar A. Heart Failure Prevalence, Patient Characteristics and Outcomes: A Large Observational Study. Presentation at ESC-HF 2020. 2020. p. ESC-HF 2020; Virtual.
23. Norhammar A, Bodegard J, Thuresson M, Eriksson JW, Bergenheim K. Heart Failure and Health Care Costs: A Full-population Observational Study. Poster presented at HFA Discoveries congress, June 2020. 2020. p. HFA Discoveries Congress; 15-19 June 2020; Virtual.
24. Rangaswami J, Bhalla V, Blair JEA, Chang TI, Costa S, Lentine KL, et al. Cardiorenal Syndrome: Classification, Pathophysiology, Diagnosis, and Treatment Strategies: A Scientific Statement From the American Heart Association. *Circulation* 2019; **139**: e840-e78.
25. Upshaw JN, Konstam MA, Klaveren Dv, Noubary F, Huggins GS, Kent DM. Multistate model to predict heart failure hospitalizations and all-cause mortality in outpatients with heart failure with reduced ejection fraction: model derivation and external validation. *Circulation: Heart Failure* 2016; **9**: e003146.
26. Seferović PM, Petrie MC, Filippatos GS, Anker SD, Rosano G, Bauersachs J, et al. Type 2 diabetes mellitus and heart failure: a position statement from the Heart Failure Association of the European Society of Cardiology. *European journal of heart failure* 2018; **20**: 853-72.
27. Zareini B, Blanche P, D'Souza M, Elmegaard Malik M, Norgaard CH, Selmer C, et al. Type 2 Diabetes Mellitus and Impact of Heart Failure on Prognosis Compared to Other Cardiovascular Diseases: A Nationwide Study. *Circ Cardiovasc Qual Outcomes* 2020; **13**: e006260.
28. Kamalesh M, Cleophas TJ. Heart failure due to systolic dysfunction and mortality in diabetes: pooled analysis of 39,505 subjects. *J Card Fail* 2009; **15**: 305-9.
29. Romero-Gonzalez G, Ravassa S, Gonzalez O, Lorenzo I, Rojas MA, Garcia-Trigo I, et al. Burden and challenges of heart failure in patients with chronic kidney disease. A call to action. *Nefrologia (Engl Ed)* 2020; **40**: 223-36.
30. Sowden E, Hossain M, Chew-Graham C, Blakeman T, Tierney S, Wellwood I, et al. Understanding the management of heart failure with preserved ejection fraction: a qualitative multiperspective study. *Br J Gen Pract* 2020; **70**: e880-e9.
31. Forsyth F, Brimicombe J, Cheriyan J, Edwards D, Hobbs FR, Jalaludeen N, et al. Characteristics of patients with heart failure with preserved ejection fraction in primary care: a cross-sectional analysis. *BJGP Open* 2021; **5**.
32. Zheng A, Cowan E, Mach L, Adam RD, Guha K, Cowburn PJ, et al. Characteristics and outcomes of patients with suspected heart failure referred in line with National Institute for Health and Care Excellence guidance. *Heart* 2020; **106**: 1579-85.

33. AstraZeneca UK Ltd. Data on File. ID: REF-151249 [Summary of clinician interviews to support the NICE HTA submission for HFpEF]. 2022.
34. National Institute for Health and Care Excellence (NICE). Dapagliflozin for treating chronic heart failure with preserved or mildly reduced ejection fraction [Final Scope]. Available at: <https://www.nice.org.uk/guidance/indevelopment/gid-ta10942/documents> [accessed 31 August 2022]. 2022.
35. AstraZeneca UK Ltd. Data on File. ID: REF-156527 [Loop diuretic standard care in HFpEF/mrEF in England]. 2022.
36. Kosiborod MN, Jhund PS, Docherty KF, Diez M, Petrie MC, Verma S, et al. Effects of Dapagliflozin on Symptoms, Function, and Quality of Life in Patients With Heart Failure and Reduced Ejection Fraction: Results From the DAPA-HF Trial. *Circulation* 2020; **141**: 90-9.
37. Higgins JPT, Thomas J, Chandler J, Cumpston M, Li T, Page MJ, et al. Cochrane Handbook for Systematic Reviews of Interventions. 2nd Edition. Chichester (UK). John Wiley & Sons. 2019.
38. Moher D, Liberati A, Tetzlaff J, Altman DG. The PRISMA Group. Preferred Reporting Items for Systematic Reviews and Meta-Analyses: The PRISMA Statement. *PLoS Med* 2009; **6**: e1000097.
39. Solomon SD, McMurray JJV, Claggett B, de Boer RA, DeMets D, Hernandez AF, et al. Dapagliflozin in Heart Failure with Mildly Reduced or Preserved Ejection Fraction. *The New England journal of medicine* 2022.
40. AstraZeneca UK Ltd. An international, double-blind, randomised, placebo-controlled phase III study to evaluate the effect of dapagliflozin on reducing cardiovascular death or worsening heart failure in patients with heart failure with preserved Ejection Fraction (HFpEF): DELIVER - Dapagliflozin Evaluation to Improve the LIVEs of Patients with PReserved Ejection Fraction Heart Failure. 2022.
41. Nassif ME, Windsor SL, Borlaug BA, Kitzman DW, Shah SJ, Tang F, et al. The SGLT2 inhibitor dapagliflozin in heart failure with preserved ejection fraction: a multicenter randomized trial. *Nature Medicine* 2021; **27**: 1954-60.
42. ClinicalTrials.gov. Dapagliflozin in PRESERVED Ejection Fraction Heart Failure (PRESERVED-HF) [NCT03030235]. Available from: <https://clinicaltrials.gov/ct2/show/NCT03030235> [accessed 30 June 2022]. 2021.
43. Trippel TD, Van Linthout S, Westermann D, Lindhorst R, Sandek A, Ernst S, et al. Investigating a biomarker-driven approach to target collagen turnover in diabetic heart failure with preserved ejection fraction patients. Effect of torasemide versus furosemide on serum C-terminal propeptide of procollagen type I (DROP-PIP trial). *Eur J Heart Fail* 2018; **20**: 460-70.
44. Kitada S, Kikuchi S, Tsujino T, Masuyama T, Ohte N. The prognostic value of brain natriuretic peptide in patients with heart failure and left ventricular ejection fraction higher than 60%: a sub-analysis of the J-MELODIC study. *ESC heart failure* 2018; **5(1)**: 36-45.
45. AstraZeneca UK Ltd. Data on File. ID: REF-155912 [UK Clinical Practice Research Datalink (CPRD)]. 2022. 2022.
46. Scottish Intercollegiate Guidelines Network (SIGN). Search Filters. Available at: <https://www.sign.ac.uk/what-we-do/methodology/search-filters/> [Last accessed 13 May 2022]. Available from: <https://www.sign.ac.uk/what-we-do/methodology/search-filters/>. Date accessed.
47. Centre for Reviews and Dissemination. Systematic Reviews: CRD's guidance for undertaking reviews in health care. York: Centre for Reviews and Dissemination, University of York. 2008.
48. Radholm K, Figtree G, Perkovic V, Solomon SD, Mahaffey KW, de Zeeuw D, et al. Canagliflozin and Heart Failure in Type 2 Diabetes Mellitus: Results From the CANVAS Program. *Circulation* 2018; **138**: 458-68.
49. Fitchett D, Zinman B, Wanner C, Lachin JM, Hantel S, Salsali A, et al. Heart failure outcomes with empagliflozin in patients with type 2 diabetes at high cardiovascular risk: results of the EMPA-REG OUTCOME(R) trial. *Eur Heart J* 2016; **37**: 1526-34.

50. Tsaban G, Alnsasra H, Abu-Dogosh A, Weissberg I, Golan Y, Barrett O, et al. Sacubitril/valsartan versus spironolactone in heart failure with preserved ejection fraction; a cost per outcome analysis. *Circulation Conference: American Heart Association's 2021*; **144**.
51. Shantsila E, Shahid F, Sun Y, Deeks J, Calvert M, Fisher JP, et al. Spironolactone in Atrial Fibrillation With Preserved Cardiac Fraction: The IMPRESS-AF Trial. *Journal of the American Heart Association* 2020; **9**: e016239.
52. Lang CC, Smith K, Wingham J, Eyre V, Greaves CJ, Warren FC, et al. A randomised controlled trial of a facilitated home-based rehabilitation intervention in patients with heart failure with preserved ejection fraction and their caregivers: The REACH-HFpEF Pilot Study. *BMJ Open* 2018; **8(4)**.
53. Kitagawa T, Hidaka T, Watanabe N, Naka M, Yamaguchi M, Kanai K, et al. Current conditions and significance of outpatient cardiac rehabilitation and home nursing-care services in heart failure patients with mid-range or preserved ejection fraction: post-hoc analysis of the REAL-HF registry. *Heart and Vessels* 2022; **37(5)**: 745-54.
54. Filippatos G, Maggioni AP, Lam CSP, Pieske-Kraigher E, Butler J, Spertus J, et al. Patient-reported outcomes in the SOLuble guanylate Cyclase stimulator in heArT failure patientS with PRESERVED ejection fraction (SOCRATES-PRESERVED) study. *European Journal of Heart Failure* 2017; **19(6)**: 782-91.
55. Jonsson A, Orwelius L, Dahlstrom U, Kristenson M. Evaluation of the usefulness of EQ-5D as a patient-reported outcome measure using the Paretian classification of health change among patients with chronic heart failure. *J* 2020; **4**: 50.
56. National Institute for Health and Care Excellence (NICE). Empagliflozin for treating chronic heart failure with reduced ejection fraction: Technology appraisal guidance (TA773), 2022. Available from: <https://www.nice.org.uk/guidance/ta773>. Date accessed: Sept 2022.
57. McMurray JJV, Solomon SD, Inzucchi SE, Kober L, Kosiborod MN, Martinez FA, et al. Dapagliflozin in Patients with Heart Failure and Reduced Ejection Fraction. *The New England journal of medicine* 2019; **381**: 1995-2008.
58. Heyward J, Mansour O, Olson L, Singh S, Alexander GC. Association between sodium-glucose cotransporter 2 (SGLT2) inhibitors and lower extremity amputation: A systematic review and meta-analysis. *PLoS One* 2020; **15**: e0234065.
59. Anker SD, Butler J, Filippatos G, Ferreira JP, Bocchi E, Bohm M, et al. Empagliflozin in Heart Failure with a Preserved Ejection Fraction. *The New England journal of medicine* 2021; **385**: 1451-61.
60. Latimer N. NICE DSU Technical Support Document 14: Undertaking survival analysis for economic evaluations alongside clinical trials - extrapolation with patient-level data. Available at: <http://www.nicedsu.org.uk/> [accessed 22 August 2022]. 2011.
61. Jones NR, Roalfe AK, Adoki I, Hobbs FDR, Taylor CJ. Survival of patients with chronic heart failure in the community: a systematic review and meta-analysis. *Eur J Heart Fail* 2019; **21**: 1306-25.
62. Shahim A, Hourqueig M, Donal E, Oger E, Venkateshvaran A, Daubert JC, et al. Predictors of long-term outcome in heart failure with preserved ejection fraction: a follow-up from the KaRen study. *ESC Heart Fail* 2021; **8**: 4243-54.
63. Hernández-Alava M, Pudney S. Econometric modelling of multiple self-reports of health states: The switch from EQ-5D-3L to EQ-5D-5L in evaluating drug therapies for rheumatoid arthritis. *J Health Econ* 2017; **55**: 139-52.
64. Hernández Alava MPS, Wailoo A. Estimating the relationship between EQ-5D-5L and EQ-5D-3L: results from an English population study. Policy Research Unit in Economic Evaluation of Health and Care Interventions. Universities of Sheffield and York. *Report 063* 2020.
65. Hernández Alava M, S. P, E. WA. NICE DSU Report. Estimating EQ-5D by age and sex for the UK., 2022. Available from: <https://nicedsu.sites.sheffield.ac.uk/methods-development/estimating-eq-5d-by-age-and-sex-for-the-uk>. Date accessed: Sept 2022.

66. Ara R, Wailoo AJ. NICE DSU Technical Support Document 12: The use of health state utility values in decision models, 2011. Available from: <https://www.sheffield.ac.uk/nice-dsu/tsds/utilities>. Date accessed: Sept 2022.
67. AstraZeneca. Data on, File. Clinical Study Report. A study to evaluate the effect of dapagliflozin on renal outcomes and cardiovascular mortality in patients with chronic kidney disease (DAPA-CKD). 2020.
68. Beaudet A, Clegg J, Thuresson PO, Lloyd A, McEwan P. Review of utility values for economic modeling in type 2 diabetes. *Value in health : the journal of the International Society for Pharmacoeconomics and Outcomes Research* 2014; **17**: 462-70.
69. McEwan P, Darlington O, McMurray JJV, Jhund PS, Docherty KF, Böhm M, et al. Cost-effectiveness of dapagliflozin as a treatment for heart failure with reduced ejection fraction: a multinational health-economic analysis of DAPA-HF. *Eur J Heart Fail* 2020; **22**: 2147-56.
70. Barry HC, Ebell MH, Hickner J. Evaluation of suspected urinary tract infection in ambulatory women : A cost-utility analysis of office-based strategies. *Journal of Family Practice* 1997; **44**: 49-60.
71. Department of Health and Social Care. Drugs and pharmaceutical electronic market information tool (eMIT). 2021. Available from: <https://www.gov.uk/government/publications/drugs-and-pharmaceutical-electronic-market-information-emit>. Date accessed: Sept 2022.
72. Electronic Medicines Compendium (EMC). Furosemide 40mg Tablets. Summary of Product Characteristics (SmPC), 2016. Available from: <https://www.medicines.org.uk/emc/product/6012/smpc> Date accessed: Sept 2022.
73. Electronic Medicines Compendium (EMC). Bumetanide 1 mg Tablets. Summary of Product Characteristics (SmPC), 2018. Available from: <https://www.medicines.org.uk/emc/product/2542/smpc> Date accessed: Sept 2022.
74. British National Formulary (BNF). Dapagliflozin Medicinal Form. Available from: <https://bnf.nice.org.uk/medicinal-forms/dapagliflozin.html>. Date accessed: Sept 2022.
75. McMurray JJV, Trueman D, Hancock E, Cowie MR, Briggs A, Taylor M, et al. Cost-effectiveness of sacubitril/valsartan in the treatment of heart failure with reduced ejection fraction. *Heart* 2018; **104**: 1006-13.
76. Jones K, Burns A. Unit Costs of Health and Social Care 2021. Personal Social Services Research, Unit., 2021. Available from: <https://kar.kent.ac.uk/92342/19/Unit%20Costs%20Report%202021%20-%20Final%20version%20for%20publication.pdf> Date accessed: Sept 2022.
77. NHS England. National Cost Collection for the NHS., 2020. Available from: <https://www.england.nhs.uk/national-cost-collection/> Date accessed: Sept 2022.
78. NHS England. National Tariff Payment Systems, 2021. Available from: <https://www.england.nhs.uk/pay-syst/national-tariff/national-tariff-payment-system/>. Date accessed.
79. Alva ML, Gray A, Mihaylova B, Leal J, Holman RR. The impact of diabetes-related complications on healthcare costs: new results from the UKPDS (UKPDS 84). *Diabetic Medicine* 2015; **32**: 459-66.
80. Georghiou, Bardsley. Nuffield Trust. Exploring the cost of care at the end of life., 2014. Available from: <https://www.nuffieldtrust.org.uk/research/exploring-the-cost-of-care-at-the-end-of-life>. Date accessed: Sept 2022.
81. Buyukkaramikli NC, Rutten-van Molken M, Severens JL, Al M. TECH-VER: A Verification Checklist to Reduce Errors in Models and Improve Their Credibility. *Pharmacoeconomics* 2019; **37**: 1391-408.
82. Selvaraj S, Vaduganathan M, Claggett Brian L, Miao Zi M, Fang James C, Vardeny O, et al. Blood Pressure and Dapagliflozin in Heart Failure with Mildly Reduced or Preserved Ejection Fraction: DELIVER. *JACC: Heart Failure*.

83. Adamson C, Kondo T, Jhund PS, de Boer RA, Cabrera Honorio JW, Claggett B, et al. Dapagliflozin for heart failure according to body mass index: the DELIVER trial *European Heart Journal* 2022; **43**: 4406-17.

8 Appendices

8.1 Additional subgroup strategies

The sections below provide a discussion of two other subgroup strategies that were queried at clarification (clarification question A4) but did not subsequently provide further rationale for any decisions made by the External Assessment Group (EAG) about the economic model, including systolic blood pressure (SBP) categories and body mass index (BMI) categories. Subgroup strategies that provided further rationale for decisions made by the EAG about the economic model and/or were queried at clarification based on possible treatment differences in clinical practice and a clinical rationale for potential differences in efficacy are discussed in Section 3.3.5.

8.1.1 SBP ≤ 128 mmHg vs >128 mmHg

There were [REDACTED] for the subgroup based on SBP ≤ 128 mmHg vs >128 mmHg, with [REDACTED] observed for the lower SBP group for the composite outcome [REDACTED], but both of these groups are relevant to the appraisal population and focus on the overall full analysis set (FAS) population is, therefore, appropriate.

Results are summarised in Table 41 below. The EAG notes that more substantial differences between subgroups in terms of point estimates were observed for the composite outcome [REDACTED] with [REDACTED] identified for the SBP >128 mmHg group but not the SBP ≤ 128 mmHg group. While the point estimate in terms of [REDACTED] was also [REDACTED] in the SBP >128 mmHg group, a [REDACTED]

While the EAG highlights these [REDACTED] based on data from the company submission (CS) and clinical study report (CSR), the EAG's clinical experts are unaware of a clinical rationale that could readily explain these results. The company also highlights an analysis where they concluded that [REDACTED] various outcomes in the DELIVER trial, including the [REDACTED]; however, the EAG notes that [REDACTED] [REDACTED] is mentioned in this paper, as well as [REDACTED].⁸²

Table 41. Outcomes of interest for SBP ≤128 mmHg vs >128 mmHg subgroups

Outcome	Dapagliflozin + SoC Number with events (event rate)	Placebo + SoC Number with events/number analysed (event rate)	HR (95% CI; p-value)	Interaction p-value (vs >128 mmHg group)
≤128 mmHg group (n=1568 vs n=1590)				
Composite of CV mortality and HF events	████████	████████	████████	██████
CV mortality	████████	████████	████████	██████
HF events	████████	████████	████████	██████
>128 mmHg group (n=1563 vs n=1542)				
Composite of CV mortality and HF events	████████	████████	████████	N/A
CV mortality	████████	████████	████████	N/A
HF events	████████	████████	████████	N/A
Overall FAS population (n=3131 vs n=3132)				
Composite of CV mortality and HF events	████████	████████	0.82 (0.73 to 0.92; p=██████)	N/A
CV mortality	231 ██████	261 ██████	0.88 (0.74 to 1.05; p=██████)	N/A
HF events	████████	████████	████████	N/A
Abbreviations: CI, confidence interval; CV, cardiovascular; FAS, full analysis set; HF, heart failure; HHF, hospitalisation for heart failure; HR, hazard ratio; N/A, not applicable; SBP, systolic blood pressure; SoC, standard of care; T2DM, type 2 diabetes mellitus; UHFV, urgent heart failure visit.				
██				
██				
██				
██				

8.1.2 BMI ≥30 kg/m² vs <30 kg/m²

Results for hazard ratios (HRs) in the CS and CSR indicate that the group with a BMI ≥30 kg/m² may experience ██ compared to the group with a BMI <30 kg/m² in terms of the composite outcome (HR 0.74 [95% CI: 0.63 to 0.88; ██████████] vs

[REDACTED]) and [REDACTED] (HR [REDACTED] vs [REDACTED]), with differences between dapagliflozin and placebo for these outcomes being [REDACTED] in the higher BMI group but not in the lower BMI group. The company also describes additional analyses presented in a paper that support [REDACTED] for outcomes across BMI categories, although the EAG notes that for some that there is the [REDACTED] in groups with a higher BMI.⁸³ The company do, however, highlight that this paper indicates that patients with obesity may experience greater improvement with dapagliflozin in terms of Kansas City Cardiomyopathy Questionnaire Total Symptom Score (KCCQ-TSS) change from baseline score compared to those without obesity, with a significant interaction p-value reported (p=0.03), and an increased reduction in weight was also observed in those that were obese.⁸³

While there is a signal that BMI may affect the [REDACTED], the EAG considers use of the overall FAS population to be appropriate given those with any BMI are relevant to the appraisal population.

Single Technology Appraisal

Dapagliflozin for treating chronic heart failure with preserved or mildly reduced ejection fraction [ID1648]

EAG report – factual accuracy check and confidential information check

“Data owners may be asked to check that confidential information is correctly marked in documents created by others in the evaluation before release.” (Section 5.4.9, [NICE health technology evaluations: the manual](#)).

You are asked to check the EAG report to ensure there are no factual inaccuracies or errors in the marking of confidential information contained within it. The document should act as a method of detailing any inaccuracies found and how they should be corrected.

If you do identify any factual inaccuracies or errors in the marking of confidential information, you must inform NICE by **5pm on Monday 5 December** using the below comments table.

All factual errors will be highlighted in a report and presented to the Appraisal Committee and will subsequently be published on the NICE website with the committee papers.

Please underline all confidential information, and separately highlight information that is submitted as 'commercial in confidence' in turquoise, all information submitted as 'academic in confidence' in yellow, and all information submitted as 'depersonalised data' in pink.

Issue 1 EAG’s interpretation of the statistical results from the DELIVER trial

Description of problem	Description of proposed amendment	Justification for amendment	EAG response
<p>Throughout the report, the EAG make a number of conclusions of clinical equivalence between dapagliflozin and placebo, based on p-values >0.05.</p> <p>The EAG also state that significant differences in terms of CV mortality were only observed in the subgroup of patients with a prior LVEF <40%, and go on to suggest that this interpretation means that dapagliflozin only provides a treatment benefit with respect to CV mortality in this patient subgroup.</p> <p>Based on these interpretations throughout the report, the EAG conclude that endpoints should only be modelled based on statistically significant differences.</p>	<p>For the reasons previously detailed in response to Clarification Question B14–B16, these conclusions are inappropriate and inaccurate. As such, the Company requests for these to be amended throughout the EAG report to provide a more appropriate interpretation of the results of the DELIVER trial and subsequently the methods for modelling endpoints.</p> <p>In particular, inaccurate conclusions that dapagliflozin does not have any effect on CV mortality versus placebo, or that dapagliflozin is only effective for patients with HF and a prior LVEF <40%, should be removed throughout the report.</p>	<p>The EAG’s interpretation that a p-value >0.05 means that dapagliflozin and SoC are clinically equivalent with respect to a number of the endpoints in the DELIVER trial, including cardiovascular (CV) mortality, all-cause mortality and urgent heart failure visit (UHFV) incidence, is incorrect. Publication of the EAG’s interpretation could result in misinformation and result in inaccurate interpretation of the DELIVER clinical trial results.</p> <p>As previously detailed in the Company’s response to Clarification Questions B14–B16, the DELIVER trial was powered to detect statistically significant differences with respect to the primary composite endpoint in the intention-to-treat (ITT) population of the DELIVER trial.</p> <p>The DELIVER trial was not powered to detect statistically significant differences in the individual components of the primary composite endpoint, such as CV mortality, in either the ITT population or any subgroups, including the population of patients with a prior LVEF <40%. It should also be noted that many of these variables</p>	<p>This is not a factual inaccuracy and therefore no changes to the report are required.</p> <p>The EAG has been clear in the report that while point estimates may suggest benefits for certain outcomes, the difference is not statistically significant. The EAG has also acknowledged the limitations of subgroup analyses in the report and considers that results for the EAG’s preferred conclusions and the company’s preferred conclusions, in terms of inclusion of outcomes in the economic model, are covered in the report.</p>

		<p>share competing risk, which must be considered when attempting to analyse any of these endpoints in isolation.</p> <p>Given this, attempting to draw conclusions regarding statistically significant differences between dapagliflozin versus placebo for these endpoints is therefore associated with substantial uncertainty and limitations. Concluding that dapagliflozin and placebo are clinically equivalent with respect to these endpoints based on p-values >0.05 is statistically incorrect. Concluding that dapagliflozin only reduces CV mortality for patients with a prior LVEF <40%, solely on the basis of a p-value <0.05 in this subgroup and a p-value >0.05 in the other group, when neither group was powered for statistical significance, is statistically inappropriate and incorrect.</p> <p>Similarly, resulting conclusions that a treatment effect should only be included in the economic model for endpoints where the p-value is <0.05 are highly flawed. As previously detailed in response to Clarification Questions B14–B16, this approach fundamentally violates core principles in health economic modelling, as well as the NICE methods manual which indicates a preference for the use of randomised controlled trial data to inform relative treatment effects.</p>	
--	--	---	--

		<p>For these reasons, the Company maintains the response to Clarification Questions B14–B16, that the use of the observed data from the DELIVER trial to inform the economic model represents the most appropriate methodology, versus assuming equivalence in any case where a p-value >0.05 is observed.</p> <p>Given the clear uncertainty and limitations associated with the EAG's conclusions, the Company kindly requests the EAG to amend their interpretations of the DELIVER trial data and associated conclusions throughout the report, to provide a more statistically robust interpretation of the results of the DELIVER trial.</p>	
--	--	---	--

Issue 2 Consideration of the HFimpEF population in the DELIVER trial

Description of problem	Description of proposed amendment	Justification for amendment	EAG response
<p>Throughout the report, the EAG make a number of conclusions regarding the inclusion of the HFimpEF group in the DELIVER trial, stating that the treatment effect observed in data is predominantly driven by the HFimpPEF population and that this group usually continue to be treated as if they had HFrefEF, possibly even receiving</p>	<p>The Company requests that the EAG reconsider the emphasis placed on the HFimpEF population as the</p>	<p>The Company feel that undue emphasis has been placed on the HFimpEF population. The Company believes that the EAG are indirectly conducting analyses to assess the</p>	<p>This is not a factual inaccuracy and therefore no major changes to the report are required. Minor edits to wording have been made in sections highlighted by the company.</p>

Description of problem	Description of proposed amendment	Justification for amendment	EAG response
<p>dapagliflozin if it had been initiated when they were considered to have HFrEF.</p> <p>Examples include:</p> <p>On Page 29, the EAG report states:</p> <p><i>The EAG highlights the inclusion of the HFimpEF group in DELIVER, which was explored at clarification given this group usually continue to be treated as if they were HFrEF.</i></p> <p>On Page 32:</p> <p><i>...inclusion of the HFimpEF group in the trial. This group is defined as those who have previously had an LVEF of ≤40% that has since improved to be >40% and comprised █ of the overall trial population in DELIVER.</i></p> <p>On Page 39, the EAG report states:</p> <p><i>Although the HFimpEF group (as noted above in Section 2.3.1) usually continue to be treated as if they are HFrEF</i></p> <p>On Page 60:</p> <p><i>Although those with a prior LVEF ≤40% that has since improved to be >40% (HFimpEF) may be treated as HFrEF, they now have an LVEF >40% and may be an important group if not already receiving dapagliflozin when their LVEF was ≤40%.</i></p>	<p>conclusions drawn are inaccurate.</p> <p>The Company also request that the content of the report should be amended throughout to denote the clear distinction between treatment options for patients with HFimpEF in UK clinical practice; compared to patients with HFimpEF in the DELIVER trial.</p>	<p>relevant cost-effectiveness of dapagliflozin through the exclusion of any treatment effect inferred to by the HFimpEF population.</p> <p>This potential subgroup analysis is completely inappropriate. The Company would like to highlight the appeal for TA504 in which the consideration of subgroups was challenged by the appellant. The conclusions of the appeals highlighted that: <i>“Unless a scope specifies otherwise, the Appeal Panel considers that there is a soft presumption that the starting point for any Committee should be consideration of the whole patient group as one, with a view to making one recommendation for that group.”</i></p> <p>Where different recommendations are to be made for different groups of patients, the reason for departing from one</p>	<p>The EAG is not proposing that this subgroup be excluded. Information from this subgroup has, however, been used to inform the decision about CV mortality in the base case.</p> <p>The concern in terms of existing recommendations relates to the HFrEF group already having a recommendation (and how appropriate it is that a group that may already be covered by this recommendation [HFimpEF, which in practice continue to be treated as HFrEF] influences results in this trial), rather than a concern that patients in the DELIVER trial were already receiving a SGLT-2 inhibitor (which the EAG is aware was not the case).</p>

Description of problem	Description of proposed amendment	Justification for amendment	EAG response
<p>On Page 70:</p> <p><i>The EAG highlights the inclusion of HFimpEF group in the DELIVER trial, which is a group that in clinical practice would continue treatments initiated for HFrEF based on feedback from the EAG's clinical experts, possibly including dapagliflozin if it had been initiated when they were considered to have HFrEF.</i></p> <p>On Page 93:</p> <p><i>Table 25, produced by the company in response to clarification question A2, shows that the CV mortality treatment effect found in the DELIVER trial was</i></p> <p><i>[REDACTED]</i></p> <p><i>That is, the population that had previously been diagnosed with HFrEF (LVEF ≤40%) but have become HFpEF or HFmrEF (LVEF >40%).</i></p> <p><i>As patients with HFrEF are eligible for dapagliflozin (according to TA679) and clinical expert opinion provided to the EAG suggests that once HFrEF patients receive treatment they are unlikely to stop treatments (possibly including dapagliflozin) just because their LVEF increases to >40%, the difference between the subgroups with and without a prior LVEF ≤40% is important</i></p>		<p>recommendation should be clear and adequate, and as far as the reasonableness of considering subgroups is concerned, the Panel tended to agree with Meindert Boysen that in a case where it appeared that use of a product was acceptably cost-effective in a whole population, it would not normally be reasonable to look for subgroups within that population where use was cost-ineffective.</p> <p>However, it would go too far to make that a general rule. Hypothetically if a Committee was aware that there existed an identifiable subgroup defined for a proper purpose and in a logical way and in which use of a particular therapy was clearly not cost-effective, then it might be difficult to say that taking account of that subgroup was unreasonable.</p>	

Description of problem	Description of proposed amendment	Justification for amendment	EAG response
		<p>Nevertheless, in this case, whereby the only evidence supporting the consideration of this subgroup is a <i>post-hoc</i> analysis, which still demonstrates that dapagliflozin may reduce CV mortality compared to placebo (CV mortality HR between dapagliflozin versus placebo is █████ in the prior LVEF >40% subgroup; Table 7 in response to CQ A3), the use of a subgroup analysis is inherently flawed and underestimates the cost-effectiveness of dapagliflozin.</p> <p>Furthermore, as previously detailed, the Company acknowledges that in UK clinical practice, patients with HFimpEF may continue with treatments initiated to treat HFrEF, even when their LVEF increases to >40%, based on clinical guideline recommendations.</p>	

Description of problem	Description of proposed amendment	Justification for amendment	EAG response
		<p>However, it is important to note the distinction between potential UK clinical practice, and the inclusion/exclusion criteria of the DELIVER trial.</p> <p>In the DELIVER trial, all patients were required to adhere to the following criteria with regard to diagnosis and previous treatments.</p> <ul style="list-style-type: none"> • Have a documented diagnosis of symptomatic heart failure (NYHA class II-IV) at enrolment, and a medical history of typical symptoms/signs of heart failure ≥ 6 weeks before enrolment with at least intermittent need for diuretic treatment. • Not receiving therapy with an SGLT2 inhibitor within 4 weeks prior to randomisation or 	

Description of problem	Description of proposed amendment	Justification for amendment	EAG response
		<p>previous intolerance to an SGLT2 inhibitor.</p> <p>Based on these inclusion/exclusion criteria, it is clear that the treatment benefit observed in this HFimpEF patient population cannot be attributed to previous SLGT2 inhibitor treatment, as the EAG suggest. Dapagliflozin is a once daily treatment; patients in the trial did not receive treatment with an SGLT2 inhibitor at least 4 weeks prior to randomisation.</p>	

Issue 3 Previous treatments for patients with HFimpEF in UK clinical practice

Description of problem	Description of proposed amendment	Justification for amendment	EAG response
<p>On page 24, the EAG report states:</p> <p><i>The EAG notes that the company appear to contradict their statement</i></p>	<p>The Company kindly requests that these statements are removed.</p>	<p>These statements in the EAG report misinterpret the Company's response to Clarification Question A3.</p> <p>In Clarification Question A3, the Company stated that "<i>there is a risk</i></p>	<p>The EAG thanks the company for the additional information and has adjusted the wording accordingly.</p>

Description of problem	Description of proposed amendment	Justification for amendment	EAG response
<p><i>in the original CS (Section B.2.3.2) that those with a prior LVEF ≤40% would continue with treatments initiated for HFrEF, as they suggest in their response to clarification question A3 that treatments used when the patient had an LVEF ≤40% would be discontinued.</i></p> <p>On Page 36, the EAG report states:</p> <p><i>As noted above in Section 2.2.1, while the company acknowledge this in the CS, their response to clarification question A3 suggests that treatments initiated for HFrEF would be discontinued if LVEF improved to >40%.</i></p>		<p><i>that patients who previously had HF and a prior LVEF ≤40% but subsequently experienced an improvement in EF, may then discontinue their treatment for HF and an LVEF <40%.”</i></p> <p>In comparison, in Section B.2.3.3 of the Company Submission, it was stated that; “over 18% of patients with HFimpEF, in whom clinical guidelines recommend to continue with treatments initiated to treat HFrEF even when their LVEF increases to >40%.”</p> <p>There is no contradiction between these two statements. Whilst clinical guidelines recommend that treatments initiated for HFrEF are continued, there is nevertheless a risk that patients may discontinue this treatment, as acknowledged in response to Clarification Question A3.</p> <p>The response to Clarification Question A3 does not suggest that all patients would discontinue their treatment, as the EAG suggests. Therefore, the Company would kindly ask the EAG to remove these statements.</p>	

Issue 4 Non-CV mortality

Description of problem	Description of proposed amendment	Justification for amendment	EAG response
<p>On Page 90, the EAG report states that:</p> <p><i>The EAG notes that as the company has calculated non-CV mortality as the difference between all-cause mortality and CV mortality, if treatment with dapagliflozin does provides a benefit to CV mortality as suggested by the company's primary efficacy outcome, then as no difference was found in all-cause mortality between the trial arms over the study period this suggests dapagliflozin must have an equal worsening impact on non-CV mortality.</i></p>	<p>This statement is incorrect, and therefore the Company kindly requests for the statement to be removed from the EAG report.</p>	<p>It is incorrect to conclude that dapagliflozin had no effect on all-cause mortality. The EAG assumption is that a non-statistically significant difference is equivalent to a hazard ratio (HR) of 1. The HR for all-cause mortality in the DELIVER trial between dapagliflozin and placebo was 0.94. This indicates that dapagliflozin reduces all-cause mortality versus placebo.</p> <p>Disregarding this HR, and assuming clinical equivalence because the p-value is >0.05 is inappropriate. As previously detailed in response to Issue 1 detailed above, a p-value >0.05 does not mean that dapagliflozin and SoC are clinically equivalent, given that DELIVER was not pre-specified or powered to detect statistically significant differences in all-cause mortality.</p> <p>Based on this, the resulting assumption that dapagliflozin has an equal worsening impact on non-CV mortality is completely unfounded, and amounts to speculation. This is further highlighted by the similar numbers of non-CV deaths observed for patients receiving dapagliflozin (266; 497 all-</p>	<p>This is not a factual inaccuracy.</p> <p>The HR of 0.94 omits the 95% confidence interval and p-value which suggests this finding may be due to chance.</p> <p>The EAG has not included statements like "clinical equivalence" within the EAG report. However, the EAG considers that the company should provide robust evidence in support of a claim of a reduction in all-cause mortality attributable to treatment with dapagliflozin.</p> <p>The EAG does not consider that the company has presented sufficient evidence to prove an all-cause mortality benefit. In addition, the EAG's clinical experts did not expect treatment with dapagliflozin to have an impact on all-cause mortality.</p>

		<p>cause deaths minus 231 CV deaths) and placebo (265; 526 CV deaths minus 261 non-CV deaths).</p> <p>Given the above, the Company kindly requests the EAG to remove this statement from their report.</p>	
--	--	--	--

Issue 5 Comments in Key Issue #1: Estimation of KCCQ-TSS transition probabilities in the economic model

Description of problem	Description of proposed amendment	Justification for amendment	EAG response
<p>On Page 16, the EAG report Key Issue 1 states that:</p> <p><i>If the company confirms that LOCF was used for patients missing an assessment at any of these time-points in producing transition probabilities, the EAG would like to see an analysis without imputation to determine the impact of the LOCF assumption on the observed data</i></p> <p><i>The extent of any impact on the ICER is unclear but using LOCF for patients with missing data at scheduled assessments (if it is confirmed that this is what has been done) has</i></p>	<p>The Company kindly requests that these statements are removed from the EAG report.</p>	<p>The Company can confirm that imputation was not used for missing data, and the assumption of last observed carried forward (LOCF) was not used to account for missing data at scheduled assessments.</p> <p>Given the above, the EAG's Key Issue #1 is redundant and could result in potentially misleading interpretation of the DELIVER trial. The Company kindly requests that this should be removed from the report.</p>	<p>Thank you for providing this additional information to confirm that LOCF was not used for data missing at scheduled KCCQ-TSS assessments when calculating transition probabilities.</p> <p>The EAG consider Key Issue 1 to be resolved given this new information. The report has been updated to reflect this.</p>

Description of problem	Description of proposed amendment	Justification for amendment	EAG response
<p><i>the potential to favour the more effective treatment, as earlier benefits would be maintained despite not knowing their current KCCQ-TSS status. This has the potential to reduce the ICER.</i></p>			

Issue 6 Interpretation of CV mortality extrapolations

Description of problem	Description of proposed amendment	Justification for amendment	EAG response
<p>Issue 4: Underestimations of CV mortality in the economic model</p> <p><u>Furthermore</u></p> <p>On Page 19, the EAG report states</p> <p><i>The company's base case Weibull extrapolations are likely to be greatly underestimating CV mortality (~30% survival at 92 years old)</i></p>	<p>The Company kindly requests that the EAG report is updated to correct the misinterpretation of CV mortality extrapolations.</p> <p><u>Furthermore</u></p> <p>The Company requests the sentence below is updated as follows:</p> <p>Page 19</p> <p><i>The company's base case Weibull extrapolations are likely to be greatly underestimating CV mortality (~30% survival of patients had not died due to CV mortality at 92 years old)</i></p>	<p>The Company believe the EAG have misinterpreted the statement presented in the CS. The EAG seem to conclude that the Weibull extrapolation predicts that at 92 years, 30% of patients remain alive. This is not the case and in fact this statement states that of the people who did die by the age of 92, 30% of people who had died at this point did not die due to CV death but died due to other cause.</p> <p>The model, using the Weibull distribution, actually predicts that at 92 years 5.3% of people who enter the model remain alive and when compared to the general population estimates, 15.5% remain alive. The Gompertz model assumes that 0% are</p>	<p>The EAG thanks the company for highlighting this factual inaccuracy, the EAG has made the requested change.</p>

Description of problem	Description of proposed amendment	Justification for amendment	EAG response
<p>On Page 87, the EAG report states</p> <p><i>However, the EAG questions the clinical plausibility of the adjusted Weibull survival model, given that for CV mortality (Figure 2) [REDACTED] of the patient cohort are still alive [REDACTED] (and would be 101.67 years old</i></p>	<p>Page 89</p> <p>The company requests for the statement to be amended as follows:</p> <p><i>However, the EAG questions the clinical plausibility of the adjusted Weibull survival model, given that for CV mortality (Figure 2) [REDACTED] of the patient cohort had not died due to CV mortality are still alive [REDACTED] (and would be 101.67 years old).</i></p>	<p>alive after 92 years which is clinically implausible.</p> <p>Therefore, the company firmly believe that the estimates of the Weibull distribution are plausible and the most appropriate to inform base case.</p> <p>The CV mortality extrapolations do not provide any estimates of overall survival. Therefore, the number of patients still alive at any given time point in the model cannot be derived from the CV mortality extrapolations.</p> <p>Given this, the EAG should amend these statements to highlight that the quoted percentages relate to the number of patients who have not died as a result of CV mortality.</p> <p>CV death survival cannot be assessed independently of other forms of mortality. These data represent only one form of mortality, therefore, the persistent survival in these extrapolations means only that there is no further CV death because other forms of death have taken over.</p> <p>The distribution results must be assessed in the context of the Cost Effectiveness Model (CEM) where such high survival is not predicted. In the CEM, non-CV (from the trial) and UK</p>	<p>This is not a factual inaccuracy. The patient cohort would be 101.67 years old after 30 years in the CEM.</p>

Description of problem	Description of proposed amendment	Justification for amendment	EAG response
<p>Section 3.2.6.7, on page 86</p> <p><i>However, these extrapolations still provided clinically implausible CV and all-cause mortality predictions.</i></p> <p>Section 3.2.6.8, on page 88</p> <p><i>Given the poor extrapolation fit may be artifact of extrapolating only part of the mortality data of the DELIVER study and the company did not provide a clinically plausible rationale for the inflection point in KM</i></p>	<p>Section 3.2.6.7, page 86</p> <p>The Company requests that this sentence is removed as it is factually inaccurate.</p> <p>Section 3.2.6.8, page 88</p> <p>The Company kindly requests that this sentence is removed.</p>	<p>life table general population mortality are applied as further competing risks.</p> <p>In addition, piecewise modelling is not appropriate as all data are included. The inflection point identified was not applicable to the treatment arm (only relevant to KCCQ-TSS health states), thus no biological explanation is relevant. The approach was determined according to NICE guidelines as described in clarification questions and the EAG did not provide an alternative to inform why deviation from the guidelines was appropriate or how guidelines were not followed.</p> <p>The displayed plots include only the trial extrapolated all-cause mortality. In the context of the CEM, a competing risks framework is applied, comparing the risk of CV, non-CV and general UK population background mortality. The Gompertz distribution does not represent the only clinically plausible distribution since the survival predicted in this framework is considerably lower and the Weibull distribution (as acknowledged in the EAG CQs) was a plausible selection.</p>	<p>This is not a factual inaccuracy.</p> <p>This sentence has been taken out of context and instead refers to the extrapolations outside of the Weibull and Gompertz, which provide clinically implausible results.</p> <p>This is not a factual inaccuracy. No change required.</p>

Description of problem	Description of proposed amendment	Justification for amendment	EAG response
<i>curves between the trial arms</i>		Extrapolations were not based on only part of the DELIVER trial data but instead included all data. No rationale was proposed of a difference in inflection between the trial arms because none was proposed. Separate models for dapagliflozin and placebo were not fit, nor was there demonstration of a violation of proportional hazards according to treatment arm. As per the Company submission, adjustment was to address evidence of lack of proportional hazards due to KCCQ-TSS-defined health states.	

Issue 7 Multiplicatively adjusted population utilities

Description of problem	Description of proposed amendment	Justification for amendment	EAG response
<p>On Page 92, the EAG report states:</p> <p><i>While the company has recalculated and rectified the issues highlighted by the EAG, they have done so using an additive approach in contrast to the multiplicative</i></p>	<p>The Company kindly requests that this sentence is rephrased to reflect the full interpretation of the NICE DSU TSD 12 recommendations.</p>	<p>NICE DSU TSD 12 also states <i>“that there is currently no consensus on the most appropriate technique and the standard methods used to adjust for comorbidities”</i>. It should be noted that the ERG incorporated a similar scenario into their preferred base case as part of TA679 where additive adjustment was used to adjust the KCCQ health state utilities from the DAPA-HF trial in line with general</p>	<p>The EAG will take into account the wording in the sentence and rephrase as necessary. While no method is explicitly recommended by NICE, section 3 of NICE DSU TSD 12, titled <i>Adjusting/combining health state utility values</i>, states <i>“Of the other methods compared [the additive, multiplicative and minimum methods], the multiplicative appears to be the most accurate overall”</i> substantiates a</p>

Description of problem	Description of proposed amendment	Justification for amendment	EAG response
<p><i>recommended in NICE DSU TSD 12.⁶⁶</i></p>		<p>population utility, and no concerns were raised.</p> <p>It is factually inaccurate for the EAG report to imply that the use of additive adjustment to health state utilities to account for comorbidities is incorrect.</p> <p>The Company acknowledges the uncertainty surrounding the most appropriate methods for utility adjustments, but notes that it is important for the EAG report to reflect the uncertainty in the published literature, and provide a full summary of the recommendations from NICE DSU TSD 12.</p> <p>The EAG have also cross-referenced many of the other assumptions in their report versus TA679; it is therefore also considered appropriate that the similar scenario in TA679, where the ERG accepted additive methods for utility adjustments, is also referenced here.</p>	<p>preference for the multiplicative method to be used.</p>

Issue 8 Incorrect reporting of data – revised Company base case results

Description of problem	Description of proposed amendment	Justification for amendment	EAG response
<p>On Page 70, the EAG report states:</p> <p><i>Table 18 below presents the incremental cost-effectiveness results of the company's updated (post-clarification) base case results</i></p> <p>The table included presents the original Company base case PSA results and not the updated results following clarification questions</p>	<p>The Company requests that the contents of Table 18 are updated with the contents of Table 36 (the revised base case PSA ICER is £7,276.)</p>	<p>The originally submitted Company base case PSA results have been presented here instead of the revised Company base case PSA results presented within the Clarification Question response document. The correct revised base case PSA results are reported in Table 36 of the EAG report and should be replicated in Table 18.</p>	<p>The EAG thanks the company for highlighting this factual inaccuracy and has updated Table 18 to reflect Table 36.</p>

Issue 9 Incorrect reporting of KCCQ data collection

Description of problem	Description of proposed amendment	Justification for amendment	EAG response
<p>Section 3.2.6.2, page 79 <i>...between scheduled KCCQ-TSS assessments (which took place at 1, 4 and 8 months) ...</i></p> <p><i>Given that KCCQ-TSS measurements were only scheduled to be taken at</i></p>	<p>The Company kindly requests that the EAG reword the sentences to as follows:</p> <p>Section 3.2.6.2, page 79 <i>...between scheduled KCCQ-TSS assessments (which took</i></p>	<p>Trial protocol describes KCCQ data collection at 1, 4, 8 months and a final visit (study closure or premature discontinuation). Data were therefore available and used after 8 months of follow-up, in line with observations of other model inputs for HF events and survival, for example.</p>	<p>The EAG thanks the company for highlighting this factual inaccuracy. The EAG report has been amended as appropriate throughout.</p> <p>The sentence highlighted by the company on page 80 of the report has been removed.</p>

Description of problem	Description of proposed amendment	Justification for amendment	EAG response
<p>three time-points (1, 4 and 8 months) in the DELIVER trial.</p> <p>Section 3.2.6.2, page 80</p> <p>Furthermore, the KCCQ-TSS transitions used to inform the analysis were based on 8-months of follow-up, which is relatively short compared to the lifetime time horizon of the model and the duration of follow-up used to inform other model inputs (e.g., EQ-5D data).</p>	<p>place at 1, 4, 8 months and final visit ...</p> <p>Given that KCCQ-TSS measurements were scheduled to be taken at time-points of 1, 4, 8 months and at the final visit in the DELIVER trial.</p> <p>The Company requests the EAG remove the sentence as KCCQ-TSS transitions were based on all data to the end of the trial, in line with the duration of follow-up data used to inform other model inputs.</p>		

Issue 10 Non-evidence based assumption on treatment setting

Description of problem	Description of proposed amendment	Justification for amendment	EAG response
<p>Section 1.1 page 26</p> <p>There is some concern about prescribing in primary care based on historical diagnoses without input from a HF specialist.</p>	<p>The Company kindly requests that the sentence is removed.</p>	<p>The statement is not evidence based and as result there is no evidence to suggest why such a concern should exist and including it has the potential to mislead. SGLT2 inhibitors are not more unsafe than a loop or thiazide diuretic or an ACE inhibitor or beta-blocker.</p>	<p>The EAG has amended this statement to indicate that it is based on discussions with the EAG's clinical experts.</p>

Issue 11 Incorrect interpretation of inclusion and exclusion criteria

Description of problem	Description of proposed amendment	Justification for amendment	EAG response
<p>Section 3.2.6.6, page 83</p> <p><i>Dapagliflozin has been approved by NICE for use in patients with T2DM (TA288, TA390 and TA418) and so it is possible that these patients would already be receiving treatment</i></p>	<p>The Company kindly requests that the sentence is removed.</p>	<p>As per the trial exclusion criteria for DELIVER, participants could not be taking any SGLT2i within the 4 weeks prior to randomisation, therefore the prior approval for dapagliflozin in T2DM does not have bearing on current trial results. Moreover, the DELIVER trial did not take place in any UK centres, therefore NICE technology appraisals do not apply.</p>	<p>The EAG is aware of the exclusion criteria regarding SGLT2 inhibitors in the DELIVER trial. The EAG mention this in the context of existing NICE guidance in the UK, highlighting that it is possible that some patients with HFmrEF or HFpEF in the UK are already eligible for dapagliflozin due to having T2DM. The EAG are not suggesting that patients in the trial may already have been using dapagliflozin.</p> <p>This has been amended in the EAG report to avoid confusion.</p>

Issue 12 Misleading wording in relation to all-cause mortality extrapolations

Description of problem	Description of proposed amendment	Justification for amendment	EAG response
<p>Section 3.2.6.8, page 87</p> <p><i>Likewise, the probability of survival after 30 years for all-cause mortality of the adjusted Weibull extrapolation is also [REDACTED].</i></p>	<p>Section 3.2.6.8, page 87</p> <p>The Company requests that the sentence is revised to: <i>The probability of survival after 30 years for all-cause mortality of the adjusted Weibull extrapolation is also [REDACTED].</i></p>	<p>The statement is true but the wording in connection with the preceding sentence implies a lack of clinical face validity. Survival from all-cause mortality at ~100 years in HFpEF patients is not impossible (survival above zero) given the range of ages in patients enrolled in the trial. Further, as noted above, the distribution should be considered in the context of the competing risk framework of the CEM, not solely in the statistical diagnostics informing model functions.</p>	<p>This is not a factual inaccuracy. No change required.</p>

Issue 13 Incorrect reporting of data – summary of KCCQ-TSS missing data

Description of problem	Description of proposed amendment	Justification for amendment	EAG response
<p>On Page 46, the EAG report states:</p> <p><i>At 8 months, KCCQ-TSS missing data (of those with data available at baseline) was similar between the two treatment groups but [REDACTED] missing due to death and, of those that were alive at 8 months, [REDACTED] with missing due to other reasons</i></p> <p>On Page 48, the EAG report states:</p>	<p>The Company requests that the data points and confidential markups are updated to:</p> <p>Page 46</p> <p><i>At 8 months, KCCQ-TSS missing data (of those with data available at baseline) was similar between the two treatment groups but [REDACTED] missing due to death and, of those that were alive at 8 months, [REDACTED] with missing due to other reasons</i></p>	<p>The data presented do not match the data in Table 14.2.4.2 of the CSR (Page 537 of Section 14).</p> <p>Please could the EAG correct these data, or provide further clarification where</p>	<p>The EAG notes that in the company's response to clarification question A8b, Table 14.4.2.3 in the CSR was highlighted as the relevant table for KCCQ data, as this contains values for the overall population as well, whereas Table</p>

Description of problem	Description of proposed amendment	Justification for amendment	EAG response
<p>For KCCQ-TSS outcomes, missing data for those alive at 8 months was [REDACTED] in the dapagliflozin and placebo groups, respectively ([REDACTED] died before 8 months).</p>	<p>Page 48</p> <p>For KCCQ-TSS outcomes, missing data for those alive at 8 months was [REDACTED] in the dapagliflozin and placebo groups, respectively ([REDACTED] with baseline KCCQ-TSS data died before 8 months).</p>	<p>these data have been derived from.</p> <p>As per comments below, these data should be marked as AIC, rather than CIC.</p>	<p>14.2.4.2 contains data specifically for the pre-pandemic population which was not the focus of the company submission.</p> <p>On reviewing the data again, the EAG still considers the values in Table 14.4.2.3 to be the correct values for the submission.</p> <p>Confidential marking changes have been made as requested.</p>

Issue 14 Incorrect reporting of data – summary of EQ-5D data

Description of problem	Description of proposed amendment	Justification for amendment	EAG response
<p>On Page 54, the EAG report states:</p> <p><i>The CSR indicates that for the EQ-5D-5L visual analogue scale, mean [standard deviation] baseline values were [REDACTED] between arms</i></p>	<p>The Company requests that the data points and confidential markups are updated to:</p> <p><i>The CSR indicates that for the EQ-5D-5L visual analogue scale, mean [standard deviation] baseline values were [REDACTED] between arms</i></p>	<p>The value of [REDACTED] does not match the data in Table 14.2.7.3 of the CSR (Page 571 of Section 14). Please could the EAG correct this data point.</p> <p>As per comments below, these data should be marked as AIC, rather than CIC.</p>	<p>The EAG thanks the company for highlighting this factual inaccuracy, the EAG has corrected the value in the report. Confidential marking has also been changed as requested.</p>

Description of problem	Description of proposed amendment	Justification for amendment	EAG response
([REDACTED], n= [REDACTED] vs n= [REDACTED] in dapagliflozin and placebo arms, respectively)	([REDACTED], n= [REDACTED] vs [REDACTED] in dapagliflozin and placebo arms, respectively)		

Issue 15 Incorrect reporting of data – discontinuation data

Description of problem	Description of proposed amendment	Justification for amendment	EAG response
<p>On Page 54, the EAG report states:</p> <p><i>Over the median trial follow-up of [REDACTED], premature permanent discontinuation of treatment occurred in [REDACTED] and [REDACTED] ([REDACTED]) patients in dapagliflozin and placebo groups, respectively</i></p>	<p>The Company requests that the data points are updated to:</p> <p><i>Over the median trial follow-up of [REDACTED], premature permanent discontinuation of treatment occurred in [REDACTED] and [REDACTED] ([REDACTED]) patients in dapagliflozin and placebo groups, respectively</i></p>	<p>The proportion of patients with premature permanent discontinuation of treatment in the placebo group was [REDACTED] not [REDACTED]. Please could the EAG correct this data point.</p>	<p>The EAG thanks the company for highlighting this factual inaccuracy. The EAG has corrected this in the report.</p>

Issue 16 Confidentiality highlighting corrections

Location of incorrect marking	Description of incorrect marking	Amended marking	EAG response
Throughout: Page 40, Page 45, Page 46, Pages 48-49, Pages 53-55, Pages 64-65, Pages 67-69, Page 89, Pages 125-126	Any data extracted from the Company CSR which is marked as Commercial in Confidence in the EAG Report.	Any data extracted from the Company CSR only need to be marked as AIC, not CIC.	The EAG thanks the company for highlighting this and has made this change for any data taken from the CSR.
Page 25	The EAG report states <i>Figure 13 of the CS, and [REDACTED], [REDACTED] and [REDACTED] in the clinical study report [CSR] when split based on baseline estimated glomerular filtration rate (<60 vs ≥60 ml/min/1.73m²) that a difference between subgroups was present.</i>	These data do not need to be marked as CIC: <i>Figure 13 of the CS, and HF events, CV mortality and all-cause mortality reported individually in the clinical study report [CSR] when split based on baseline estimated glomerular filtration rate (<60 vs ≥60 ml/min/1.73m²) that a difference between subgroups was present.</i>	The EAG thanks the company for highlighting this and has made the requested change.
Page 36	The EAG report states: <i>This group is defined as those who have previously had an LVEF of ≤40% that has since improved to be >40% and comprised [REDACTED] of the overall trial population in DELIVER.</i>	Please note that this was erroneously marked as AIC in the Company Submission Document B. The revised marking is below: <i>This group is defined as those who have previously had an LVEF of ≤40% that has since improved to be >40% and</i>	The EAG thanks the company for highlighting this and has made the requested change.

Location of incorrect marking	Description of incorrect marking	Amended marking	EAG response
		<i>comprised ~18% of the overall trial population in DELIVER.</i>	
Page 53	The EAG report states: <i>For all randomised patients with data available, when compared with placebo using a [REDACTED]</i>	The term repeated measured mixed-effects model does not need to be marked as CIC here.	The EAG thanks the company for highlighting this and has made the requested change.
Page 57	The EAG report states: [REDACTED] AE ^f	“Any stroke” is not marked as AIC in the Company Submission Document B and can therefore be unmarked here. The revised marking is below: <i>Any stroke AE^f</i>	The EAG thanks the company for highlighting this and has made the requested change.
Page 60	The EAG report states: [REDACTED]	These data (the HR and associated 95% confidence interval and p-value for the composite primary outcome in patients with prior LVEF ≥40%) are published and therefore do not need to be marked as AIC. The revised marking is below: <i>0.74 (0.56 to 0.97; p=0.031)</i>	The EAG thanks the company for highlighting this and has made the requested change.
Page 92	The EAG report states: “the model predicted undiscounted life years of [REDACTED] for SoC”	The undiscounted life years do not need to be marked as confidential.	The EAG thanks the company for highlighting this and has made the requested change.

Location of incorrect marking	Description of incorrect marking	Amended marking	EAG response						
Page 93	<p>The EAG reports utility values from TA679:</p> <table border="1" data-bbox="524 357 1081 612"> <thead> <tr> <th data-bbox="524 357 1081 405">TA679</th> </tr> </thead> <tbody> <tr> <td data-bbox="524 405 1081 453">■</td> </tr> <tr> <td data-bbox="524 453 1081 501">■</td> </tr> <tr> <td data-bbox="524 501 1081 549">■</td> </tr> <tr> <td data-bbox="524 549 1081 596">■</td> </tr> <tr> <td data-bbox="524 596 1081 644"></td> </tr> </tbody> </table>	TA679	■	■	■	■		These are publicly available and do not need to be marked as confidential.	The EAG thanks the company for highlighting this and has made the requested change.
TA679									
■									
■									
■									
■									



Dapagliflozin for treating chronic heart failure with preserved or mildly reduced ejection fraction [ID1648]

Addendum to the EAG report

January 2023

Source of funding

This report was commissioned by the NIHR Evidence Synthesis Programme as project number 135673.

1 Introduction

This document provides the additional scenarios, calculations and graphs requested by NICE resulting from the Evidence Assessment Group's (EAG's) critique of the company's submission.

2 Additional economic analysis undertaken by the EAG

The following scenarios, calculations and graphs have been requested by NICE following the critique.

Scenarios:

- Assuming a cardiovascular (CV) treatment effect and no all-cause mortality (ACM) treatment effect;
- Assuming a CV and ACM treatment effect;
- Assuming no CV or ACM treatment effect;
- Excluding costs of non-CV deaths when survival benefits are assumed.

Calculations:

- The net health benefit (NHB) using £20,000 and £30,000 willingness to pay thresholds.

Graphs:

- CV and ACM Kaplan-Meier (KM) curves for dapagliflozin and SoC from the DELIVER trial.

The scenarios requested by NICE build on from the preferred EAG's assumptions as outlined in Table 39 of the EAG report. These assumptions are summarised below:

1. Age-adjusted utilities;
2. Multiplicative population adjusted utilities;
3. Removal of amputation from adverse events;
4. Non-elective inpatient costs taken from NHS Reference costs 19/20 and inflated to the 20/21 cost year;
5. Hospitalisation due to heart failure (HHF) disutility applied for 2.75 months;
6. 6 annual GP visits per year;

7. Use of cost code associated with shorter HHF length of stay;
8. Removal of dapagliflozin treatment effects from UHFV event calculations;
9. Removal of dapagliflozin treatment effects from CV and ACM survival curve calculations.

For this addendum, the EAG conducted the requested scenarios while incorporating the EAG's preferred assumptions. Exceptions to this are the scenarios which require the removal of bullet point 9 from the EAGs preferred assumptions. The NICE requested scenarios and results are highlighted in Table 1 below.

Table 1. NICE requested scenarios and results.

Scenario	Incremental costs (£)	Incremental LYG	Incremental QALYs	ICER (£/QALY)
EAG preferred assumptions - no CV or ACM treatment effect in survival calculations	£1,974	0.068	0.086	£22,972
1. No dapagliflozin treatment effect in CV or ACM survival calculations, exclusion of non-CV death costs.	£1,978	0.068	0.086	£23,016
2. Inclusion of dapagliflozin in CV and ACM treatment effect calculations	£2,179	0.370	0.225	£9,694
3. Inclusion of the dapagliflozin treatment effect in CV and ACM survival calculations with no cost associated with non-CV deaths	£2,114	0.370	0.225	£9,407
4. Inclusion of the dapagliflozin treatment effect in CV survival calculations and the removal of the dapagliflozin treatment effects from ACM survival calculations	£2,075	0.068	0.086	£24,137
5. Inclusion of the dapagliflozin treatment effect in CV survival calculations, the removal of the dapagliflozin treatment effect from ACM survival calculations and no cost associated with non-CV deaths.	£1,919	0.068	0.086	£22,321

Abbreviations: ACM, all-cause mortality; CV, cardiovascular, EAG, evidence assessment group.

Comparing the EAG's preferred assumptions to scenario 1, when non-CV death costs are removed from cost calculations, the ICER slightly increases as the incremental costs increase. This increase stems from a slightly higher non-CV death cost associated with SoC than dapagliflozin (£2,080 and £2,076, respectively).

Comparing the EAG's preferred ICER to scenario 2, applying a CV and ACM treatment effect leads to a large increase in incremental QALYs and a small increase in incremental costs leading to an overall decrease in the ICER. As the average total costs associated with non-CV mortality is greater in the dapagliflozin treatment arm than SoC (£2,144 and £2,079, respectively), the removal of costs associated with non-CV deaths in scenario 3 reduces the incremental costs by the difference in non-CV deaths leading to a decrease in the ICER.

Assuming a dapagliflozin treatment effect in CV calculations as in scenario 4 leads to a very small increase in incremental QALYs (from 0.08594 to 0.08598) and a small increase in costs which overall leads to an increase in the ICER compared to the EAG's ICER. The increase in costs is caused by the decrease in CV mortality and the reciprocal increase in non-CV mortality which has a higher attributed cost in the dapagliflozin treatment arm. On further investigation into why assuming a CV treatment effect leads to such a small incremental increase in QALYs, the model reflects that the CV treatment effect leads to [REDACTED] over the duration of the economic model with no real overall gain in life years as ACM remains unchanged. Therefore, the partial gains in incremental QALYs generated through decreased probability of CV mortality are almost negligible and are reduced further by the partial increase in adverse and HF events stemming from those benefiting from the decreased probability of CV mortality. The decrease in incremental costs when no non-CV mortality cost is assumed is caused via the same mechanism as described between scenarios 2 and 3; that is, as total non-CV costs in the dapagliflozin trial arm are greater than the SoC arm the removal of these costs leads to a reduction in the incremental difference, reducing the ICER.

In addition to the requested scenarios, NICE asked for the calculation of the net health benefit (NHB) associated with the EAG's preferred assumptions using a £20,000 and £30,000 willingness to pay threshold. With the EAG's assumptions, the NHB is -0.013 and 0.02, when using a willingness to pay threshold of £20,000 and £30,000, respectively.

3 Additional figures requested by NICE

Figure 1. Observed cardiovascular mortality data in the DELIVER trial



Figure 2. Observed all-cause mortality data in the DELIVER trial

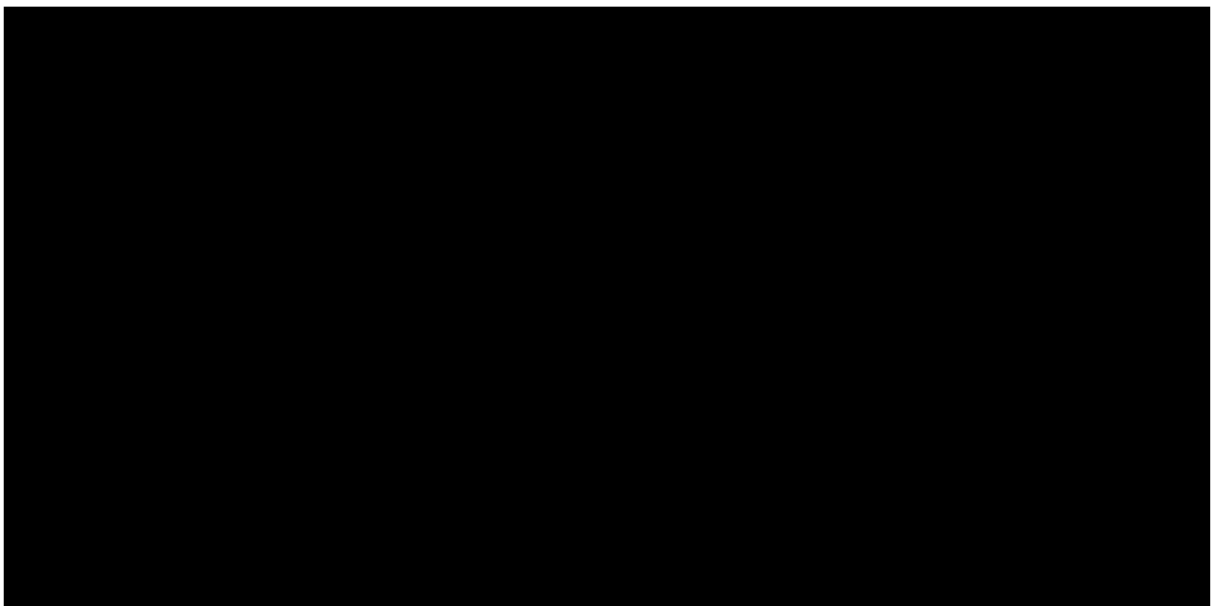
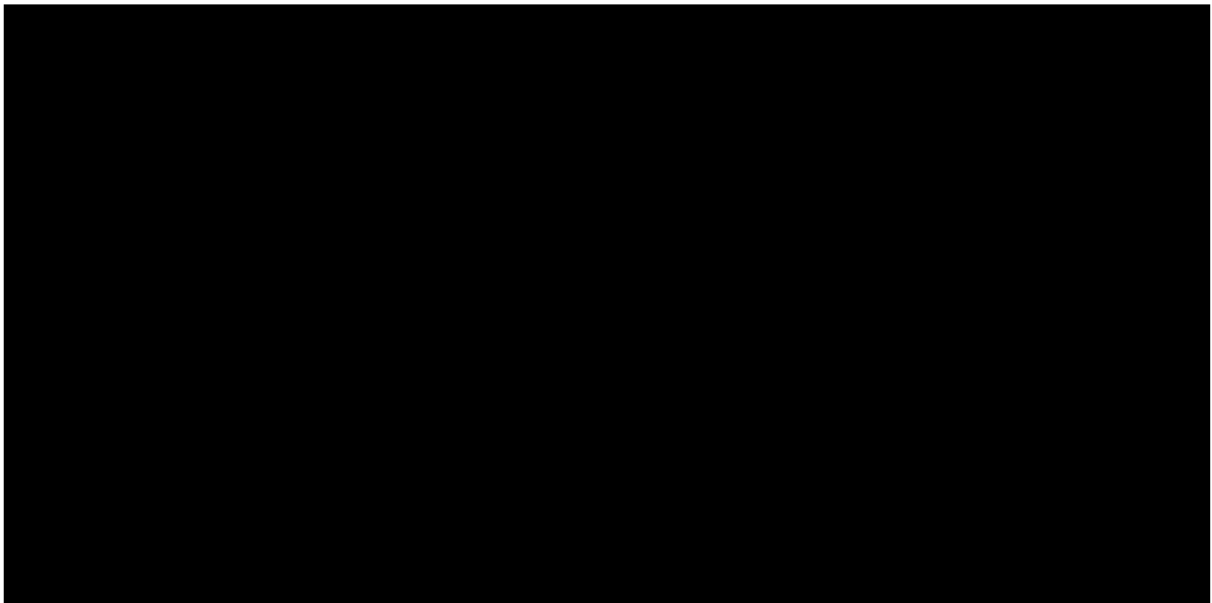

Figure 3. Observed cardiovascular mortality data in the DELIVER trial (zoomed in)



Figure 4. Observed all-cause mortality data in the DELIVER trial (zoomed in)



Scenarios assessing direct and indirect treatment effect of dapagliflozin on CV and all-cause deaths:

The table below outlines the ICER outcomes depending on dapagliflozin treatment effect assumptions. The scenarios include the EAGs preferred assumptions:

Assumptions			Incremental costs	Incremental LYG	Incremental QALYs	ICER
CV death: Direct and indirect effect	All-cause deaths: Direct and indirect effect	Non-CV death cost included	£ 2,179	0.37	0.225	£9,694
CV death: Direct and indirect effect	All-cause deaths: Direct and indirect effect	Non-CV death cost not included	£ 2,114	0.37	0.225	£9,407
CV death: Direct and indirect effect	All-cause deaths: Indirect effect only	Non-CV death cost included	£2,075	0.068	0.086	£24,137
CV death: Direct and indirect effect	All-cause deaths: Indirect effect only	Non-CV death cost not included	£1,919	0.068	0.086	£22,321
CV death: Indirect effect only	All-cause deaths: Indirect effect only	Non-CV death cost included	£ 1,974	0.068	0.086	£22,972
CV death: Indirect effect only	All-cause deaths: Indirect effect only	Non-CV death cost not included	£ 1,978	0.068	0.086	£23,016
CV death: No effect*	All-cause deaths: No effect*	Non-CV death cost included	£ 1,542	0	0.043	£35,636
CV death: No effect*	All-cause deaths: No effect*	Non-CV death cost not included	£ 1,542	0	0.043	£35,636

*The removal of the indirect treatment effect reflects there is no survival benefit from KCCQ health state occupancy in addition to the removal of the indirect treatment effect.